

Berkel Gravity Feed Slicers

909FS, 919FS



Berkel introduces the new Model 909FS Manual and Model 919FS Automatic gravity feed slicers.

By reducing costs through "value engineering" but without compromising Berkel's renowned slicer performance, these models are offered at *highly* competitive prices.

Designed to meet most all food service slicer needs, plus many other applications. They feature our "top of the line" hollow ground, hardened and polished stainless steel knife, our built-in dual action sharpener and a powerful motor.

And should service ever be necessary, the 909FS and 919FS, like all Berkel products, are backed by our nation-wide service network.

- Stainless steel tapered permanent Knife Guard covers non-slicing portion of knife even when the sharpener and center plate are removed.
- Hardened, hollow ground and polished stainless steel knife.
- Built-in, high precision, dual action sharpener — for a lasting, razor sharp edge.
- Model 919FS automatically slices 50 slices per minute.
- Easy to clean — disassembles quickly without tools.

Berkel

FEATURES

- Tapered, anodized aluminum permanent knife guard.
- 12 1/2" hollow ground stainless steel knife.
- Model 919FS automatically slices 50 slices per minute.
- Full length stroke during automatic operation.
- Positive action toggle switch and power light.
- Easy glide product table.
- Anodized aluminum meat pusher.
- New easy access, dual action top mounted sharpener.
- All food receiving areas feature rounded corners and joints to prevent bacteria growth and promote easy clean-up.
- Fast, easy clean-up, disassembly without tools — most product contact parts are submersible or dishwasher safe.

SPECIFICATIONS

● Operation:	909FS — Manual Gravity Feed. 919FS — 1 Speed Automatic or Manual Gravity Feed.
● Cutting Capacity:	Up to 11" (280 mm) wide, 6" (152 mm) high or 8" (203 mm) diameter.
● Slice Thickness:	Up to 27/32" (21 mm).
● Knife:	12 1/2" (318 mm) diameter, hollow ground, hardened, and polished stainless steel.
● Knife Sharpener:	Built-in, two stone, dual action system.
● Slicing Speed:	919FS — 50 slices per minute.
● Motor:	1/2 H.P., 115 volt, 60 cycle, single phase, 5.5 amp, A.C., thermally protected.
● Finish:	Stainless Steel and Burnished Aluminum.
● Weight:	909FS — Net: 90 lb (41 kg) Shipping: 129 lb (55 kg) 919FS — Net: 114 lb (52 kg) Shipping: 152 lb (69 kg)

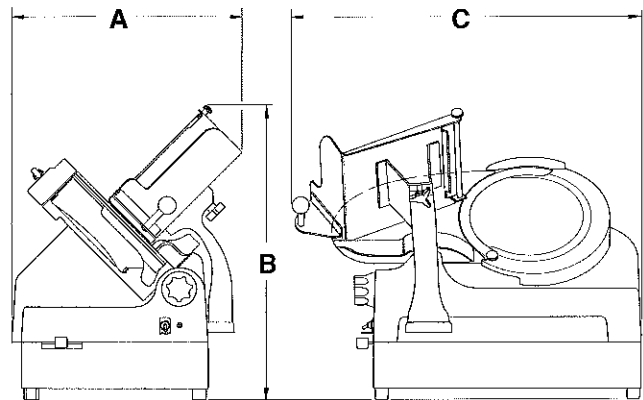

Model 909FS

A:	20" (508 mm)
B:	21" (533 mm)
C:	29" (737 mm)

Model 919FS

A:	20" (508 mm)
B:	24" (610 mm)*
C:	29" (737 mm)

* Add 3" (76 mm) for NSF legs.



As we continually strive to improve our products, specifications are necessarily subject to change without notice.

Berkel Incorporated
One Berkel Drive
LaPorte, IN 46350
Telephone (219) 326-7000
FAX (219) 324-2928



In Canada:
Berkel Products Co., Ltd.
Toronto
Telephone (905) 625-4160
FAX (905) 625-3166