



**HV-100G and ZEPHAIRE-G PLUS**  
Hydrovection Stacked on a Full-Size Gas Convection Oven



*HV-100G Approvals*



*Zephaire-G Plus Approvals*



Project \_\_\_\_\_

Item No. \_\_\_\_\_

Quantity \_\_\_\_\_

*Requires Blodgett stacking kit #52896.*

This model consists of a standard HV-100G stacked on a standard Zephaire-G Plus. For more information on each oven refer to the the HV-100G and Zephaire -G Plus specifications sheets.

**SHORT FORM SPECIFICATIONS** Provide Blodgett model HV-100G Hydrovection stacked on a model ZEPHAIRE G PLUS full-size gas convection oven.

**HV-100G Hydrovection** - Shall have fully welded 316 stainless steel liner. Liner to be covered top and bottom. Unit shall accept five 18" x 26" standard full-size bake pans. Doors shall be triple mounted, stainless steel with dual pane thermal glass windows, single tubular handle and simultaneous operation. Unit shall be heated by 70,000 BTU gas burner. Air in baking chamber distributed by single inlet blower wheel powered by a four speed, auto-reversing, 1/2 HP motor with thermal overload protection. Each chamber shall be fitted with bright halogen lamps, and five standard stainless steel removable racks. Unit shall have manual control with hydro low and hydro high moisture control, hot air and cool down modes. Breaker shut off switch on front panel for easy service. 1 year parts and 1 year labor warranty.

**Zephaire G Plus** - Shall have porcelainized steel liner and shall accept five 18" x 26" standard full-size bake pans in left-to-right or front-to-back positions. Doors shall have dual pane thermal glass windows with single porcelain handle and simultaneous operation. Unit shall be gas heated with electronic spark ignition and shall cook by means of a dual-flow system combining direct and indirect heat. Air in baking chamber distributed by dual inlet blower wheel powered by a two speed, 1/3 HP motor with thermal Overload protection. Each chamber shall be fitted with five chrome-plated removable racks. Control panel shall be recessed with Cook/Cool Down mode selector, solid state manual infinite thermostat (200 - 500°F), and 60-minute timer. 1 year parts and 1 year labor, three year limited door warranty.

**SHIPPING INFORMATION:**

**Approximate Weight:**

HV-100G 520 lbs. (236 kg)  
Zephaire G Plus 617 lbs. (280 kg)

**Crate size:**

Each section 37-1/2" (952mm) x 43-1/2" (1105mm) x 52" (1321mm)

**HV-100G STACKED ON A ZEPHAIRE-G PLUS**

**BLODGETT OVEN COMPANY**

www.blodgett.com

44 Lakeside Avenue, Burlington, VT 05401 • Phone: (802) 658-6600 • Fax: (802) 864-0183



# HV-100G STACKED ON A ZEPHAIRE-G PLUS

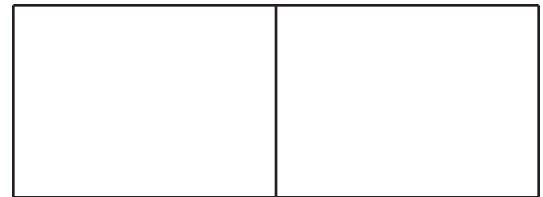

APPROVAL/STAMP

DIMENSIONS ARE IN INCHES (MM)

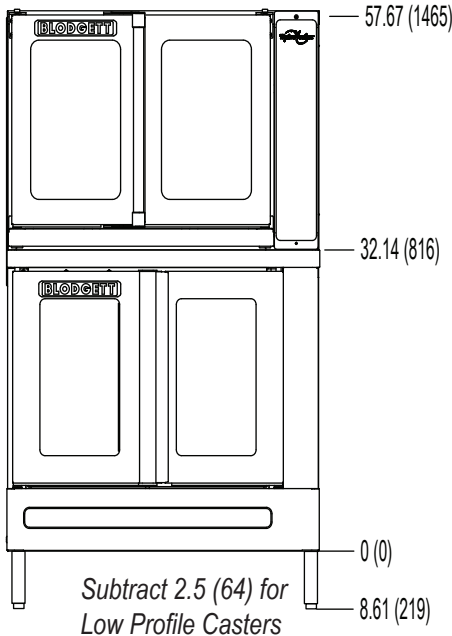

FRONT VIEW

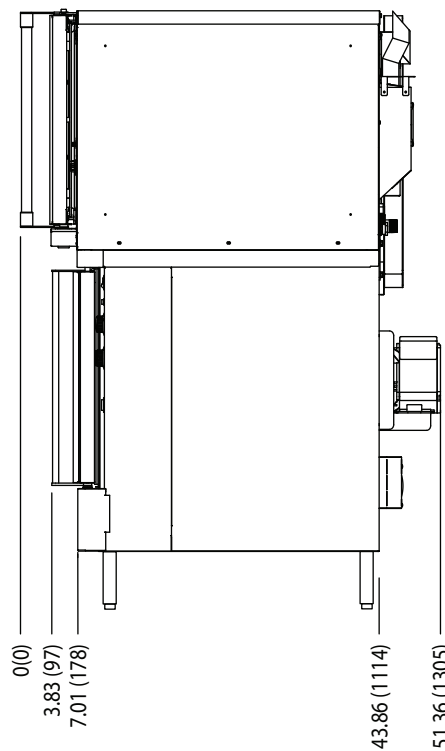

SIDE VIEW

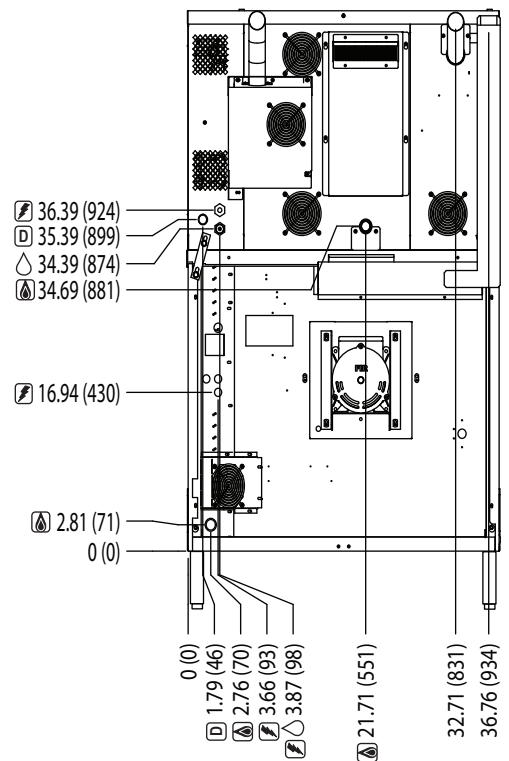

REAR VIEW

**PRODUCT CLEARANCE:**

6" (152mm) from combustible and non-combustible construction

**MAXIMUM INPUT:**

HV-100G 60,000 BTU/hr  
Zephaire G Plus 60,000 BTU/hr

**GAS SUPPLY:**

**HV-100G**

3/4" NPT

Inlet Pressure:

Natural 7.0" W.C. static to unit  
Propane 14.0" W.C. static to unit

**Zephaire-G Plus**

3/4" IPS connection at rear of oven

Manifold Pressure:

- Natural – 3.5" W.C.
- Propane – 10" W.C.

Inlet Pressure:

- Natural – 7.0" W.C. min. – 10.5" W.C. max.
- Propane – 10.5" W.C. min. – 13.0" W.C. max.

**POWER SUPPLY:**

**HV-100G**

Standard 120VAC, 20 amp, Nema 5-20R dedicated receptacle  
Option 208/240VAC, 15 amp, Nema 6-15 dedicated receptacle  
Export Export voltages available on request

Blodgett recommends a Pass & Seymour, model 2095, GFCI for this oven model due to the use of a variable frequency drive.

**Zephaire-G Plus**

115 VAC, 1 phase, 6 Amp, 60 Hz., 2-wire with ground,  
1/3 H.P., 2 speed motor, 1140 and 1725 RPM  
230, 220/240VAC, 1 phase, 3 Amp, 50 Hz., 2-wire with ground, 1/3 H.P., 1 speed motor, 1425 RPM  
6' (1.8m) electric cord set furnished on 115 VAC ovens only.

**WATER SUPPLY (HV-100G only):**

TDS: < 100 ppm Hardness: 80-120 ppm pH: 7.0 - 8.0  
Chlorides: < 30 ppm Chlorine: 0 ppm 30(min)-50(max) PSI  
Avg Drain Temp 140°F (60°C)  
Water Consumption 2.5 - 3.0 GPH  
Appliance is to be installed with backflow protection in accordance with Federal, State or Local codes.

**NOTE:** The company reserves the right to make substitutions of components without prior notice

**BLODGETT OVEN COMPANY**

www.blodgett.com 44 Lakeside Avenue, Burlington, VT 05401 • Phone: (802) 658-6600 • Fax: (802) 864-0183