



MODEL HV-100G Full-Size Gas Oven



HV-100G double shown

Project _____

Item No. _____

Quantity _____

HV-100G

Standard depth baking compartment - accepts five 18" x 26" standard full-size baking pans in left-to-right positions.

All data is shown per oven section, unless otherwise indicated.

Refer to operator manual specification chart for listed model names.

EXTERIOR CONSTRUCTION

- Fully welded angle-iron frame
- Stainless steel front, top and sides
- Simultaneous split door operation with catch-latch system
- Triple mounted door design with turnbuckle assembly
- Dual pane tempered viewing window with hinged inner glass for easy cleaning
- Modular slide out front control panel with major components for ease of service
- Retractable hand shower for ease of cleaning

INTERIOR CONSTRUCTION

- 316 stainless steel coved corner liner for easy cleaning
- Five stainless steel racks and ten rack positions
- Two halogen interior lights for superior visibility
- Drain in oven cavity
- Hinged air pressure panel for easy cleaning
- Up to 2.5" of mineral board insulation for greater heat retention

OPERATION

- Standard control with function selection for hydro low, hydro high, hot air, and cool down
- Retherm and Fry bands on control
- Three inshot burners
- Direct spark ignition
- Removeable core temperature probe
- Hydrovection cook modes provide low or high humidity
- Hot air cook mode for baking and pastries
- One touch cooking
- Four speed auto-reversing fan motor for even bake
- Cavity vent control provides ability to release steam at the push of a switch
- Thermostatically controlled quench system, Eco-Friendly

STANDARD FEATURES

- 25" (635mm) adjustable stainless steel legs (for single units)
- 8-1/2" (216mm) stainless steel legs with casters (for double sections)
- 1 year parts and 1 year labor warranty

OPTIONS AND ACCESSORIES

(AT ADDITIONAL CHARGE)

- **Legs/casters/stands:**
 - 11" (279mm) adjustable legs
 - 11" (279mm) seismic feet
 - 25" (635mm) stainless steel open stand with rack guides
- MenuSelect control can hold multi-stage programming for up to 99 products, includes Cook & Hold and core probe cooking
- Extra stainless steel oven racks
- Additional core probe
- Chicken roasting rack
- French fry pan
- Water pressure regulator
- Side heat shield



BLODGETT OVEN COMPANY

www.blodgett.com

44 Lakeside Avenue, Burlington, VT 05401

Phone: (802) 658-6600 • Fax: (802) 864-0183



MODEL HV-100G

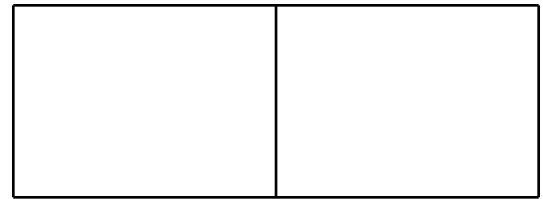

APPROVAL/STAMP

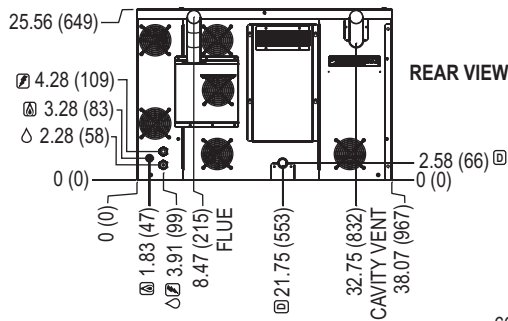
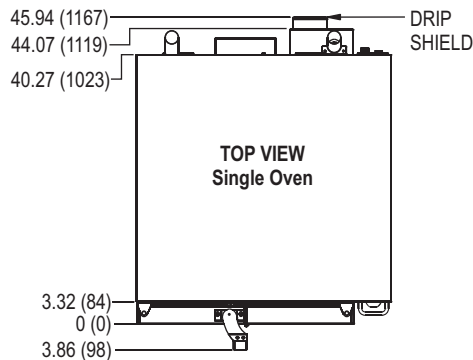

DIMENSIONS ARE IN INCHES (MM)

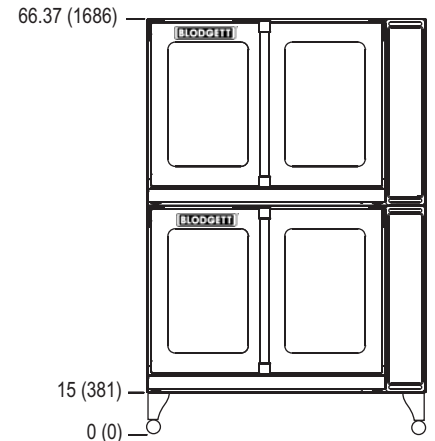
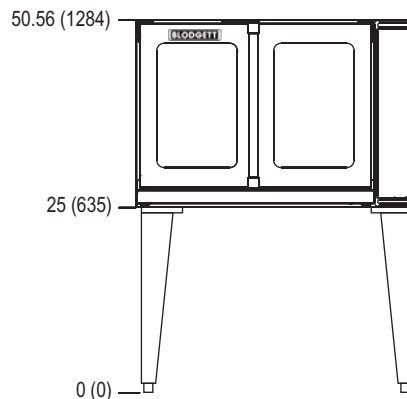
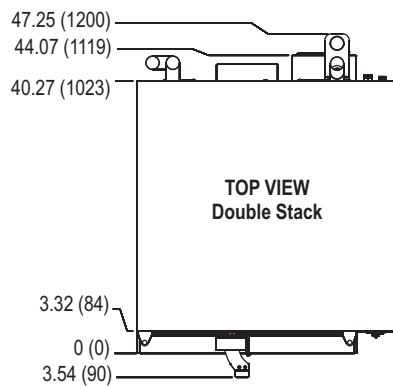

SHORT FORM SPECIFICATIONS Provide Blodgett full-size hydrovection oven model HV-100G. (single/double) compartment with fully welded angle iron frame. Each compartment shall have fully welded 316 stainless steel liner. Liner to be covered top and bottom. Unit shall accept five 18" x 26" standard full-size bake pans. Doors shall be triple mounted, stainless steel with dual pane thermal glass windows, single tubular handle and simultaneous operation. Unit shall be heated by 70,000 BTU gas burner. Air in baking chamber distributed by single inlet blower wheel powered by a four speed, auto-reversing, 1/2 HP motor with thermal overload protection. Each chamber shall be fitted with bright halogen lamps, and five standard stainless steel removable racks. Retractable hose reel mounted just below the control for easy cleanup. Unit shall have manual control with hydro low and hydro high moisture control, hot air and cool down modes. Breaker shut off switch on front panel for easy service. 1 year parts and 1 year labor warranty Provide options and accessories as indicated.

DIMENSIONS:

- Floor space** 38.07" (967mm) W x 45.9" (1166mm) D
- Interior** 29" (737mm) W x 20" (508mm) H x 23.43" (595mm) D
- Single oven on casters** Add 4-1/2" (114mm) to height
- Product clearance from combustible and non-combustible construction**
- Oven sides** 0" (0mm) Blodgett recommends 4" clearance from any heat source on the control panel side of the oven, an optional heat shield should be considered
- Oven back** 6" (152mm)

WATER & DRAIN CONNECTION (per section):

- 1" NPT drain connection 140°F (60°C) avg. drain temp.
- 3/4" NPT garden hose - cold water only
- Appliance is to be installed with backflow protection in accordance with Federal, State or Local codes.

WATER SUPPLY (per section):

- Good quality water feed is the responsibility of the owner. The use of water that is not within the following guidelines will void the warranty.
- TDS: < 100 ppm Hardness: 80-120 ppm pH: 7.0 - 8.0
- Chlorides: < 30 ppm Chlorine: 0 ppm 30(min)-50(max) PSI
- The best defense against poor water quality is a water filter system designed to meet your water quality conditions. **Filtered water is highly advised.**

Water Consumption 2.5 - 3.0 GPH

POWER SUPPLY (per section):

- Standard 120VAC, 20 amp, Nema 5-20R dedicated receptacle
- Option 208/240VAC, 15 amp, Nema 6-15 dedicated receptacle
- Export Export voltages available on request
- Blodgett recommends a Pass & Seymour, model 2095, GFCI for this oven model due to the use of a variable frequency drive.

GAS SUPPLY (per section):

- 3/4" NPT
- Inlet Pressure:**
- Natural 7.0" W.C. static to unit
- Propane 14.0" W.C. static to unit
- Maximum Input:**
- Single 60,000 BTU/hr
- Double 120,000 BTU/hr

MINIMUM ENTRY CLEARANCE:

- Uncrated 25.56" (649mm)
- Crated 37-1/2" (953mm)

SHIPPING INFORMATION:

- Approx. Weight**
- Per section 520 lbs. (236 kg)
- Crate sizes**
- 37-1/2" (952mm) x 43-1/2" (1105mm) x 51-3/4" (1315mm)
- (2 crates required for double)

NOTE: The company reserves the right to make substitutions of components without prior notice

BLODGETT OVEN COMPANY

www.blodgett.com 44 Lakeside Avenue, Burlington, VT 05401 • Phone: (802) 860-3700 • Fax: (802) 864-0183