

# HEAVY DUTY ELECTRIC SOLID HOT PLATE

## Model HDEHP



Thank you for purchasing this product.  
To ensure proper use, we recommend that you  
read this instruction manual before operating the  
unit.

### GENERAL SPECIFICATIONS

Width: 12.0" Depth: 24.0" Height: 11.5"

### ELECTRICAL SPECIFICATIONS

Volts	KW	Amps 1 Phase	Amps Per Line 3 Phase			Type Receptacle Req'd. 1 Phase Only
			L1	L2	L3	
208	3.9	18.7	16.3	9.4	9.4	30A - 240V (NEMA 6 - 30R)
240	5.2	21.7	18.7	10.8	10.8	

Dual voltage units - specify single phase or three phase.

\*Cord supplied with 1 phase, NEMA-6.

## Cecilware sells value... Worldwide

### Cecilware Corporation

43-05 20th Avenue, Long Island City, NY 11105-1295

718-932-1414 Fax: 718-932-7860

800-935-2211 E-Mail: [customer.service@cecilware.com](mailto:customer.service@cecilware.com)

[www.cecilware.com](http://www.cecilware.com)



Operation Manual  
NQ17A December 2006

## **UNPACKING AND INSPECTION:**

Carefully lift your Heavy Duty Electric Solid Hot Plate out of shipping container, and inspect immediately for shipping damage. Install 4-inch legs as follows: Remove the legs from plastic shipping bag, turn your Heavy Duty Electric Solid Hot Plate on its side and screw legs into the four holes provided in bottom.

NOTE: Your Heavy Duty Electric Solid Hot Plate was shipped in a carton designed to give it maximum protection in normal handling. It was thoroughly inspected before leaving the factory and the carrier accepted and signed for it. File any claims for shipping damage or irregularities directly with the carrier, not with company.

## **ELECTRICAL HOOKUP:**

Insert Line Cord Plug into appropriate NEMA Receptacle as specified.

NOTE: A separate circuit should be supplied for each of these Hot Plate with a matched circuit breaker or fuse. Check local codes for compliance in installation.

**WARNING: WARRANTY IS VOID IF HOT PLATE IS CONNECTED TO ANY VOLTAGE OTHER THAN THAT SPECIFIED.**

**WARNING: INSTALL HOT PLATE AT LEAST 1" FROM WALL. DO NOT OPERATE HOT PLATE UNLESS LEGS ARE INSTALLED.**

Before using Hot Plate for the first time, heat up elements for three to five minutes to burn off protective coating. This also hardens the surface of the solid heating elements.

## **\*\* CLEANING INSTRUCTIONS \*\***

The solid heating elements are easily cleaned with a damp cloth after use. Clean up dirt and spills with Ajax and a Scotchbrite pad. After cleaning, rub a few drops of cooking oil into the surface of the elements; then switch on for a few minutes to re-harden. Hot Plate

Use Ajax and a Scotchbrite pad to keep the exterior surfaces of your short order Hot Plate free of dirt and blemishes, rubbing with the grain of the stainless steel. Rinse and wipe dry; then polish with a soft cloth.

These simple procedures will keep your short order Hot Plate clean and sparkling. A well cleaned Hot Plate will give you many years of service.

A circuit diagram has been provided to assist qualified technicians. A Recommended Qualified Service Technician should carry out repairs if needed. Do not remove any components or service panels on this product.

# HEAVY DUTY ELECTRIC GRIDDLES

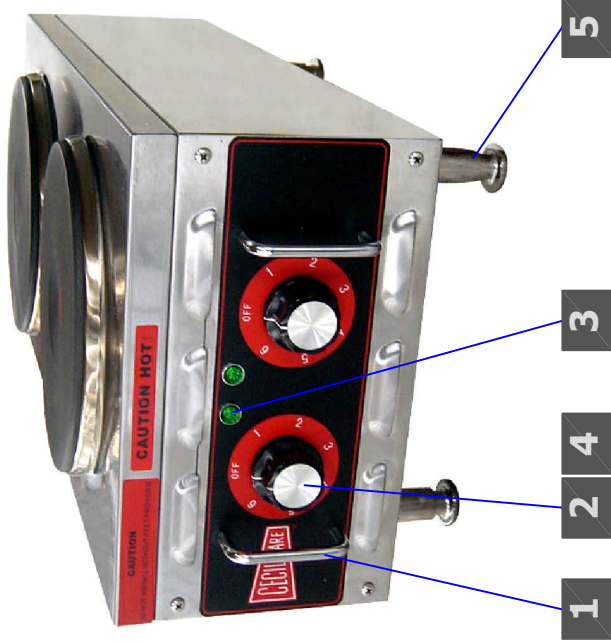

1

2

4

3

5

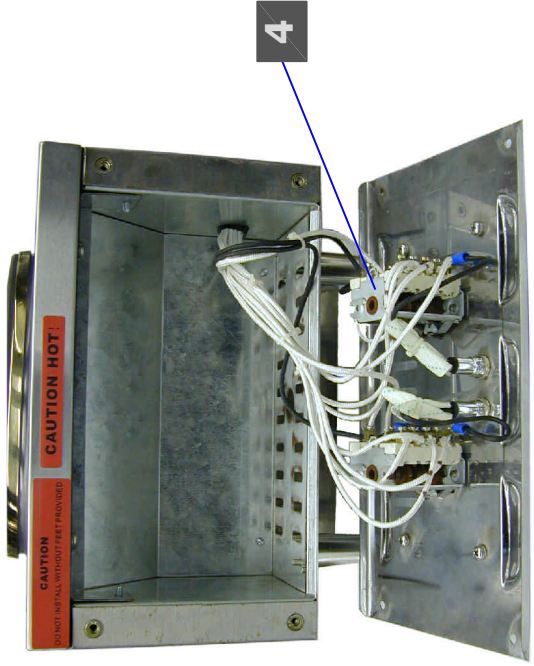

FRONT PANEL REMOVED

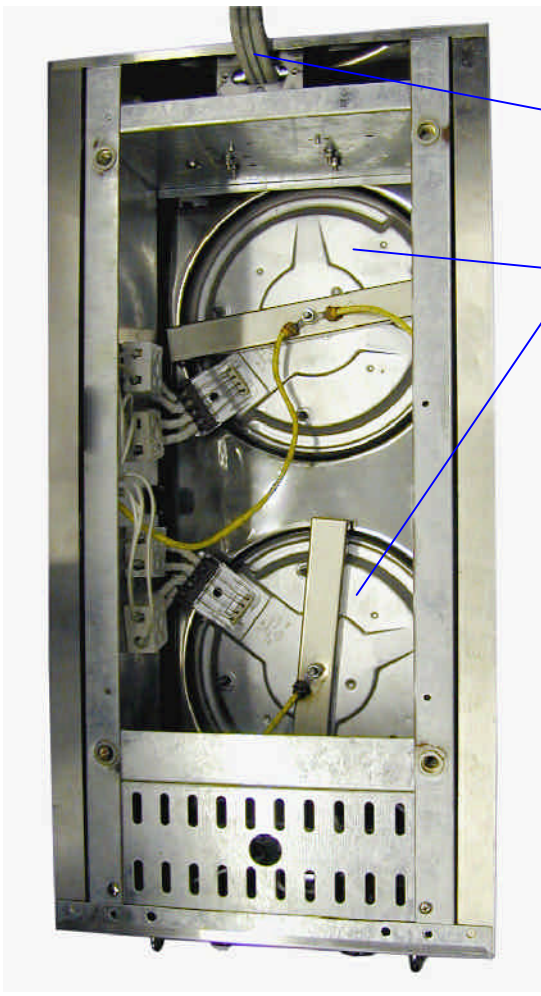

BOTTOM PANEL REMOVED

6

7

## \*\* SPARE PARTS LIST \*\*

Item	Part No.	Description
1	02315	Handle - Chrome
2	02316	Thermostat Knob
3	02318	Indicator Light - Green
4	02319	Power Switch
5	02314	4" Adjustable legs (set of 4)
6	02320	Solid Heater Element
7	C097A	Power Cord

# HEAVY DUTY ELECTRIC SOLID HOT PLATE WIRING DIAGRAMS

Model: HDEHP

240 VOLTS - 60 Hz. - 1 PH. - 5.2 kW.  
L1, L2, + GND

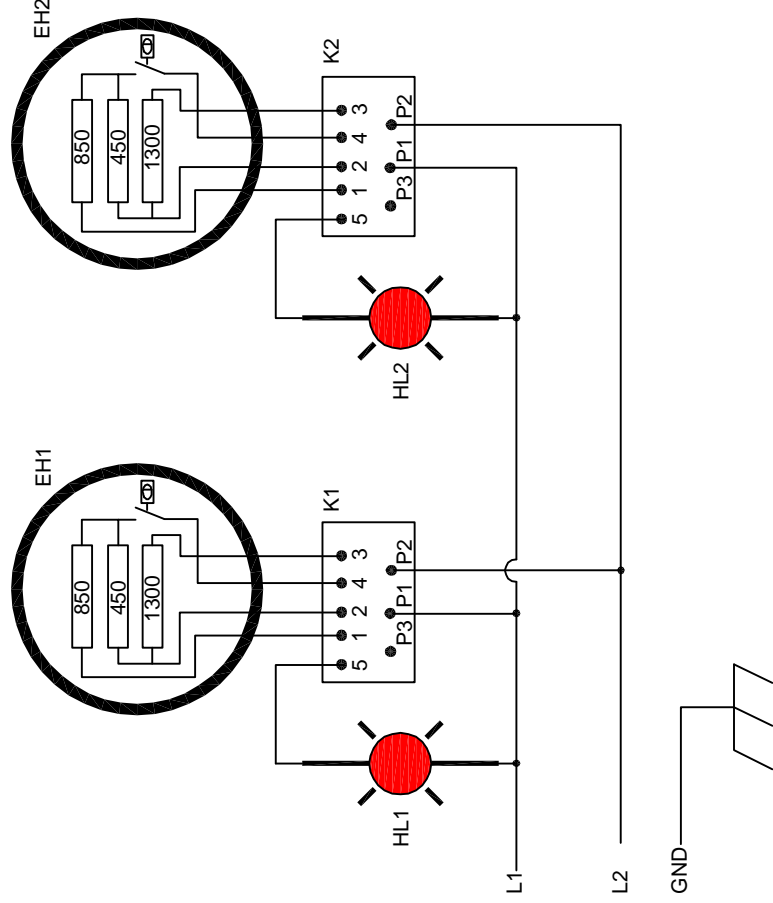

## SWITCH

	P1			P2		
	5	2	1	3	3	4
0						
1	●	●			●	●
2	●	●			●	●
3	●	●			●	
4	●	●			●	●
5	●			●		●
6	●		●			

EH1 - 2: STOVE HEAD    K1 - 2: SWITCH    HL1 - 2: LED