

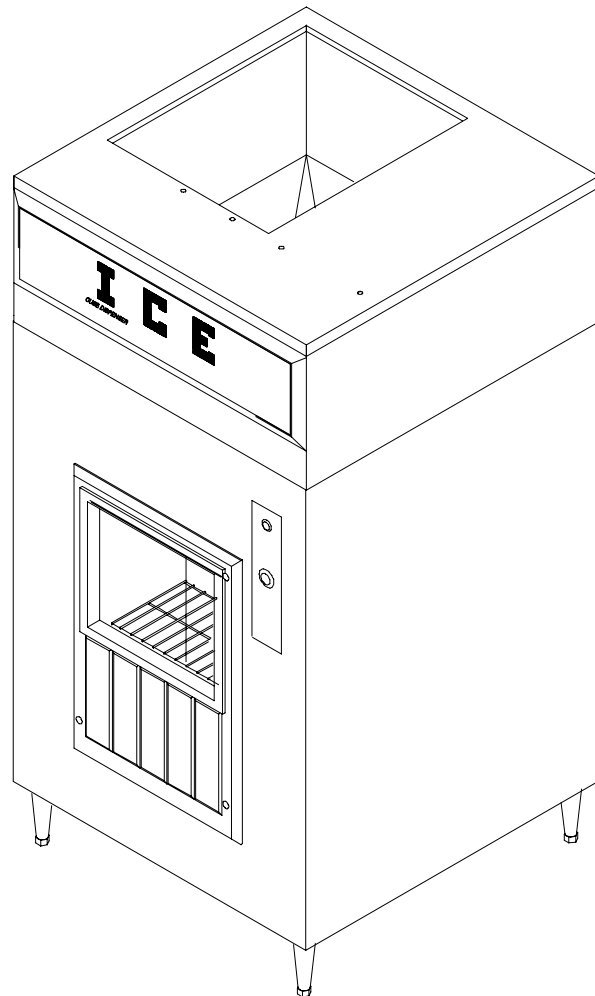

ICE DISPENSER

DPP 230-Push-Button Operated
DPK 230-Key Operated (Optional)
DPC 230-Card Operated (Optional)
DPT 230-Token Operated (Optional)

Installation/Service Manual



Part No. 161952801INS
Release Date: May 30, 2006
Revision: A

THIS DOCUMENT CONTAINS IMPORTANT INFORMATION

This Manual must be read and understood before installing or operating this equipment

TABLE OF CONTENTS

	Page
SAFETY INFORMATION	1
RECOGNIZE SAFETY INFORMATION	1
UNDERSTAND SIGNAL WORDS	1
FOLLOW SAFETY INSTRUCTIONS	1
GENERAL INFORMATION	2
TO THE USER OF THIS MANUAL	2
CLAIMS INSTRUCTIONS	2
WARRANTY REFERENCE INFORMATION	2
DESIGN DATA	2
INSTALLATION	4
SELECTING LOCATION	4
ELECTRICAL REQUIREMENTS	4
INSTALLATION	4
INSTALLING ICE DISPENSER	4
FILLING DISPENSER ICE BIN HOPPER WITH ICE	5
ADJUSTMENTS	5
OPERATION	7
MAINTENANCE	9
CLEANING AND SANITIZING	9
DAILY CLEANING (SEE FIGURE 2)	9
CLEANING AND SANITIZING ICE BIN INTERIOR	9
ADJUSTMENTS	10
FILLING DISPENSER ICE BIN HOPPER	10
TROUBLESHOOTING	12
NO ICE DISPENSED	12
WARRANTY	18

SAFETY INFORMATION

Recognize Safety Information

This is the safety-alert symbol. When you see this symbol on our machine or in this manual, be alert to the possibility of personal injury.

Follow recommended precautions and safe operating practices.



Understand Signal Words

A signal word - **DANGER**, **WARNING**, OR **CAUTION** is used with the safety-alert symbol. **DANGER** identifies the most serious hazards.

Safety signs with signal word **DANGER** or **WARNING** are typically near specific hazards.

General precautions are listed on **CAUTION** safety signs. **CAUTION** also calls attention to safety messages in this manual.



Follow Safety Instructions

Carefully read all safety messages in this manual and on your machine safety signs. Keep safety signs in good condition. Replace missing or damaged safety signs. Learn how to operate the machine and how to use the controls properly. Do not let anyone operate the machine without instructions. Keep your machine in proper working condition. Unauthorized modifications to the machine may impair function and/or safety and affect the machine life.

GENERAL INFORMATION

TO THE USER OF THIS MANUAL

This Manual is a guide for installing and operating this equipment. Refer to Table of Contents for page location of detailed information pertaining to questions that may arise during installation or operation of this equipment.

CLAIMS INSTRUCTIONS

Claims: In the event of shortage, notify the carrier as well as IMI Cornelius immediately. In the event of damage, notify the carrier. **IMI Cornelius is not responsible for damage occurring in transit, but will gladly render assistance necessary to pursue your claim. Merchandise must be inspected for concealed damage within 15 days of receipt.**

WARRANTY REFERENCE INFORMATION

Warranty Registration Date (to be filled out by customer)
Unit Part Number:
Serial Number:
Install Date:
Local Authorized Service Center:

DESIGN DATA

Table 1. Design Data	
Unit Model Numbers:	
DPP 230 Push-Button Operated	
DPK 230 Key-Operated (Optional), 161467-001	
DPC 230 Card Operated (Optional), 161467-002	
DPT 230 Token Operated (Optional), 1614671-000	
Overall Dimensions:	
Height	59-3/8 inches
Width	30 inches
Depth	30 inches
Weights:	
Dry Weight (No ice in ice bin Bin)	170 pounds
Shipping Weight	200 pounds
Capacity:	
Ice Bin Capacity	160 pounds

Table 1. Design Data (cont'd)	
Ambient Operating Temperature	40° F to 100° F
Electrical:	
Average Current Draw	2.5 Amps
Time Delay Fuse Rating	15 Amps
Power Supply (Single Phase)	120 VAC, 60 Hz
Plumbing Connections:	
Bin Drain	1-inch O.D. Vinyl Tube

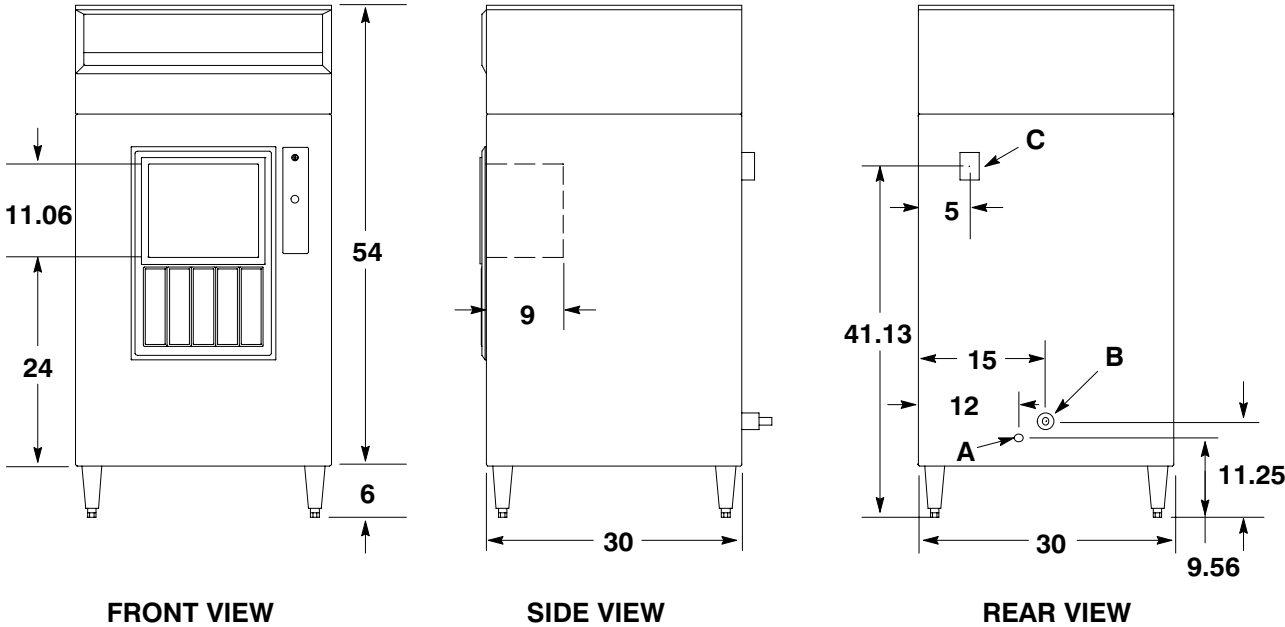

- A CONDENSATE DRAIN 1/2 F.P.T.
- B BIN AND STATION DRAIN 1 IN. VINYL TUBE
- C ELECTRICAL JUNCTION BOX

NOTE: REMOVABLE TOP OF UNIT CUT FOR MOUNTING
CORNELIUS 30" WIDE VERTICAL EVAPORATOR CUBER.

FIGURE 1. DIMENSIONS/DRAIN CONNECTIONS

INSTALLATION

This section of the manual covers installing the dispenser, preparing the dispenser for operation, and operating the dispenser.

SELECTING LOCATION

1. Locate the Ice Dispenser in a cool shaded area close to a properly grounded and fused electrical outlet with proper electrical requirements (**see Table 1 Design Data**).
2. Provide a suitable trapped open drain as close as possible to the area where the Ice Dispenser will be installed. This may be an existing floor drain or a 1 1/4-inch trapped open drain. *All plumbing must be installed according to National and local plumbing codes.*

ELECTRICAL REQUIREMENTS

The electrical supply must be 120V 60 cycle, 1 phase and the unit must be properly grounded. ALL WIRING MUST CONFORM TO NATIONAL AND LOCAL ELECTRICAL CODES. VOLTAGE MINIMUMS: 120V unit – 103 volts minimum. REFER TO SERIAL PLATE FOR MINIMUM CIRCUIT AMPACITY AND MAXIMUM TIME DELAY FUSE SIZE.

INSTALLATION

INSTALLING ICE DISPENSER

1. To uncrate the Ice Dispenser, *carefully* remove the staples holding the crate to the bottom of the skid, then lift the crate up off the Dispenser.
2. *Very carefully* tip the Ice Dispenser over on it's side and remove the four bolts holding the skid to the bottom of the Dispenser, then remove the skid.

NOTE: The leg kit, loose-shipped and found inside the Ice Dispenser, must be installed at this time.

3. Install the four legs in four corners of the Ice Dispenser base as shown in Figure 2.
4. *Very carefully* set the Ice Dispenser in upright position on it's legs in selected operating location. *Make sure* the Ice Dispenser is leveled after placing in operating location.
5. Locate the ice storage bin drain hose (3/4-inch hose) located on back side of the Ice Dispenser (see figure 1) and route it to to the open drain. The storage bin drains by gravity and the drain hose must maintain a gradual slope to the drain for proper draining. *The drain hose should be insulated to prevent condensation from dripping from the hose. Condensation dripping from the drain hoses can cause serious staining of carpeting or hardwood floors.*
6. A separate drain line must be provided for the condensate drain (see figure 1). The parts bag inside the Ice Dispenser contains a plastic 1/2- inch NPT to a 3/4-inch O.D. drain hose fitting that may be used to make the condensate drain hose connection to the Ice Dispenser..

NOTE: Plumbing codes will not allow the ice storage bin drain hose and the condensate drain hose to be tied together which could possibly cause water from the ice bin drain hose to “back up” into the condensate drain hose.

7. Using the condensate drain hose fitting referred to in preceding step 6, Install the fitting in the Ice Dispenser.

8. Connect drain hose to the condensate drain hose fitting , then route drain hose to the open drain. *The drain hose should be insulated to prevent condensation from dripping from the hose. Condensation dripping from the drain hoses can cause serious staining of carpeting or hardwood floors.*
9. The ice bin hopper interior *must* be thoroughly cleaned prior to filling the ice bin hopper with ice in preparation for dispenser operation. Refer to **CLEANING INSTRUCTIONS** and thoroughly clean the ice bin hopper interior.

FILLING DISPENSER ICE BIN HOPPER WITH ICE



WARNING: The ice bin hopper contains hazardous moving parts. The ice rotator is automatically timed to start and move a short distance to break up ice in the ice bin. *Do not* remove the ice bin hopper top cover without first disconnecting electrical power from the dispenser.

IMPORTANT: The use of bagged ice, which has frozen into large chunks, *can void the factory warranty.* The dispenser ice rotator is not designed to be an ice crusher. Use of large chunks of ice which may “jam up” inside the ice bin hopper, may cause failure of the agitator motor and may result in damage to the inside of the ice bin hopper. If bagged ice will be used, it must be completely broken up into small cube-sized pieces before being placed in the ice bin hopper.

Do not use hard-frozen ice. After ice has been removed from the freezer, allow ice to sit at room temperature for approximately 1/2-hour before placing ice in the ice bin hopper. Ice to be used to fill the ice bin hopper *must* be in the form of small cubes, chunklets, or cracked ice (**DO NOT USE FLAKE OR CRUSHED ICE**).

1. Make sure electrical power is disconnected from the dispenser.
2. Observing the preceding **IMPORTANT** note, fill ice bin hopper with small cubes, chunklets, or cracked ice.
3. Install ice bin hopper top cover.

ADJUSTMENTS

All adjustments require access to the inside of the electrical box assembly (see Figure 2). To gain entry to the inside of the electrical box assembly, you must have the key to open the electrical box assembly front panel. Unlock, then pull out and down on the electrical box assembly front panel to expose the MANUAL/PORION CONTROL SWITCH the ICE PORTION SIZE ADJUSTMENT KNOB, and the time delay between dispensed ice portions TIME DELAY ADJUSTMENT SCREW inside the electrical box assembly. Perform the following instructions to make pre-operation adjustments.

Manual/Portion Control Switch.

Inside the electrical box assembly, you will find a MANUAL/PORION CONTROL SWITCH. If it is desired to dispense ice continuously when the dispenser is activated, place the MANUAL/PORION CONTROL SWITCH in the “MANUAL” position.

If the MANUAL/PORION CONTROL SWITCH is placed in the “PORTION” position, a set time of approximately 1/2 to 12-seconds (adjustable) will be established for dispensing a portion of ice when the dispenser is activated (see Ice Portion Size Adjustment).

Place the MANUAL/PORION CONTROL SWITCH in the desired mode of operation.

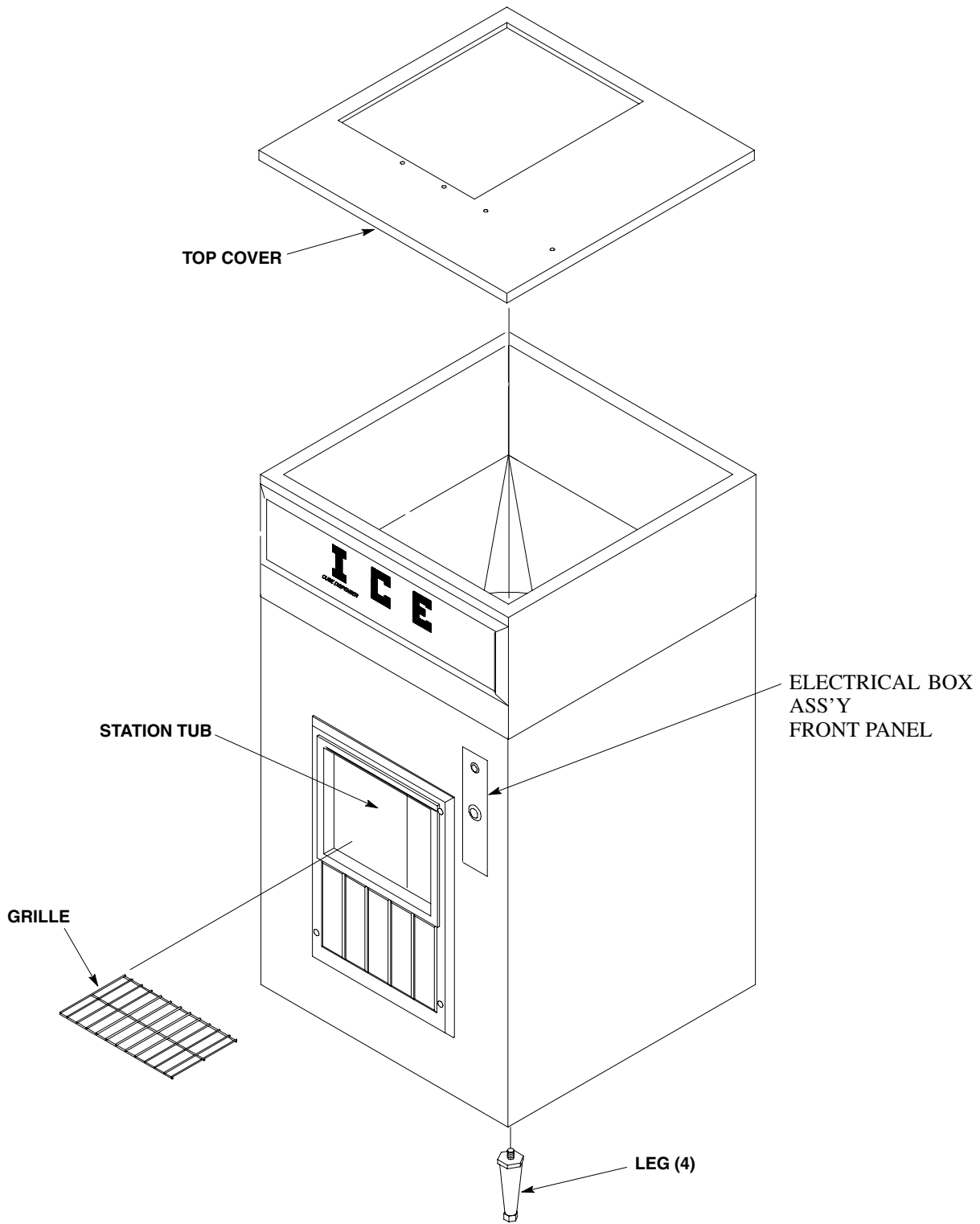

FIGURE 2. DISPENSER COMPONENTS (PUSH-BUTTON MODEL SHOWN)

Ice Portion Size Adjustment.

Located in the rear of the electrical box assembly, you will find the ICE PORTION SIZE ADJUSTMENT KNOB. Turn the ICE PORTION SIZE ADJUSTMENT KNOB to the left (counterclockwise) for less ice dispensed or turn the knob to the right (clockwise) for more ice dispensed.

Adjust the ice portion size as instructed in this paragraph.

Time Delay Between Dispensed Ice Portions Adjustment.

Inside the electrical control box assembly, you will find a time delay between dispensed ice portions TIME DELAY ADJUSTMENT SCREW (blue plastic square box with screw driver slot in center) on the portion control board. The time delay between dispensed ice portions may be adjusted from between 0 and 60-seconds. Turn the TIME DELAY ADJUSTMENT SCREW for more or less time between dispensed ice portions as indicated by adjustment marks on the control board next to the blue plastic square box. This makes it inconvenient to fill the ice chest from the dispenser.

Adjust the time delay between ice portions as instructed in this paragraph.

OPERATION

NOTE: If the dispenser has not vended ice for two hours, an automatic agitation cycle will be initiated by the solid-state portion control and will last approximately two seconds to stir up the ice in the ice bin hopper.

1. Referring to **ELECTRICAL REQUIREMENTS**, connect electrical power to the dispenser.

Manual Dispense Dispenser.

With the MANUAL/PORTION CONTROL SWITCH placed in the "MANUAL" position, pressing the Ice Dispense Switch on the electrical box assembly front panel will activate the dispenser and ice will be dispensed continuously until the switch is released. If the MANUAL/PORTION CONTROL SWITCH is placed in the "PORTION" position, a set time of approximately 1/2 to 12-seconds (adjustable) will be established and pressing the Ice Dispense Switch will dispense that pre-set portion of ice.

Key Operated Dispensers.

A special key must be used to activate the dispenser to dispense ice. With the MANUAL/PORTION CONTROL SWITCH placed in the "MANUAL" position, activating the dispenser key switch on the electrical control box front panel will dispense ice continuously until the key switch is released. If the MANUAL/PORTION CONTROL SWITCH is placed in the "PORTION" position, a set time of approximately 1/2 to 12-seconds (adjustable) will be established and activating the dispenser key switch will dispense that pre-set portion of ice.

Card Operated Dispenser.

A special plastic card must be used to activate the dispenser to dispense ice. With the MANUAL/PORTION CONTROL SWITCH placed in the "MANUAL" position, activating the dispenser with the special plastic card will dispense ice continuously until the card is removed. If the MANUAL/PORTION CONTROL SWITCH is placed in the "PORTION" position, a set time of approximately 1/2 to 12-seconds (adjustable) will be established and activating the dispenser with the special plastic card will dispense that pre-set portion of ice.

Token Operated Dispenser.

A special token must be used to activate the dispenser to dispense ice. With the MANUAL/PORTION CONTROL SWITCH placed in the "MANUAL" position, activating the dispenser with the special token will dispense ice. If the MANUAL/PORTION CONTROL SWITCH is placed in the "PORTION" position, a set time of approximately 1/2 to 12-seconds (adjustable) will be established and activating the dispenser with the special token will dispense that pre-set portion of ice.

MAINTENANCE

This section of the manual describes maintenance procedures to be performed on the dispenser.

CLEANING AND SANITIZING

IMPORTANT: Only qualified Personnel should perform cleaning and sanitizing procedures.

DAILY CLEANING (see Figure 2)

1. Remove grille from the station tub.
2. Wash grille in a water/detergent soap solution, then rinse with warm water.
3. Wash inside of the station tub assembly with a water/detergent soap solution. Rinse inside of the station tub assembly with warm water allowing water to run down the drain hose.
4. Place grille back inside the station tub.
5. Clean all external surfaces of the dispenser with a sponge and water/detergent soap solution. Rinse out sponge with clean water, then wring excess water out of the sponge and wipe off all external surfaces of the dispenser. Wipe dispenser dry with a clean soft cloth. **DO NOT USE ABRASIVE-TYPE CLEANERS.**

CLEANING AND SANITIZING ICE BIN INTERIOR

(see Figure 4)

The ice bin hopper interior should be cleaned and sanitized every 90-days following Sanitizer Manufacturer's recommendations. Use Chlor-Tergent (Oakite Products Inc.) or an equivalent sanitizer.



CAUTION: DO NOT USE CHLORINE CLEANSING POWDERS FOR CLEANING. Use of chlorine cleaning powders will cause corrosive action on the ice bin hopper walls and metal components inside the ice bin hopper.



WARNING: The ice bin hopper contains hazardous moving parts. The ice rotator is automatically timed to start and move a short distance to break up ice inside the ice bin hopper. Do not remove ice bin hopper top cover without first disconnecting electrical power from the dispenser.

NOTE: Lime and scale deposits may be removed from the ice bin walls and metal components inside the ice bin hopper by using a cleaner such as Calgon Liquid Ice Machine Cleaner.

1. Disconnect electrical power from the dispenser.
2. Remove ice bin hopper top cover. Dispense ice from ice bin until bin is basically empty.
3. Using warm water, melt remaining ice inside the ice bin hopper.
4. Remove four knurled screws securing the stainless steel breaker bar inside the ice bin hopper, then remove the breaker bar.
5. Remove bolt and spacer washers securing the ice rotator, then remove rotator from inside the ice bin hopper.

6. Remove drain screen from inside the ice bin.
7. Remove two screws securing the sink top, then remove sink top from the station tub.
8. Remove three screws securing the ice chute and the ice chute back from the upper bin section.
9. Remove grille from the station tub.
10. Using three clean five gallon pails, fill the first pail with approximately three gallons of warm potable water. Fill the second pail with approximately three gallons of a water/detergent soap solution. Using the third pail, prepare three gallons of sanitizing solution by mixing 3 gallons of 70° F to 100° F (max) potable water with .067ounce sanitizer/gallon water. This mixture will provide 200 ppm of chlorine.
11. Using a plastic bristle brush and the water/detergent soap solution, scrub all parts removed in preceding steps 1 through 8 (ice bin hopper top cover, stainless steel breaker bar, ice rotator, sink top, ice chute, ice chute back, grille, and all screws), then rinse all parts in clean water and allow to air dry.
12. Scrub ice bin hopper top rim, ice bin hopper interior, ice bin hopper discharge opening outer surfaces, and sink with the water/detergent soap solution, then rinse with clean water.
13. Clean all external surfaces of the dispenser with a sponge and water/detergent soap solution. Rinse out sponge with clean water, then wring excess water out of the sponge and wipe off all external surfaces of the dispenser. Wipe dispenser dry with a clean soft cloth. **DO NOT USE ABRASIVE-TYPE CLEANERS.**
14. Place all small removed parts in the sanitizing solution and allow them to soak for ten to fifteen minutes (ice bin hopper top cover, stainless steel breaker bar, ice rotator, sink top, ice chute, ice chute back, grille, and all screws).
15. Using a plastic bristle brush and the sanitizing solution, scrub the ice bin hopper top cover, stainless steel breaker bar, ice rotator, sink top, ice chute, ice chute back, grille, and all screws and allow to air dry.
16. Install drain screen, stainless steel breaker bar, ice rotator, ice chute and ice chute back, sink top, and grille on the dispenser by reversing removal procedures.
17. Fill the ice bin hopper with ice as instructed in **FILLING DISPENSER ICE BIN HOPPER** in the **INSTALLATION** section of this manual.
18. Install ice bin hopper top cover.
19. Restore electrical power to the dispenser.
20. Test dispense the dispenser for proper operation.

ADJUSTMENTS

Refer to **ADJUSTMENTS** in **INSTALLATION** section of this manual for all adjustment instructions that may be performed on the dispenser.

FILLING DISPENSER ICE BIN HOPPER

Refer to **FILLING DISPENSER ICE BIN HOPPER** in **INSTALLATION** section of this manual for instructions to fill the ice bin hopper with ice.

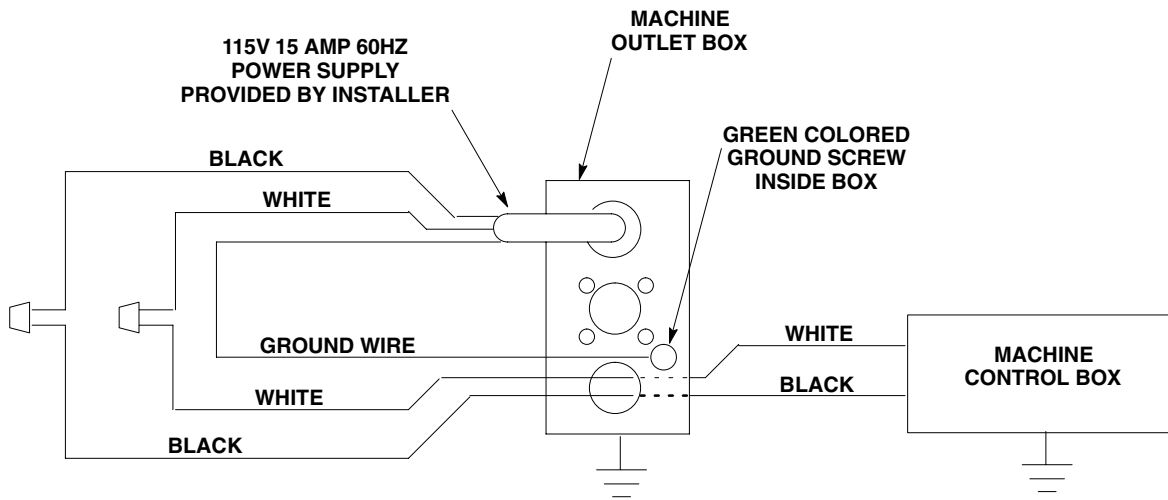

FIGURE 3. WIRING DIAGRAM

TROUBLESHOOTING

Trouble	Probable Cause	Remedy
NO ICE DISPENSED	A. Insufficient ice supply in the ice bin hopper.	A. Replenish ice supply as instructed.
	B. Ice bridged over the ice rotator.	B. Gently tap on the ice to break ice loose.
	C. No electrical power to the dispenser.	C. Restore electrical power to the dispenser.
	D. Ice dispense switch inoperative.	D. Call a qualified Service Person.
	E. Inoperative ice rotator motor.	E. Call a qualified Service Person.
	F. Inoperative start capacitor or start relay	F. Call a qualified Service Person.
	G. Inoperative circuit board	G. Call a qualified Service Person.
	H. Loose or broken electrical wire.	H. Call a qualified Service Person.

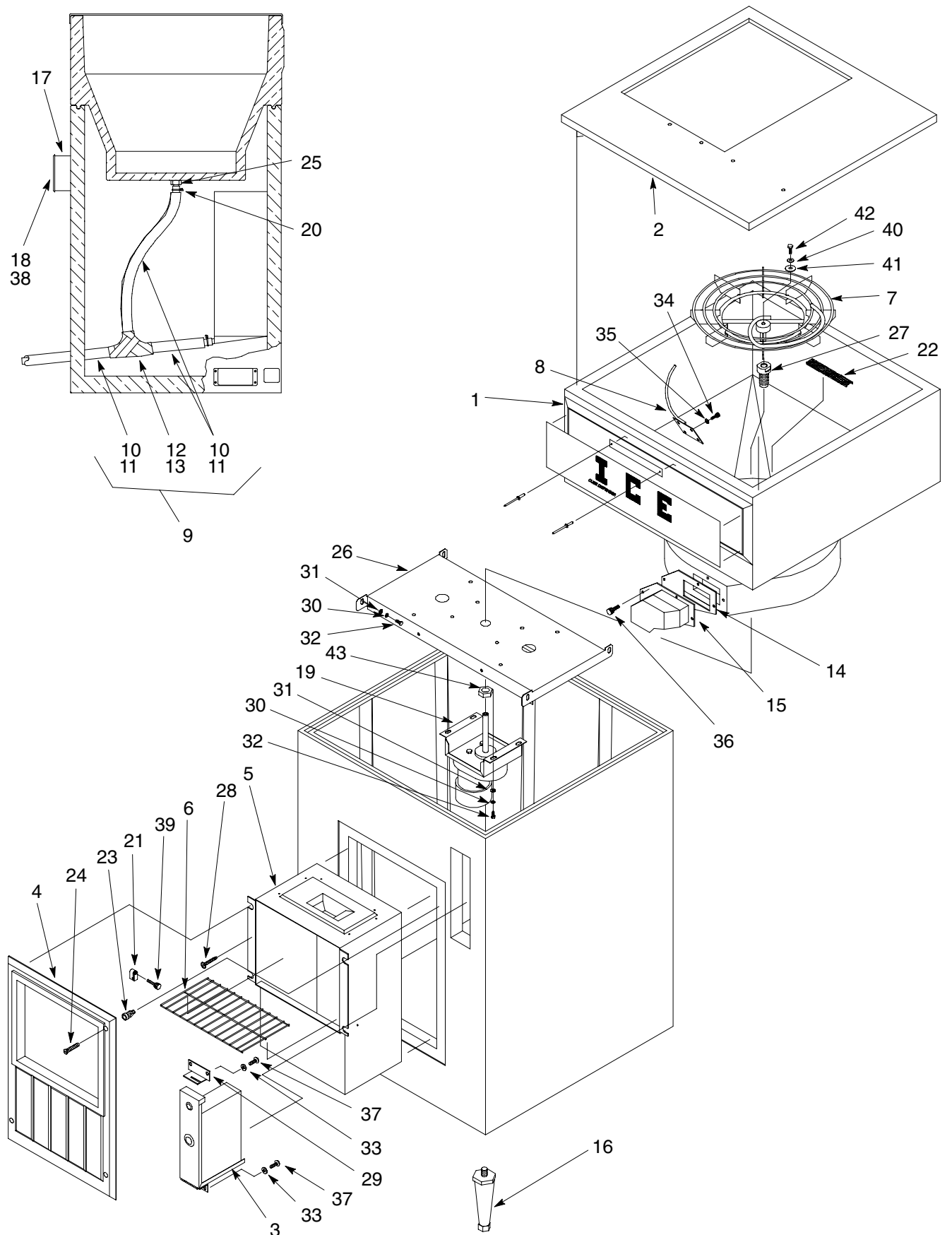

FIGURE 4. ICE DISPENSER

ICE DISPENSER ILLUSTRATED PARTS BREAKDOWN

Item No.	Part No.	Name
1	164503-901	Ice Bin Ass'y, Lower and Upper
2	164874-022	Cover
3	163267-003	Electrical Box Ass'y, Push Button (See Figure 5)
	163267-011	Electrical Box Ass'y, Key (See Figure 5)
	163267-004	Electrical Box Ass'y, Card (See Figure 5)
	163267-013	Electrical Box Ass'y, Token (See Figure 5)
4	161519-001	Panel, Front
5	44615	Tub, Station
6	164896-001	Grille
7	161270-002	Rotator
8	161265-003	Breaker
9	42569	Drain Hose Ass'y (Includes 10-13)
10	169189-004	Tube, .75 I.D. By 8-In. Long
	169189-004	Tube, .75 I.D. By 24-In. Long
	169189-004	Tube, .75 I.D. By 40-In. Long
11	169225-017	Insulation, Tube, .88 I.D. By 6-In. Long
	169225-017	Insulation, Tube, .88 I.D. By 22-In. Long
	169225-017	Insulation, Tube, .88 I.D. By 36-In. Long
12	45830	Clamp, Hose
13	42365	Tee, 3/4-Barb
14	164501-001	Chute, Transition, Back
15	164500-001	Chute, Transition, Front
16	08660	Leg (Not Shown)
17	25872	Handy Box (Not Shown)
18	27602	Cover, Handy Box (Not Shown)
19	44614	Motor Ass'y, Gear
20	38006	Clamp, Hose
21	43708	Clamp, Grille Support
22	44604	Screen, Drain
23	43157	Nut, 1/4-20
24	166042-001	Machine Screw, 1/4-20 By 1 1/4-In. Long
25	41675	Fitting, Drain
26	42556	Plate, Support
27	165635-001	Bearing Shaft Ass'y
28	39610	Sheet Metal Screw, Phil truss Hd., No. 10 By 1 1/4-In. Long

ICE DISPENSER ILLUSTRATED PARTS BREAKDOWN

Item No.	Part No.	Name
29	42553	Plate, Stop, Top
30	00239	Washer, Lock
31	164154	Washer, Flat
32	161189	Machine Screw, 1/4-20 By 5/8-In. Long
33	161176	Washer, Flat
34	161173	Machine Screw, Knurled, No. 8-32 By 1/2-In. Long
35	01470	Washer, Lock
36	161009	Machine Screw, Knurled, No. 10-32 By 1/2-In. Long
37	08387	Machine Screw, Phil Truss Hd., No. 10-32 By 1/2-In. Long
38	167305-001	Sheet Metal Screw, SI Hex Hd., No. 14 By 5/8-In. Long
39	38220	Machine Srew, Knurled, 1/4-20 By 3/4-In. Long
40	168833	Washer, Lock
41	165073-001	Washer, Flat
42	27103	Machine Screw, Hex Hd., 1/4-20 By 1/2-In. long
43	43707	Hex Nut, No. 14

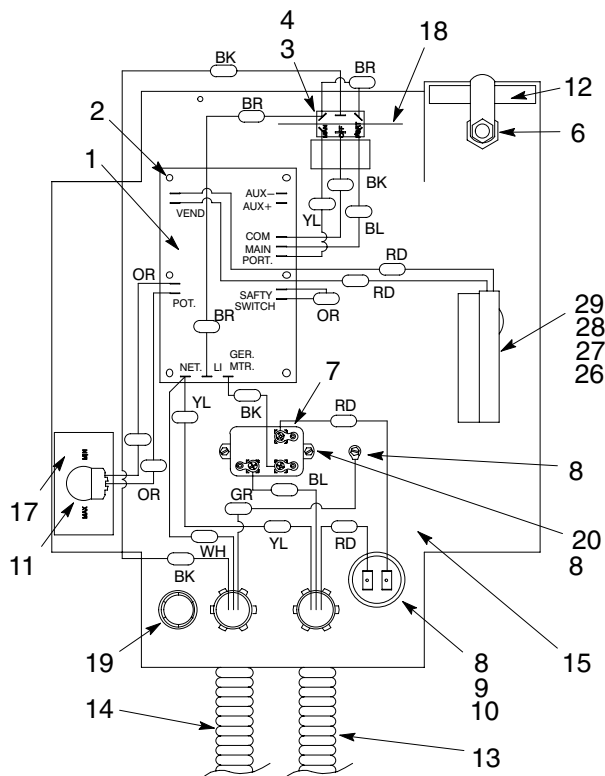

card

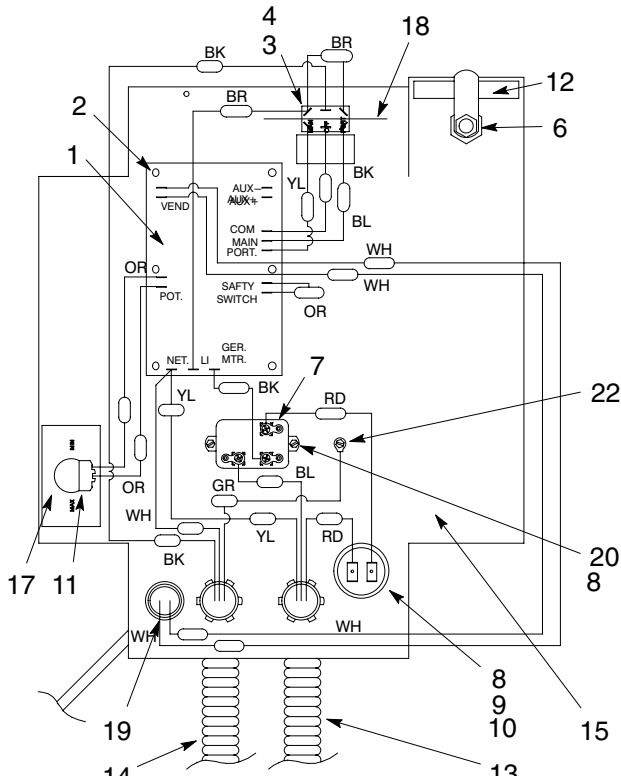

coin

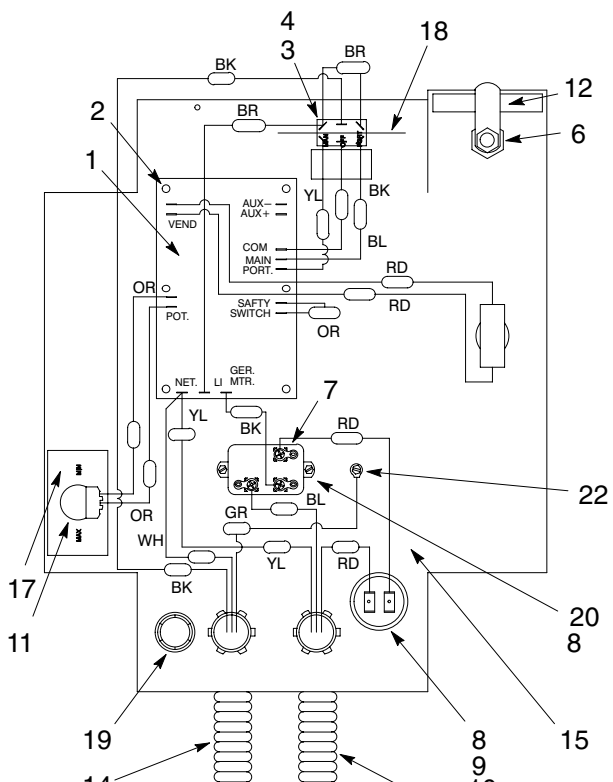

key

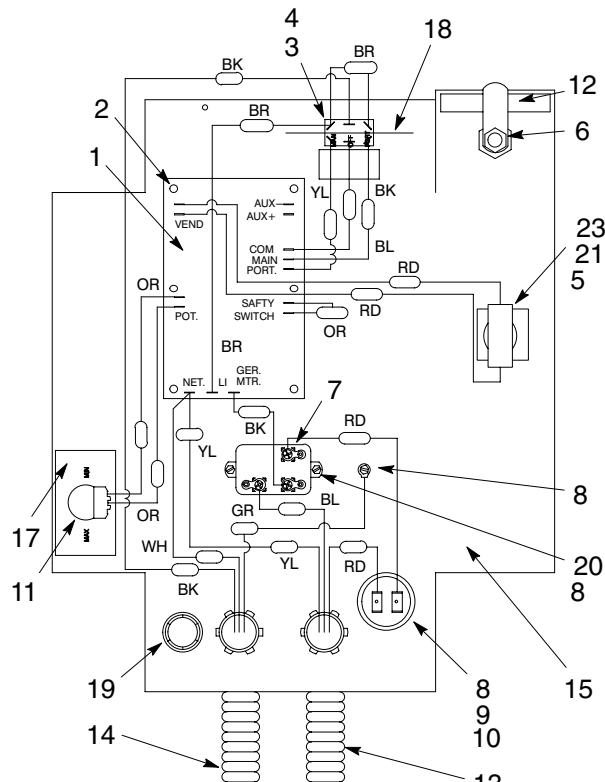

push button

FIGURE 5. ELECTRICAL BOX ASS'Y

ELECTRICAL BOX ILLUSTRATED PARTS BREAKDOWN

Item No.	Part No.	Name
1	36078	Control Board, Portion Control
2	161080	Standoff
3	161297	Switch
4	167410	Thread Rolling Screw, Phil pan Hd., No. 6-32 By 3/8-In. long
5	161297-001	Push Button Kit
6	26128	Lock and Key
7	161627	Relay
8	07578	Thread Cutting Sreew, Phil Pan Hd., No. 8-32 By 3/8-In. long
9	161165	Capacitor
10	161164	Strap, Capacitor
11	28220	Potentiometer Ass'y
12	169071-002	Gasket (Push Button and Card)
	29698	Gasket (Key and Token)
13	42570	Conduit, Motor
14	42571	Conduit, Power
15	42572	Box, Electrical
16	42579	Cover, Electrical Box (Not Shown)
17	09939	Knob, Selector Switch
18	43454	Insulation, Barrier
19	01834	Button Plug (Push Button, Key and Card)
	03611	Snap Bushing (Token)
20	161174	Washer, Star
21	161168-001	Machine Screw, Phil Truss Hd., No. 6-32 By 1/2-In. Long (Push Button)
22	161168-005	Machine Screw, Hex Washer Hd., No. 8-32 By 1/2-In. Long (Key and Token)
23	163296-001	Support, Push Button Kit (Push Button)
24	163545-002	Switch, Key (Not Shown; Key)
25	163267-009	Card (Not Shown; Card)
26	167570-001	Switch, Lockout (Card)
27	163267-008	Shield, Cover (Card)
28	21632	Machine Screw, Rd Hd, No. 4-40 By 3/4-In. Long (Card)
29	21633	Hex Nut, No. 4-40 (Card)

WARRANTY

IMI Cornelius Inc. warrants that all equipment and parts are free from defects in material and workmanship under normal use and service. For a copy of the warranty applicable to your Cornelius product, in your country, please write, fax or telephone the IMI Cornelius office nearest you. Please provide the equipment model number, serial number and the date of purchase.

Locate the office in your area on the Cornelius web site, www.cornelius.com, under the contacts tab.

IMI CORNELIUS INC.



www.cornelius.com
(800) 238-3600