



## MODELS INCLUDED

- WB-14-12



**CAUTION:** Please use this setup procedure before attempting to use this brewer. Failure to follow the instructions can result in injury or the voiding of the warranty.



**CAUTION:** DO NOT connect this unit to hot water. The inlet valve is not rated for hot water.



**WARNING:** DO NOT place this water boiler closer than six [6] inches from wall. Unit must have adequate cross-ventilation.



**WARNING HOT LIQUID,** Scalding may occur. Avoid splashing.



ISO 9001 REGISTERED

WILBUR CURTIS COMPANY  
Montebello, CA 90640

# *Curtis* WILBUR CURTIS COMPANY, INC.

## Water Boiler, 14 Gallon – Instructions

### Important Safeguards/Conventions

This appliance is designed for commercial use. Any servicing other than cleaning and maintenance should be performed by an authorized Wilbur Curtis service center.

- To reduce the risk of fire or electric shock, do NOT open side or bottom panel. No user serviceable parts inside.  
Repair should be performed only by authorized service personnel.
- Keep hands and other items away from hot parts of unit during operation.
- Never clean with scouring powders, bleach or harsh implements.



### Conventions



**WARNINGS – To help avoid personal injury**



**Important Notes/Cautions – from the factory**



**Sanitation Requirements**

**The Curtis Water Boiler is Factory Pre-Set and Ready to Go... Right from the Carton.**

### Factory Settings:

- Water Temperature = 200°F
- Volume = 14 Gallons

### System Requirements

- Water Source: 20 – 100PSI (Min Flow Rate of 1 GPM)
- Electrical: See attached schematic for standard model or visit [www.wilburcurtis.com](http://www.wilburcurtis.com) for your model.

Equipment to be installed to comply with applicable federal, state, or local plumbing/electrical codes having jurisdiction.

### SETUP STEPS

1. Place unit at counter height, on a firm, level base, in such a way that it can be connected to water and power supply.
2. Install the supplied water faucet on the faucet shank in front of the unit.
3. Connect water line to inlet fitting on valve. It is recommended that some type of water mineral reducing filter be used in the water line before entering the unit. Water pressure entering boiler is must be stable and provide minimum of 1 gallon per minute. Use water regulator for constant pressure. Required water pressures, 20 to 100 psi. Turn on water valve.
5. Hook-up power to the unit (refer to schematic for power requirements).
6. Turn on the circuit running power to unit. The water inlet valve will open, filling the unit. When the boiler has filled, turn on boiler at the thermostat, twisting the knob clockwise.
7. Heating tank will require 50 to 60 minutes to attain operating temperature. Thermostat indicator will light at this time.



The National Sanitation Foundation requires the following water connection:

1. A quick disconnect or additional coiled tubing (at least 2x the depth of the unit) so that the machine can be moved for cleaning underneath.
2. In some areas an approved backflow prevention device may be required between the boiler and the water supply.

# Illustrated Parts List

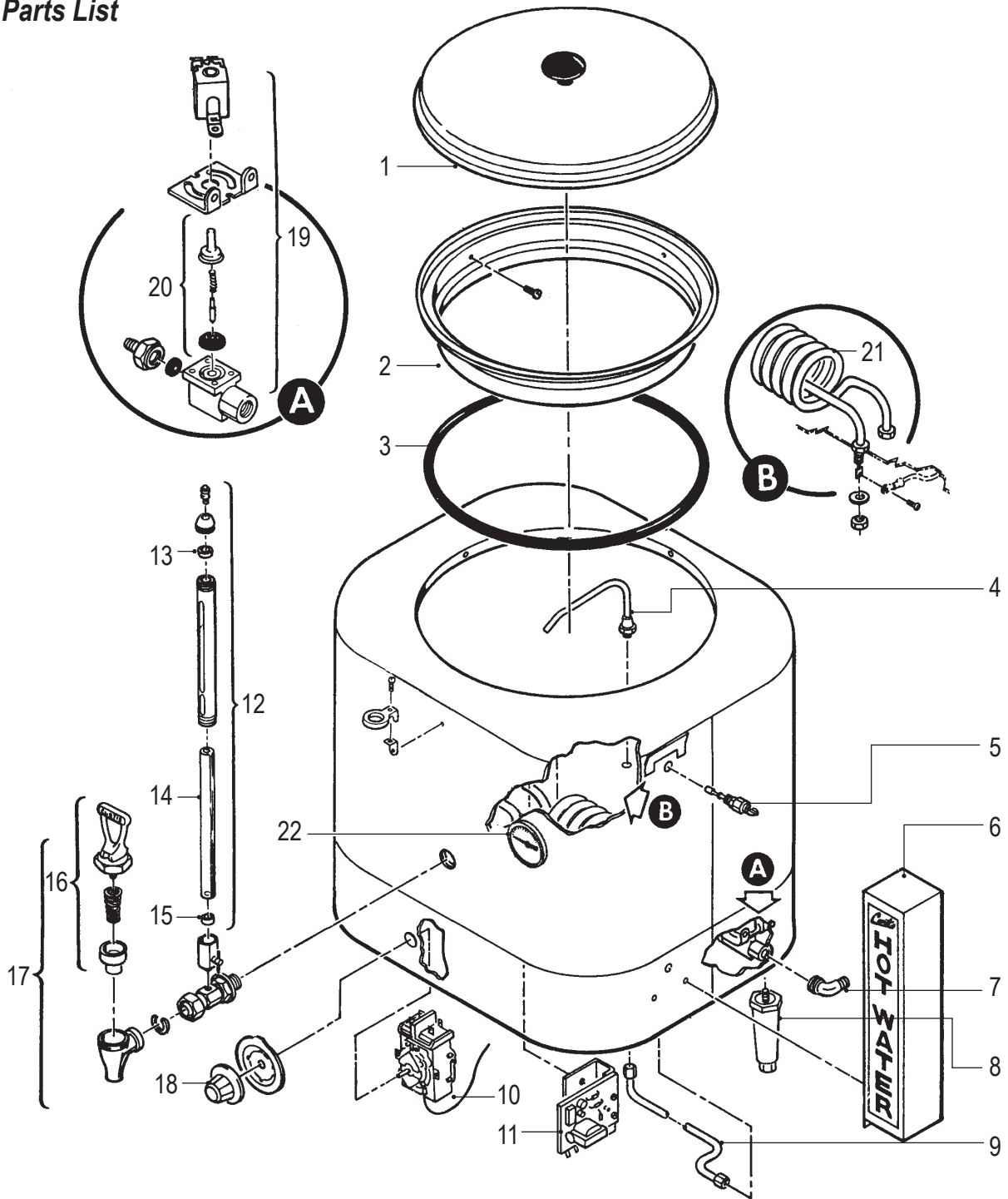

ITEM	PART N°	DESCRIPTION
1	WC-5602	LID, 6 GAL WITH KNOB
2	WC-6118-01	COLLAR, TOP
3	WC-4303	"O" RING, LINERS RU
4	WC-5335	TUBING, 8" WATER INLET
5	WC-5502	PROBE, WATER LEVEL
6	WC-5510	COVER, PROBE WA WB14
7	WC-2401	ELBOW, 3/8 NPT X 1/4 FLRE PLTD
8	WC-3500	LEG, 4" ADJUSTABLE 3/8-16 THRD
9	WC-5334	TUBING, 15-1/2" WATER INLET
10	WC-37137	KIT, THERMOSTAT WB-14
11	WC- 608	LEVEL CONTROL, WATER 120V

ITEM	PART N°	DESCRIPTION
12	WC-2100	GAUGE GLASS ASSY, 7"
13	WC-2005	WASHER, 1/8" SHIELD CAP
14	WC-2024	GLASS, GAUGE 7"
15	WC-2006	WASHER, 3/16" SHIELD BASE
16	WC-3705	REPAIR KIT, S FAUCET
17	WC-1800HW	FAUCET, S' SERIES H/W
18	WC-3217	KNOB, ELECTRIC THERMOSTAT
19	WC- 801	VALVE, WATER INLET
20	WC-3700	REPAIR KIT, INLET VALVE
21	WC- 922-04	HEATING ELEMENT, 3500W, 220V
22	WC- 511	THERMOMETER, DIAL RU'S

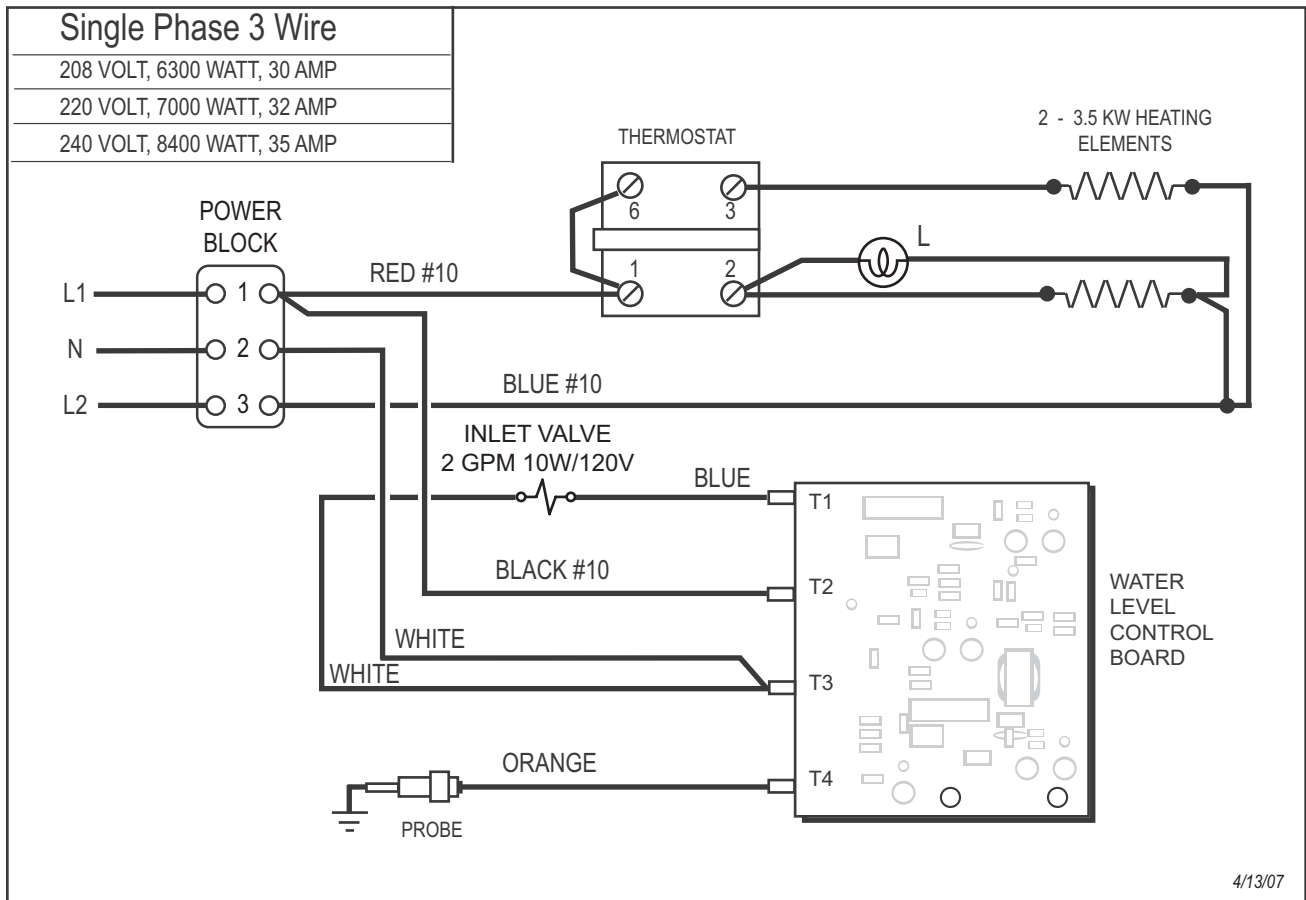
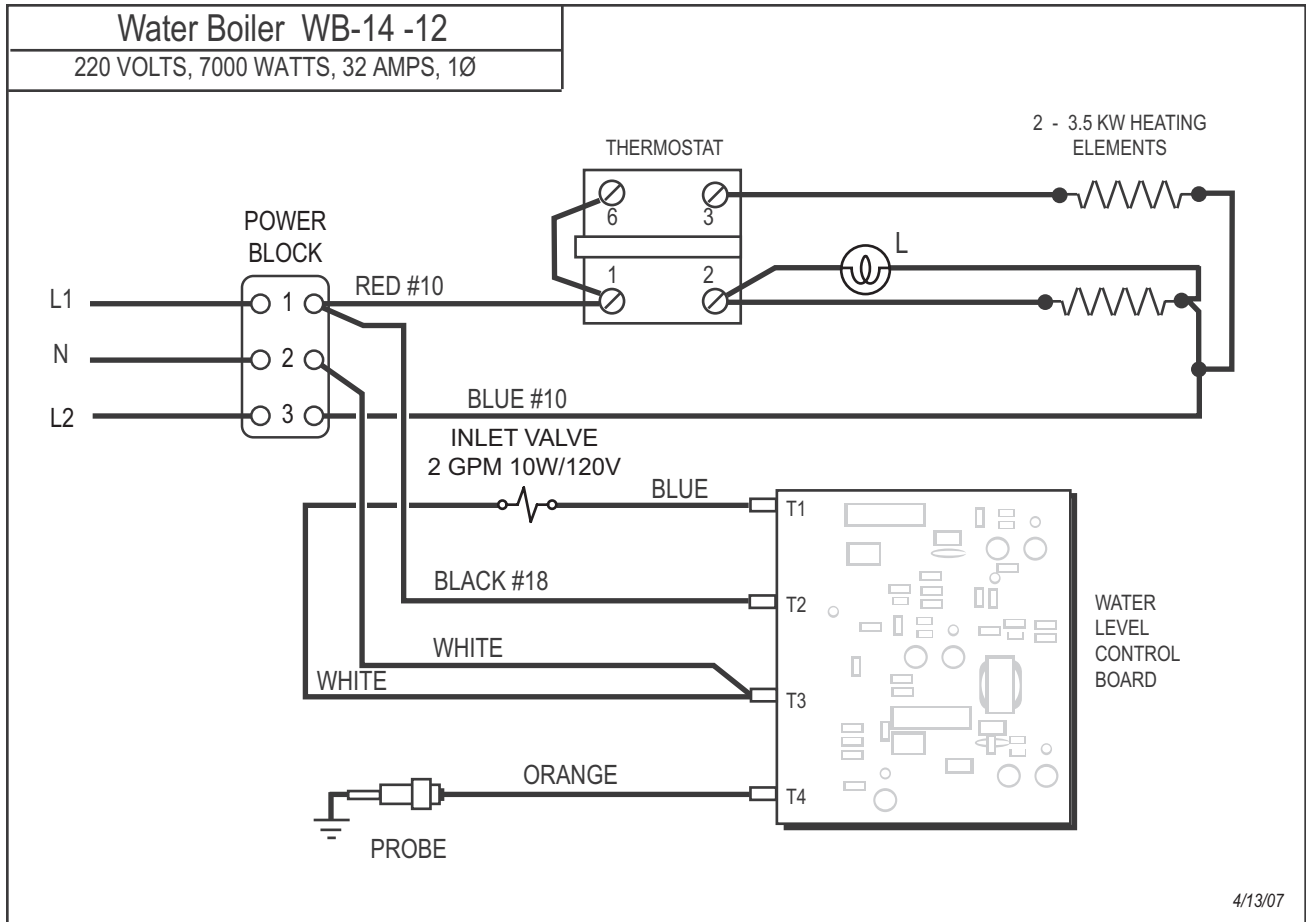

## Electric Thermostat Adjustment

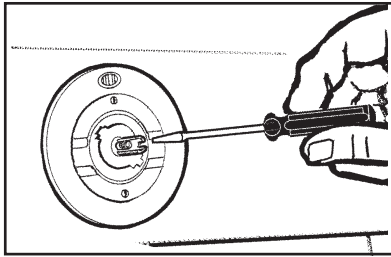

### ELECTRIC THERMOSTAT ADJUSTMENT

On electric water boilers, thermostats are set at the factory to cut off at 200°F. We do not recommend changing this. If necessary, adjustment is as follows:

1. Rotate the thermostat knob to the right to the BOIL position. Pull off the knob.
2. Locate the tiny adjustment screw, inside the stem (see figure 1). Using a small screwdriver, adjust the temperature up or down:
  - a. By turning the screw ¼ turn to the left will increase the temperature about 20°F.
  - b. Turning ¼ to the right will decrease the temperature by 20°F.
  - c. To set the thermostat precisely at 200°F, insert a thermometer probe into the water jacket through the steam hole (just under the sprayhead). Turn the screw ½ turn to the left.
  - d. When the thermometer reaches 200°F, slowly turn the adjustment screw to the right until the pilot light turns off.

## Product Warranty Information

The Wilbur Curtis Company certifies that its products are free from defects in material and workmanship under normal use. The following limited warranties and conditions apply:

- 3 Years, Parts and Labor, from Original Date of Purchase on digital control boards.
- 2 Years, Parts, from Original Date of Purchase on all other electrical components, fittings and tubing.
- 1 Year, Labor, from Original Date of Purchase on all electrical components, fittings and tubing.

Additionally, the Wilbur Curtis Company warrants its Grinding Burrs for Forty (40) months from date of purchase or 40,000 pounds of coffee, whichever comes first. Stainless Steel components are warranted for two (2) years from date of purchase against leaking or pitting and replacement parts are warranted for ninety (90) days from date of purchase or for the remainder of the limited warranty period of the equipment in which the component is installed.

All in-warranty service calls must have prior authorization. For Authorization, call the Technical Support Department at 1-800-995-0417. Effective date of this policy is April 1, 2003.

Additional conditions may apply. Go to [www.wilburcurtis.com](http://www.wilburcurtis.com) to view the full product warranty information.

### CONDITIONS & EXCEPTIONS

The warranty covers original equipment at time of purchase only. The Wilbur Curtis Company, Inc., assumes no responsibility for substitute replacement parts installed on Curtis equipment that have not been purchased from the Wilbur Curtis Company, Inc. The Wilbur Curtis Company will not accept any responsibility if the following conditions are not met. The warranty does not cover and is void under the following circumstances:

- 1) Improper operation of equipment: The equipment must be used for its designed and intended purpose and function.
- 2) Improper installation of equipment: This equipment must be installed by a professional technician and must comply with all local electrical, mechanical and plumbing codes.
- 3) Improper voltage: Equipment must be installed at the voltage stated on the serial plate supplied with this equipment.
- 4) Improper water supply: This includes, but is not limited to, excessive or low water pressure, and inadequate or fluctuating water flow rate.
- 5) Adjustments and cleaning: The resetting of safety thermostats and circuit breakers, programming and temperature adjustments are the responsibility of the equipment owner. The owner is responsible for proper cleaning and regular maintenance of this equipment.
- 6) Damaged in transit: Equipment damaged in transit is the responsibility of the freight company and a claim should be made with the carrier.
- 7) Abuse or neglect (including failure to periodically clean or remove lime accumulations): Manufacturer is not responsible for variation in equipment operation due to excessive lime or local water conditions. The equipment must be maintained according to the manufacturer's recommendations.
- 8) Replacement of items subject to normal use and wear: This shall include, but is not limited to, light bulbs, shear disks, "O" rings, gaskets, silicone tube, canister assemblies, whipper chambers and plates, mixing bowls, agitation assemblies and whipper propellers.
- 9) Repairs and/or Replacements are subject to our decision that the workmanship or parts were faulty and the defects showed up under normal use. All labor shall be performed during regular working hours. Overtime charges are the responsibility of the owner. Charges incurred by delays, waiting time, or operating restrictions that hinder the service technician's ability to perform service is the responsibility of the owner of the equipment. This includes institutional and correctional facilities. The Wilbur Curtis Company will allow up to 100 miles, round trip, per in-warranty service call.

**RETURN MERCHANDISE AUTHORIZATION:** All claims under this warranty must be submitted to the Wilbur Curtis Company Technical Support Department prior to performing any repair work or return of this equipment to the factory. All returned equipment must be repackaged properly in the original carton. No units will be accepted if they are damaged in transit due to improper packaging. **NO UNITS OR PARTS WILL BE ACCEPTED WITHOUT A RETURN MERCHANDISE AUTHORIZATION (RMA). RMA NUMBER MUST BE MARKED ON THE CARTON OR SHIPPING LABEL.** All in-warranty service calls must be performed by an authorized service agent. Call the Wilbur Curtis Technical Support Department to find an agent near you.



WILBUR CURTIS CO., INC.

6913 Acco St., Montebello, CA 90640-5403 USA

Phone: 800/421-6150 ♦ Fax: 323-837-2410

♦ Technical Service Phone: 800/995-0417 (M-F 5:30A - 4:00P PST) ♦ E-Mail: [techservice@wilburcurtis.com](mailto:techservice@wilburcurtis.com)

♦ Web Site: [www.wilburcurtis.com](http://www.wilburcurtis.com)

**FOR THE LATEST SPECIFICATION INFORMATION GO TO [WWW.WILBURCURTIS.COM](http://WWW.WILBURCURTIS.COM)**