



Food Warmers/Holding Stations/Spreader Cabinets

Project _____
 Item _____
 Quantity _____
 CSI Section 11400 _____
 Approval _____
 Date _____

Models

- FWH-1 Food warmer with cafeteria pan Spreader Cabinet SD
 FWH-1A Food warmer with scoop pan Spreader Cabinet SC



* FWH-1

Food warmer and holding station with cafeteria pan.



* FWH-1A

Food warmer and holding station with scoop-type pan.

Standard Features

Food Warmer:

- Durable 6" W x 23-3/4" L (15.4 x 60.3 cm) aluminum alloy housing construction, easy to clean
- 750W radiant heat - 120V/60 Hz/1 Ph 6.3 A
- Ceramic heating element with wire guard
- "ON/OFF" toggle switch on front
- 6 ft. (1.8 M) cord with plug

Holding Stations:

- Stainless steel cafeteria pan, 12" x 20" x 2-1/2" (30.5 x 50.8 x 6.4 cm) with mesh screen
- Scoop-type, perforated pan, 13-1/2" x 18-1/2" x 5-1/4" (34.3 x 47.0 x 13.3 cm)

Specifications

Designed to keep prepared food fresh and hot

Food warmers and holding stations are optional accessories that can be used with Frymaster spreader cabinets and fryers to maintain optimal temperature of prepared food. Food Warmers are available separately to fit existing Frymaster spreader cabinets.

The rectangular food warmer produces an 18" (45.7 cm) heat pattern over the entire length of the unit to keep cooked food at optimal temperature with radiant heat to assure peak flavor without cooking or drying. The shell is manufactured

with durable aluminum alloys and is easy to clean. "ON/OFF" toggle switch, and a 6' (1.8 M) cordset are mounted in the shell. Mounting brackets and hardware are provided for installation.

These units are NSF, UL, and CUL approved and can be used with either the cafeteria-style pan with mesh screen or with the perforated, curved scoop pan for quick, easy bagging.

*Frymaster food warmers and holding stations are not free standing. -- must order with a Frymaster spreader cabinet.



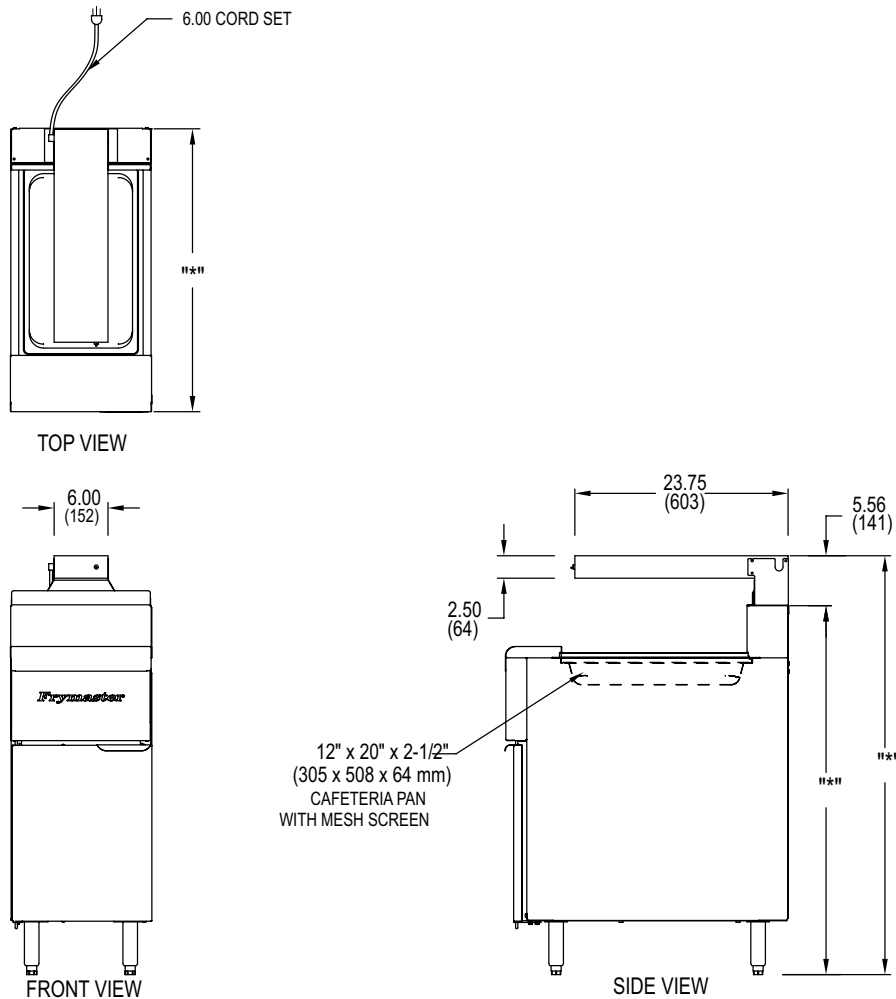

DIMENSIONS

DESCRIPTION	DEPTH	WIDTH	LENGTH
Food warmer	2-1/2" (6.4 cm)	6" (15.4 cm)	23-3/4" (60.3 cm)
Food warmer (CE)	2-1/4" (5.7 cm)		
Cafeteria-style holding pan	2-1/2" (6.4 cm)	12" (30.5 cm)	20" (50.8 cm)
Scoop-style holding station	5-1/4"*** (13.3 cm)	13-1/2" (34.3 cm)	18-1/2" (47.0 cm)

***Depth is shown for deepest point in pan.

SPREADER CABINETS SD & SC

MODEL	DIMENSIONS
H55/OCF30 gas	15-5/8" W x 31-1/2" L x 45-5/8" H(*) (39.7 x 79.9 x 115.8 cm)
MJ45/MJ45E/MJ35/MJ35E	15-5/8" W x 31-1/2" L x 46" (*)H (39.7 x 79.9 x 116.8 cm)
RE14/17/22 / RE14TC/17TC/22TC/ OCF30 electric	15-5/8" W x 31" L x 45-1/2" H(*) (39.7 x 78.6 x 115.2 cm)
MJCF/MJCFE	20-7/8" W x 39-7/8" L x 46-1/8" H(*) (52.9 x 101.3 x 117.2 cm)

POWER REQUIREMENTS

Domestic: 120V 1 Ph 6.3 A 750 W

CE: 230/240 1 Ph 2.1 A 500 W

CAUTION:

Locate heat lamp no closer than 3" (7.6 cm) to a side wall and 16-1/2" (42.0 cm) above a flammable surface.

HOW TO SPECIFY

The following description will assist with ordering the features desired for this equipment:

- FWH-1 Food warmer and holding station with cafeteria pan
- FWH-1A Food warmer and holding station with scoop pan.
- SD Stainless steel door, enamel cabinet
- SC Stainless steel door and cabinet

8700 Line Avenue
Shreveport, LA 71106-6800
USA

Tel: 318-865-1711
Tel: 1-800-221-4583
Fax: 318-868-5987
E-mail: info@frymaster.com

www.frymaster.com
Bulletin No. 818-0061
Printed 9/10
Revised 9/15/11
Litho in U.S.A. ©Frymaster

