

Project

Item #

Quantity



GLOBE FOOD EQUIPMENT COMPANY

Vegetable Cutters

GFP500/GFP550



GFP500



GFP550



GFP500/ GFP550 Vegetable Cutters

Models

- GFP500 Vegetable Cutter
- GFP550 Chef's Choice Vegetable Cutter
Creates Brunoise (small diamond shape) and Gaufrette (waffle design) cuts

Advanced cutting technology improves product yield, increases product shelf life, and reduces costs.

Standard Features

- Powerful 1/2 HP gear driven motor
- Optimum plate speed of 340 RPMs
- Thermal overload protection
- Polished cast aluminum construction
- Double safety interlock - hopper head and food pusher
- Ergonomic 45° food hopper incline
- Removable hopper head and food pusher (no tools required)
- Discs are rigid cast aluminum
- Stainless steel knives are hardened, ground, leathered, and hand polished
- 38 discs are available for the GFP500
- 43 discs are available for the GFP550

Optional Accessories

- Vertical disc storage case (1 disc)
- Horizontal disc storage case (3 discs)
- Horizontal disc storage case (4 discs)
- 3 peg wall rack

Standard Warranty

- 2 years parts and labor

Approved By: _____

Date: _____



GLOBE FOOD EQUIPMENT COMPANY

www.globeslicers.com

2153 Dryden Rd.
Dayton, OH 45439
Phone: 937-299-5493
Phone: 800-347-5423
Fax: 937-299-4147



Vegetable Cutters

GFP500/GFP550

Motor: 1/2 HP, 115-60-1, 2.8 amps, automatic reset thermal overload protection.

On/Off Latch: The hopper latch serves as the on/off switch and interlock for the hopper head. The unit will not operate with the hopper head open or unlatched.

Gear Drive: Sealed planetary gear transmission with permanent grease lubrication. Output 340 RPMs.

Design: Ergonomic 45° incline for convenient feeding, cutting, and ejection of food. Separate food hopper permits continuous cutting of long products. The food pusher enables even pressure to be applied when cutting food. The hopper head, food pusher and cutting discs are easily removable, without the use of tools, for quick cleaning.

Interlocks: The vegetable cutter will operate only if the hopper head is closed and latched. In addition, the vegetable cutter will operate only when the food pusher is covering the food hopper opening.

Cord and Plug: Attached 6-foot flexible 3-wire cord and plug fits a grounded receptacle.

Construction: The housing, removable hinged hopper head, food hoppers, removable food pusher and ejector plate are made of polished cast aluminum.

Cutting Discs: There are 38 (model GFP500) and 43 (model GFP550) cutting discs available. The discs are rigid cast aluminum. The knives are hardened, ground, leathered, and hand polished to a razor sharp edge for precision cutting and long life.

Capacity: Processes up to 600 lbs. per hour. Ideal for up to 300 servings per meal.

Specifications

Dimensions:

Foot Print = 9.87" x 11.87" (25cm x 30cm)
Overall Length = 18" (45.7cm)
Overall Width = 10.25" (26cm)
Overall Height = 20.75" (52.7cm)
Kidney Shaped Hopper = 2.37" x 5" (6cm x 12.7cm)
Continuous Feed Hopper = GFP500 - 2.12" (5.4cm) diameter
GFP550 - 1.62" x 2" (4.1cm x 5.1cm) dia.
Freight Class: 77.5
Net Weight: 36 lbs. (16 kgs.)
Shipping Weight: 45 lbs. (20 kgs.)
Shipping Dimensions: 30"W x 15"D x 17"H (76.2cm W x 38.1cm D x 43.2cm H)

Cutting Discs Available:

Slicing	inches	mm
F1-5	1/32	1
F2-5	5/64	2
G3-5	1/8	3
G4-5	5/32	4
G6-5	15/64	6
G8-5	5/16	8
G10-5	3/8	10
G12-5	15/32	12
SU5-5*	3/16	5
SU8-5*	5/16	8
*(SU discs are wavy slices)		
TO-5	3/16	5

Shredding	inches	mm
11-5	5/64	2
9-5	3/32	2.5
7-5	1/8	3
4-5	5/32	4
3-5	3/16	5
1-5	9/32	7
0-5	23/64	9
00-5	7/16	11
23-5	3/32	2.5

Shaving	inches	mm
HS-5	1/64	.5

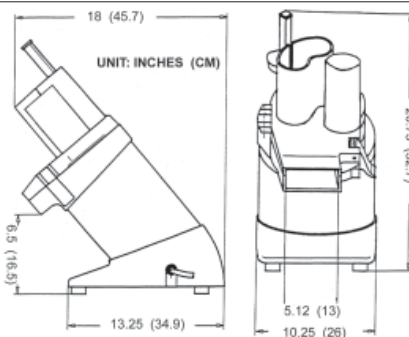

Grating

14-5 fine cut (parmesan and romano cheese powder)

Julienne	inches	mm
S1.5-5	1/16	1.5
S2-5	5/64	2
S3-5	1/8 x 5/64	3 x 2
PA4-5	5/32	4
PA5-5	3/16 x 5/32	5 x 4
BT7-5	9/32	7

French Fry	inches	mm
BT6-5	15/64	6
BT8-5	5/16	8
BT10-5	3/8	10

Cubing	inches	mm
W8-5	5/16	8
W10-5	3/8	10
W14-5	9/16	14

Dicing	inches	mm
P8-5	5/16 x 5/16 x 1/8	8 x 8 x 3
W6-5	1/4 x 1/4 x 5/16	6 x 6 x 8
W20-5	29/32 x 29/32 x 9/16	23 x 23 x 14
W28-5	1 1/8 x 1 1/8 x 9/16	28 x 28 x 14

For GFP550 Only

Brunoise	inches	mm
BR3-5	1/8	3
BR4-5	5/32	4
BR5-5	7/32	5

Gaufrette	inches	mm
PG4-5	5/32	4
PG6-5	15/64	6

Disc Value Package:

DISC3PK-5 (includes an F2-5, G4-5, 3-5, and a WR3)

Disc Storage Cases:

SCV-1 Vertical Case (one disc, excluding the cubing and french fry discs)

SCH-3 Horizontal Case (three discs)

SCH-4 Horizontal Case (four discs)

WR-3 3 Peg Wall Rack (three discs)



GLOBE FOOD EQUIPMENT COMPANY

www.globeslicers.com

2153 Dryden Rd.
Dayton, OH 45439
Phone: 937-299-5493
Phone: 800-347-5423
Fax: 937-299-4147

Printed in U.S.A. 3-2008

Specifications are subject to change without notice.