

# OPERATOR MANUAL

IMPORTANT INFORMATION, KEEP FOR OPERATOR

This manual provides information for:

# smartsteam™

BOILERLESS STEAMER 100

## MODELS SSB-3G/5G/10G & (2)SSB-3G/5G/10G Domestic SMARTSTEAM100™ BOILERLESS STEAMER

- Self Contained
- Gas Heated
- Capacity: SSB-3G=3 Steamer Pans Per Cavity  
SSB-5G=5 Steamer Pans Per Cavity  
SSB-10G=10 Steamer Pans Per Cavity



**THIS MANUAL MUST BE RETAINED FOR FUTURE REFERENCE. READ, UNDERSTAND AND FOLLOW THE INSTRUCTIONS AND WARNINGS CONTAINED IN THIS MANUAL.**

### FOR YOUR SAFETY

Do not store or use gasoline or other flammable vapors and liquids in the vicinity of this or any other appliance.

### POST IN A PROMINENT LOCATION

Instructions to be followed in the event user smells gas. This information shall be obtained by consulting your local gas supplier. As a minimum, turn off the gas and call your gas company and your authorized service agent. Evacuate all personnel from the area.

### WARNING

Improper installation, adjustment, alteration, service or maintenance can cause property damage, injury or death. Read the installation, operating and maintenance instructions thoroughly before installing or servicing this equipment.

### NOTIFY CARRIER OF DAMAGE AT ONCE

It is the responsibility of the consignee to inspect the container upon receipt of same and to determine the possibility of any damage, including concealed damage. Unified Brands suggests that if you are suspicious of damage to make a notation on the delivery receipt. It will be the responsibility of the consignee to file a claim with the carrier. We recommend that you do so at once.

Manufacture Service/Questions 888-994-7636.

Information contained in this document is known to be current and accurate at the time of printing/creation. Unified Brands recommends referencing our product line websites, [unifiedbrands.net](http://unifiedbrands.net), for the most updated product information and specifications.

PART NUMBER 145144, REV. L (10/09)

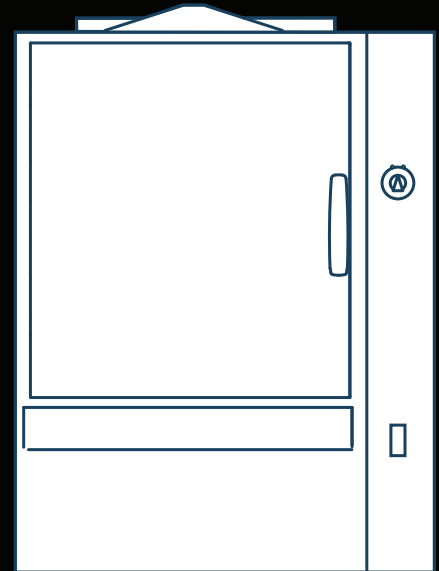

1055 Mendell Davis Drive  
Jackson, MS 39272

888-994-7636, fax 888-864-7636  
[groen.com](http://groen.com)

## **IMPORTANT — READ FIRST — IMPORTANT**

- WARNING:** THE UNIT MUST BE INSTALLED BY PERSONNEL QUALIFIED TO WORK WITH ELECTRICITY AND PLUMBING. IMPROPER INSTALLATION CAN CAUSE INJURY TO PERSONNEL AND/OR DAMAGE TO THE EQUIPMENT. THE UNIT MUST BE INSTALLED IN ACCORDANCE WITH APPLICABLE CODES.
- CAUTION:** SHIPPING STRAPS ARE UNDER TENSION AND CAN SNAP BACK WHEN CUT.
- CAUTION:** DO NOT INSTALL THE UNIT IN ANY WAY WHICH WILL BLOCK THE REAR VENTS, OR WITHIN 2 INCHES OF A HEAT SOURCE SUCH AS A BRAISING PAN, DEEP FRYER, CHAR BROILER OR KETTLE.
- CAUTION:** LEVEL THE UNIT FRONT TO BACK, AND PITCH IT SLIGHTLY TO THE FRONT, TO AVOID DRAINAGE PROBLEMS.
- WARNING:** FOLLOW THE WIRING DIAGRAM EXACTLY WHEN CONNECTING A UNIT TO AVOID DAMAGE OR INJURY. WIRING DIAGRAM IS LOCATED ON THE INSIDE OF THE RIGHT PANEL.
- CAUTION:** DO NOT USE PLASTIC PIPE. DRAIN MUST BE RATED FOR BOILING WATER.
- WARNING:** DO NOT CONNECT THE DRAIN DIRECTLY TO A BUILDING DRAIN.
- WARNING:** BLOCKING THE DRAIN IS HAZARDOUS.
- IMPORTANT:** IMPROPER DRAIN CONNECTION WILL VOID WARRANTY.
- IMPORTANT:** DO NOT ALLOW ANY WATER TRAPS IN THE DRAIN LINE. A TRAP CAN CAUSE PRESSURE TO BUILD UP INSIDE THE CAVITY DURING STEAMING, WHICH WILL MAKE THE DOOR GASKET LEAK.
- WARNING:** WHEN YOU OPEN THE DOOR, STAY AWAY FROM STEAM COMING OUT OF THE UNIT. STEAM CAN CAUSE BURNS.
- WARNING:** BEFORE CLEANING THE OUTSIDE OF THE STEAMER, DISCONNECT THE ELECTRIC POWER SUPPLY. KEEP WATER AND CLEANING SOLUTIONS OUT OF CONTROLS AND ELECTRICAL COMPONENTS. NEVER HOSE OR STEAM CLEAN ANY PART OF THE UNIT.
- WARNING:** ALLOW COOKING CHAMBER TO COOL COMPLETELY BEFORE CLEANING.
- WARNING:** USE MILD CLEANING AGENTS ONLY. CAREFULLY READ THE WARNINGS AND FOLLOW THE DIRECTIONS ON THE LABEL OF EACH CLEANING AGENT. USE SAFETY GLASSES AND RUBBER GLOVES AS RECOMMENDED BY CLEANING AGENT MANUFACTURER.
- WARNING:** DO NOT PUT HANDS OR TOOLS INTO THE COOKING CHAMBER UNTIL THE FAN HAS STOPPED TURNING.
- WARNING:** DO NOT OPERATE THE UNIT UNLESS THE REMOVABLE RIGHT SIDE PANEL HAS BEEN RETURNED TO ITS PROPER LOCATION.
- NOTICE:** DO NOT USE A CLEANING AGENT THAT CONTAINS ANY SULFAMIC ACID, OR ANY CHLORIDE, INCLUDING HYDROCHLORIC ACID. IF THE CHLORIDE CONTENT OF ANY PRODUCT IS UNCLEAR, CONSULT THE MANUFACTURER. DO NOT USE A CLEANING OR DELIMING AGENT THAT CONTAINS MORE THAN 30% PHOSPHORIC ACID.
- NOTICE:** DO NOT USE ANY DEGREASER THAT CONTAINS POTASSIUM HYDROXIDE OR SODIUM HYDROXIDE OR THAT IS ALKALINE.
- WARNING:** USE OF ANY REPLACEMENT PARTS OTHER THAN THOSE SUPPLIED BY GROEN OR THEIR AUTHORIZED DISTRIBUTOR VOIDS ALL WARRANTIES AND CAN RESULT IN BODILY INJURY TO THE OPERATOR AND DAMAGE THE EQUIPMENT. SERVICE BY OTHER THAN FACTORY-AUTHORIZED PERSONNEL WILL VOID ALL WARRANTIES.
- WARNING:** HIGH VOLTAGE EXISTS INSIDE CONTROL COMPARTMENTS. DISCONNECT FROM BRANCH CIRCUIT BEFORE SERVICING. FAILURE TO DO SO CAN RESULT IN INJURY OR DEATH.

# Table of Contents

OPERATOR WARNINGS.....	2
REFERENCES.....	3
EQUIPMENT DESCRIPTION.....	4
INSPECTION AND UNPACKING .....	4
INSTALLATION AND STARTUP .....	5
OPERATION .....	9
CLEANING.....	11
MAINTENANCE .....	13
TROUBLESHOOTING.....	13
PARTS LIST.....	15
WIRING DIAGRAM .....	19
SERVICE LOG .....	20
WARRANTY PROTECTION .....	21

## References

UNDERWRITERS LABORATORIES, INC.  
333 Pfingsten Road  
Northbrook, Illinois 60062

NFPA/70 The National Electrical Code

NSF INTERNATIONAL  
789 N. Dixboro Rd.  
P.O. Box 130140  
Ann Arbor, Michigan 48113-0140

NATIONAL FIRE PROTECTION ASSOCIATION  
60 Batterymarch Park  
Quincy, Massachusetts 02269

NFPA/ 54 The National Fuel Gas Code

## Equipment Description

Your Groen SSB-3G/5G/10G or (2)SSB-3G/5G/10G SmartSteam100 Boilerless Steamer is designed to give years of service. It has a stainless steel cavity (cooking chamber) which is served by a gas-heated atmospheric steam generating reservoir. A powerful blower circulates the steam in the cavity to increase heating efficiency.

Each cavity holds up to three, five or ten steam table pans (12" x 20" x 2 1/2" deep) as shown below.

SSB Steamer	PANS PER CAPACITY PER TYPE			
	12 x 20 x 2-1/2 (steamer)	12 x 20 x 4 (steamer)	13 x 18 (half size bake)	18 x 26 (bake)
SSB-3G	3	2	0	0
(2)SSB-3G	6	4	0	0
SSB-5G	5	3	0	0
(2)SSB-5G	10	6	0	0
SSB-10G	10	6	20	10
(2)SSB-10G	20	12	40	20

An 18-gauge stainless steel case encloses the cavity, the steam generating reservoir and the control compartment that houses electrical components. Door hinges are field-reversible (the door may be set to open from the left or right). Operating controls are on the front panel.

The SSB- 3G/5G/10G steamers are equipped with electronic controls. These units are readily identified by their unique control panels. Steamer function is controlled by touch pad controls and a rotary timer dial.

The drain system on all models includes a spray condenser, which cools drain water.



## Inspection and I

Your Groen SmartSteam100 Boilerless Steamer will be delivered completely assembled in a heavy shipping carton strapped to a skid. On receipt, inspect carton carefully for exterior damage.

**CAUTION**  
**SHIPPING STRAPS ARE UNDER TENSION AND CAN SNAP BACK WHEN CUT.**

Carefully cut the straps and detach the sides of the carton from the skid. Pull the carton up off the unit. Be careful to avoid personal injury or equipment damage from staples which might be left in the carton walls.

When starting installation, check packing materials to make sure loose parts such as the condensate drip tray are not discarded with this material.

SSB Steamer	Weight (LBS)	Weight (KGS)
SSB-3G Table Top	240	109
SSB-3G W/Stand	310	141
(2) SSB-3G W/Stand	475	215
SSB-5G Table Top	272	123
SSB-5G W/Stand	345	156
(2)SSB-5G W/Stand	555	252
SSB-10G W/Stand	452	205
(2)SSB-10G W/Stand	764	347

Write down the model number, serial number and installation date. Keep this information for reference. Space for these entries is provided at the top of the Service Log in the back of this manual.

# Installation and Startup

## WARNING

THE UNIT MUST BE INSTALLED BY PERSONNEL WHO ARE QUALIFIED TO WORK WITH GAS, ELECTRICITY AND PLUMBING. IMPROPER INSTALLATION CAN CAUSE INJURY TO PERSONNEL AND/OR DAMAGE TO THE EQUIPMENT. THE UNIT MUST BE INSTALLED IN ACCORDANCE WITH APPLICABLE CODES. THE UNIT MUST BE INSTALLED BY A LICENSED PLUMBER OR GAS FITTER WHEN INSTALLED WITHIN THE COMMONWEALTH OF MASSACHUSETTS.

## CAUTION

DO NOT INSTALL THE UNIT WITH THE REAR VENTS BLOCKED OR WITHIN 2 INCHES OF A HEAT SOURCE SUCH AS A BRAISING PAN, DEEP FAT FRYER, CHARBROILER OR KETTLE.

TO AVOID DRAINAGE PROBLEMS, LEVEL THE UNIT FRONT TO BACK, AND PITCH SLIGHTLY TO THE FRONT.

### 1. Installation

Minimum Clearances: SmartSteam100 Boilerless Steamer requires the following minimum clearances to any surface, combustible or non-combustible.

<b>Right Side</b>	<b>2 inches</b>
<b>Left Side</b>	<b>2 inches</b>
<b>Rear</b>	<b>6 inches</b>

Steam Free Zone: The SmartSteam100 Boilerless Steamer can be damaged by steam from external sources. **Do not install** the steamer over a steam venting drain. Ensure that steam is not present in an area bounded by the footprint of the steamer and a circle 18 inches in radius about the right rear corner of the steamer (see figure below).

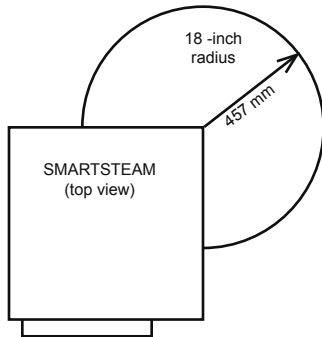

Install and operate the gas appliance in a well ventilated area. Adequate air must be supplied to replenish the air used for combustion. Installation must conform with local codes and/or with the National Fuel Gas Code, ANSI Z223.1/NFPA-54 (latest edition) or the National Gas and Propane Code CSA B149.1 as applicable.

Any item which might obstruct or restrict the flow of air for combustion and ventilation must be removed. Do not obstruct the flue cover or rear vents after installation.

THE AREA DIRECTLY AROUND THE APPLIANCE MUST BE CLEARED OF ALL COMBUSTIBLE MATERIAL. FAILURE TO FOLLOW THESE INSTRUCTIONS CAN CAUSE BODILY INJURY AND/OR PROPERTY DAMAGE.

The steamer must be **disconnected** from the gas supply system during any pressure testing of that system which has test pressures in excess of  $1/2$  PSI (3.45 kPa).

### 2. Electrical Supply Connection

Provide 115 VAC, 60 HZ, 1 PH, 15 AMP service. Bring wire in through hole in the lower left back panel. Each cavity requires a separate cord for connections. Local codes and/or the National Electrical Code should be observed in accordance with ANSI/NFPA 70. **AN ELECTRICAL GROUND IS REQUIRED.** The wiring diagram is located in the service compartment and in this manual. Maximum load is  $2\frac{1}{2}$  AMPs. In Canada, provide electrical service in accordance with the Canadian Electrical Code, CSA C22.2 Part 1 and/or local codes.

### 3. Gas Supply Connection

Connection to the gas supply shall be in accordance with the chart below.

SSB-Steamer	NPT Pipe Size Required
SSB-3G	$1/2$
(2)SSB-3G	$1/2$
SSB-5G	$1/2$
(2)SSB-5G	$1/2$
SSB-10G	$3/4$
(2)SSB-10G	$3/4$

## Ratings for Gas SmartSteam100

\*Measured on top of gas valve

	BTU	*Operating Pressure	MIN Incoming Gas Feed Rate	MAX Incoming Gas Feed Rate
3G NG	54,000	4.30" WC	5" WC	14" WC
3G LP	54,000	10.5" WC	12" WC	14" WC
5G NG	62,000	4.25" WC	5" WC	14" WC
5G LP	62,000	10.5" WC	12" WC	14" WC
10G NG	106,000	4.30" WC	5" WC	14" WC
10G LP	106,000	10.5" WC	12" WC	14" WC

In Canada, the installation must conform to the Canadian Gas Code, CAN 1-B149, Installation Codes for Gas Burning Appliances and Equipment and/or local codes.

After the unit has been connected to the gas supply, all gas joints must be checked for leaks. **Do NOT use flame checking for leaks.** A thick soap solution or other suitable leak detector should be used.

### For a Unit on casters:

A. The installation shall be made with a connector that complies with the standard for connectors for movable gas appliances; ANSI Z21.69.CSA 6.16, and a quick-disconnect device that complies with the standard for quick-disconnect devices for use with gas fuel, ANSI Z21.41.CSA 6.9.

B. Adequate means must be provided to limit the movement of the appliance without depending on the connector and the quick-disconnect device or its associated piping to limit the appliance movement.

C. The location where the restraining device may be attached to the appliance shall be in accordance with Groen specifications for the device.

### 4. Water Connection(s)

Install a check valve to prevent back flow in the incoming cold water line, as required by local plumbing codes. Water pressure in the line should be between 30 and 60 PSI. If pressure is above 60 PSI, a pressure regulator will be needed. These pressures must provide the **1.5 gallons per minute** required for proper steamer function.

A 3/4 inch female NH connector (garden hose type) is used to attach the water supply to the inlet valve. **Minimum inside diameter of the**

**water feed line is 1/2 inch. Use a washer in the hose connection.** Do not allow the connection to leak, no matter how slowly. Do not over-tighten hose connections.

This equipment is to be installed to comply with the basic plumbing code of the Building Officials and Code Administrators International, Inc. (BOCA) and the Food Service Sanitation Manual of the Food and Drug Administration (FDA).

NOTE: Local code may also require check valves in the water supply line.

### 5. Drain Connection

Level the steamer front to back, and pitch it slightly to the rear (maximum 1/4 inch) by adjusting the optional legs or the bullet feet on the optional stand.

SSB-Steamer	Drain ID Hose Size Required (IN)
SSB-3G	1.5"
(2)SSB-3G	2.5"
SSB-5G	1.5"
(2)SSB-5G	2.5"
SSB-10G	2.0"
(2)SSB-10G	2.0"

### WARNING:

**DO NOT CONNECT THE DRAIN DIRECTLY TO A BUILDING DRAIN. BLOCKING THE DRAIN IS HAZARDOUS.**

There must be a free air gap between the end of the hose and the building drain. The free air gap should be as close as possible to the unit drain. There must also be no other elbows or restrictions between the unit drain and the free air gap.

### CAUTION

**DO NOT USE PLASTIC PIPE. DRAIN MUST BE RATED FOR BOILING WATER.**

Install the drain line with a constant downward pitch.

**IMPORTANT: Do not allow water traps in the line. A trap can cause pressure in the cavity, which may cause the door gasket to leak.**

**Proper Drain Line Connection — Drain Line must have a constant downward pitch of at least 1/4" per foot. Observe local code regarding air gap spacing and drain connections.5.**



**IMPROPER DRAIN LINE CONNECTION**

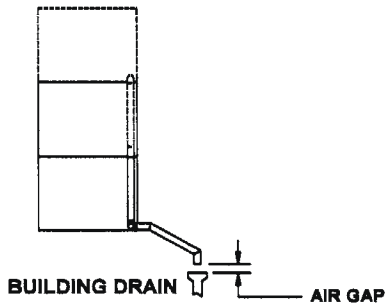

**D. Drain Connection**

Steamers must be leveled front to back, and pitched to the front (maximum  $\frac{1}{4}$  inch) by adjusting the bullet feet on the cabinet or stand base.

For all factory-stacked SSB steamers, a 2 $\frac{1}{2}$  inch ID hose is attached to the unit drain. It must be rated for boiling water.

**7. Counter-Mounted Units**

This section is applicable if the steamer will be mounted to a counter. All four edges of the bottom of the steamer must be sealed with RTV to the counter if the 4 inch legs are not used. Counter must be made of a noncombustible material such as metal or tile.

**WARNING:  
DO NOT STACK SSB STEAMERS WHEN LEGS  
ARE USED.**

**6. Factory-Stacked Units**

This section is applicable only if you are installing factory-stacked units.

Installing stacked steamers is similar to installing a single unit. The steamers are stacked and assembled at the factory and delivered with the water connections and drain hoses required for a single point connection.

**A. Water Connection**

The same water supply connection is used for both units. At the water inlet valve a  $\frac{3}{4}$  inch female NH connector (garden hose type) is used for the water supply.

**B. Electrical Supply Connection**

Separate electrical connections will be required for each steamer to be stacked. Each steamer unit must have its own branch circuit protection.

**C. Gas Connection**

A single gas connection is required for both steamers. Gas supply must be adequate under all conditions as listed on page 6.

## Initial Startup

After the SmartSteam100 Boilerless Steamer has been installed, test it to ensure that the unit is operating correctly.

1. Remove all literature and packing materials from the interior and exterior of the unit.
2. Make sure the water supply line is open.
3. Make sure that the gas supply line is open and that the manual knob on the main gas valve is turned to the ON position. This valve is at the rear on the right side of the unit.
4. Turn on electrical service to the unit. The steamer will not operate without electrical power. Do not attempt to operate the unit during a power failure.

**NOTE:** The door **MUST** be closed for the main burner to work.

5. To turn the unit on, press the ON switch on the control panel.
6. When the steam generating reservoir has filled with water, the main burners will ignite automatically. Within 20 minutes or less the READY light will come on, indicating that the water has reached its standby

temperature. When the READY light is displayed, you may take any one of the following steps;

- a. Push TIMED and set the timer knob to the desired steaming time.
- b. Push MANUAL for continuous steaming.
- c. Push STOP to let the unit stay at ready condition.



**WARNING**  
**WHEN YOU OPEN THE DOOR, STAY AWAY**  
**FROM STEAM COMING OUT OF THE UNIT.**  
**STEAM CAN CAUSE BURNS.**

7. To shut down the unit, press the OFF switch. The steam generating reservoir will then fill with cold water and drain.
8. If the steamer operates as described, the unit is functioning correctly and ready for USE.

**NOTE:** For operation at high altitudes (2000 feet and above), please consult the Groen Foodservice Engineering Department.



# Operation

## A. Controls

Operator controls are on the front right of the unit.

The control panels have the following touch pads and indicator lights:

- The TIME display shows the remaining cooking time. It displays three dashes in MANUAL mode.
- The ON/OFF rocker switch gets the SmartSteam100 ready for use or shuts it off.
- The READY indicator light indicates the unit has achieved the ready temperature.
- Hour meter records cumulative hours of operation.
- The FAULT display shows the current fault.

### The push button operations:

1. In the STOP mode the steam generator stays at a low boil or ready temperature.
2. When the TIMED button is pushed, the TIMED light will illuminate and time can be set by turning the TIMER knob (cook time can be increased or decreased at any time by turning the timer knob). The unit steams until the timer counts down to zero and the temperature drops to ready. At that time the STOP light illuminates and a beeper sounds.
3. When the MANUAL button is pushed the unit steams continuously. The MANUAL light will stay illuminated.
4. CANCEL button should be pushed to stop beeping.

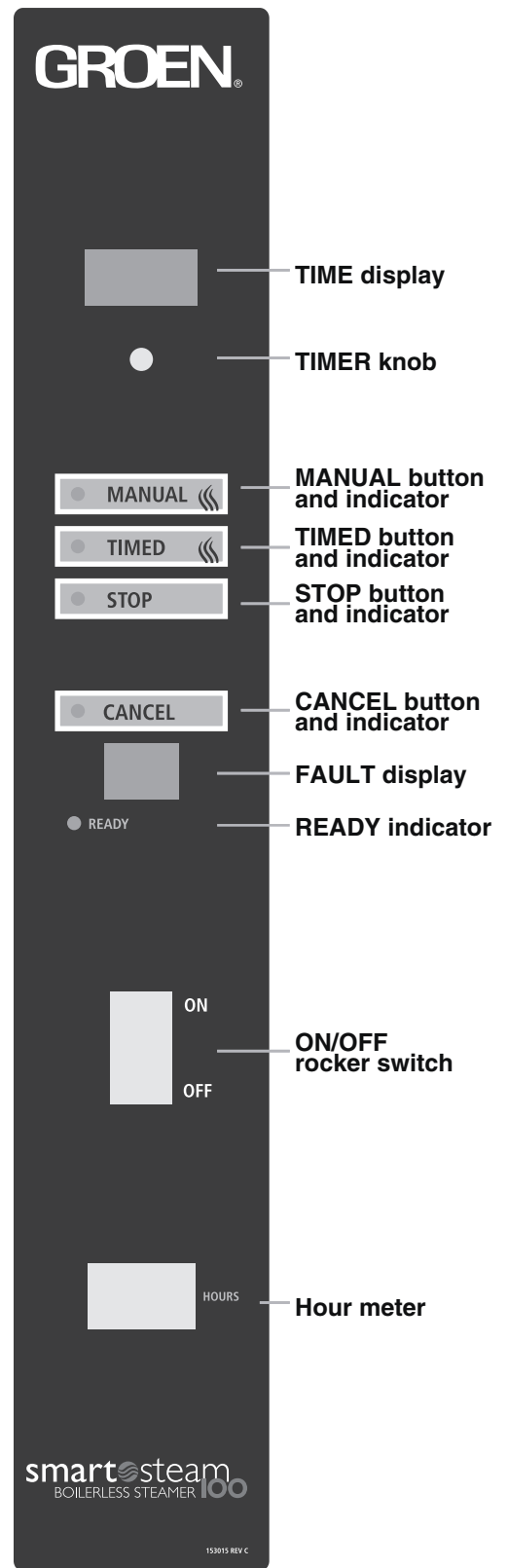

## B. Operating Procedure

1. Press the ON/OFF rocker to the ON position, (Fi\_) is displayed in the TIME display window. The steam generating reservoir will begin filling, displaying (Fi\_) and (Fi≡) as it fills. After initial fill the unit will begin draining displaying (Fi\_), refilling displaying (Fi≡), and then begin heating until the READY light comes on (about 15-20 minutes).

2. Load food into pans in uniform layers. Pans should be filled to about the same levels, and should not be mounded.
3. Open the door and slide the pans into the supports. If you will only be steaming one pan, put it in the middle position. Some foods will cause foam. When cooking foods that foam, such as shrimp, put an empty solid 2½" deep pan in the bottom slot of the pan racks.
4. Close the door. When the READY indicator is lit take one of the following steps:

If you want to steam the food for a certain length of time push the TIMED button and set the desired time with the TIMER knob. The timer will automatically run the steamer for the set time and then STOP. A beeper will sound. Push CANCEL to stop beeping.

If you want to steam continuously push the MANUAL button. The unit will continue steaming until stopped.

Push STOP to stop producing steam.

5. To remove pans from cavity open the door. Remove the pans from the steamer using hot pads or oven mitts to protect your hands from the hot pans.



**WARNING**  
**WHEN YOU OPEN THE DOOR, STAY AWAY FROM THE STEAM COMING OUT OF THE UNIT. THE STEAM CAN CAUSE BURNS.**

6. To shut off the unit press the ON/OFF rocker switch to OFF, (FL≡) will appear in the timer display. The steam generating reservoir will begin draining, displaying (Fi\_) and (Fi≡) as it drains, and refill to the high float twice and finally drain completely and turn off the unit.

NOTE: When filling or draining the steam generating reservoir (≡) will be displayed indicating the water level in the reservoir. ( ) reservoir is empty, (≡) low float is satisfied, (≡) high float is satisfied.

NOTE: If a large amount of shrimp is cooked in the SmartSteam100 foaming will occur because the steam lid actually gets so hot that the shrimp will cook on its surface and the shrimp proteins in the dripping will foam on the surface of the steam lid.

\* To avoid this use a catch pan to catch shrimp drippings and proteins to prevent foaming when cooking a large amount of shrimp.

———— High Float  
———— Low Float  
———— Empty

## Cleaning

To keep your SmartSteam100 Boilerless Steamer in proper working condition, use the following procedure to clean the unit. This regular cleaning will reduce the effort required to clean the steam generator and cavity.

### A. Suggested Supplies

1. Mild detergent
2. Stainless steel exterior cleaner Groen Spray DeGreaser (Part Number 140830WS)
3. Cloth or sponge
4. Brush with soft bristles
5. Spray bottle
6. Measuring cup
7. Nylon pad
8. Towels
9. Plastic disposable gloves
10. Funnel



### B. Procedure

1. Exterior Cleaning
  - a. Prepare a warm solution of the mild detergent as instructed by the supplier. Wet a cloth with this solution and wring it out. Use the moist cloth to clean the outside of the unit. Do not allow freely running liquid to touch the controls, the control panel, any electrical part, or any louver on the rear panels.
  - b. To remove material which may be stuck to the unit, use a fiber brush or a plastic or rubber scraper with a detergent solution.
  - c. Stainless steel surfaces may be polished with a recognized stainless steel cleaner.
2. Interior Cleaning



Daily cleaning must be done in order to enhance the performance and prolong the life of your SmartSteam Boilerless Steamer.

**WARNING**  
**DISCONNECT THE POWER SUPPLY BEFORE CLEANING THE OUTSIDE OF THE STEAMER.**

**KEEP WATER AND CLEANING SOLUTIONS OUT OF CONTROLS AND ELECTRICAL COMPONENTS. NEVER HOSE OR STEAM CLEAN ANY PART OF THE UNIT.**

**AVOID CONTACT WITH ANY CLEANERS, DELIMING AGENT OR DEGREASER AS RECOMMENDED BY THE SUPPLIER. MANY ARE HARMFUL. READ THE WARNINGS AND FOLLOW THE DIRECTIONS!**

**EVEN WHEN THE UNIT HAS BEEN SHUT OFF, DON'T PUT HANDS OR TOOLS INTO THE COOKING CHAMBER UNTIL THE FAN HAS STOPPED TURNING.**

**DON'T OPERATE THE UNIT UNLESS THE REMOVABLE PARTITION HAS BEEN PUT BACK IN ITS PROPER LOCATION.**

**DON'T USE ANY CLEANING AGENT THAT CONTAINS ANY SULFAMIC AGENT OR ANY CHLORIDE, INCLUDING HYDROCHLORIC ACID (HCL). TO CHECK FOR CHLORIDE CONTENT SEE ANY MATERIAL SAFETY DATA SHEETS PROVIDED BY THE CLEANING AGENT MANUFACTURER.**

### IMPORTANT

**DO NOT USE ANY METAL MATERIAL (SUCH AS METAL SPONGES) OR METAL IMPLEMENTS (SUCH AS A SPOON, SCRAPER OR WIRE BRUSH) THAT MIGHT SCRATCH ANY STAINLESS STEEL SURFACE. SCRATCHES MAKE THE SURFACE HARD TO CLEAN AND PROVIDE PLACES FOR BACTERIA TO GROW. DO NOT USE STEEL WOOL, WHICH MAY LEAVE PARTICLES EMBEDDED IN THE SURFACE, WHICH COULD EVENTUALLY CAUSE CORROSION AND PITTING.**

**WARNING! ALLOW THE STEAMER TO COOL COMPLETELY BEFORE CLEANING. HOT SURFACES CAN CAUSE SEVERE BURNS.**

**CLEANING STEPS:**

**STEP 1** - Press OFF switch to turn steamer OFF and open steamer door.

**STEP 2** - CAUTION: allow the steamer to cool completely before cleaning.

**STEP 3** - Remove steam lid by grasping the two tabs located on the lid front and sliding pan forward.

**STEP 4** - Remove left pan rack by lifting rack up and pulling away from cavity wall.

**STEP 5** - Remove right fan shroud and rack assembly by lifting rack up and pulling away from cavity wall.

**STEP 6** - Clean steam lid, left pan rack and rack/shroud assembly to remove food soils. These three parts may be cleaned in a dishwasher.

**STEP 7** - Use a mild detergent to wipe down the entire steamer cavity to remove food and scale particles. Carefully clean float probes if food residue or loose scale is present. A thin layer of tightly bound scale is normal and will not affect steamer performance. If scale is excessive, then refer to deliming instructions below.

**STEP 8** - Remove drain strainer and clean thoroughly to remove any build-up of debris.

**STEP 9** - Replace pan racks and steam lid. Steamer is now cleaned and ready to use.

**FAILURE TO CLEAN THE STEAMER AS SPECIFIED COULD NEGATIVELY IMPACT THE PERFORMANCE OF THE STEAMER.**

FLOAT PROBE ORIENTATION

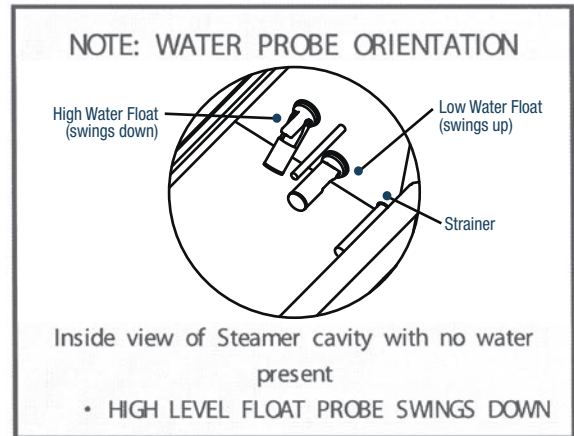

**DELIMING INSTRUCTIONS:**

- When using Groen Boilerless Water Filtration System use vinegar as a deliming agent.
- Groen approved delimer may be used to remove excessive scale build-up.

**STEP 1** - After following all cleaning steps 1 through 7 listed above, turn steamer on and allow water to enter steamer cavity.

**STEP 2** - Pour 1 cup of vinegar or delimer into steamer cavity and shut door.

**STEP 3** - Set steamer timer to 30 minutes and allow steam cleaning to occur.

**STEP 4** - After 30 minutes cleaning cycle is complete, turn steamer OFF and allow to cool completely.

**STEP 5** - Open steamer door and wipe down the entire steamer cavity to remove loosened scale particles. Carefully clean float probes if loose scale is present.

**STEP 6** - Replace pan racks and steam lid. Steamer is now cleaned and ready to use.

## Maintenance

The SmartSteam100 Boilerless Steamer is designed for minimum maintenance and no user adjustments should be necessary. Certain parts may need replacement after prolonged use. If there is a need for service, only Groen Authorized Service Agents should perform the work.

If steam or condensate is seen leaking from around the door, take the following steps:

1. Check the door gasket. Replace it if it is cracked or split.
2. Inspect the cooking chamber drain to be sure it is not blocked.
3. Adjust the door latch pin to allow for changes that might occur as the gasket ages.
  - a. Loosen the lock nut at the base of the latch pin, then turn the latch pin  $\frac{1}{4}$  turn clockwise, and tighten the lock nut.
  - b. After adjustment, run the unit to test for further steam leakage.
  - c. If there is still leakage, repeat the adjustment
  - d. Continue adjusting the pin clockwise until the door fits tightly enough to prevent leakage. The hinge may also be adjusted.

## Troubleshooting

Your Groen SmartSteam Boilerless Steamer is designed to operate smoothly and efficiently if properly maintained. However, the following is a list of checks to make in the event of a problem. Wiring diagrams are furnished inside the service panel. If an item on the check list is marked with (\*), it means that the work should be done by a Groen Authorized Service Agent.

SYMPTOM	WHO	WHAT TO CHECK
1. Fault Display 1 or 2	User	<ol style="list-style-type: none"> <li>a. Clean floats in unit / Check float probe orientation</li> <li>b. Be sure water supply is adequate to run steamer(s) during normal operation.</li> </ol>
2. No power.	User	<ol style="list-style-type: none"> <li>a. Check wall circuit breaker.</li> <li>b. Disconnect power, then check fuses on inside of steamer. *</li> <li>c. Call service technician.</li> </ol>
3. Unit overfills with water at start up.	User	<ol style="list-style-type: none"> <li>a. Clean floats in unit / Check float probe orientation.</li> <li>b. Clean drain strainer.</li> <li>c. Call service technician.</li> </ol>
4. Steamer does not fill with water.	User	<ol style="list-style-type: none"> <li>a. Is the ON switch depressed?</li> <li>b. Is the water supply connected?</li> <li>c. Is the water turned on?</li> <li>d. Is the water supply hose kinked or obstructed?</li> <li>e. Check for low water pressure (less than 30 PSI) or low water flow (less than 1.5 gpm).</li> <li>f. Is the screen at the water connection clogged?</li> </ol>
5. "Door" Shown in Time Display Window	User	<ol style="list-style-type: none"> <li>a. Is the steamer door securely closed?</li> </ol>
6. No steam.	User	<ol style="list-style-type: none"> <li>a. Is the ON switch depressed?</li> <li>b. Is the water supply connected?</li> <li>c. Is the water turned on?</li> <li>d. Is steamer door completely closed?</li> </ol>
7. Fault Display 7	User	<ol style="list-style-type: none"> <li>a. The component cooling fan may not be operating. The display may come on for several minutes during normal operation. If it stays on for more than 30 minutes, call service technician. Unit may be used for cooking, while waiting for service.</li> </ol>

8. Any unusual operation.	User	a. Press OFF switch to turn steamer off. Momentarily turn circuit breaker off and then on or unplug from power. Turn unit back on.
9. Door pops open.	User	a. Ensure drain and vent are not plugged. No more than two units should be attached to a single drain line. b. Check door pin adjustment per above. c. Call service technician.
10. Fault Display 6	User	a. Wait 30 minutes for unit to cool down. b. Call service technician.

# PARTS LIST - SSB - 3G / 5G / 10GF

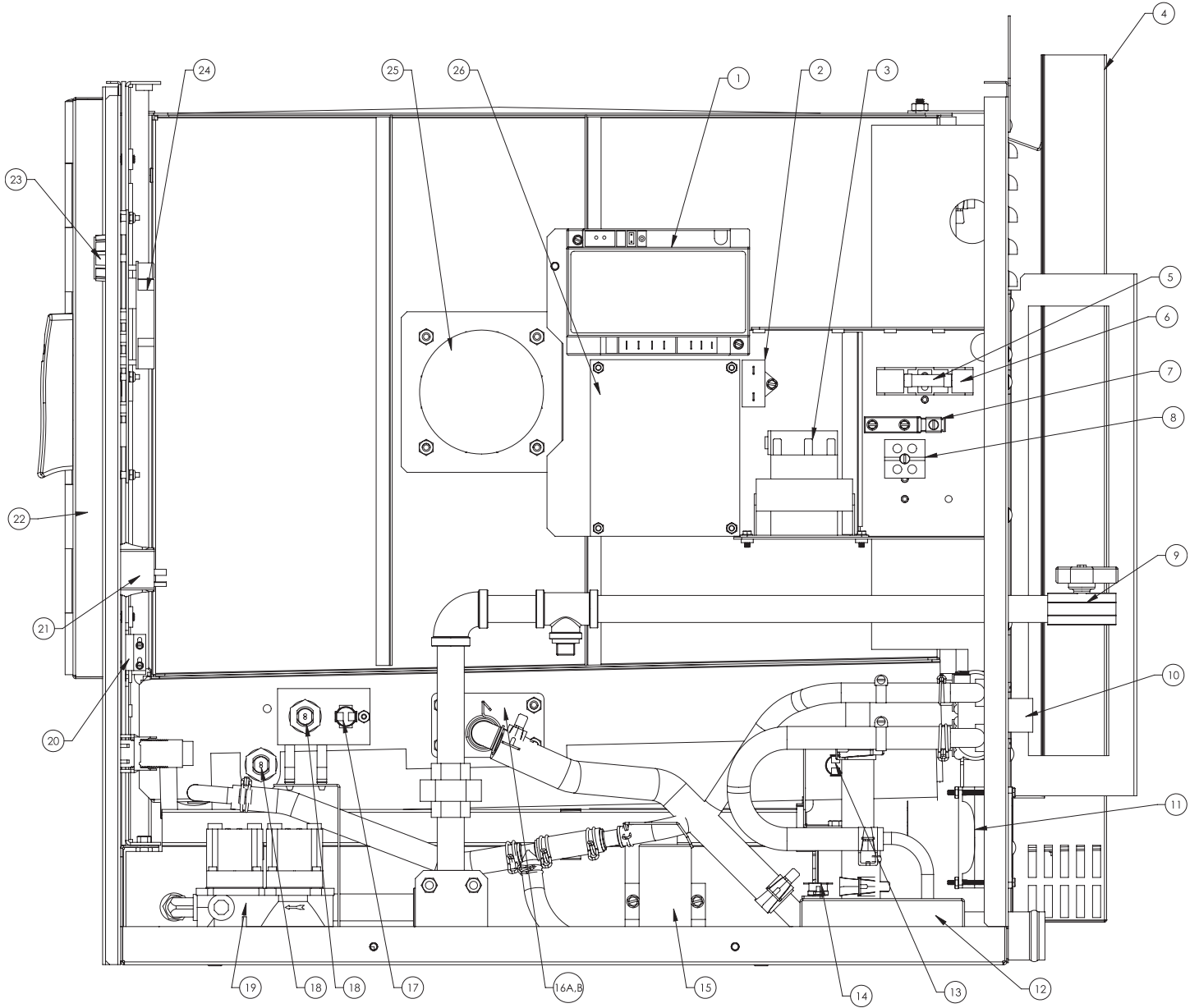

# PARTS LIST - SSB - 3G / 5G / 10GF

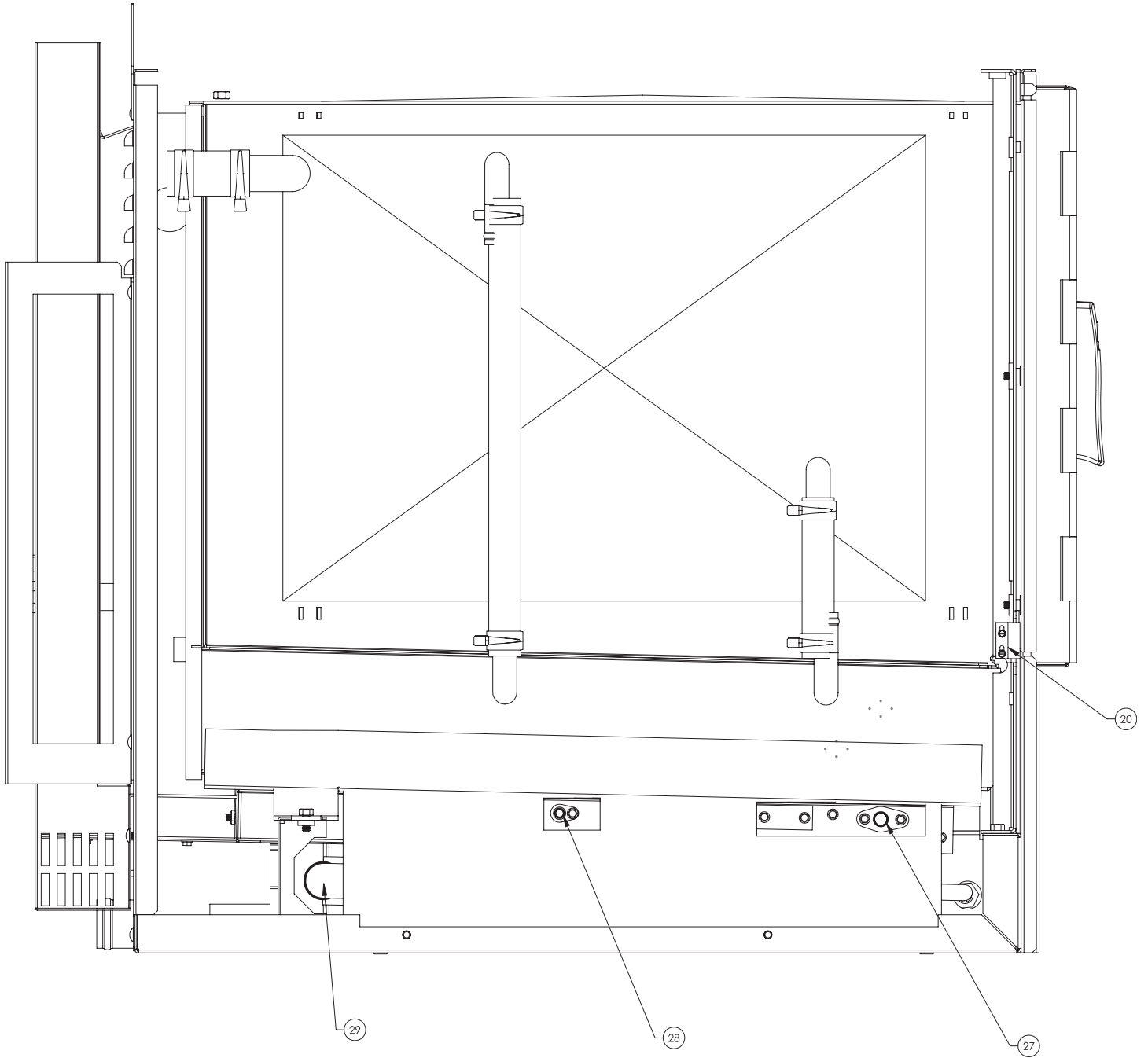



# PARTS LIST - SSB - 3G / 5G / 10GF

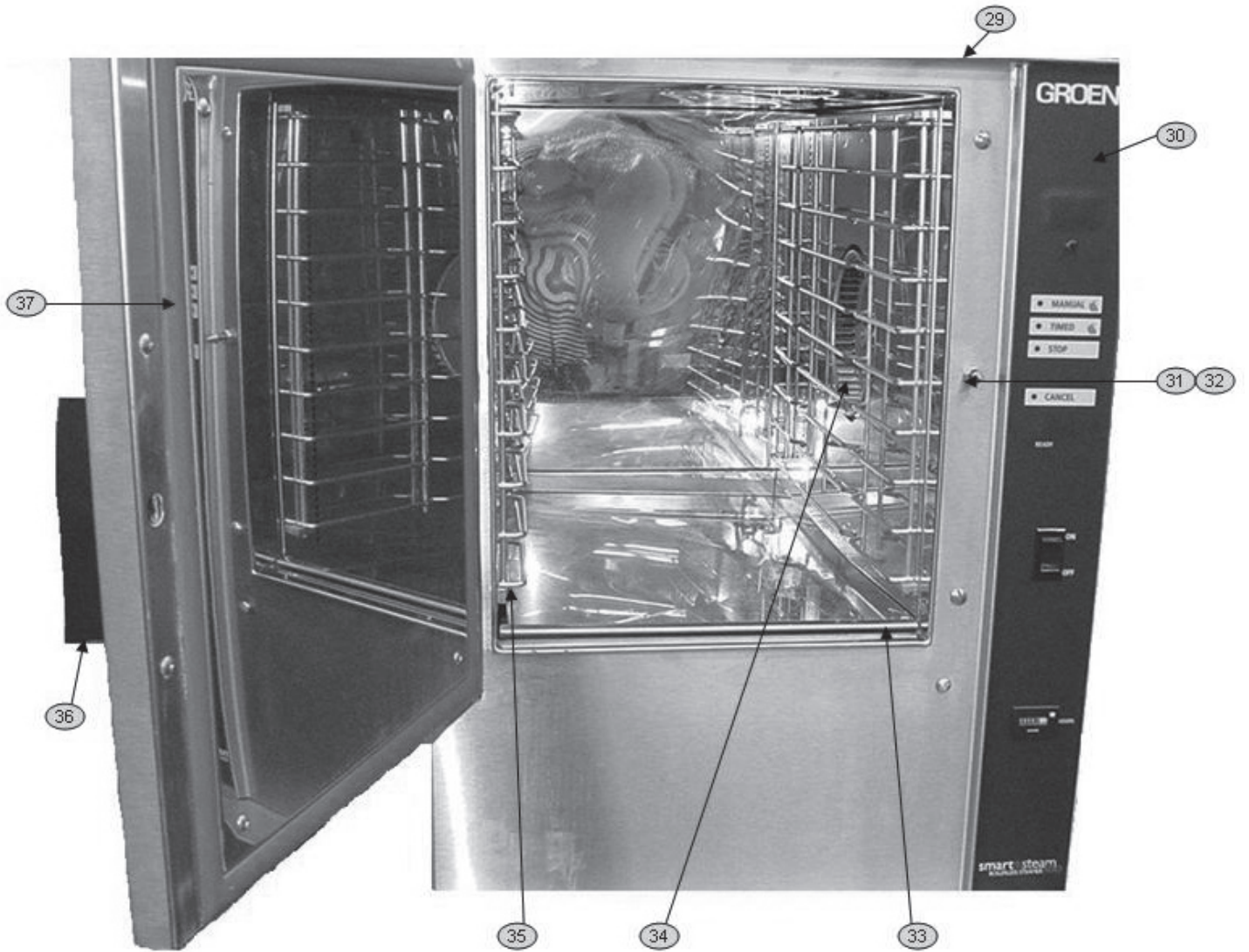

## PARTS LIST - SSB - 3G / 5G / 10GF

To order parts, contact your Groen Authorized Service Agent. Supply the model designation, serial number, part description, part number, quantity, and when applicable, voltage and phase.

Key	Description	Part No.	Key	Description	Part No.
1	Ignition Module	140184	30	Top Panel (3G / 5G)	150637
2	Capacitor, 6MF	096812		Top Panel (10G)	149444
3	Transformer 120v Primary/ 24v secondary, 75VA	121715	31	Front Panel Overlay (3G)	153015
4	Fluestack, Single (3G)	143957		Front Panel Overlay (5G/10G)	153472
	Fluestack, Single (5G)	141991	32	Door Latch Pin	078914
	Fluestack, Single (10G)	145254	33	Door Pin Lock Nut	003823
	Fluestack, Double (3G)	143965	34	Steam Lid (3G/5G)	149299
	Fluestack, Double (5G)	143567		Steam Lid (10G)	149452
	Fluestack, Double (10G)	145531	35	Cavity Fan	096790
5	Fuseholder	077840	36	Left Pan Rack (3G)	149883
6	Fuse	119823		Left Pan Rack (5G)	149872
7	Ground Terminal	106412		Left Pan Rack (10G)	145642
8	Terminal Block	003887	37	Door Handle	129723
9	Main Gas Valve	098443	38	Door Gasket (3G)	124849
10	Water Valve	071235		Door Gasket (5G)	125907
11	Muffin Fan	153505		Door Gasket (10G)	143879
12	Drain Box (3G/5G)	150659	x	Motor Shaft Seal	096868
	Drain Box (10G)	150661	x	Blower Cover (3G)	149387
13	Hi-Limit	144484		Blower Cover (5G)	149313
14	Thermostat (drain box)	145248		Blower Cover (10G)	149451
15	Drain Valve	071234	x	Right Pan Rack (3G)	141571
16A	Condensate Cup	150628		Right Pan Rack (5G)	140157
16B	Gasket, condensate cup	142613		Right Pan Rack (10G)	145721
17	Ready Thermostat	147285	x	Drip Tray (3G/5G)	094151
18	Water Level Probe (Serial Number MSA and MSB)	142689		Drip Tray (10G)	145520
	Float Probe (Serial Number MSC and Following)	149880	x	Left Side Panel (3G)	149229
19	Gas Valve	098458		Left Side Panel (5G)	149233
20	Door Switch	096857		Left Side Panel (10G)	149446
21	Power Switch	160920	x	Right Side Panel (3G)	149231
22	Door Assembly, Complete (3G)	130858		Right Side Panel (5G)	149235
	Door Assembly, Complete (5G)	125922		Right Side Panel (10G)	149448
	Door Assembly, Complete (10G)	143874	x	Flow Reducer, Condensate	147371
23	Knob	160921	x	Flow Reducer, Fill	144481
24	Control Board	160648	x	Harness, Control To Relay Board SSB	160885
25	Motor Assembly	146880	x	Harness, SSB-G Rear	160883
26	Relay Board	160649	x	Harness, SSB-G Low Voltage	160881
27	Ignitor (3G/5G)	143559	x	Harness, SSB-G Ignition	153339
	Ignitor (10G)	149009	x	Harness, SSB-G Forward	153338
28	Flame Sense	143673	x	Harness, Steamer High Voltage	160874
29	Burner (3G/5G)	143976	x	Jumper, Voltage Select 120VAC	123123
	Burner (10G)	145074	x	Harness, Jumper	123125

x- Item not depicted/called out in drawing

# WIRING DIAGRAM - SSB - 3G / 5G / 10GF

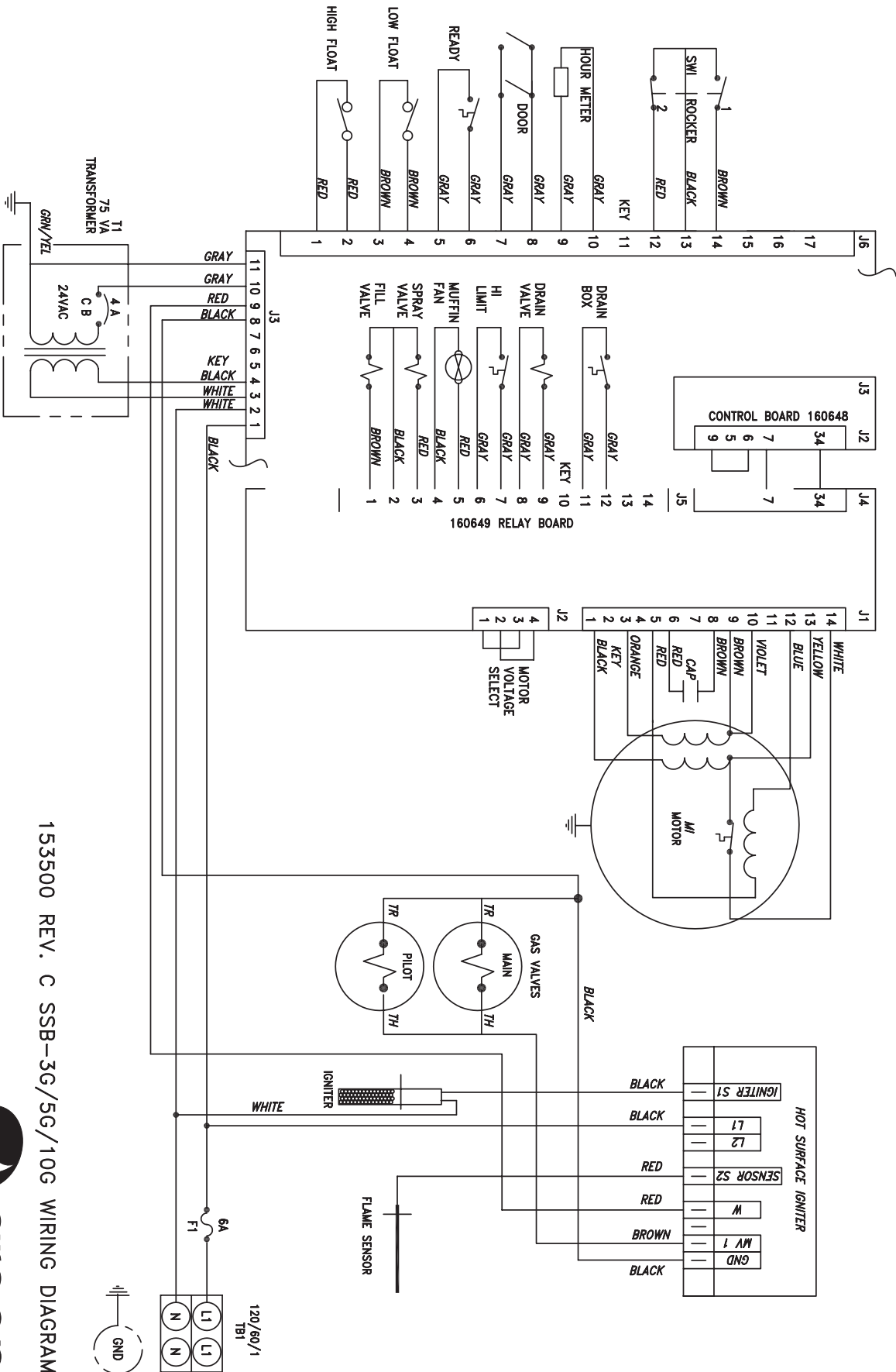

153500 REV. C SSB-3G/5G/10G WIRING DIAGRAM



## Service Log

Model No. \_\_\_\_\_ Purchased From \_\_\_\_\_  
Serial No. \_\_\_\_\_ Location \_\_\_\_\_  
Date Purchased \_\_\_\_\_ Date Installed \_\_\_\_\_  
Purchase Order No. \_\_\_\_\_ For Service Call \_\_\_\_\_

Date	Maintenance Performed	Performed by

## **GROEN LIMITED WARRANTY TO COMMERCIAL PURCHASE\* (U.S. & Canadian Sales Only)**

Groen warrants to original commercial purchaser/users that foodservice equipment manufactured by Groen ("Groen Equipment") other than CapKold foodservice equipment, shall be free from defects in material and workmanship for (i) 2000 actual operating hours (provided that such equipment has a device that has recorded actual operating hours since the installation of such equipment), (ii) twelve (12) months from the date of installation or (iii) fifteen (15) months from the date of shipment from Groen, whichever first occurs (the "Warranty Period"), in accordance with the following terms and conditions:

**I.** This warranty is limited to replacement parts and related labor for Groen Equipment located at its original place of installation in the United States and Canada.

**II.** Damage to Groen Equipment that occurs during shipment must be reported to the carrier and is not covered under this warranty. The reporting of any damage during shipment is the sole responsibility of the commercial purchaser/user of such Groen Equipment.

**III.** For Groen Convection Combo™ Steamer-Ovens, HyPerSteam™ Convection Steamers and HyPlus™ Pressureless Steamers, Groen further warrants to the original commercial purchaser/users of such Groen Equipment that the atmospheric steam generators or boilers contained in such Groen Equipment shall be free from defects in material and workmanship for (i) 4000 actual operating hours (provided that such equipment has a device that has recorded actual operating hours since the installation of such equipment), (ii) twenty-four (24) months from the date of installation or (iii) twenty-seven (27) months from date of shipment from Groen, whichever first occurs, provided that: (a) the original purchaser/user shall have also purchased and installed a Groen PureSteam™ Water Treatment System for use in connection with such Groen Convection Combo Steamer-Oven, HyPerSteam Convection Steamer or HyPlus Pressureless Steamer on or before the date such Groen Equipment was installed, (b) the original purchaser/user has continuously used such Water Treatment System in connection with such Groen Equipment from the date of installation, and (c) the commercial purchaser/user shall have maintained such Water Treatment System in accordance with the maintenance and filter cartridge replacement recommendations of Groen, and otherwise maintained such Oven or Steamer in accordance with all other operational and maintenance recommendations of Groen.

**IV.** For Groen SmartSteam100™ Boilerless Steamers and Vortex100™ Connectionless Steamers, Groen further warrants to the original commercial purchaser/users of SmartSteam™ Boilerless Steamers and Vortex™ Connectionless Steamers shall be free from defects in material and workmanship for (i) 4000 actual operating hours (provided that such equipment has a device that has recorded actual operating hours since the installation of such equipment), (ii) twenty-four (24) months from the date of installation or (iii) twenty-seven (27) months from the date of shipment from Groen, whichever first occurs. This warrants Groen Vortex100 Connectionless Steamers that were shipped after March 15, 2004, and SmartSteam100 Boilerless Steamers that were shipped after May 1, 2003.

**V.** Groen further warrants to the original commercial purchaser/users of Groen Convection Combo Steamer-Ovens that the electronic relay and control board contained in such Groen Convection Combo Steamer-Oven shall be free from defects in material and workmanship for (i) 4000 actual operating hours (provided that such equipment has a device that has recorded actual operating hours since the installation of such equipment), (ii) twenty-four (24) months from the date of installation or (iii) twenty-seven (27) months from the date of shipment from Groen, whichever first occurs.

**VI.** During the Warranty Period, Groen, directly or through its authorized service representative, will either repair or replace, at Groen's sole election, any Groen Equipment determined by Groen to have a defect in material or workmanship. As to any such warranty service during the Warranty Period, Groen will be responsible for related reasonable labor and portal to portal transportation expenses (time & mileage) incurred within the United States and Canada.

**VII.** This warranty does not cover boiler maintenance, calibration, periodic adjustments as specified in operating instructions or manuals, consumable parts (such as scraper blades, gaskets, packing, etc.), and labor costs incurred for removal of adjacent equipment or objects to gain access to Groen Equipment. This warranty does not cover defects caused by improper installation, abuse, careless operation, or improper maintenance of Groen Equipment. This warranty does not cover damage to Groen Equipment caused by poor water quality or improper boiler maintenance.

**VIII.** THIS WARRANTY IS EXCLUSIVE AND IS IN LIEU OF ALL OTHER WARRANTIES, EXPRESSED OR IMPLIED, INCLUDING ANY IMPLIED WARRANTY OF MERCHANTABILITY OR FITNESS FOR A PARTICULAR PURPOSE, EACH OF WHICH IS HEREBY EXPRESSLY DISCLAIMED. THE REMEDIES DESCRIBED ABOVE ARE EXCLUSIVE AND IN NO EVENT SHALL GROEN BE LIABLE FOR SPECIAL, CONSEQUENTIAL, OR INCIDENTAL DAMAGES FOR THE BREACH OR DELAY IN PERFORMANCE OF THIS WARRANTY.

**IX.** Groen Equipment is for commercial use only. If sold as a component of another (O.E.M.) manufacturer's equipment, or if used as a consumer product, such Equipment is sold AS IS and without any warranty.

#### **Cost of Extended Coverage.**

Limited Extended Warranty Coverage is available on all standard Groen Equipment (other than CapKold foodservice equipment) covered by the above Groen Limited Warranty. Commercial purchasers/users of Groen Equipment may elect to extend the standard limited warranty to cover parts, labor and portal to portal transportation costs (time and mileage) for an additional (i) 2000 actual operating hours, or (ii) twelve (12) month period, or for an additional (i) 4000 actual operating hours, or (ii) twenty four (24) month period, whichever first occurs, in addition to the time period of the standard limited warranty described above. Limited Extended Warranty Coverage is not available to extend the supplemental limited warranty for: (a) atmospheric steam generators or boilers contained in Groen Convection Combo Steamer-Ovens, HyPerSteam Convection Steamers and HyPlus Pressureless Steamers, or (b) electronic relay and control boards contained in Groen Convection Combo Steamer-Ovens, or (c) Groen SmartSteam100 Boilerless Steamers, or (d) Vortex100 Connectionless Steamers

Five percent (5.0%) of the LIST PRICE of the Groen Equipment to be covered by the Limited Extended Warranty for each additional twelve (12) months of limited extended warranty coverage. The five percent (5.0%) of the LIST PRICE charge will be the net invoice amount for each year of Limited Extended Warranty Coverage purchased.

#### **Conditions of Coverage**

**(1)** Limited Extended Warranty Coverage must be purchased at the time the Groen Equipment to be covered is purchased.

**(2)** All conditions and limitations on the Standard Limited Warranty Coverage apply to the Limited Extended Warranty Coverage. See above for details of conditions and limitations on the Standard Warranty Coverage.

Covers Groen Equipment (other than CapKold foodservice equipment and Vortex Connectionless Steamers) ordered after September 11, 2001.

## NOTES:



1055 Mendell Davis Drive • Jackson MS 39272  
888-994-7636 • 601-372-3903 • Fax 888-864-7636  
[groen.com](http://groen.com)