

# OWNER'S MANUAL

## MODEL HST13 – AUTOTOAST™ VERTICAL TOASTER



Supplier Name: **MARSHALL AIR SYSTEMS, INC.**  
Address: 419 Peachtree Drive South  
Charlotte, NC 28217

Serial#: \_\_\_\_\_  
Date Received: \_\_\_\_\_  
Date Installed: \_\_\_\_\_  
Telephone #: 704-525-6230  
Fax #: 704-525-6229  
Service Referral# 800-722-3474  
Local Service Name: \_\_\_\_\_  
Local Service #: \_\_\_\_\_  
Conveyor Speed \_\_\_\_\_  
Setting: \_\_\_\_\_

### PRODUCT DESCRIPTION

The Marshall High Speed Vertical Toaster produces a grilled effect on the cut side of the sandwich buns. The buns are inserted at the top of the unit and are pressed against a heated platen surface, which is covered by a replaceable toaster platen sheet. The spacing between the heated grill and the conveyor is adjustable to accommodate different thickness of buns. The buns are discharged onto a product slide at the bottom of the unit. Toaster Models CH7, CH7B, have variable speed motor controls. Models CH7C, CH7D have single speed motors. Toast time on the CH7C toaster is 8 seconds heel, and 11 seconds crown. The CH7D toaster has a toast time of 23 seconds on both the crown and heel. The CH7F toaster has a toast time of 9 seconds on both the crown and heel. The CH7F-15 toaster has a toast time of 15 seconds on both the crown and heel. The CH7G toaster has a toast time of 3.5 minutes. The CH7H has a 60 second toast time. Additionally, the heat settings are preset in factory, which eliminates unauthorized tampering. The flexibility of this toaster is unmatched allowing operations to produce the hottest buns in the shortest time.

### GENERAL SPECIFICATIONS

Height: 23.250"  
Width: 19.875"  
Depth: Model CH7B-12", CH7-15.250"  
Model CH7C-12", CH7D-12", CH7F-12",  
CH7G-12", CH7H-12"  
Electrical: 208V Single Phase 18.5 Amps  
240V Single Phase 21.0 Amps  
Power Cord: 6 ft. 3 wire including ground, with NEMA  
L6-20Pplug (208V) (CH7C Models L6-  
30P)(CH7H Models NEMA 6-20P)  
(Plug furnished by others on  
International units) (CH7CINTLCE  
NEMA L6-30P)  
Weight: 116 lbs.  
Listing: ETL and NSF

### FOR YOUR SAFETY

**DO NOT STORE OR USE GASOLINE OR OTHER FLAMMABLE VAPORS OR LIQUIDS IN THE VICINITY OF THIS OR ANY OTHER APPLIANCE.**

**WARNING: IMPROPER INSTALLATION, ADJUSTMENT, ALTERATION, OR MAINTENANCE CAN CAUSE PROPERTY DAMAGE, INJURY OR DEATH. READ THE INSTALLATION, OPERATION AND MAINTENANCE INSTRUCTIONS THOROUGHLY BEFORE INSTALLING OR SERVICING THIS EQUIPMENT.**

**KEEP THIS MANUAL IN A SAFE PLACE AND RETAIN FOR FUTURE USE.**



# OWNER'S MANUAL

## MODEL HST13 – AUTOTOAST™ VERTICAL TOASTER



### TABLE OF CONTENTS

PRE INSTALLATION.....	1
INSTALLATION .....	1-2
OPERATION (UNITS WITH LED CONTROL).....	2
OPERATION (UNITS WITH HEAT SWITCH AND CONVEYOR SWITCH).....	3
PREVENTIVE MAINTENANCE.....	3-4
TROUBLESHOOTING GUIDE .....	4-8
REPLACEMENT PARTS.....	8-9

### ILLUSTRATIONS

OVERALL DIMENSIONS .....	FIGURE 1, 2
HANG-ON PARTS S/N 0598 AND BEFORE .....	FIGURE 3
HANG-ON PARTS S/N 0599 AND AFTER .....	FIGURE 4
SWITCHES AND TOASTER PLATEN SHEET .....	FIGURE 5
BELT TENSION PARTS AND ADJUSTMENT MECHANISM.....	FIGURE 6
INTERNAL PARTS AND DRIVE COMPONENTS .....	FIGURE 7
ADJUSTMENT LEVER OPERATION.....	FIGURE 8
BELT REMOVAL INSTRUCTIONS .....	FIGURE 9
NON-GUIDED BELT INSTALLATION INSTRUCTIONS.....	FIGURE 10
NON-GUIDED BELT INSTALLATION INSTRUCTIONS.....	FIGURE 11
GUIDED BELT REMOVAL AND INSTALLATION INSTRUCTIONS.....	FIGURE 12
CONTROL CABINET ACCESS INSTRUCTIONS.....	FIGURE 13
WEEKLY BELT CLEANING INSTRUCTIONS (150986).....	FIGURE 14

### **SCHEMATICS FOR UNITS S/N 0929 AND AFTER (UNITS W/LED CONTROL)**

WIRING SCHEMATIC (208V, 60HZ, 1PH) VARIABLE SPEED.....	DWG #143851
WIRING SCHEMATIC (208V, 60HZ, 1PH) SINGLE SPEED .....	DWG #143856



**ILLUSTRATIONS (CONTINUED)**

WIRING SCHEMATIC (240V, 60HZ, 1PH) DOMESTIC VARIABLE SPEED.....DWG #143857  
WIRING SCHEMATIC (240V, 50/60Hz, 1 PH) SINGLE SPEED.....DWG #142426  
WIRING SCHEMATIC (220V, 50/60Hz, 1PH) SINGLE SPEED(ECM CONTROL) .....DWG #144562  
WIRING SCHEMATIC (220V, 50/60Hz, 1PH) SINGLE SPEED (LED CONTROL) .....DWG #144577  
WIRING SCHEMATIC (220-240V, 50/60Hz, 1PH) VARIABLE SPEED (LED CONTROL).....DWG #145737

**SCHEMATICS FOR UNITS S/N 0928 AND BEFORE**

WIRING SCHEMATIC (208V, 50/60Hz, 1PH) .....DWG #135169  
WIRING SCHEMATIC (240V, 50/60Hz, 1PH) CE .....DWG #135817  
WIRING SCHEMATIC (240V, 50/60Hz, 1PH) DOMESTIC .....DWG #143180  
WIRING SCHEMATIC (240V, 50/60Hz, 1PH) .....DWG #138828  
WIRING SCHEMATIC (208V, 50/60Hz, 1PH)SINGLE SPEED.....DWG #141334  
WIRING SCHEMATIC (208V, 50/60Hz, 1PH)VARIABLE SPEED..... DWG #145294

# OWNER'S MANUAL

## MODEL HST13 – AUTOTOAST™ VERTICAL TOASTER



### PRE-INSTALLATION

1. The toaster is packaged to minimize the risk of shipping damage. Immediately upon receipt, make certain to inspect the unit for damage. **FILE ALL CLAIMS WITH THE FREIGHT CARRIER.**
2. Unpack unit and remove all protective paper or plastic from metal parts. **FILE ANY CONCEALED DAMAGE CLAIMS WITH THE FREIGHT CARRIER.**
3. This toaster is shipped wired and ready to plug into a grounded NEMA L6-20R amp receptacle. (208 Volt Single Phase, 3 wire including the ground circuit). Check receptacle for proper voltage and phase. Units which are 240V single phase international are shipped with no electrical plug.

### INSTALLATION

1. It is necessary to seal bottom of toaster to the countertop using NSF listed silicone sealant.
2. Check that the two lift off side covers are in place on the toaster **AND THE LEFT COVER IS SECURED WITH A SCREW AT THE BOTTOM.**
3. Check that the toaster platen sheet is installed over the contact platen. The toaster platen sheet is installed from the top of the unit by lightly creasing it at the center, and directly hanging it on the center platen. **USE ONLY MARSHALL APPROVED PLATEN SHEETS OR TOASTER WARRANTY IS VOID.**
4. Install the bun guide assembly on the toaster. (Figure 4)
5. Connect the toaster to the power supply.
6. Turn on the power switch and check for free movement of the two conveyor belts. If unit is equipped with LED control, display will read "Lo."
7. Unit is ready to used in approximately 15 minutes. LED control will display "Rdy."
8. After warm up, drop buns into the toaster at the top of the unit. For proper operation, insert heels on the side of the toaster marked "Heel", and crown on the opposite side. **THE CUT SIDES OF THE HEEL AND CROWN MUST FACE EACH OTHER. DO NOT USE PRE-BUTTERED BUNS WITH THIS TOASTER.**
9. The toasted heel and crown will drop down onto the product slide together. Check the appearance of the toasted buns.
10. Adjust the gap settings using the two levers inside the right panel. (See Figure 8). The levers are labeled "HEEL" gap and "CROWN" gap. To adjust the gap, loosen the black adjustment knob (Figure 8), several turns to disengage the threaded rod from the locator holes. Turn the lever to the desired position and retighten the black knob so that the threaded rod engages in one of the locator holes.
11. The speed control is located behind the left side cover of the CH7, CH7B toasters only. **DISCONNECT (UNPLUG) THE POWER BEFORE OPENING THE SIDE COVER.** The speed control can be adjusted to control the conveyor belt speed to lighten and darken the toasted product. The toaster is shipped with the speed control set for a twelve-second toast. Models

# OWNER'S MANUAL

## MODEL HST13 – AUTOTOAST™ VERTICAL TOASTER



CH7C and CH7D have a single speed motor. CH7C models have a toast time of a 8 seconds heel and 11 seconds crown. CH7D models have a speed of 23 seconds both crown and heel. CH7F has a 9 second toast time both crown and heel. The CH7F-15 has a 15 second toast time. CH7G models have a 3.5 minute toast time both crown and heel.

12. Test at least 3 buns before putting the toaster into service. Uniform surface toasting and bun temperature are achieved when the gap described in step 10 is set correctly.

### OPERATION (UNITS WITH LED CONTROL)

1. The toaster is operated by pressing and releasing the "I/O" Button of the control. "Lo" will be displayed.
2. The display of the control will show "Rdy" once the toaster is up to temperature. (Approximately 15 minutes.)
3. For proper operation, insert heels on the side of the toaster marked "HEEL", and crowns on the opposite side.
4. To turn off, press and hold the "I/O" Button. "Hi" will be displayed which means unit is still too hot to remove any parts. Once the toaster has cooled (approximately 30 minutes), the display will show "Off."
5. The LED Control will indicate important information:
  - A. Press and release either the Crown or the Booster Button, the pre-programmed temperature settings will flash. This will display for 5 seconds or until another button is pressed.
  - B. Press and hold either the Crown or the Booster Button for 3 seconds, the actual platen temperatures will be displayed. This will display until another button is pressed.
6. Definitions of various displays:

"Off"	Unit is off and not operating.
"Lo"	Heater platens have not reached programmed set temperature.
"Rdy"	Unit has reached programmed set temperature and is ready to toast.
"Hi"	Unit is off and too hot to touch most removeable parts.
"AL1"	This is an alarm message that indicates the Center Platen Probe is disconnected or defective.
"AL2"	This is an alarm message that indicates the Booster Platen Probe is disconnected or defective.
"AL3"	This is an alarm message that indicates the Center Platen is too hot. Normally this means the relay has failed. Unit shuts off.
"AL4"	This is an alarm message that indicates the Booster Platen is too hot. Normally this means the relay has failed. Unit shuts off.

# OWNER'S MANUAL

## MODEL HST13 – AUTOTOAST™ VERTICAL TOASTER



### OPERATION (UNITS WITH HEAT SWITCH AND CONVEYOR SWITCH)

1. The toaster is operated by turning on the power switch and then the heat switch.
2. Allow the toaster to warm up for approximately 15 minutes before toasting buns.
3. For proper operation, insert heels on the side of the toaster marked "HEEL", and crowns on the opposite side.
4. Turn unit off at the end of the day.
5. Toaster Platen Sheet General Information:
  - A. The toaster is not designed for use with buttered buns.
  - B. The life of the Toaster Platen Sheet depends on usage and cleaning.
  - C. If the sheet is turning white, the black pigment is fading out of the sheet and does not mandate sheet replacement.
  - D. When buns no longer feed through the machine but instead are damaged or torn, the toaster platen sheet should be replaced. Replace **ONLY** with Marshall toaster platen sheet.
  - E. To obtain maximum life, rotate the sheet daily so the "HEEL" side is opposite from the day before.
  - F. **USE ONLY MARSHALL APPROVED PLATEN SHEETS OR TOASTER WARRANTY IS VOID.**

**CAUTION: DO NOT REMOVE THE CONTROL PANEL COVER WITHOUT FIRST TURNING OFF THE TOASTER AND UNPLUGGING THE TOASTER.**

### PREVENTIVE MAINTENANCE

#### DAILY:

1. Carefully remove the toaster platen sheet (Figure 5), lay it on a flat surface, and wipe with a soft cloth or towel and clean with soap and water. Use **ONLY** enough water to make the cloth damp. **DO NOT USE ABRASIVES ON THE TOASTER PLATEN SHEET.**
2. Rotate toaster platen sheet so the "HEEL" side is on the "CROWN" side, opposite than the day before.
3. Re-install all parts after drying.

#### WEEKLY:

1. Turn toaster off and unplug power cord from wall receptacle.
2. Perform daily maintenance.

# OWNER'S MANUAL

## MODEL HST13 – AUTOTOAST™ VERTICAL TOASTER



3. Remove the front and back covers (Figure 3,4), by lifting these covers off the toaster. Clean these covers with soap and water. Wipe the exposed metal parts with a damp soft cloth or towel.
4. Reconnect the power cord.
5. Clean belts according to the Belt Cleaning Procedures below. Do not scrub belts with abrasive material.
6. Install the front and rear covers.

### WEEKLY BELT CLEANING INSTRUCTIONS

**NOTE: TOASTER BELTS MUST BE CLEANED WHILE TOASTER IS AT OPERATING TEMPERATURE.**

Supplies Needed:      Cleaning Agent: Scotch-Brite™ Quick Clean Griddle Liquid #700-40.  
Contact a Marshall parts distributor or your restaurant supplies dealer to get these products.

   Cleaning Pad: Scotch-Brite™ All Purpose Scouring Pad #9488R.  
Contact a Marshall parts distributor or your restaurant supplies dealer to get these products

**SEE FIGURE #14 FOR BELT CLEANING INSTRUCTIONS.**

### MONTHLY:

1. Perform Daily and Weekly Maintenance.
2. Replace any worn out toaster platen sheets or conveyor belts with Marshall parts. **USE ONLY MARSHALL APPROVED PLATEN SHEETS OR TOASTER WARRANTY IS VOID.**

### QUARTERLY:

1. Inspect motor brushes on variable speed models. If  $\frac{1}{4}$ " in length or less, replace with new.
2. Lubricate the drive chain with drops of any grade motor or machine oil.

### TROUBLE SHOOTING GUIDE

**NOTE: SERVICE MUST BE PERFORMED BY A QUALIFIED SERVICE COMPANY. THE TERM "QUALIFIED SERVICE COMPANY" MEANS ANY INDIVIDUAL, FIRM, CORPORATION OR COMPANY WHICH IS EITHER ENGAGED IN AND IS RESPONSIBLE FOR THE INSTALLATION OR REPLACEMENT OF ELECTRICAL COMPONENTS, OR THE CONNECTION, INSTALLATION OR REPAIR OF ELECTRICAL APPLIANCES, WHO IS EXPERIENCED IN SUCH WORK, FAMILIAR WITH ALL PRECAUTIONS REQUIRED, AND HAS COMPLIED WITH ALL THE REQUIREMENTS OF THE AUTHORITY HAVING JURISDICTION.**



# OWNER'S MANUAL

## MODEL HST13 – AUTOTOAST™ VERTICAL TOASTER



**WARNING:** INSPECTION, TESTING, AND REPAIR OF ELECTRICAL EQUIPMENT SHOULD BE PERFORMED BY QUALIFIED SERVICE PERSONNEL. THE UNIT SHOULD BE UNPLUGGED WHEN SERVICING, EXCEPT WHEN ELECTRICAL TESTS ARE REQUIRED.

**DANGER:** USE EXTREME CARE DURING ELECTRICAL CIRCUIT TESTS. LIVE CIRCUITS WILL BE EXPOSED. WHERE TESTING INDICATES "WITH POWER OFF", BE SURE THAT THE CONVEYOR AND HEAT SWITCHES ARE OFF AND TOASTER IS UNPLUGGED.

### PROBLEM:

#### 1. No heat and conveyor belts do not move.

### SOLUTION:

- A. Check that toaster is plugged in. Check condition of power cord and plug.
- B. Check that conveyor power switch is on.
- C. Check circuit breaker in main breaker panel. Reset if necessary.
- D. Check that there is power at receptacle. Verify voltage is correct based upon the voltage listed on the toaster nameplate.
- E. Verify voltage is flowing through conveyor switch.
- F. **WITH UNIT UNPLUGGED**, check connections inside of plug. Remove switch side, side panel and check wiring. Any wires or terminals with burns or discoloration from arcing should be replaced. All wiring, if replaced, should be same or higher rated wire.
- G. If equipped with LED control, check for error message. "AL1" message is a defective center platen probe. "AL2" is a defective booster platen probe. "AL3" is high temperature error of the center platen. "AL4" is high temperature error of the booster platens. "AL3" and "AL4" typically means the solid state relay is defective.

### PROBLEM:

#### 2. Conveyor belts move but no heat.

### SOLUTION:

- A. Check that the unit is on.
- B. Verify voltage is flowing through heat switch.
- C. **TURN OFF SWITCHES AND UNPLUG TOASTER.** Remove left and right side covers. Remove one screw and loosen one screw as shown in Figure 13. Lay unit on the left side (drive chain side). Swivel the bottom of control cabinet open.
- D. Check for loose connections at terminal strip and temperature terminals (see schematic).
- E. Verify that the heater and sensor wires are connected to the proper controller.
- F. Replace all connections or components that have damaged terminals. Replace any damaged wiring with same or higher rated wire.
- G. Check the resistance of the sensor(s) (#503630). If sensor is open, replace. If LED, 1.09k ohms at room temperature. If switch, 108k ohms at room temperature.
- H. If equipped with LED control, check voltage into solid state relays. The voltage input from module should be approximately 5Vdc. Voltage to heater should be 208Vac.
- I. Check the resistance of the heater platens:

Center Platen (#139476): 20 ohms at room temperature

Boost Platens (#503645): 54 ohms at room temperature each

# OWNER'S MANUAL

## MODEL HST13 – AUTOTOAST™ VERTICAL TOASTER



### PROBLEM:

#### 3. Heater platens are hot; conveyor belts do not move.

### SOLUTION:

- A. Check that conveyor switch is on and good.
- B. Make sure there are no loose connections at the switch.
- C. Check the fuse in the adjustment side panel. Replace with type AGC 1.5 amp fuse if necessary.
- D. Check motor to make sure it is connected properly.
- E. Check conveyor speed control setting(CH7, CH7B models). Adjust as needed.
- F. Check for voltage to speed control board (CH7, CH7B models). Check for voltage to the motor (CH7C, CH7D models).
- G. CH7, CH7B models, check for red light on the speed board. If red light is lit, the motor is working too hard or in a stalled state.
- H. Some speed boards have a green light (CH7, CH7B models). If green light is lit then power is going to the board.
- I. Make sure the input voltage switch(es) of the speed board is set at 230V.
- J. CH7C, CH7D check capacitor for proper motor connections.
- K. CH7, CH7B check for DC voltage out of board to motor.
- L. Check all wiring to motor for loose connectors.
- M. Check drive system for loose chain or sprockets. Tighten set screws as needed.
- N. Check belts are not slipping on rollers. Check belts for tears and that the spring tension is applying pressure to the upper roller.

### PROBLEM:

#### 4. Variable Speed Motor (#500940 90 VDC motor) Not Operating (CH7, CH7B Models)

### SOLUTION:

- A. Verify correct voltage to unit and motor.
- B. Make sure conveyor switch (#501864) has power flowing through it.
- C. Check 1.5-amp fuses (#500061).
- D. Check for DC voltage to motor out of board (90VDC Motor).
- E. If red light on board is on, disconnect load from motor by removing chain. If it goes out, look for conveyor binding. If it stays lit, replace motor –there is probably a gearbox problem.
- F. Check DC amp draw to motor by putting meter in series with motor. (Pull wire from A1 on board, put one lead to A1, other to wire pulled from A1.) When red LED on board is on, DC amp reading should be .23 amp approximately.
- G. If green LED is on and red is not, make sure that there is varying DC voltage out of board to motor (terminals A1 & A2 on board) as speed control knob is increased or decreased.
- H. Check ohm reading at motor cord plug (Range between 50-80 Ohms).
- I. Check for oil leaks on motor signifying bad seal or overheating that has taken place. In either case, motor should be replaced.

### PROBLEM:

#### 5. Circuit Board (#140158) not working properly. (CH7, CH7B Models) DO NOT ADJUST POTS ON BOARD WITHOUT CONTACTING FACTORY!

### SOLUTION:

# OWNER'S MANUAL

## MODEL HST13 – AUTOTOAST™ VERTICAL TOASTER



- A. Verify AC voltage to board and DC voltage to motor from board. If there is AC voltage in, but no DC voltage out, replace board.
- B. Check all connections on board and terminal strip.
- C. Verify that board is wired correctly. (See schematic in Owner's Manual.)
- D. Make sure that switch on board is in 230v position.
- E. Check motor plug connection for grease or contamination.
- F. Check speed control pot with meter.
  - a. Two outside terminals should give a full value reading.
  - b. Each outside terminal separately with center terminal should give a reading that varies from 0 to full value as speed control knob is turned or full value to 0 according to which outside terminal meter is connected.

### PROBLEM:

#### 6. Product is over or under toasted.

### SOLUTION:

- A. Check toasting speed. Good toasting will occur in 10 to 23 seconds depending on product and preference.
- B. Check the gap settings. There must be compression of the bun as it feeds into the toaster. Decreasing the gap will increase bun temperature and darken surface color.
- C. Check conditions of toaster platen sheet and belts. Clean both as noted in this manual.
- D. Make sure conveyor belts are not binding.
- E. Check drive system for loose sprockets or chain.
- F. Check that heaters are cycling. Do this by using an amp clamp on either of the wires from the controller to the platen. You are looking for cycling. Also verify that the temperature controllers have power.
- G. Check position of temperature control. This is located behind a small panel on bottom of toaster on some units. After changing temperature setting, allow unit 20 minutes to stabilize.

### PROBLEM:

#### 7. Buns do not feed properly into toaster.

### SOLUTION:

- A. Check condition of the toaster platen sheet to be sure buns are not sticking. Clean sheet as described in daily maintenance. Replace if needed. Life of sheet is 1 – 2 months. Sheet should be rotated daily.
- B. Belts need cleaning as described under the Weekly Maintenance. **DO NOT USE ABRASIVES TO CLEAN.**
- C. Check toaster platen sheet installation. Sheet should be creased in middle so that platen is covered totally on both sides.
- D. Toaster gap set too close or too far. See instructions on Page 1, Number 10.

### PROBLEM:

#### 8. Outside Bun Toasted, Internal Bun not toasted. (No heat on Center Platen) serial no's 0601TS0670 Through 928.

# OWNER'S MANUAL

## MODEL HST13 – AUTOTOAST™ VERTICAL TOASTER



### SOLUTION:

- A. High limit switch tripped. Reset switch by depressing "RESET."
- B. If limit switch trips again, loosen fasteners holding it and move up.
- C. Replace center platen thermostat if any further trips.

### REPLACEMENT PARTS

**WARNING: USE OF NON-MARSHALL APPROVED PARTS WILL VOID WARRANTY.**

PART NUMBER	DESCRIPTION	FIGURE
502887	Bearing, Gold	6
134739	Bearing, Teflon	6
132728	Bracket, Bearing	6
135165	Bracket, Bearing Retainer	6
503287	Brush, Motor	Schematic
140001	Bun Guide Asby (S/N 0400TS0419 and After)	3, 4, 5
135120	Bun Guide Asby (S/N 1298TS0048 thru 0400TS0419)	3,5
503910	Capacitor (Single Speed CH7C, CH7D, CH7F)	Schematic
500035	Chain, Roller #35 (2.25 ft long)	7
140158	Circuit Board, 230V	Schematic
143852	Control, 3 Digit (S/N 929 and After)	Schematic
143855	Control, ECM3 Module 208V (S/N 929 and After) CH7B	Schematic
144563	Control, ECM3 Module 240V International	Schematic
143858	Control, ECM3 Module 240V (S/N 929 and After)	Schematic
148644	Control, ECM3 Module 208V CH7H only	Schematic
148201	Control, Temperature (S/N 0603TS0928 and Before)	Schematic
503702	Control, Temperature (S/N 0798TS008 Through 928)	Schematic
504145	Cord, 12/3 208-240V w/L6-30P Plug (CH7C, CH7CINTLCE)	Schematic
504011	Cord, 12/3 208-240V w/6-20P Plug (CH7H S/N 5572 and After)	Schematic
135202	Cover, Back (CH7 only) (S/N 0598 and Before)	3
139717	Cover, Back (S/N 0598 and Before)	3
139717	Cover, Back (S/N 0599 and After)	4
132729	Cover, Front (CH7 Only) (S/N 0598 and Before)	3
139715	Cover, Front (S/N 0598 and Before)	3
139715	Cover, Front (S/N 0599 and After)	4
132739	Cover, Side (CH7 Only) (S/N 0598 and Before)	3
139716	Cover, Side (S/N 0598 and Before)	3
141248	Cover, Side (S/N 0599 and After)	4
503575	Filter, Electrical Noise	Schematic
500061	Fuse, 1.5 Amp	8, Schematic
500068	Fuseholder	8, Schematic
137605	Guard, Heat Front (S/N 1298TS0048 thru 0400TS0419)	3
140841	Kit, Belt Conversion (2 Belts)	3
140840	Kit, Belt Conversion (CH7 Only) (2 Belts)	3
138599	Kit, Belt Replacement (Belt Tensioner) (1 Belt)	3

# OWNER'S MANUAL

## MODEL HST13 – AUTOTOAST™ VERTICAL TOASTER



140808	Kit, Belt Replacement (Spring Tensioner) (1 Belt)	3
139476	Kit, Center Platen Replacement (Template, Drill Bit)	Schematic
151365	Kit, HST13 Belt Cleaning	14
137454	Kit, Temperature Control (S/N 0798008 and Before)	Schematic
135162	Knob Asby, Adjustment	6
500088	Knob, Small (CH7, CH7B Only)	7, Schematic
500092	Link, Master	7
503909	Motor, Drive AC (Single Speed CH7C, CH7D, CH7F)	Schematic
500940	Motor, Drive DC (Variable Speed)	Schematic
503645	Platen, (Outside)	Schematic
502860	Plug, NEMA L6-20P	Schematic
502321	Plug, NEMA L6-30P CH7C, CHUCINTLCE (S/N 4468 and after)	Schematic
502892	Potentiometer, Rotary (CH7, CH7B Only)	7, Schematic
504023	Relay, Solid State 25A (S/N 929 and After)	Schematic
138021	Roller Asby, 2" DIA (CH7 Only)	7
141406	Roller Asby, 2" DIA	7
134734	Roller Asby, 2" DIA (CH7 Only)	7
134733	Roller Asby, 3" DIA (CH7 Only)	7
140630	Roller Chain Tension Asby (Arm Only)	7
140629	Roller Chain Tension Asby (CH7 Only) (Arm Only)	7
135403	Roller Chain Tension Asby Complete (CH7 Only)	7
139896	Roller Chain Tension Asby Complete	7
503590	Sensor, RTD(S/N 929 and After)	Schematic
503630	Sensor, Thermistor (S/N 928 and Before)	7, Schematic
503665	Sheet, Platen (Package of 5)	5
137629	Spacer, .5"OD X .25"ID	6
134728	Spring	7
502531	Spring	6
500040	Sprocket, 3510 X .500" (CH7G Motor)	7
124643	Sprocket, 3512 X .755" (CH7C Heel)(CH7F, CH7F-15 Heel,Crown)	7
129209	Sprocket, 3515 X .755" (CH7, CH7B, CH7H)	7
126451	Sprocket, 3518 X .755" (CH7C Crown, CH7D)	7
500042	Sprocket, 3520 X .500" (CH7, CH7B, CH7C, CH7F Motor)	7
145299	Sprocket, 3520 X .755" (CH7G Heel)	7
129210	Sprocket, 3524 X .755" (CH7G Crown)	7
501650	Sprocket, 3512 X .500" (CH7D CH7H CH7F-15 Motor)	7
501864	Switch, Rocker (S/N 928 and Before)	5, Schematic
503902	Thermostat, Hi-Limit Center Platen (S/N 0670 Thru 928)	Schematic
503974	Thermostat, Hi-Limit Booster Platens (S/N 0649 thru 928)	Schematic
503770	Washer, Teflon	6

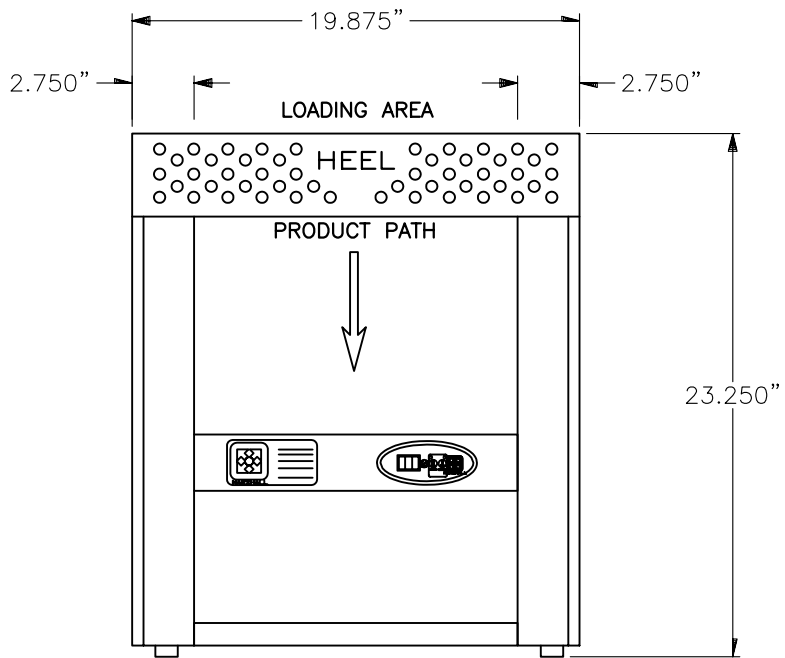

OVERALL DIMENSIONS

FIGURE 1

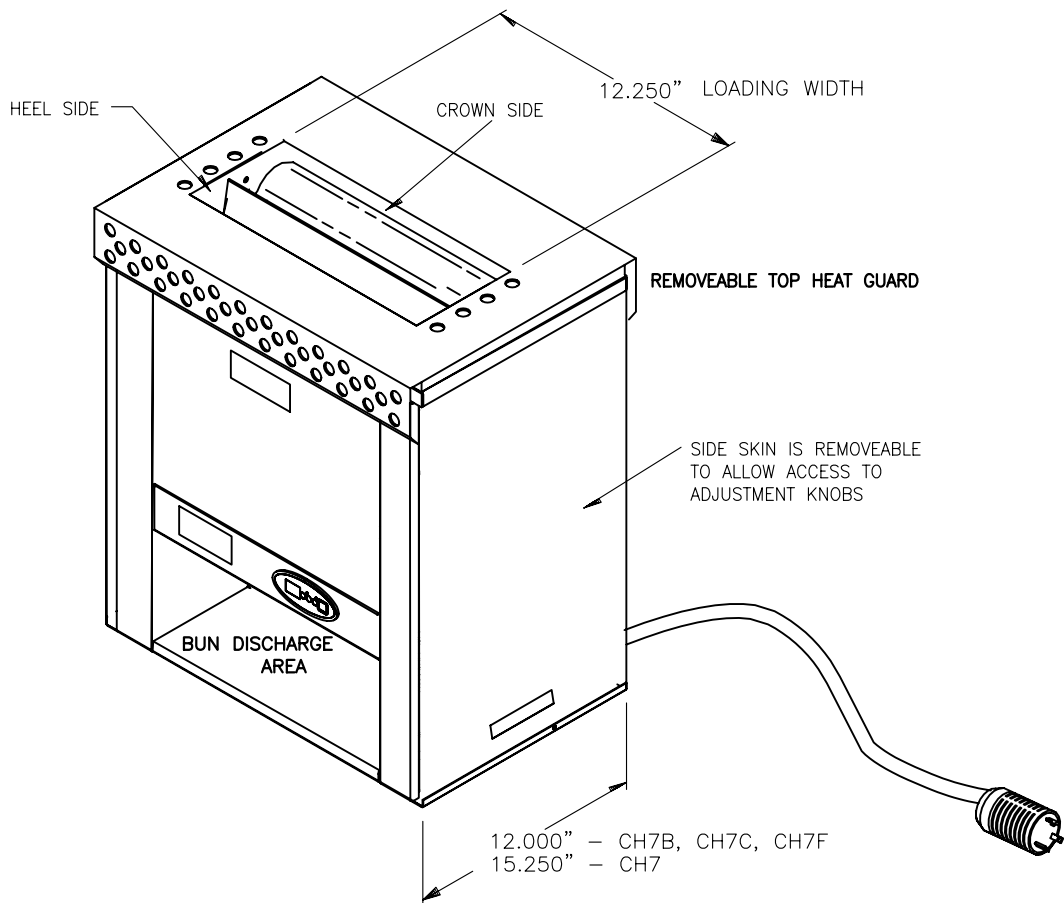

OVERALL DIMENSIONS

FIGURE 2

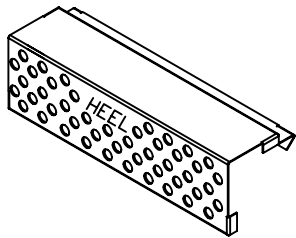

SERIAL NUMBERS  
12980048 THRU 0400TS0419  
GUARD, HEAT FRONT #137605

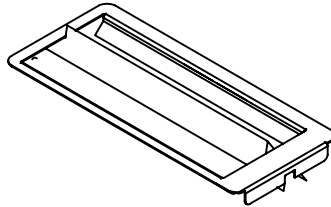

SERIAL NUMBERS  
12980048 THRU 0400TS0419  
BUN GUIDE ASBY #135120

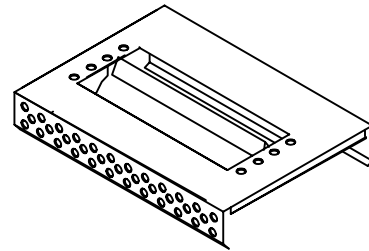

SERIAL NUMBERS  
0400TS0419 AND AFTER  
BUN GUIDE ASBY #140001

## HANG-ON PARTS FOR S/N 1100TS00598 AND BEFORE

COVER, SIDE #139716  
CH7 ONLY  
COVER, SIDE #132739  
(2) REQ'D

CH7B  
BUN GUIDE ASBY #140001  
NOTE: 0400TS0419 AND AFTER

COVER, BACK #139717  
CH7 ONLY  
COVER, BACK #135202

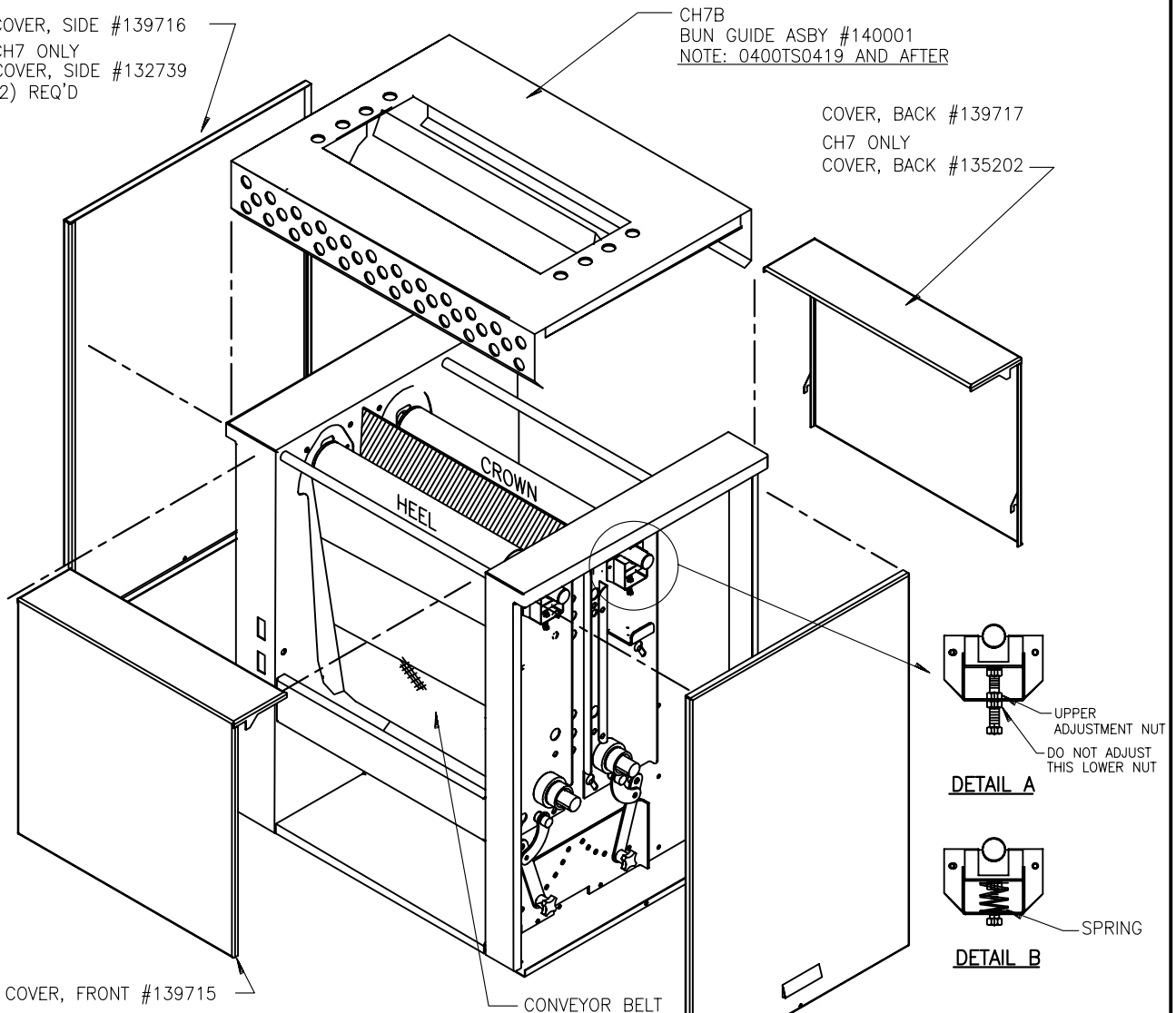

TO ORDER BELT REPLACEMENT KIT, DETERMINE TENSION STYLE BY LOOKING AT DETAIL A AND DETAIL B. IF TOASTER IS DETAIL A (WITH BOLTS), THEN ORDER KIT #138599. IF TOASTER IS DETAIL B (WITH SPRING), THEN ORDER KIT #140808. A CONVERSION KIT IS AVAILABLE TO CONVERT BOLTS TO SPRINGS WHEN REPLACING BELTS. FOR CH7, ORDER #140840. FOR CH7B, ORDER #140841.

HANG-ON PARTS  
FIGURE 3

# HANG-ON PARTS FOR S/N 0201TS00599 AND AFTER

CH7B  
BUN GUIDE ASBY #140001  
NOTE: 0400TS0419 AND AFTER

CH7B, CH7C, CH7F  
COVER, SIDE #141248  
2 REQUIRED

CH7B, CH7C, CH7F  
COVER, BACK #139717

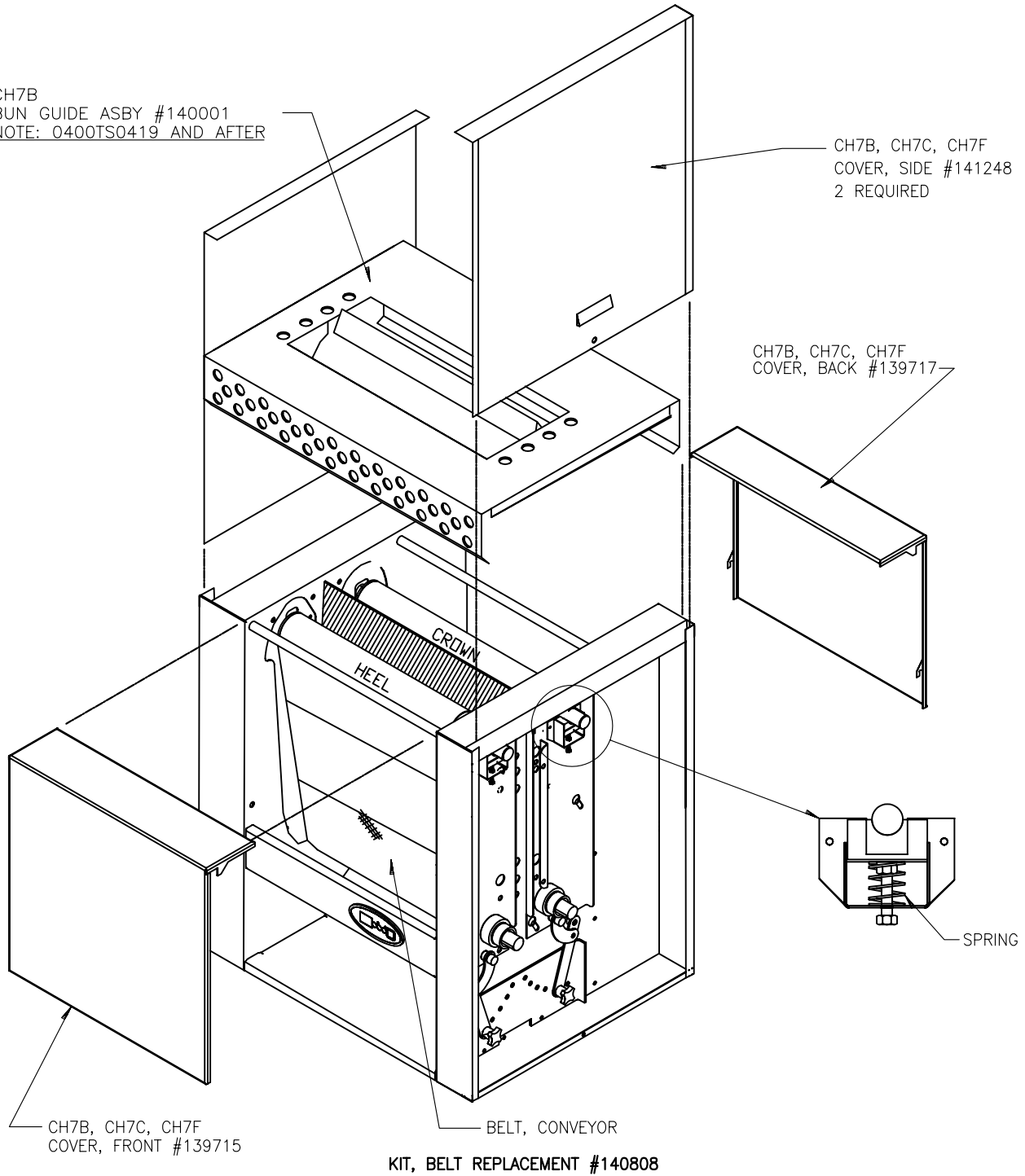

HANG-ON PARTS  
FIGURE 4



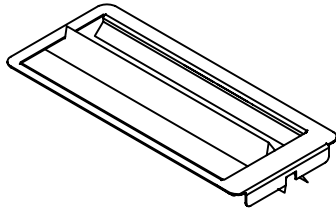

SERIAL NUMBERS  
12980048 THRU 0400TS0419  
BUN GUIDE ASBY #135120  
CH7

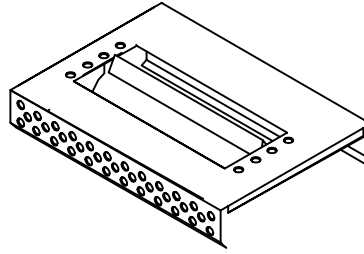

SERIAL NUMBERS  
0400TS0419 AND AFTER  
BUN GUIDE ASBY #140001  
CH7B, CH7C, CH7F

SHEET, PLATEN  
ORDER REPLACEMENTS AS A  
PACKAGE OF 5 SHEETS,  
PACKAGE P/N 503665

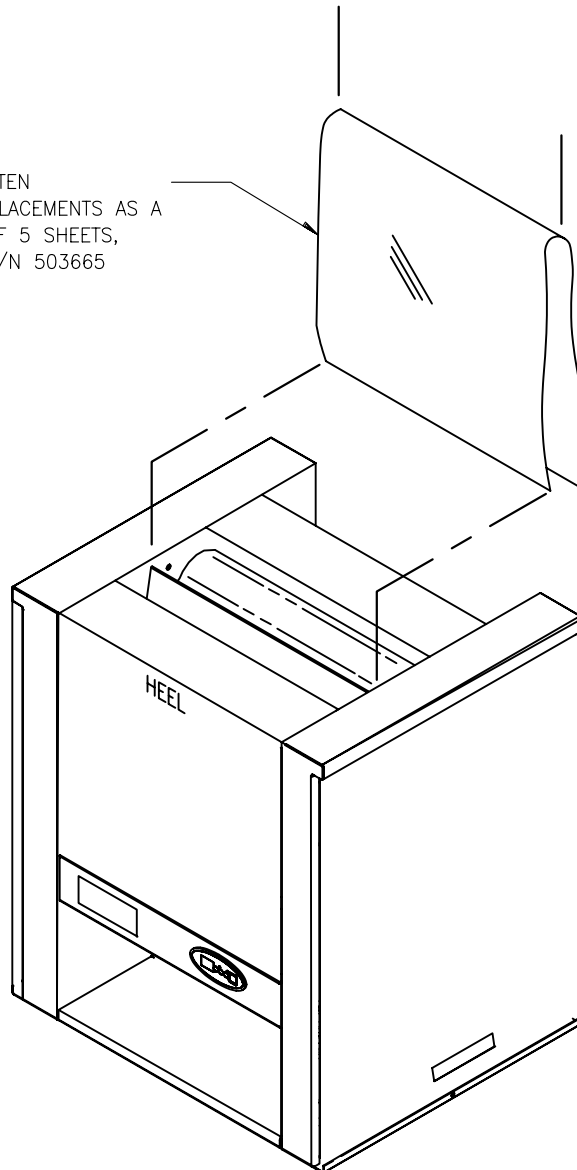

SWITCHES AND TOASTER PLATEN SHEET

FIGURE 5

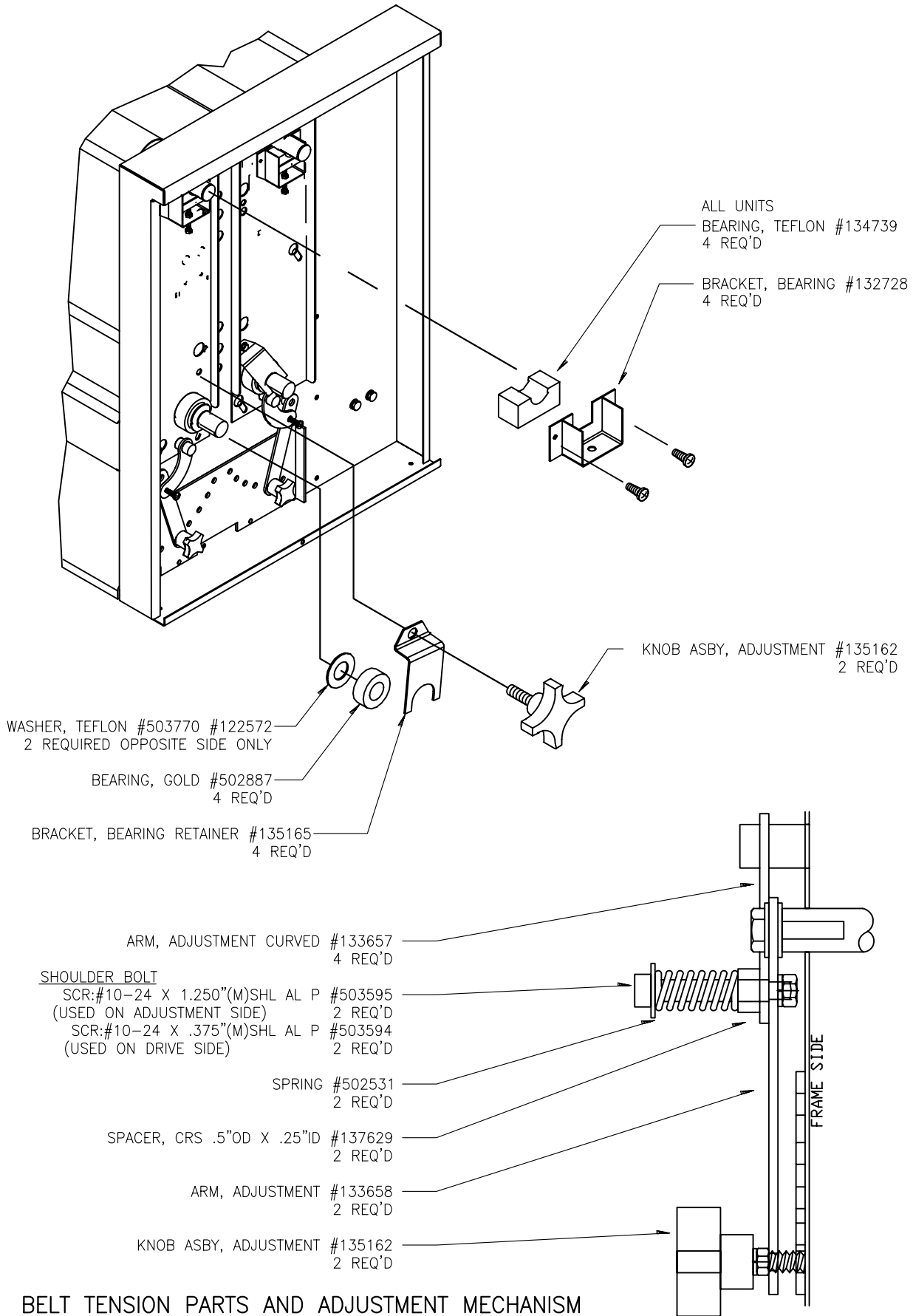

BELT TENSION PARTS AND ADJUSTMENT MECHANISM

FIGURE 6

ROLLER ASBY, TOP CROWN

#134733  
ROLLER ASBY, 3" DIA  
CH7

#141406  
ROLLER ASBY, 2" DIA  
CH7B CH7C CH7D CH7F CH7F-15

#503630  
SENSOR, THERMISTOR  
2 REQ'D

SPROCKET ASBY (ROLLER)

#129209  
SPROCKET, 3515 X .755"  
CH7 CH7B CH7H

#126451  
SPROCKET, 3518 X .755"  
CH7C CH7D

#124643  
SPROCKET, 3512 X .755"  
CH7F CH7F-15

#129210  
SPROCKET, 3524 X .755"  
CH7G

ROLLER ASBY, BOTTOM HEEL

#138021  
ROLLER ASBY, 2" DIA  
CH7

#141406  
ROLLER ASBY, 2" DIA  
CH7B CH7C CH7D  
CH7F CH7F-15

SPROCKET (MOTOR)  
#500042  
SPROCKET, 3520 X .500"  
CH7 CH7B CH7C CH7F

#501650  
SPROCKET, 3512 X .500"  
CH7D CH7H CH7F-15

#500040  
SPROCKET, 3510 X .500"  
CH7G

#502892  
POTENTIOMETER, ROTARY  
1 REQ'D

#500088  
KNOB, SMALL  
1 REQ'D  
CH7 CH7B ONLY

ROLLER ASBY, TOP HEEL

#134734  
ROLLER ASBY, 2" DIA  
CH7

#141406  
ROLLER ASBY, 2" DIA  
CH7B CH7C CH7D  
CH7F CH7F-15

SPRING TENSION ASBY

SPROCKET ASBY (ROLLER)

#129209  
SPROCKET, 3515 X .755"  
CH7 CH7B CH7H

#124643  
SPROCKET, 3512 X .755"  
CH7C CH7F CH7F-15

#126451  
SPROCKET, 3518 X .755"  
CH7D

#145299  
SPROCKET, 3520 X .755"  
CH7G

ROLLER ASBY, BOTTOM HEEL

#138021  
ROLLER ASBY, 2" DIA  
CH7

#141406  
ROLLER ASBY, 2" DIA  
CH7B CH7C CH7D  
CH7F CH7F-15

#500035  
CHAIN, ROLLER #35  
2.25 FEET LONG  
#500092  
LINK, MASTER  
1 REQ'D

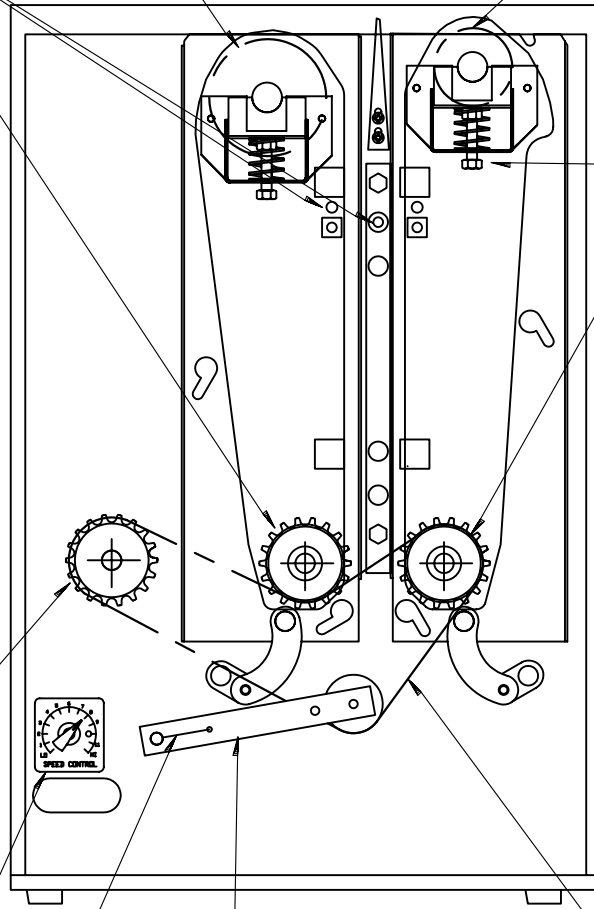

#134728  
SPRING  
1 REQ'D

#139896  
TENSION ARM COMPLETE ASBY  
ALL MODELS EXCEPT CH7

#140630  
TENSION ARM ONLY  
ALL MODELS EXCEPT CH7

#135403  
TENSION ARM COMPLETE ASBY  
CH7 ONLY

#140629  
TENSION ARM ONLY  
CH7 ONLY

DRIVE SIDE W/ COVER REMOVED

INTERNAL PARTS AND DRIVE COMPONENTS

FIGURE 7

SHOWN WITH SIDE PANEL OFF

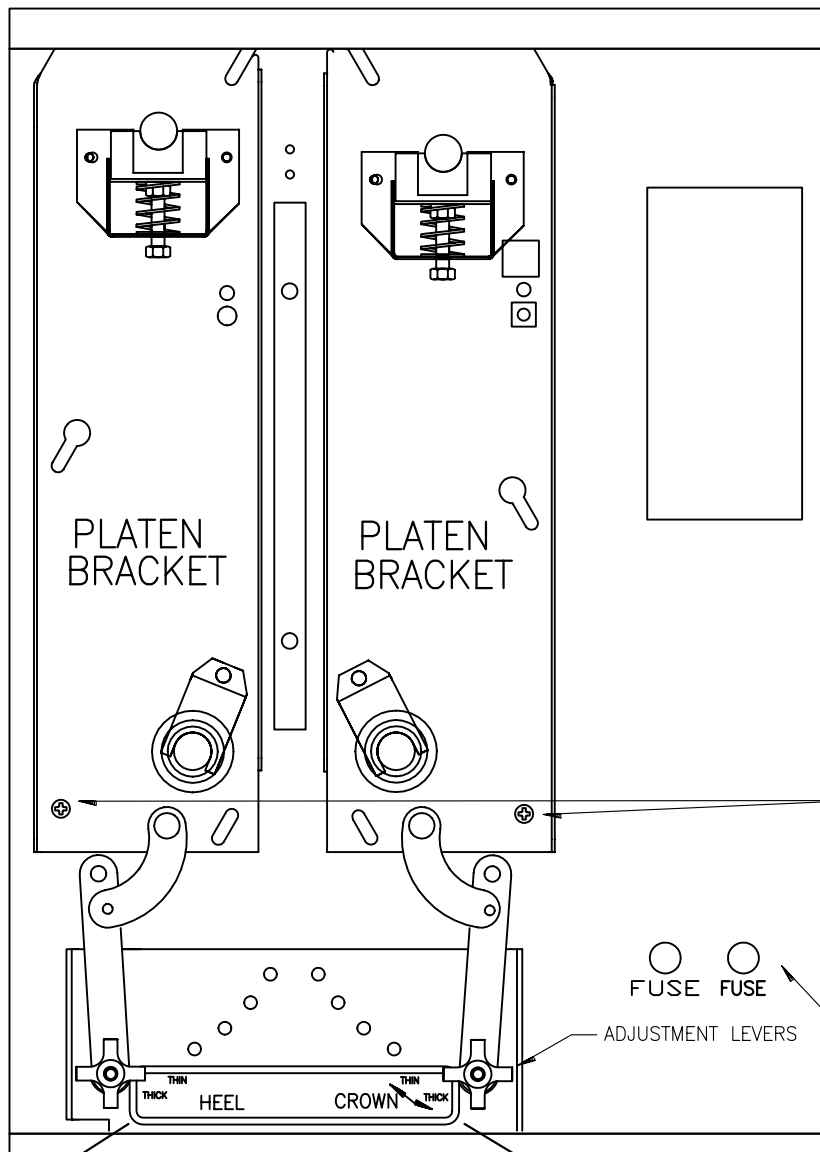

IMPORTANT  
SOME EARLY UNITS  
ARE EQUIPPED WITH  
(2) SHIPPING SCREWS.  
THESE MUST BE REMOVED  
PRIOR TO INSTALLATION  
AND OPERATION OF  
TOASTER.

FUSE FUSE

ADJUSTMENT LEVERS

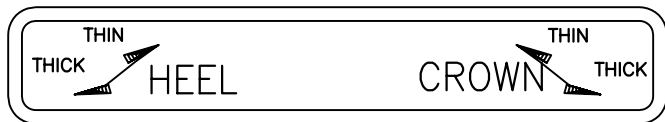

ADJUSTABLE GAP SETTING

ADJUSTMENT LEVER OPERATION

#500068  
FUSEHOLDER  
2 REQ'D

#500061  
FUSE, 1.5 AMP  
2 REQ'D

FIGURE 8

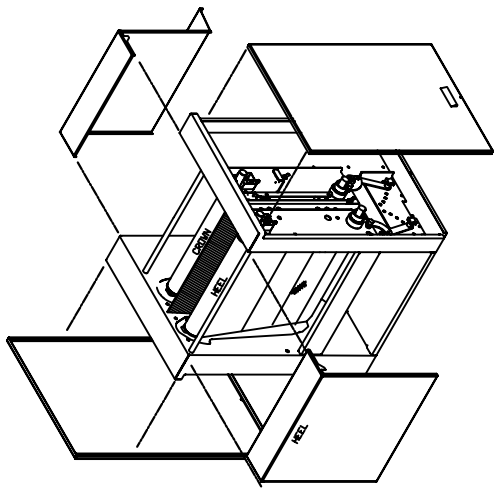

STEP 1. UNPLUG POWER TO TOASTER. REMOVE FRONT, BACK, AND SIDE COVERS. NOTE AT THIS TIME IF BELT HAS A STITCHED DIAGONAL SEAM. IF SO, CONTACT MARSHALL AIR CUSTOMER SERVICE.

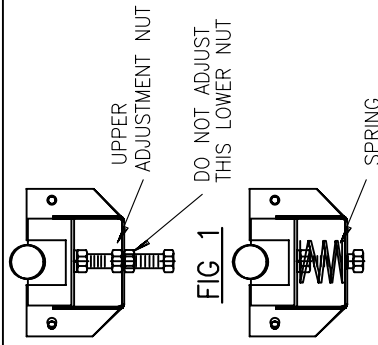
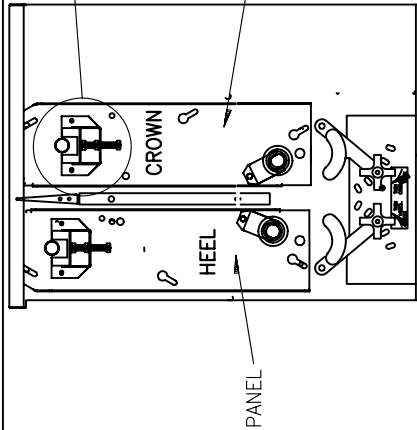
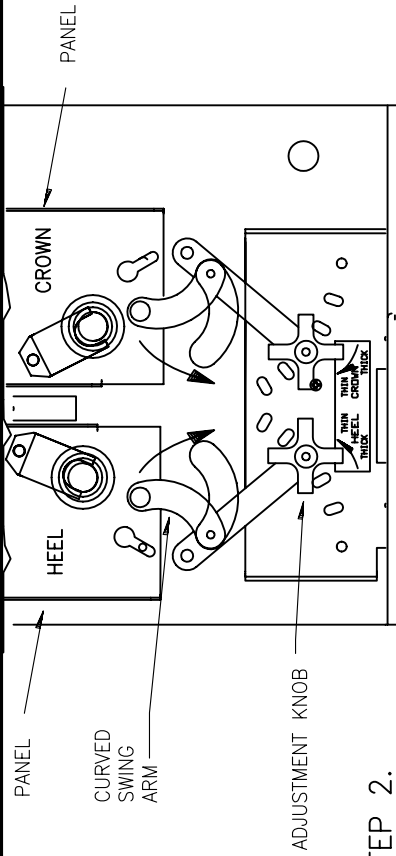

FIG 2

STEP 3. DETERMINE TENSION TYPE IF FIG 1 CONTINUE. IF FIG. 2 WITH SPRING GO DIRECTLY TO STEP 10. LOOSEN UPPER ADJUSTMENT NUT ONLY. DO NOT LOOSEN LOWER NUT. MAKE SURE TO LOOSEN UPPER NUT ENOUGH TO REMOVE PANEL FROM UNIT.

TOOLS NEEDED: 1/2" WRENCH  
7/16" SOCKET WRENCH  
MARSHALL SHAFT JIG #138600



STEP 2.

NOTE AND MARK THE ADJUSTMENT KNOB POSITION. PULL UP ON THE CURVED SWING ARM SO THAT IT COMES LOOSE FROM ROUND PIN ON THE PANEL. IT IS NOT NECESSARY TO REMOVE BOTH CROWN AND HEEL ARMS UNLESS BOTH BELTS ARE BEING REPLACED.

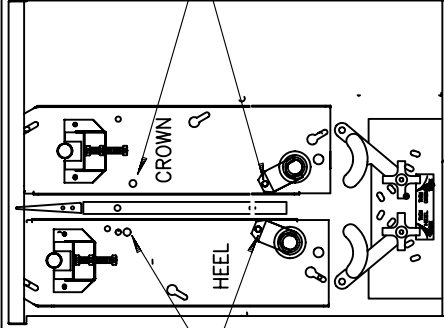

REMOVE IF REPLACING HEEL SIDE BELT  
REMOVE IF REPLACING CROWN SIDE BELT

STEP 4. REMOVE BOLTS THAT HOLD PANEL IN PLACE. REMOVE PANEL BY LIFTING PANEL OVER RIVET HEADS. THIS ALLOWS BELT TO BE SLID OUT THROUGH OPENING. REMOVE LARGE WASHER ON END OF BOTTOM ROLLER TO EASE REMOVAL. REMOVE OLD BELTS FROM TOASTER.

BELT REMOVAL INSTRUCTIONS

SEE FIGURE 10, 11 FOR INSTALLATION

FIGURE 9

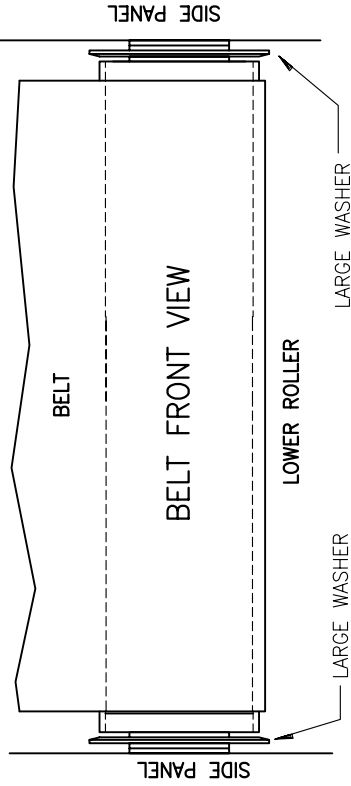

**STEP 5.** INSTALL NEW BELT THROUGH OPENING AND ONTO LOWER AND UPPER ROLLERS. MAKE SURE BELT IS BETWEEN LARGE WASHERS ON LOWER ROLLER AS SHOWN ABOVE.

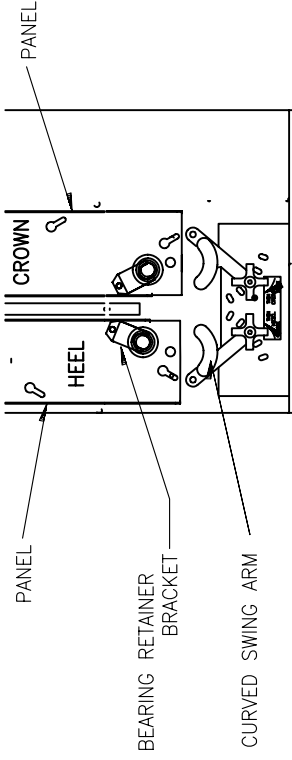

**STEP 6.** INSTALL PANEL AND BOLTS BACK ONTO TOASTER. MAKE SURE TO PUT BEARING RETAINER BRACKET AND CURVED SWING ARM BACK IN PLACE ALSO MAKE CERTAIN ADJUSTMENT KNOB IS IN SAME POSITION AS IN STEP 2.

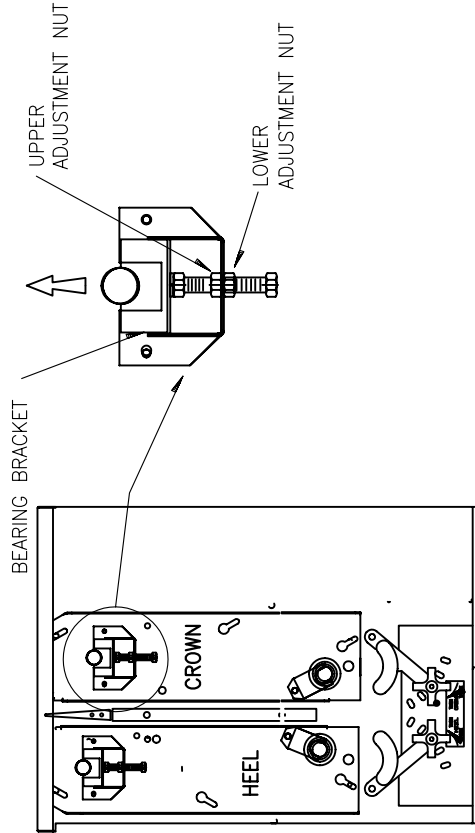

**STEP 7.** USING YOUR HAND, PULL UP ON THE BEARING BRACKET UNTIL ROLLER HAS TIGHTENED BELT. AT THIS TIME, FINGER TIGHTEN UPPER ADJUSTMENT NUT.

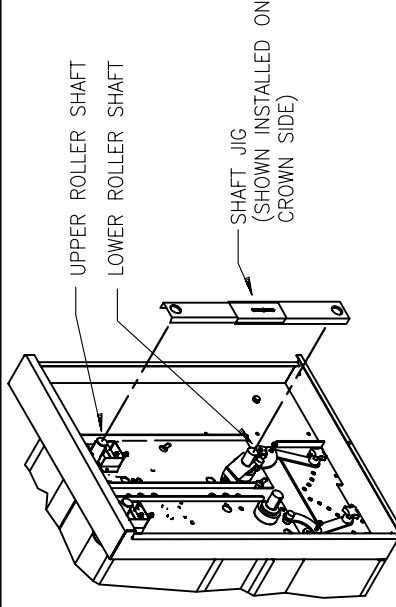

SHAFTS MUST BE PARALLEL AS FIRST STEP TO OBTAINING CORRECT BELT TRACKING.

**STEP 8.** ON OPPOSITE SIDE (DRIVE CHAIN SIDE) OF TOASTER, LOOSEN SCREW OF SHAFT JIG, AND INSERT UPPER AND LOWER SHAFTS THROUGH HOLES. TIGHTEN SCREW AND REMOVE JIG FROM SHAFTS. PLACE JIG ON UPPER ROLLER SHAFT ON SIDE OF TOASTER SHOWN ABOVE. TIGHTEN OR LOOSEN ADJUSTMENT NUT AS NEEDED SO THAT LOWER ROLLER SHAFT FITS THROUGH LOWER HOLE.

**TOOLS NEEDED:** 1/2" WRENCH  
7/16" SOCKET WRENCH  
MARSHALL SHAFT JIG #138600

NON-GUIDED BELT INSTALLATION INSTRUCTIONS

SEE FIGURE 9 FOR BELT REMOVAL INSTRUCTIONS  
SEE FIGURE 11 FOR FURTHER INSTALLATION INSTRUCTIONS

**FIGURE 10**

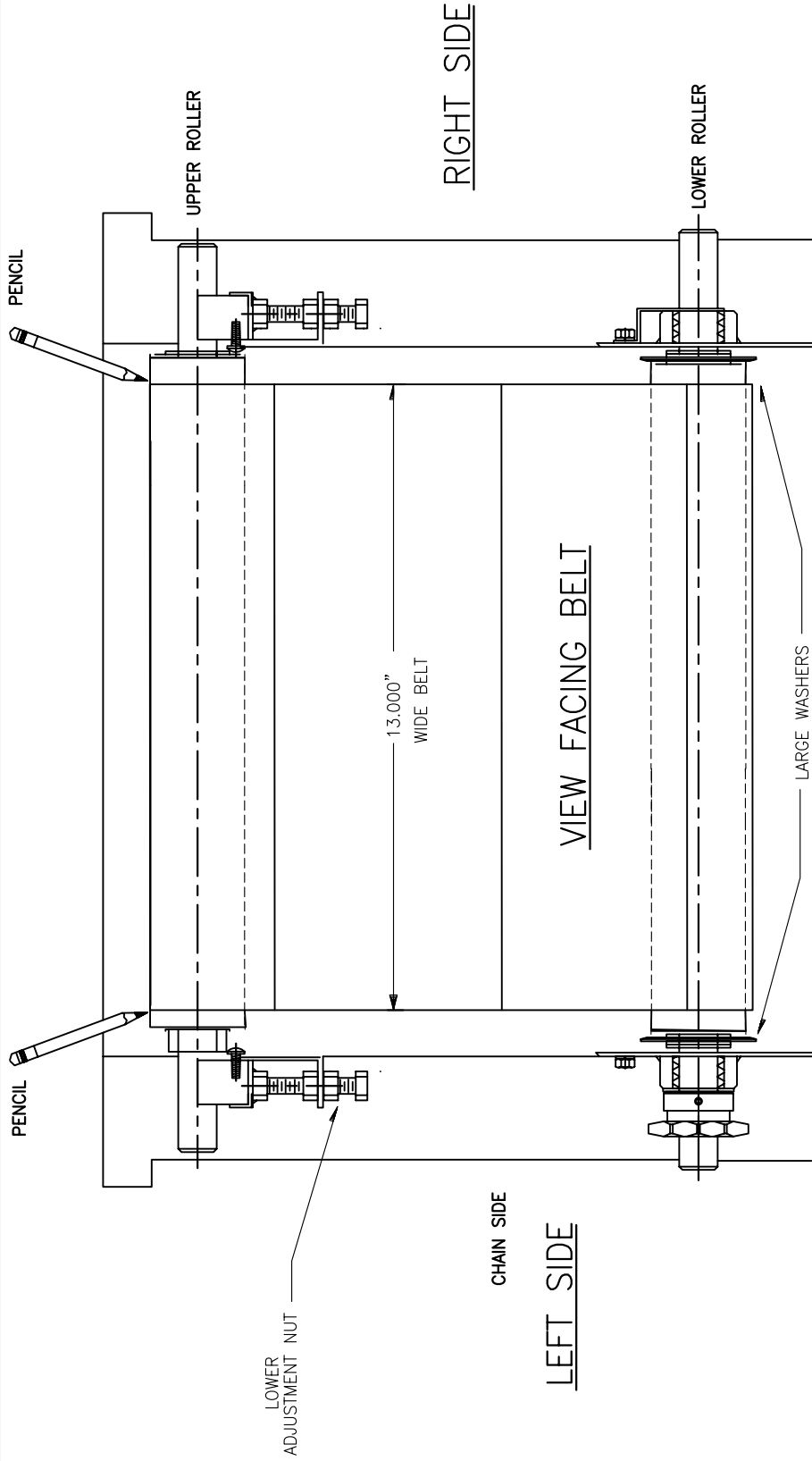

STEP 9. POSITION BELT ON ROLLERS AS SHOWN AND RUN CONVEYOR FOR A FEW MINUTES. THIS ALLOWS BELT TO ESTABLISH A TRACK. WITH UNIT TURNED OFF, PLACE A PENCIL MARK ON ROLLER, ON EACH SIDE OF THE BELT. TURN TOASTER CONVEYOR ON HIGH SPEED AND WATCH FOR MOVEMENT LEFT OR RIGHT BY WATCHING WHICH PENCIL MARK IS COVERED. BELT USUALLY MOVES LEFT SO LOOSEN ADJUSTMENT NUT 1.5 OR MORE TURNS AS NEEDED ON THE SIDE OPPOSITE FROM THE SIDE TO WHICH IT MOVES. IT MAY TAKE REPEATED PENCIL MARKS AND NUT ADJUSTMENTS BEFORE BELT STOPS MOVING TOWARD SIDE OF TOASTER.

TOOLS NEEDED: 1/2" WRENCH  
 7/16" SOCKET WRENCH  
 MARSHALL SHAFT JIG #138600

NON-GUIDED BELT INSTALLATION INSTRUCTIONS

SEE FIGURE 10 FOR BELT REMOVAL INSTRUCTIONS  
 SEE FIGURE 12 FOR FURTHER INSTALLATION INSTRUCTIONS

FIGURE 11

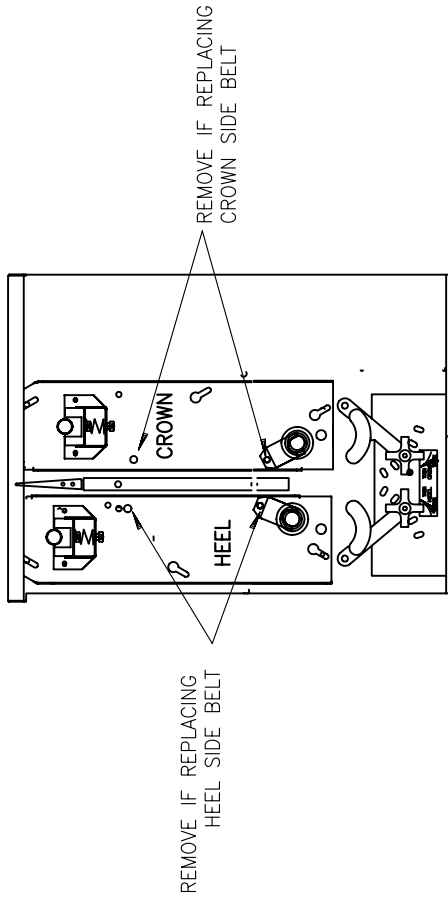

**STEP 10.** REMOVE HAND KNOBS THAT HOLD PANEL IN PLACE. REMOVE PANEL BY LIFTING PANEL OVER RIVET HEADS. THIS ALLOWS BELT TO BE SLID OUT THROUGH OPENING. NOTE POSITION AND ORDER OF SPACERS.

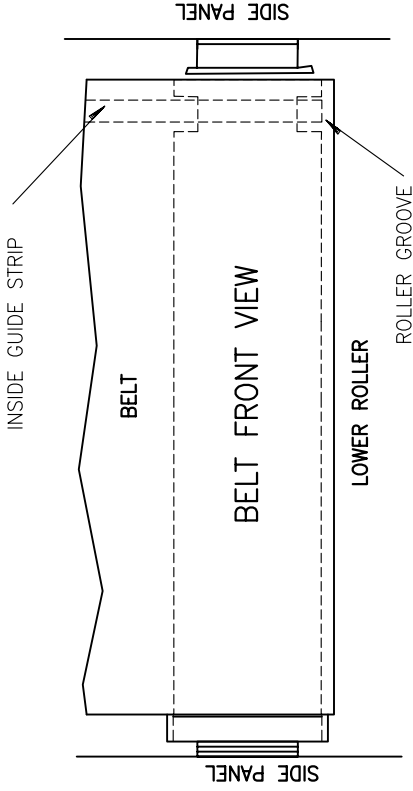

**STEP 11.** INSTALL NEW BELT THROUGH OPENING AND ONTO LOWER AND UPPER ROLLERS. MAKE SURE THE GUIDE END OF THE BELT IS ON THE END CLOSEST TO YOU AND IN THE GROOVE CREATED BY THE END OF THE ROLLER AND SPACERS. BE SURE TO INSTALL THE SPACERS AS THEY WERE.

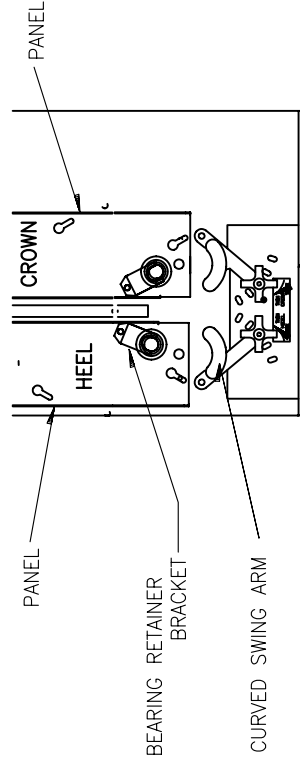

**STEP 12.** INSTALL PANEL. ALIGN PIN INTO SLOTS AND PUT KNOBS BACK ONTO THE TOASTER. MAKE SURE TO PUT BEARING RETAINER BRACKET AND CURVED SWING ARM BACK IN PLACE ALSO MAKE CERTAIN ADJUSTMENT KNOB IS IN SAME POSITION AS IN STEP 2.

**STEP 13.** INSTALL SIDE COVERS ONLY AND RUN UNIT. MAKE SURE BELT IS MOVING CORRECTLY AND GUIDE IS IN ROLLER GROOVES. PLACE ALL COVERS BACK ON UNIT.

GUIDED BELT REMOVAL AND INSTALLATION INSTRUCTIONS

FIGURE 12

TOOLS NEEDED: 1/2" WRENCH  
7/16" SOCKET WRENCH  
MARSHALL SHAFT JIG #138600



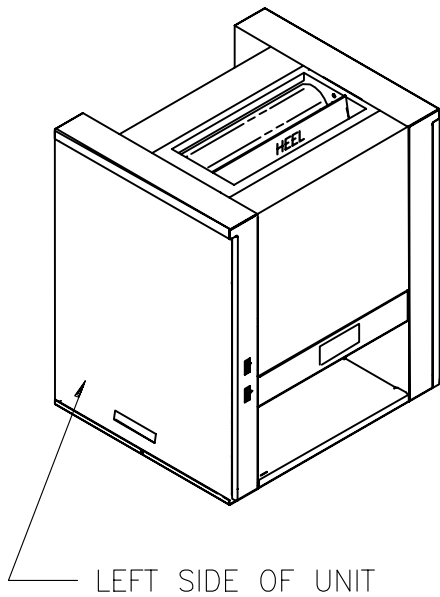

1. TURN UNIT OFF AND UNPLUG
2. REMOVE BOTH SIDE COVERS
3. LOOSEN SCREW "A" ON BOTH SIDES OF TOASTER.
4. REMOVE SCREW "B" ON BOTH SIDES OF TOASTER.
5. LAY UNIT ON LEFT SIDE TO ALLOW BOTTOM PANEL TO SWING OPEN
6. BOTTOM OF CONTROL CABINET SWINGS DOWN GIVING ACCESS TO CONTROLS
7. REAR OF CABINET IS CAULKED. ALONG LINE AT "C". DO NOT BREAK THESE SEALS

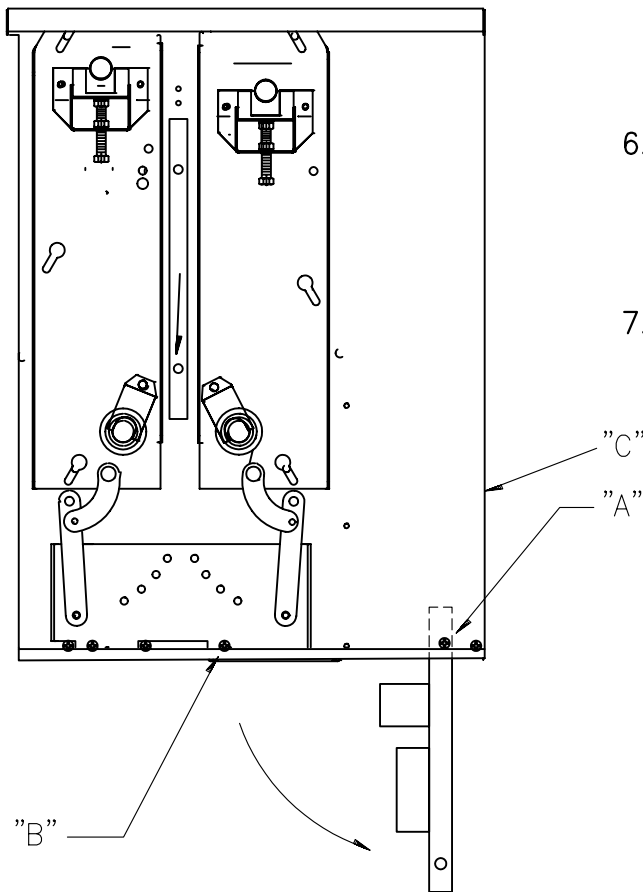

CONTROL CABINET ACCESS INSTRUCTIONS

FIGURE 13

# WEEKLY BELT CLEANING INSTRUCTIONS

AUTOTOAST™ MODEL HST13, HST13S



## 1. Supplies



Scotch-Brite™ Quick Clean Griddle Liquid #700-40  
Scotch-Brite™ All Purpose Scouring Pad #9488R  
Heat Resistant Gloves (Restaurant provided)  
Clean Towel (Restaurant provided)

## 2. Turn Unit OFF



Turn power OFF (display should read "Hi").  
**PUT ON HEAT RESISTANT GLOVES.**  
Belts are to be cleaned "in place" while toaster is still at operating temperature.

## 3. Bun Guide and Covers **USE GLOVES**



Remove Bun Guide, Front and Rear Covers.

## 3. Apply Cleaner to Pad **USE GLOVES**



Apply Scotch-Brite™ Quick Clean Griddle Liquid to the Scotch-Brite™ All Purpose Scouring Pad  
**DO NOT POUR CLEANER ONTO BELT.**

## 4. Clean Belt **USE GLOVES**



Lightly rub width of the exposed belt in circular motion.

## 5. Rotate Belt **USE GLOVES**



Pressing the ON/OFF button to start and stop the belt, rotate the belt and clean the next section. Repeat for both belts.  
"Lo" will move belt.  
"Hi" will stop belt.

## 6. Rinse Belt **USE GLOVES**



Rinse belt by wiping with a clean, damp, sanitized towel. Frequently rinse towel to remove accumulated soil and cleaner residue.

## 7. Platen Sheet **USE GLOVES**



Remove Platen Sheet. Clean using current procedures as described in the owner's manual. Reinstall when clean. If sheet has cuts, holes or cannot be cleaned, replace with a new sheet.

## 8. Bun Guide and Covers **USE GLOVES**



After cleaning, reinstall Front and Rear Covers and Bun Guide. Clean and save the All Purpose Scouring Pad for the next belt cleaning.

To reorder weekly belt cleaning supplies, contact a Marshall Parts Distributor.

# INSTRUCCIONES DE LIMPIEZA SEMANAL

AUTOTOAST™ MODEL HST13, HST13S



## 1. Suplementos



Scotch-Brite™ liquido para limpieza rapida de planchas de cocina #700-40  
Scotch-Brite™ estropajo para todo proposito #9488R  
Guantes de resistencia caliente(restaurante provee)  
Toalla de limpieza (restaurante provee)

## 2. Apagar la unidad



Apagar la unidad (en la pantalla se lee "Hi"alto). Pongase los guantes de resistencia caliente. Las bandas para su limpieza tienen que estar "en su lugar" Mientras la tostadora sigue en su temperatura de operación.

## 3. Guia de panes y covertores **USE GUANTES**



Remover la guia de panes, los covertores de la parte trasera y delantera.

## 3. Aplicar el limpiador al estropajo **USE GUANT**



Aplique Scotch-Brite™ liquido de limpieza rapida de planchas de cocina al, Scotch-Brite™ estropajo para todo proposito  
**No echar el liquido de limpieza en la banda.**

## 4. Limpiar Bandas **USE GUANTES**



Estregar despacio la anchura de la banda sin que quede descubierta haciendo movimiento circular.

## 5. Rotar Las Bandas **USE GUANTES**



Presionando el boton de ON/OFF de empezar y parar bandas, rote las bandas y limpie la proxima seccion. Repitiendo el mismo paso a las mismas bandas.  
"LO" va a mover bandas.  
"HI" va a parar bandas.

## 6. Enjuagar Bandas **USE GUANTES**



Enjuague bandas pasando un trapo limpio, humedo, tolla sanitada. Enjuague la toalla frecuentemente para remover la suciedad acumulada y residuo de limpieza.

## 7. Hoja De Cristal **USE GUANTES**



Remover la hoja de cristal. Usando los procedimientos descritos en el manual del comprador, re-instale cuando este limpio, si la hoja de cristal tiene algun corte, hueco o no se puede limpiar, reemplace con una hoja de cristal nueva.

## 8. Guia de panes y covertores **USE GUANTES**



Después de la limpieza, re-instale los covertores de la parte trasera y delantera y la guia de panes. Limpie y guarde todos los suplementos para la proxima limpieza..

Para ordenar suplementos semanal de limpieza para bandas contactar a su distribuidor de partes Marshall.

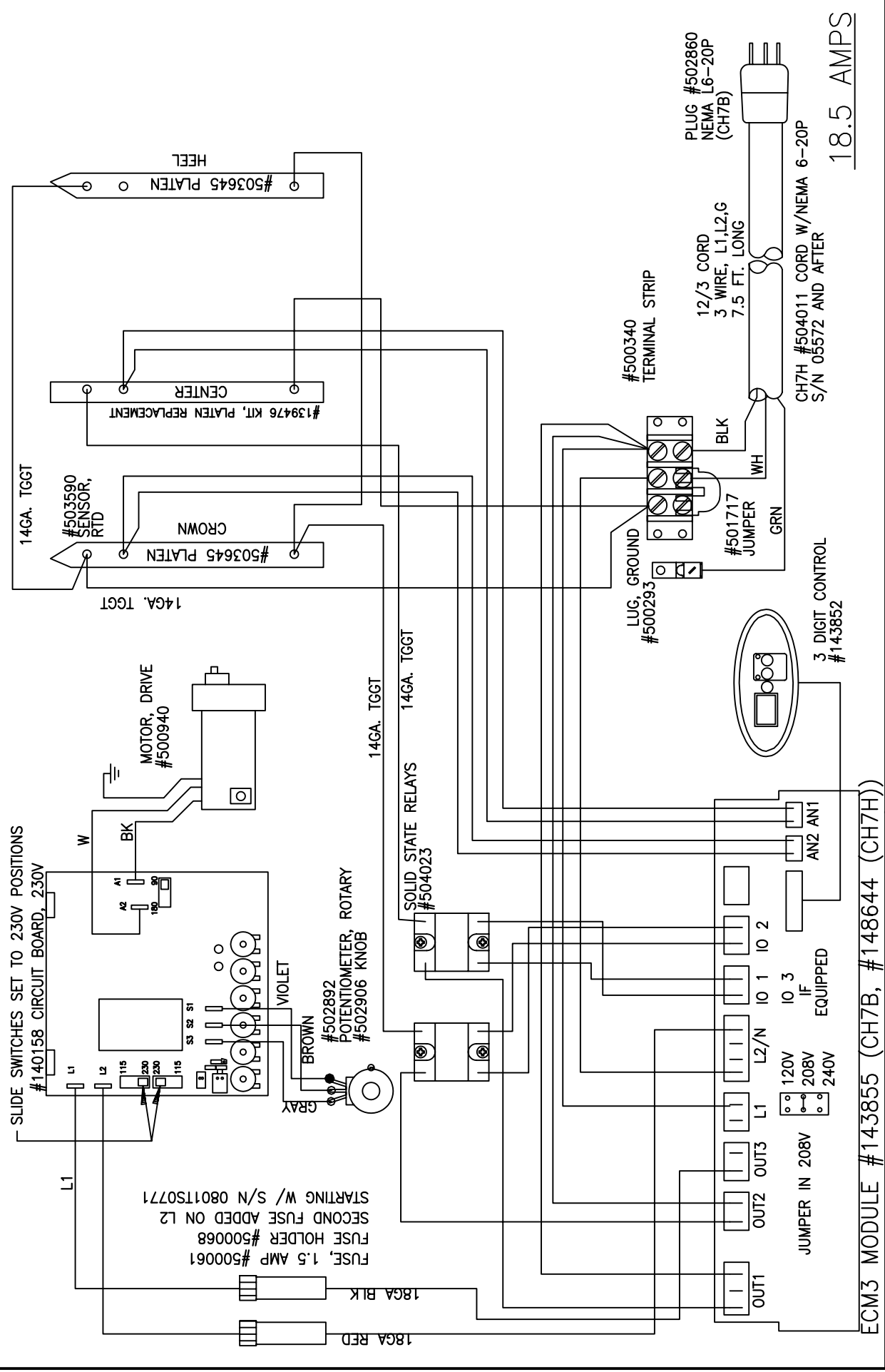

REV	DESCRIPTION	DATE	REV. BY	DATE	REV. DATE:
1	CHG CTR PLATEN TO IO 1	21-AUG-2003	PW	09-JUN-2003	
2	ADDED RELAY 504023	07-SEP-2004	PW		
3	ADDED CH7H	30-JUN-2006	PW		
4	REMOVED 502551 SSR	11-MAR-2009	PW		
5	ADDED CH7H CORD S/N	23-APR-2010	J.L.		

<b>MARSHALL AIR SYSTEMS, INC.</b>	
SCHEMATIC, HST13 208V 1PH	
W/ LED CONTROL, VARIABLE SPEED	
SIZE: A	ROUTE: ELECT
SCALE: 1:1	DWG. NO.: 143851
IMAGE MAY BE REDUCED	REV: 5
NTS	CODE: CH7B CH7H