

---

# **MOFFAT**

## **E32MS CONVECTION OVEN**

**Beginning with S/N 240090  
SERVICE MANUAL**



---

# CONTENTS

This manual is designed to take a more in depth look at the E32M and E32MS convection ovens for the purpose of making the units more understandable to service people.

There are settings explained in this manual that should never require to be adjusted, but for completeness and those special cases where these settings are required to change, this manual gives a full explanation as to how, and what effects will result.

SECTION	PAGE NO.
1. SPECIFICATIONS .....	5
2. INSTALLATION .....	7
3. OPERATION .....	10
3.1 Description of Controls	
3.2 Explanation of Control System	
4. MAINTENANCE .....	13
4.1 Cleaning	
4.2 Routine Procedures	
5. TROUBLE SHOOTING GUIDE.....	15
6. SERVICE PROCEDURES.....	19
6.1 Fault Diagnosis	
6.2 Access	
6.3 Replacement	
6.4 Adjustment / Calibration	
7. ELECTRICAL SCHEMATICS .....	36
8. ELECTRICAL WIRING DIAGRAMS .....	37
9. SPARE PARTS .....	38
10. ACCESSORIES / OPTIONS .....	39

 **IMPORTANT:** MAKING ALTERATIONS MAY VOID WARRANTIES AND APPROVALS.

---

<b>11. PARTS DIAGRAM .....</b>	<b>40</b>
11.1 Main Assembly	
11.2 Control Panel Assembly	
11.3 Gear Plate Assembly	
11.4 Door Assembly	
<b>12. SERVICE CONTACTS .....</b>	<b>47</b>
<b>APPENDIX A. STACKING BASE STAND .....</b>	<b>49</b>
<b>APPENDIX B. DOUBLE STACKING KIT.....</b>	<b>50</b>

# 1. SPECIFICATIONS

**MODEL: E32M**

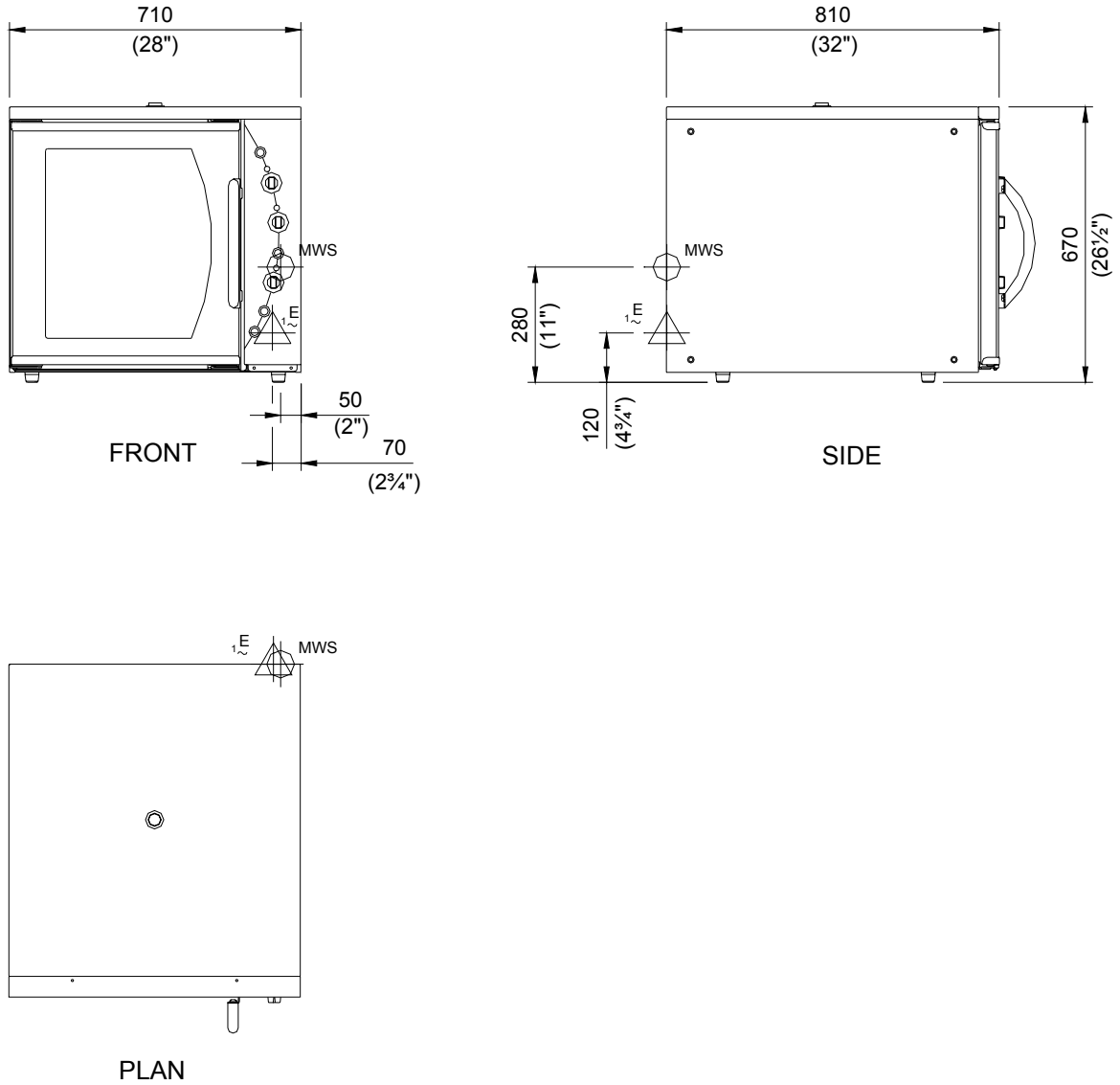

## LEGEND



- Electrical connection entry point



- Water entry - 3/4" BSP hose connection

Dimensions shown in millimetres.  
Dimensions in inches shown in brackets.

**MODEL: E32MS**

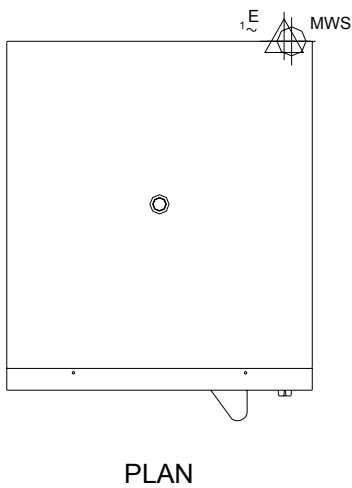
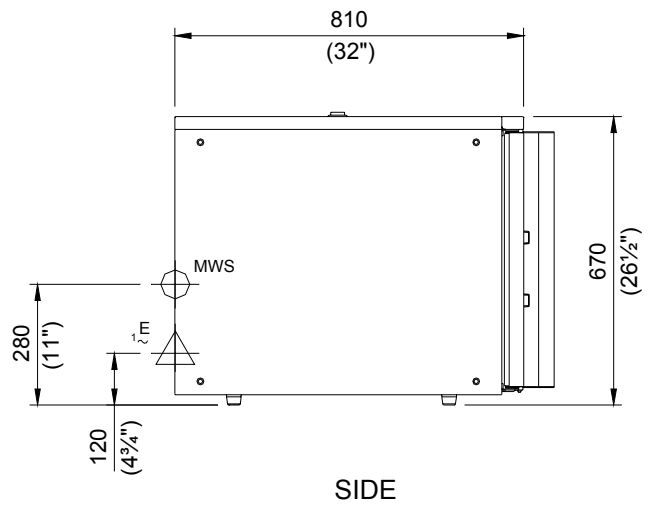
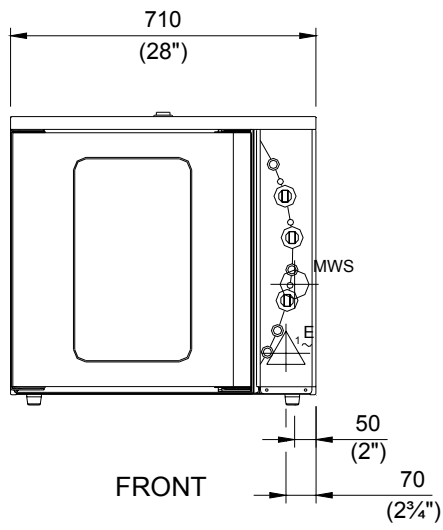

**LEGEND**



- Electrical connection entry point



- Water entry - 3/4" BSP hose connection

Dimensions shown in millimetres.  
Dimensions in inches shown in brackets.

---

## LOCATION

To ensure correct ventilation for the motor and controls the following minimum installation clearances are to be adhered to:

Rear	40mm / 1.5"
Left-hand side	40mm / 1.5"
Right-hand side*	40mm / 1.5"
Top	200mm / 8"

\* Fixed installations require at least 500mm (20") clearance at the right hand side for service accessibility.

## OVEN INTERNAL DIMENSIONS

Width	468 mm / 18.5"
Height	533 mm / 21"
Depth	711 mm / 28"
Oven Volume	0.18 m <sup>3</sup> / 6.3 ft <sup>3</sup>

## OVEN RACK SIZE

Width:	460 mm / 18"
Depth:	660 mm / 26"
No of rack positions:	4
Rack position spacing:	125 mm / 5"

## ELECTRICAL SUPPLY SPECIFICATION OPTIONS

208 V AC 60 Hz, 28.8 A , 6.0 kW @ 208 V  
220-240 V AC 60 Hz, 27.8 A, 6.7 kW @ 240 V  
208-220 V AC 50 Hz, 28.8 A, 6.0 kW @ 208 V  
230-240 V AC 50 Hz, 27.8 A, 6.7 kW @ 240 V

## ELECTRICAL CONNECTION WIRE CONDUCTOR SIZES

Minimum: 4mm<sup>2</sup> / 16 AWG

## WATER SUPPLY CONNECTION

Max Pressure 550 kPa / 5.5 bar / 80 psi  
Min Pressure 100 kPa / 1.0 bar / 15 psi

## 2. INSTALLATION

**⚠ WARNING: THIS APPLIANCE MUST BE GROUNDED.**

**⚠ WARNING: ALL INSTALLATION AND SERVICE REPAIR WORK MUST BE CARRIED OUT BY QUALIFIED PERSONS ONLY.**

### Before Connection to Power Supply

- Remove all packing.
- Check equipment and parts for damage. Report any damage immediately to the carrier and distributor.
- Remove protective plastic coating from the side panels.
- Check that the following parts have been supplied with your oven:

- 4 x Foot assembly
- 4 x Oven racks
- 1 x Water inlet elbow (c/w washer)

- Report any deficiencies to the distributor who supplied the oven.
- Fit the feet to the oven.
- Check that the available power supply is correct to that shown on the rating plate located on the right -hand side panel.

208-220 V AC, 50 Hz, 28.8 A, 6.0 kW  
 208 V AC, 60 Hz, 28.8 A, 6.0 kW  
 230-240 V AC, 50 Hz, 27.8 A, 6.7 kW  
 220-240 V AC, 60 Hz, 27.8 A, 6.7 kW

### Location

- To ensure correct ventilation for the motor and controls the following minimum installation clearances are to be adhered to:

Rear	40mm / 1½"
Left-hand side	40mm / 1½"
Right-hand side*	40mm / 1½"
Top	200mm / 16"

\* Fixed installations require at least 500mm (20") clearance at the right hand side for service accessibility.

- Position the oven in its working position.

**⚠ IMPORTANT: THE OVEN VENT LOCATED ON THE CABINET TOP MUST NEVER BE OBSTRUCTED.**

- Use a spirit level to ensure oven is level from side to side and front to back. (If this is not carried out, uneven cooking could occur). The feet/legs used with bench/

floor mounting or provided with stands are adjustable and will require adjusting in levelling the unit.

- The unit should be positioned such that the operating panel and oven shelves are easily reachable for loading and unloading.

### Electrical Connection

- Remove right hand side panel to allow access to the terminal block and strain relief cable clamp.
- The cable can be fitted through the small grommet and held by the cable clamp.
- Connect cable to the terminals as marked.
- Refit cover panel.

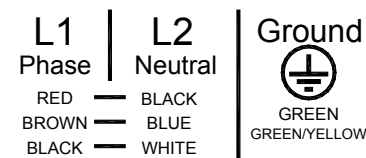

**WARNING: THIS APPLIANCE MUST BE GROUNDED / EARTHED**

Figure

2.1

### Water Connection

- A cold water supply should be fitted to the water inlet (¾" BSP hose connection) which is located on the rear of the right hand side of the unit.
- Alternately, a connection elbow and sealing washer is supplied with this unit for direct connection of a ½" ID hose, and is recommended for easy installation and service.
- Connect water supply - Max inlet pressure 80psi / 550kPa.
- Turn on water supply to check for leaks.

**⚠ IMPORTANT: MAXIMUM INLET WATER PRESSURE IS 550 kPa / 80 psi.**

---

### Before Use

- Operate the oven for about 1 hour at 200°C (400°F) to remove any fumes or odours which may be present.

### Rating Plate Location

The rating plate for the E32M and E32MS convection ovens is located at the bottom front corner of the RH side panel.



Figure 2.3



## 3. OPERATION

**NOTE:** A full user's operation manual is supplied with the product and can be used for further referencing of installation, operation and service.

### 3.1 DESCRIPTION OF CONTROLS

**1. Power**

Depress to switch power on or off (switch illuminates when power is on).

**2. Thermostat**

Temperature range 50 - 320°C (120 - 600°F). Indicator illuminates when elements are cycling ON to maintain set temperature.

**3. Bake Timer**

1 Hour bake timer.  
(Indicator illuminates when "time up" (0) reached, and buzzer sounds).

**4. Roast 'n' Hold**

Depress switch to activate 'Roast 'n' Hold' function. (Switch illuminates when ON).

**5. Roast Timer**

3 Hour roast timer.  
(Indicator illuminates when "time up" (0) reached, and product held at 75°C (167°F).

**6. Steam Switch**

Push switch to activate water injection.  
(Water injects into oven while the button is depressed).

**7. Light Switch**

Push switch to activate lights.

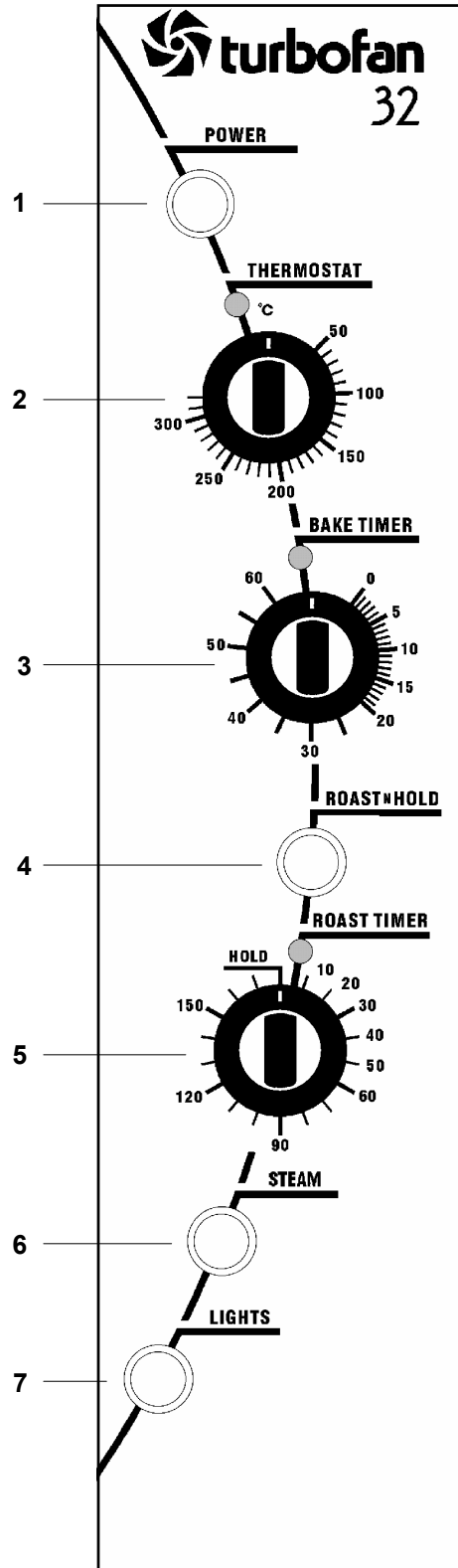

---

## 3.2 EXPLANATION OF CONTROL SYSTEM

The E32M and E32MS Turbofan convection ovens feature multi-function operator controls for which a correct understanding of their operation is required before carrying out any service or fault repair work. The control device functions are explained as follows:

A power switch on the control panel isolates power to the controls of the oven. With the power switch Off all functions of the oven are inoperable.

With the power switch On (illuminated) power is directly supplied to the 60 minute bake timer, steam (water injection) switch, door microswitch, light switch, and the temperature control circuit. The oven circulation fan will operate whenever the power switch is on. The control panel light switch will turn the oven lights on when the door is closed. The oven lights will come on automatically when the door is open, as this is controlled by the door microswitch. The oven fan and heating elements are also controlled by the door microswitch, and will therefore only operate when the door is closed.

The 60 minute timer is a mechanical timer and can therefore be operated with the oven's power switch On or Off. However, only with the oven's power switch On will the switch contacts of the 60 minute timer turn on the time-up buzzer and illuminate the time-up indicator on the control panel. The buzzer and time-up indicator provide indication that the time setting has run down to zero and at this point will remain On continuously until the 60 minute timer has been manually set back to the Off (vertical) position. The 60 minute timer does not control any other part of the oven's operating system as this timer is independent of the temperature control and heating system.

The steam (water injection) switch on the control panel can be operated whenever the power switch is On. The switch is momentary like the light switch and when depressed, will operate the electric solenoid valve at the rear of the oven and inject water across the elements and fan from the flat spray (vertical) nozzle positioned at the rear of the oven elements. Releasing the steam button will close the solenoid valve. This feature is used to instantaneously add steam into the oven.

The temperature control of this oven is with a capillary type thermostat which can be set to a required cooking temperature.

The control panel indicator light above the thermostat knob cycles On and Off with the thermostat to indicate when the elements are on and the oven is heating.

The E32M and E32MS Turbofan convection ovens have 6.5 kW of electric heating elements, comprising of a 3 kW inner coil, and a 3.5 kW outer coil, both of which make up the element assembly around the oven fan. The elements are switched on and off by the main oven thermostat or hold thermostat via a four-pole 25 Amp contactor located inside the control housing. Only two poles of the contactor are used, one for each element coil. Power to the oven thermostat is supplied from the door microswitch, and will therefore only switch the elements on if the oven door is closed.

The circulation fan on the E32M and E32MS ovens reverses direction every 90 seconds for a 50Hz supply (every 75 seconds for 60Hz). Prior to a change of direction the fan motor is switched off for 10 seconds (8½ seconds for 60Hz) to allow the motor/fan to slow down. Cycling of the fan motor is controlled by a continuous cam timer with electric motor. The timer has two cams and switches which supply power alternately to one of two motor supply wires, causing the motor to alternate direction. During the fan motor slow down periods, both cam switches are open and power is not supplied to either of the motor supply wires. When the oven door is opened or the power is switched off the cams will stop. When the oven door is closed or the power switched back on the cam timer will resume its cycle from the point where it stopped.

The fan motor is a split phase continuous capacitor motor with the capacitor externally connected across the motor supply leads. The motor also incorporates an internal thermal trip switch for overheat protection which is auto resetting.

The E32M and E32MS Turbofan convection ovens feature a Roast-and-Hold system which can be used to automatically set the oven to a fixed holding temperature at the end of a timed cooking period. When the Roast-and-Hold switch is turned On the switch will illuminate and switch on a hold relay found

---

inside the control panel. When the relay is switched ON a normally closed switch pole on the relay is opened and the normal power supply to the oven thermostat is isolated. A s e c o n d normally open switch pole is closed and this provides power to the 3 hour roast timer.

If the roast timer is in the Hold (vertical) position the timer switch contacts will be in their normally closed position and supply power directly to the Hold thermostat located behind the control panel. The Hold thermostat is factory set to 75°C (167°F) and will supply power to the heating elements through the heating contactor as required to maintain its preset temperature.

The thermostat heating light will also cycle On/Off as the Hold thermostat maintains temperature.

In the Roast-and Hold mode the 3 hour timer can be set to a selected roasting time. During this time period the normally open switch contacts of the timer are closed. The timer has two change over switches and in this position one is used to supply power to its timing motor and the other is used to switch power directly to the main oven thermostat. During the 3 hour timer run-down period the oven temperature will be controlled by the main oven thermostat to the set temperature and operate as previously described.

When the 3 hour timer has run down and reached the Hold position the two switch contacts change over to their normally closed position which isolates power from the timer motor and the oven thermostat. It also switches power back to the oven hold thermostat. At this point the temperature control is now maintained by the hold thermostat as previously described. To cancel the hold circuit the Roast-and-Hold switch is turned Off. This turns off the contactor which removes power from the 3 hour timer and closes the contactor pole on the contactor that feeds the main oven thermostat. The Hold indicator light above the 3 Hour timer will illuminate whenever the oven is operating in hold mode (Roast 'n Hold selected, and 3 Hour timer at zero position).

The factory preset hold thermostat can be adjusted as required to change the holding temperature if necessary. Refer Service section for this procedure.

The following Troubleshooting Guide should be used to identify any incorrect oven operation. On correct identification of the operating fault the Troubleshooting Guide will make reference to the corrective action required, or refer to the Fault Diagnosis section and/or Service section to assist in correction of the fault.

---

## 4. MAINTENANCE

 **WARNING:** ALL INSTALLATION AND SERVICE REPAIR WORK MUST BE CARRIED OUT BY QUALIFIED PERSONS ONLY.

### 4.1 CLEANING

 **WARNING:** ALWAYS TURN THE POWER SUPPLY OFF BEFORE CLEANING.

 **IMPORTANT:** THIS UNIT IS NOT WATER PROOF.  
DO NOT USE A WATER JET SPRAY TO CLEAN INTERIOR OR EXTERIOR OF THIS UNIT.

#### EXTERIOR

Clean with a good quality stainless steel cleaning compound. Harsh abrasive cleaners may damage the surface.

#### INTERIOR

Ensure that the oven chamber is cool. Do not use wire brushes, steel wool or other abrasive materials. Clean the oven regularly with a good quality oven cleaner. Take care not to damage the fan or the tube at the right side of the oven which controls the thermostat.

#### OVEN RACKS

To remove, slide out to the stop position, raise the front edge up, and lift out.

#### SIDE RACKS

To remove, lift front top to disengage and slide rack forward. To replace, slide top rear slot in rack onto rear stud, then engage front keyhole on front stud.

#### LAMP GLASS

To remove glasses, unscrew anti-clockwise.  
To replace, screw in clockwise.

 **IMPORTANT:** DO NOT OVERTIGHTEN LAMP GLASS.

#### OVEN SEALS

To remove, hold at their centre point and pull forward until they unclip. Remove side seals first, then top and bottom. The seals may be washed in the sink, but take care not to cut or damage them. To replace, ensure that the lip is facing the oven opening. Fit the top and bottom seals first, then the side seals.

#### OVEN DOOR GLASS

Clean with conventional glass cleaners.

---

## 4.2 ROUTINE PROCEDURES

	<b>PROCEDURE</b>	<b>INTERVAL</b>
DOOR SEALS	Check for deterioration.	12 months
DOOR PIVOT BUSHES	Check for wear.	12 months
DOOR CATCHES	Ensure that catches are adjusted such that the door closes properly.	12 months
ELEMENT	Check that element resistance is correct to it's rating (refer 6.3.15).	12 months
WATER NOZZLE	Check for liming in water nozzle.	12 months

## 5. TROUBLE SHOOTING

**⚠ WARNING: ALL INSTALLATION AND SERVICE REPAIR WORK MUST BE CARRIED OUT BY QUALIFIED PERSONS ONLY.**

FAULT	POSSIBLE CAUSE	REMEDY
THE OVEN DOES NOT OPERATE / START	The mains isolating switch on the wall, circuit breaker or fuses are "off" at the power board.	Turn on.
	The power switch on the oven is off.	Depress switch. Switch will illuminate.
	Incorrect electrical supply. <b>(Refer fault diagnosis 6.1.1)</b>	Ensure electrical supply correct.
	Power switch on unit faulty. <b>(Refer fault diagnosis 6.1.1)</b>	Replace. <b>(Refer service section 6.3.4)</b>
FAN DOESN'T OPERATE	Door not closed.	Close door.
	Fan obstructed.	Clear obstruction.
	Door microswitch is out of adjustment. <b>(Refer fault diagnosis 6.1.2)</b>	Adjust. <b>(Refer service section 6.4.2)</b>
	Door microswitch faulty. <b>(Refer fault diagnosis 6.1.2)</b>	Replace. <b>(Refer service section 6.3.2)</b>
	Motor timer faulty. <b>(Refer fault diagnosis 6.1.2)</b>	Replace. <b>(Refer service section 6.3.18)</b>
	Motor capacitor faulty. <b>(Refer fault diagnosis 6.1.2)</b>	Replace. <b>(Refer service section 6.3.19)</b>
	Fan motor faulty.	Replace. <b>(Refer service section 6.3.17)</b>
Wiring.	Check and tighten any loose wiring.	
FAN ONLY OPERATES IN ONE DIRECTION	Motor timer faulty. <b>(Refer fault diagnosis 6.1.2)</b>	Replace. <b>(Refer service section 6.3.13)</b>
OVEN LIGHT NOT ILLUMINATING - DOOR OPEN (AUTOMATICALLY ON)	Blown bulb.	Replace. <b>(Refer service section 6.3.1)</b>
	No power to light. <b>(Refer fault diagnosis 6.1.3)</b>	Correct fault.
OVEN LIGHT NOT ILLUMINATING - DOOR CLOSED (MANUALLY SWITCHED ON)	Blown bulb.	Replace. <b>(Refer service section 6.3.1)</b>
	Light switch faulty. <b>(Refer fault diagnosis 6.1.4)</b>	Replace. <b>(Refer service section 6.3.4)</b>

FAULT	POSSIBLE CAUSE	REMEDY
NO WATER INJECTION / STEAM	<p>Water not turned on.</p> <p>Oven water nozzle blocked.</p> <p>Fault with water valve. <b>(Refer fault diagnosis 6.1.5)</b></p> <p>Steam switch faulty.</p>	<p>Turn water on at water supply.</p> <p>Remove, clean or replace. <b>(Refer service section 6.3.14)</b></p> <p>Service or replace as required. <b>(Refer service section 6.3.12, 6.3.13)</b></p> <p>Replace. <b>(Refer service section 6.3.4)</b></p>
CONTINUOUS WATER OUT OF OVEN WATER NOZZLE	<p>With oven on only—Electrical fault. <b>(Refer fault diagnosis 6.1.6)</b></p> <p>With oven on or off - water valve faulty or requires cleaning.</p>	<p>Correct electrical fault.</p> <p>Service or replace as required. <b>(Refer service section 6.3.12, 6.3.13)</b></p>
60 MINUTE TIMER WILL NOT TIME DOWN	Timer faulty.	Replace. <b>(Refer service section 6.3.7)</b>
60 MINUTE TIMER INACCURATE BELOW 20 MINUTES	<p>Timer not set correctly.</p> <p>Zero (time up) position not set correctly.</p>	<p>For timer settings below 20 minutes, always rotate past 20 minutes, then back to desired time.</p> <p><b>(Refer service section 6.4.6)</b></p>
60 MINUTE TIMER NO TIME UP BUZZER	<p>Buzzer faulty. <b>(Refer fault diagnosis 6.1.7)</b></p> <p>Timer not switching on buzzer. <b>(Refer fault diagnosis 6.1.7)</b></p>	<p>Replace. <b>(Refer service section 6.3.5)</b></p> <p>Replace. <b>(Refer service section 6.3.7)</b></p>
60 MINUTE TIMER NO TIME UP INDICATOR	Indicator faulty. <b>(Refer fault diagnosis 6.1.8)</b>	Replace. <b>(Refer service section 6.3.3)</b>
NO HEAT	<p>No power to thermostat. <b>(Refer fault diagnosis 6.1.9)</b></p> <p>Thermostat faulty. <b>(Refer fault diagnosis 6.1.9)</b></p> <p>Heating contactor faulty. <b>(Refer fault diagnosis 6.1.9)</b></p> <p>Element faulty (blown). <b>(Refer fault diagnosis 6.1.9)</b></p>	<p>Identify fault and correct.</p> <p>Replace. <b>(Refer service section 6.3.9)</b></p> <p>Replace. <b>(Refer service section 6.3.11)</b></p> <p>Replace. <b>(Refer service section 6.3.15)</b></p>
NO TEMPERATURE CONTROL (TEMPERATURE OVERRUN)	<p>Heating contactor faulty. <b>(Refer fault diagnosis 6.1.9)</b></p> <p>Thermostat faulty. <b>(Refer fault diagnosis 6.1.10)</b></p>	<p>Replace. <b>(Refer service section 6.3.11)</b></p> <p>Replace. <b>(Refer service section 6.3.9)</b></p>

FAULT	POSSIBLE CAUSE	REMEDY
SLOW RECOVERY	Oven in 'Roast 'n Hold' mode. Overloading of oven. Electrical supply incorrect. Fan not working. Thermostat out of calibration. <b>(Refer fault diagnosis 6.1.11)</b> Element not working.	Switch off 'Roast 'n Hold'. Reduce oven loading. Check supply voltage is as per rating plate voltage. Check fan operation. Correct calibration. <b>(Refer service section 6.4.1)</b> Correct element fault. <b>(Refer Fault: No Heat)</b>
ELEMENT NOT WORKING	Element faulty (blown). <b>(Refer fault diagnosis 6.1.9)</b>	Replace. <b>(Refer service section 6.3.15)</b>
NO THERMOSTAT HEATING INDICATOR	Indicator faulty. <b>(Refer fault diagnosis 6.1.12)</b>	Replace. <b>(Refer service section 6.3.3)</b>
ROAST TIMER (180 MINUTE) WILL NOT TIME DOWN	Roast 'n' Hold switch not depressed. No power to timer / timer faulty.. <b>(Refer fault diagnosis 6.1.13)</b> 'Roast 'n Hold' switch faulty. <b>(Refer fault diagnosis 6.1.13)</b>	Depress switch. Switch will illuminate. Correct electrical fault / replace timer. <b>(Refer service section 6.3.8)</b> Replace. <b>(Refer service section 6.3.4)</b>
NO HOLD INDICATOR	Faulty indicator. <b>(Refer fault diagnosis 6.1.14)</b> Faulty timer. <b>(Refer fault diagnosis 6.1.14)</b>	Replace. <b>(Refer service section 6.3.3)</b> Replace. <b>(Refer service section 6.3.8)</b>
HOLDING TEMPERATURE INCORRECT	Hold thermostat set temperature incorrect. Hold thermostat faulty. <b>(Refer fault diagnosis 6.1.15)</b>	Adjust to correct temperature. <b>(Refer service section 6.4.5)</b> Replace. <b>(Refer service section 6.3.10)</b>
DOOR DOES NOT CLOSE	Tray in way of door. Door seal obstruction. Door handle installed incorrectly. Door catch setting incorrect. Door pivot bushes / pins worn.	Correctly position tray in rack. Correctly install door seal. <b>(Refer service section 6.3.22)</b> Ensure handle is fitted correctly. Adjust. <b>(Refer service section 6.4.3)</b> Replace. <b>(Refer service section 6.3.23)</b>



FAULT	POSSIBLE CAUSE	REMEDY
DOOR SEAL LEAKS	Door seal damaged.	Replace. <b>(Refer service section 6.3.22)</b>
	Door seal incorrectly fitted.	Correctly install door seal. <b>(Refer service section 6.3.22)</b>
	Door catch setting incorrect.	Adjust. <b>(Refer service section 6.4.3)</b>
	Door pivot bushes / pins worn.	Replace. <b>(Refer service section 6.3.23)</b>
	Door catch striker plate worn.	Replace.

## 6. SERVICE PROCEDURES

 **WARNING:** ENSURE POWER SUPPLY IS SWITCHED OFF BEFORE SERVICING.

 **WARNING:** ALL INSTALLATION AND SERVICE REPAIR WORK MUST BE CARRIED OUT BY QUALIFIED PERSONS ONLY.

SECTION	PAGE NO.
<b>6.1 FAULT DIAGNOSIS</b> .....	<b>21</b>
6.1.1 Oven Does Not Operate / Start .....	21
6.1.2 Fan Does Not Operate .....	21
6.1.3 Oven Light Not Illuminating—Door Open .....	22
6.1.4 Oven Light Not Illuminating—Door Closed .....	22
6.1.5 No Water Injection / Steam.....	22
6.1.6 Continuous Water Out Of Oven Water Nozzle .....	22
6.1.7 60 Minute Timer No Time Up Buzzer .....	22
6.1.8 60 Minute Timer No Time Up Indicator.....	23
6.1.9 No Heat .....	23
6.1.10 No Temperature Control (Temperature Overrun).....	24
6.1.11 Slow Recovery.....	24
6.1.12 No Thermostat Heating Indicator.....	24
6.1.13 Roast Timer (180 Minute) Will Not Time Down .....	24
6.1.14 No Hold Indicator.....	25
6.1.15 Holding Temperature Incorrect.....	25
<b>6.2 ACCESS</b> .....	<b>26</b>
6.2.1 Control Panel.....	26
6.2.2 Service Panel (Side Panel).....	26
6.2.3 Control Panel (Rear).....	26
<b>6.3 REPLACEMENT</b> .....	<b>27</b>
6.3.1 Light Bulb / Glass .....	27
6.3.2 Door Microswitch .....	27
6.3.3 Neon Indicator .....	27
6.3.4 Power / Roast / Lights / Water Switches .....	27
6.3.5 Buzzer .....	27
6.3.6 Hold Relay .....	28
6.3.7 Bake Timer .....	28
6.3.8 Roast Timer .....	28
6.3.9 Thermostat .....	28
6.3.10 Hold Thermostat .....	29
6.3.11 Heating Contactor.....	29
6.3.12 Water Solenoid .....	29
6.3.13 Water Solenoid Cleaning.....	30
6.3.14 Spray Nozzle .....	30
6.3.15 Elements.....	30
6.3.16 Fan .....	30
6.3.17 Motor .....	31
6.3.18 Motor Timer .....	31
6.3.19 Motor Capacitor .....	31
6.3.20 Outer Glass .....	31

---

6.3.21	Inner Glass .....	32
6.3.22	Door Seals.....	32
6.3.23	Door Pivot Bushes.....	32
6.3.24	Stainless Steel Door—Outer Glass .....	33
6.3.25	Stainless Steel Door—Inner Glass .....	33
<b>6.4</b>	<b>ADJUSTMENT / CALIBRATION .....</b>	<b>34</b>
6.4.1	Thermostat Calibration .....	34
6.4.2	Door Microswitch Adjustment .....	34
6.4.3	Reversing the Door.....	34
6.4.4	Door Roller Catch Adjustment .....	35
6.4.5	Door Alignment.....	35
6.4.6	Hold Temperature Adjustment.....	35
6.4.7	60 Minute Timer Zero Position Adjustment .....	35

---

## 6.1 FAULT DIAGNOSIS

---

### 6.1.1 OVEN DOES NOT OPERATE / START

---

#### Incorrect electrical supply

Check that the voltage across phase and neutral (L1 and L2) terminals of terminal block is the voltage as stated on the unit's electrical rating plate.

If incorrect, check electrical connection of supply wiring and / or check electrical supply.

#### Power switch faulty

Check if power switch latches. If the switch does not latch, then switch is faulty—replace.

With switch latched, check voltage across terminal one to terminal three or four. If there is no voltage, check for fault in wiring.

Check voltage across terminal two to terminal three or four. If there is no voltage, then switch is faulty—replace.

**NOTE:** When power switch is latched, it should illuminate if operating correctly.

---

### 6.1.2 FAN DOESN'T OPERATE

---

#### Microswitch out of adjustment

Open oven door and manually depress door microswitch actuator at top right of oven. If this activates the fan, then the microswitch actuator arm inside control cavity requires adjustment.

#### Microswitch faulty

Check voltage from microswitch terminals to neutral.

With the door closed there should be power to the com terminal and the n.o. terminal.

With the door open there should be power to the com terminal and the n.c. terminal.

If not, microswitch is faulty—replace.

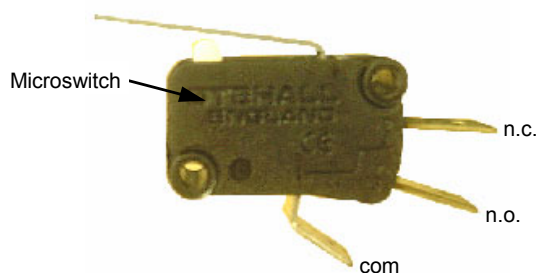

Figure 6.1.1

#### Fan motor timer faulty

With oven switched on, and door closed, ensure that the cams on the motor timer are rotating.

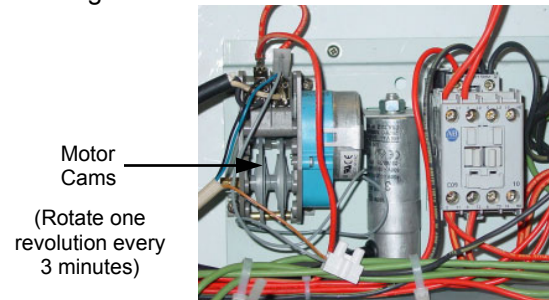

Figure 6.1.2

If cams are rotating, then isolate the power supply from the oven. Remove the bottom wire from the left hand switch terminals. Rotate the cams manually whilst testing for continuity through the left hand switch. Check that the continuity cycles as the cams are rotated. Re-secure the left hand wire, and then repeat test for right hand switch.

When operating, 50Hz models should cycle the power for approximately 80 seconds through each switch, with a 10 second delay between each cycle.

On 60Hz models the power should cycle for approximately 65 seconds through each switch, with an 8 second delay between each cycle.

If there is no continuity, or the continuity does not cycle correctly then timer is faulty - replace.

#### Fan motor capacitor faulty

Ensure that oven is isolated from the power supply. Disconnect the two capacitor wires. Briefly short across the capacitor terminals, to ensure that it is fully discharged.

Using a multimeter, measure the resistance across capacitor terminals.

The resistance should start low and quickly increase to infinity within 5-10 seconds. If the resistance does not increase at all, then the capacitor is shorted - replace. If the capacitor is infinite resistance straight away then it is open-circuit - replace. If the resistance never goes very high then the capacitor is leaky - replace.

---

### 6.1.3 OVEN LIGHTS NOT ILLUMINATING - DOOR OPEN (AUTOMATICALLY ON)

---

#### No power to lights

Check the supply voltage across lamp housing terminals at RH side rear of oven. If the voltage is correct, replace the bulb (if faulty). If the bulb is OK, check lamp housing. Replace if faulty.

If there is no voltage, open oven door and manually depress door microswitch actuator at bottom right of oven. If this activates the lights, then the microswitch actuator arm behind the control panel requires adjustment.

Check voltage across micro-switch terminals to neutral.

With the door open there should be power to the com terminal and the n.c. terminal.

If not, microswitch is faulty—replace.

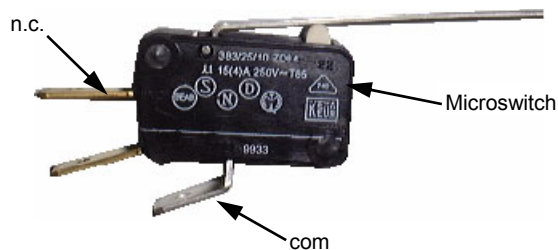

Figure 6.1.3

---

### 6.1.4 OVEN LIGHTS NOT ILLUMINATING - DOOR CLOSED (MANUALLY SWITCHED ON)

---

#### Light switch faulty

Check voltage to the bottom terminal of the switch. If there is no voltage, then check wiring.

With switch depressed, check voltage at top terminal. If there is no voltage, then replace the switch.

If voltage is correct, then check wiring to light.

**NOTE:** Alternately, perform a continuity test across the terminals with the light switch depressed.

---

### 6.1.5 NO WATER INJECTION / STEAM

---

#### Fault with water valve

Check voltage supply across the water valve solenoid coil with the steam switch depressed. If there is no power supply then check the control panel steam switch.

Check voltage to the bottom terminal of the switch. If there is no voltage, then check wiring.

With switch depressed, check for voltage at top terminal. If there is no voltage then replace switch. If voltage correct, check wiring to solenoid coil.

If power supply to the coil is correct, disconnect wiring to coil and check the resistance of the coil windings.

Correct coil resistance: 3650 ohms

**NOTE:** If open circuit / high resistance, then the coil is faulty—replace.

If coil resistance is correct, rewire and listen for an audible solenoid click when the steam switch is depressed.

If solenoid can be heard functioning, and oven water nozzle is not blocked, then remove water solenoid and fittings and check for blockages.

---

### 6.1.6 CONTINUOUS WATER OUT OF OVEN WATER NOZZLE

---

#### Water solenoid electrical fault

With control panel steam switch not depressed, check for power supply across solenoid coil. If there is power to the coil, then check wiring and steam switch (refer 6.1.5).

---

### 6.1.7 60 MINUTE TIMER NO TIME UP BUZZER

---

#### Buzzer faulty

With timer in 'zero' position, check the buzzer at side of control panel (inside) for voltage across terminals. If voltage is correct then buzzer is faulty—replace.

If there is no voltage, then check wiring.

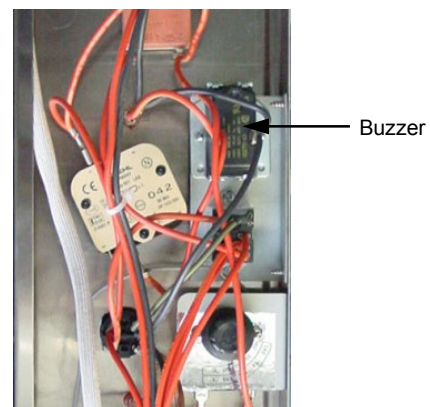

Figure 6.1.4

### Timer not switching on buzzer

With timer in zero position, check voltage to top connection (terminal one) and bottom connection (terminal two) of timer. If there is no voltage at terminal one then check wiring.

If no voltage at terminal two then timer is faulty—replace.

**NOTE:** Timer will continue to run approximately three minutes below zero. Buzzer and time up indicator will continue until the timer is manually switched off (to vertical position).

### 6.1.8 60 MINUTE TIMER NO TIME UP INDICATOR

#### Indicator faulty

With the timer in the zero position, check for voltage across the indicator light. If correct, then the indicator light is faulty—replace.

If there is no voltage then check wiring.

### 6.1.9 NO HEAT

#### No power to thermostat

Check voltage to terminal 2 on oven thermostat. If there is no voltage then check voltage through terminal 5 and one on hold relay (behind control panel). If there is no voltage to terminal 5 then check wiring. If there is no voltage to terminal 1 then check that the hold relay has no power at relay coil terminal 7. If relay coil is not energised (ie no power at 7) and no power out of terminal 1, then the relay is faulty—replace.

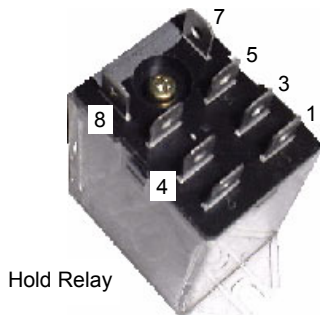

Figure 6.1.5

If relay is energised (ie power at 7) then 'Roast n Hold' switch is on and unit is in hold mode. Turn off 'Roast n Hold' and recheck operation.

**NOTE:** There should be no voltage across these terminals when 'Roast n Hold' is not selected.

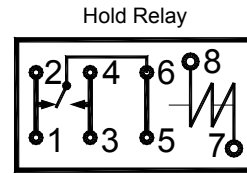

Figure 6.1.6

#### Thermostat faulty

Set thermostat to 200°C or 400°F. Check the voltage out of terminal 1 on the thermostat. If there is no voltage then the thermostat is faulty—replace.

If the voltage is correct and the heating light is on then check all wiring to heating contactor.

#### Heating contactor faulty

With thermostat on, check that the heating contactor coil has power to terminal A1 and voltage across the coil, terminals A1 and A2. If incorrect check wiring.

If voltage is correct, check that contactor pulls in and closes the contacts when power to contactor coil is on. Correct operation will make an audible noise when closing contacts and on the front face of the contactor the contact mechanism will visibly pull in. If not, contactor is faulty—replace.

If contactor operates correctly, check for continuity through the poles of the contactor when closed. If no continuity through connected poles then contacts are blown and contactor requires replacing.

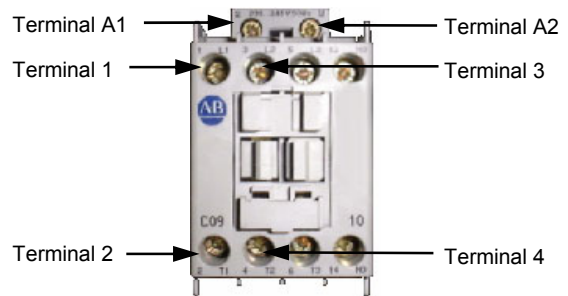

Figure 6.1.7

For checking elements where temperature overrun is occurring, check that contactor releases (opens) when thermostat is switched OFF. If not, contacts of the contactor have welded shut and elements will be ON and heating will be continuous. Contactor is faulty—replace.

---

### Element faulty (blown)

With the thermostat on and heating check voltage across element terminals at RH side of oven. If the voltage is correct then check the current draw of element. If there is no current draw then element is faulty—replace.

If there is no voltage then check voltage is being supplied to each element coil from the heating contactor. If no voltage to elements, check contactor operation (refer 6.1.9) and wiring.

**NOTE:** Correct element current draw:

208 V : Inner Coil	12.9A ± 2.5%
Outer Coil	15.0A ± 2.5%
220 V : Inner Coil	13.6A ± 2.5%
Outer Coil	15.9A ± 2.5%
240 V : Inner Coil	12.5A ± 2.5%
Outer Coil	14.6A ± 2.5%

---

### 6.1.10 NO TEMPERATURE CONTROL (TEMPERATURE OVERRUN)

---

#### Heating contactor faulty

Refer 6.1.9

#### Thermostat faulty

With thermostat in off (vertical) position, the heating indicator should be off. If not then the thermostat is faulty—replace.

---

### 6.1.11 SLOW RECOVERY

---

#### Thermostat out of calibration

Place an accurate digital thermometer probe in centre of oven. Set thermostat to 180°C or 355°F. Close the oven door and allow oven thermostat to cycle on and off twice. Record oven centre temperature for the next thermostat on and off cycle. The thermostat should cycle on and off between 165°C and 195°C or 330°F and 385°F when set to the above temperature. If oven temperature is outside these ranges, then the thermostat requires recalibration.

**NOTE:** Thermostat cycling span should be ±15°C or 27°F

---

### 6.1.12 NO THERMOSTAT HEATING INDICATOR

---

#### Indicator faulty

Check the voltage across the indicator terminals. If the voltage is correct then the indicator is faulty—replace.

If there is no voltage then check wiring.

---

### 6.1.13 ROAST TIMER (180 MINUTE) WILL NOT TIME DOWN

---

#### No power to timer

Check the voltage at terminal 5 on underside of the 180 minute timer.

Check that one lead of timer motor is connected to terminal five of timer and the other lead is connected to neutral of 'Roast 'n Hold' switch.

If voltage at terminal 5 is correct and wiring is correct then the timer motor is faulty—replace timer.

If there is no power at terminal 5, check for power supply at terminal 4 of timer. If there is voltage at terminal 4 and not at terminal 6 with timer set, then timer switch is faulty—replace timer.

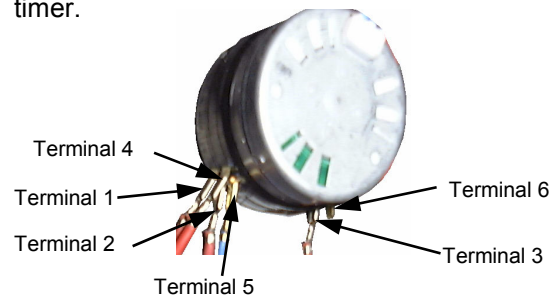

Figure 6.1.8

If terminal 4 voltage is correct, check relay at the base of the control housing behind control panel is latched ON. If relay is ON then check wiring.

If relay is not latched ON when 'Roast 'n Hold' switch illuminated then check the voltage across terminals 7 and 8 of relay coil (fig 6.1.5). If the voltage is correct but the relay is in the off position then the relay is faulty—replace.

If there is no voltage across 7 and 8 then check wiring.

---

**'Roast 'n Hold' switch faulty**

Check if the switch latches. If the switch does not latch then the switch is faulty—replace.

With the switch latched, check voltage across terminal 1 to terminal 3 or 4. If there is no voltage then check for fault in wiring.

Check voltage across terminal 2 to terminal 3 or 4. If there is no voltage then switch is faulty—replace.

**NOTE:** When the switch is latched, it should illuminate if operating correctly.

If the voltage is correct, and the thermostat is adjusted above oven temperature, then check for output voltage at terminal 1 (bottom) of hold thermostat. If there is no voltage and the hold thermostat will not switch on then the thermostat is faulty—replace.

If the voltage is correct but the element is not working then check wiring.

---

**6.1.14 NO HOLD INDICATOR**

---

**Indicator faulty**

Check the voltage across the indicator terminals. If the voltage is correct then the indicator is faulty—replace.

If there is no voltage then check wiring.

**Timer faulty**

**NOTE:** Timer in 'HOLD' position (vertical) and 'Roast n Hold' switch on (illuminated).

Check the voltage at terminal three of timer, with timer in hold position. If the voltage is correct then check wiring.

If there is no voltage then check voltage at terminal one of timer. If there is voltage at terminal one, but no voltage at terminal three with timer in hold position then timer switch is faulty—replace.

---

**6.1.15 HOLDING TEMPERATURE INCORRECT**

---

**Hold thermostat faulty**

With the power switch on and illuminated, 'Roast 'n Hold' switch on and illuminated, and the roast (180 minute) timer set to hold, check that the hold indicator is illuminated.

With a cold oven (ie room temperature) check that the oven element is heating. Test the voltage across the element terminals at the RH side of oven. If the voltage is correct then refer Fault: No heat (trouble shooting section).

If there is no voltage at the element terminals, check the voltage at terminal 2 of the hold thermostat at RH side of control panel (fig 6.3.12). If there is no voltage then check wiring.



## 6.2 ACCESS

### 6.2.1 CONTROL PANEL

- 1) Undo the two screws at the bottom of the control panel.



Figure 6.2.1

- 2) The panel can now be removed.  
When closing the panel ensure wires and thermostat capillary tubes are clear of metal or other terminals.

### 6.2.2 SERVICE (SIDE) PANEL

- 1) Undo the four screws holding the panel.



Figure 6.2.2

- 2) Remove side panel.

### 6.2.3 CONTROL PANEL—REAR

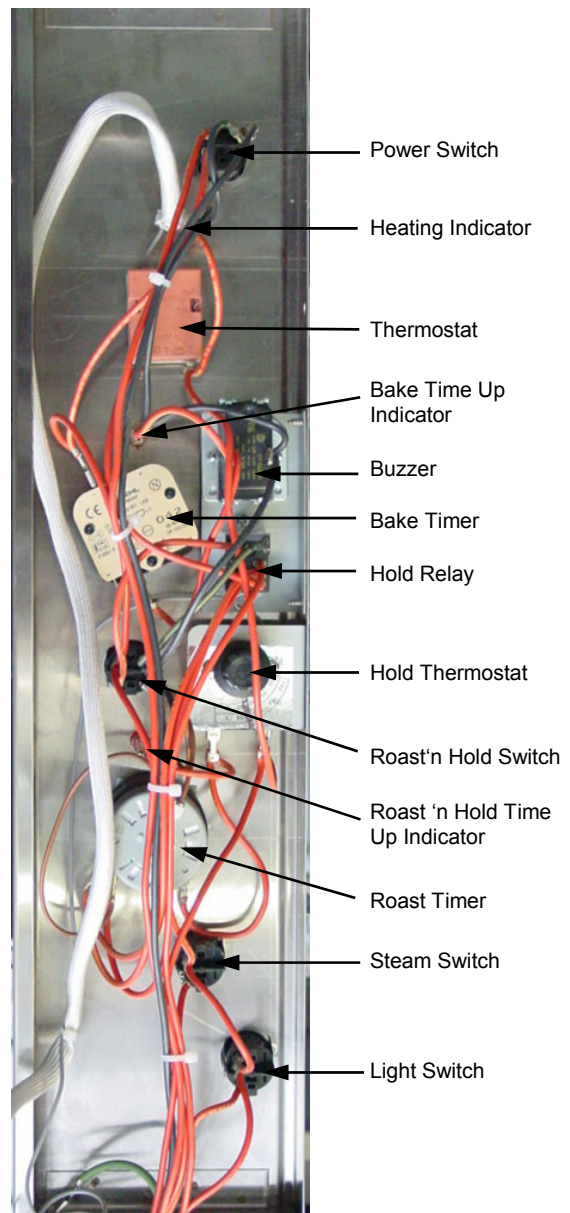

Figure 6.2.3

---

## 6.3 REPLACEMENT

---

### 6.3.1 LIGHT BULB / GLASS

---

- 1) Unscrew lamp cover(s).

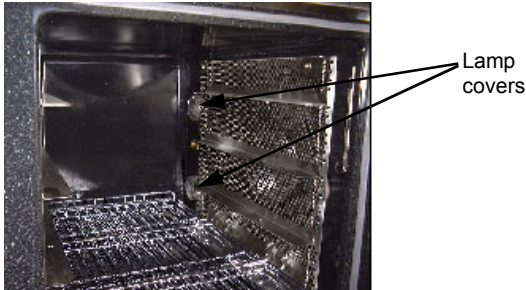

Figure 6.3.1

- 2) Unscrew bulb out of fitting.
- 3) Screw in replacement bulb.
- 4) Ensure seal fitted. Screw lamp cover into holder with baffle fitted (do not over tighten).

---

### 6.3.2 DOOR MICROSWITCH

---

- 1) Remove control panel (refer 6.2.1)
- 2) Remove two screws holding microswitch to bracket.

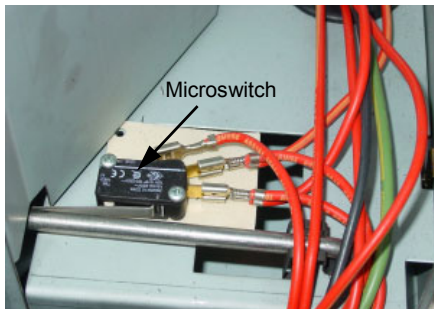

Figure 6.3.2

- 3) Transfer wires to the new switch and reassemble.
- 4) Adjust micro-switch (refer 6.4.2).

---

### 6.3.3 NEON INDICATOR

---

- 1) With control panel open (refer 6.2.1) remove the wires from the back of the neon.

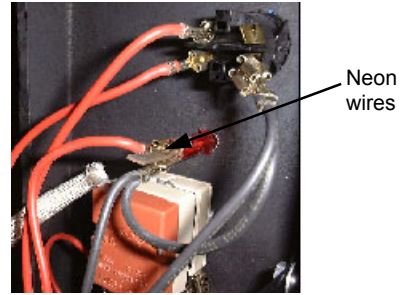

Figure 6.3.3

- 2) From back push neon through front of panel rotating clockwise.
- 3) Push new neon in from front of panel, and reconnect wires.

---

### 6.3.4 POWER / ROAST / LIGHTS / STEAM SWITCHES

---

- 1) With control panel open (refer 6.2.1) remove the wires from the back of the switch, noting their positions.

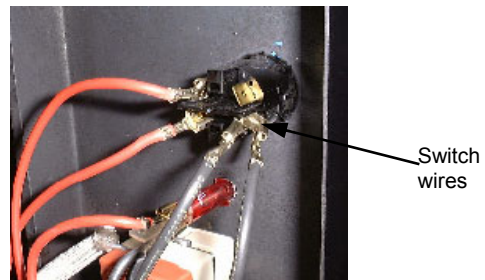

Figure 6.3.4

- 2) From back push switch through front of panel.
- 3) Push new switch in from front of panel, and reconnect wires.

---

### 6.3.5 BUZZER

---

- 1) Remove control panel (refer 6.2.1).
- 2) Remove two screws holding buzzer / relay bracket to control panel.

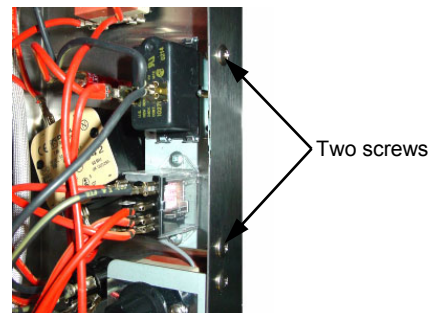

Figure 6.3.5

- 3) Withdraw and remove two screws holding buzzer to bracket.
- 4) Transfer wires to new buzzer.
- 5) Reassemble in reverse order.

---

### 6.3.6 HOLD RELAY

---

- 1) Open control panel (refer 6.2.1).
- 2) Remove two screws securing the relay to the buzzer / relay bracket on the control panel.

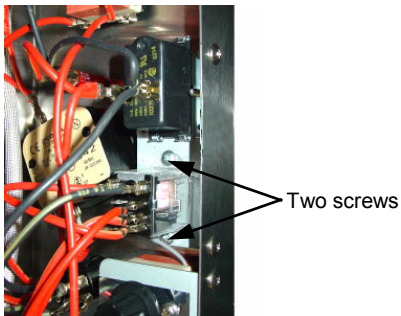

Figure 6.3.6

- 3) Withdraw and transfer wires to new relay.
- 4) Reassemble in reverse order.

---

### 6.3.7 BAKE TIMER

---

- 1) Remove bake timer knob by pulling it firmly away from control panel.
- 2) Open control panel (refer 6.2.1) and undo two screws securing timer.



Figure 6.3.7

- 3) Transfer wires to new timer.
- 4) Withdraw old timer and insert new timer, securing with screws.
- 5) Replace knob.

---

### 6.3.8 ROAST TIMER

---

- 1) Remove roast timer knob by pulling it firmly away from control panel.
- 2) Open control panel (refer 6.2.1) and undo two screws securing timer.

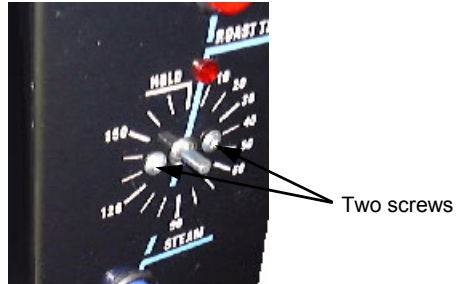

Figure 6.3.8

- 3) Transfer wires to new timer.
- 4) Withdraw old timer and insert new timer, securing with screws.
- 5) Replace knob.

---

### 6.3.9 THERMOSTAT

---

- 1) Pull knob off front of thermostat
- 2) Open control panel (refer 6.2.1) and undo two screws securing thermostat.

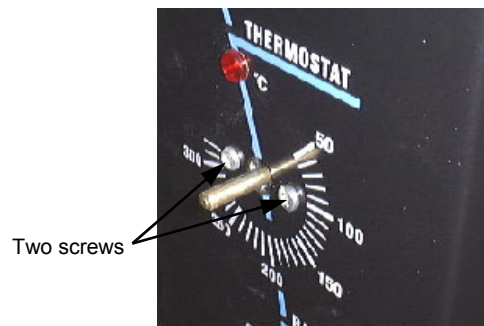

Figure 6.3.9

- 3) Transfer wires to new thermostat.
- 4) Open oven door, remove racks and fan baffle rack. Loosen two screws securing thermostat phial bracket.

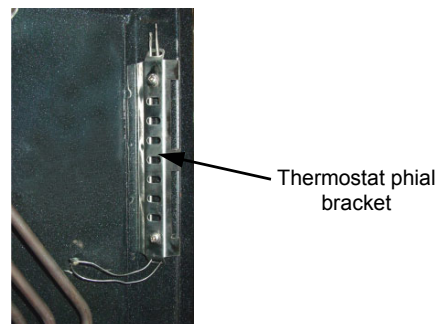

Figure 6.3.10

- 5) Withdraw old thermostat phial through side of oven. Note position in phial bracket.
- 6) Insert new thermostat.
- 7) Re-assemble in reverse order.

**NOTE:** Ensure that the thermostat phials are located in their correct positions. The main thermostat probe must be on the side closest to the door. The hold thermostat must be on the side closest to the fan and elements.

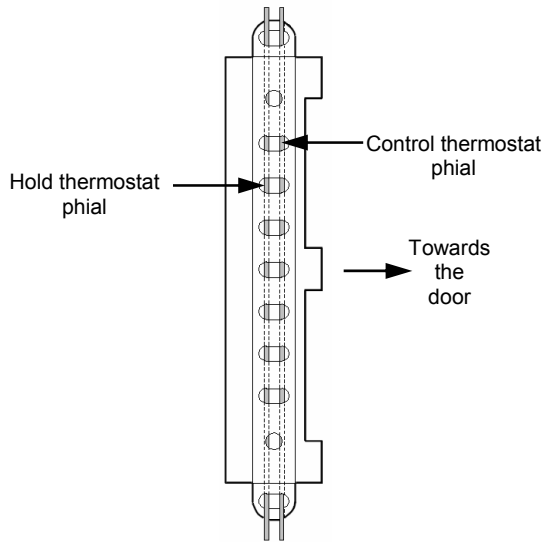

Figure 6.3.11

### 6.3.10 HOLD THERMOSTAT

- 1) Open control panel (refer 6.2.1) and undo two screws securing hold thermostat bracket.

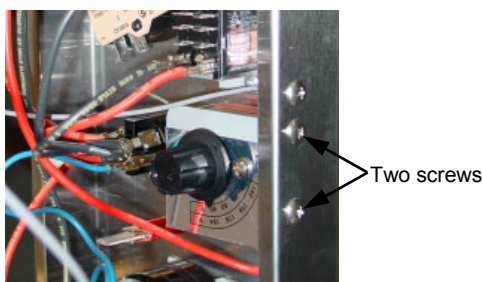

Figure 6.3.12

- 2) Remove the two screws securing the hold thermostat to the bracket, and then fit the new thermostat in its place.
- 3) Transfer wires to new thermostat.
- 3) Open oven door, remove racks and fan baffle rack. Loosen the thermostat phial bracket (refer figure 6.3.10).

- 4) Withdraw the old hold thermostat phial through the side of the oven. Note the position of the phial in the bracket.
- 5) Insert new thermostat phial.
- 6) Re-assemble in reverse order.

**NOTE:** Ensure that the thermostat phials are located in their correct positions. The main thermostat probe must be on the side closest to the door. The hold thermostat must be on the side closest to the fan and elements.

### 6.3.11 HEATING CONTACTOR

- 1) Remove the right hand service panel (refer 6.2.2).
- 2) Unclip contactor from the gear plate.

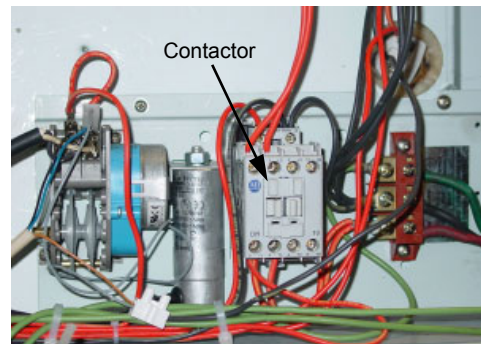

Figure 6.3.13

- 3) Clip new contactor onto gear plate.
- 4) Transfer wires from old contactor to new contactor, ensuring all wires are in their correct positions.

### 6.3.12 WATER SOLENOID

- 1) Ensure water supply is turned off.
- 2) To access the solenoid, remove the right hand service panel (refer 6.2.2)
- 3) Disconnect all water connections from the water solenoid.
- 4) Remove water solenoid from oven by removing two screws securing the water solenoid to its mounting bracket.

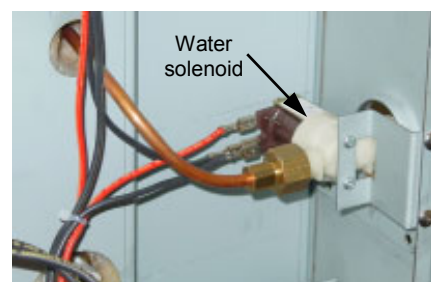

Figure 6.3.14

- 5) Carefully withdraw solenoid.
- 6) Replace or service solenoid as required.
- 7) To reinstall, reverse procedure.
- 8) Check water connections do not leak.
- 9) Check for correct operation of the oven water injection.

### 6.3.13 WATER SOLENOID CLEANING

- 1) Disconnect water supply from the water solenoid.
- 2) Remove the sieve from the water valve assembly by pulling firmly away from the assembly with a pair of pliers.



Figure 6.3.15

- 4) Clean the sieve, removing all dirt and grime.
- 5) Replace the sieve and reconnect the water supply.

### 6.3.14 SPRAY NOZZLE

- 1) Inside the oven remove the RH side fan baffle, then unscrew the spray nozzle.

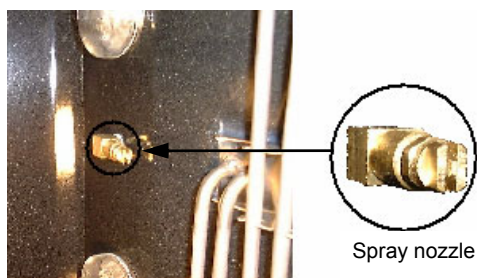

Figure 6.3.16

- 2) Clean or replace as required, ensuring debris free on re-assembly.
- 3) Ensure that the spray nozzle is installed in the vertical position.

### 6.3.15 ELEMENTS

- 1) Remove service panel (refer 6.2.2) and baffle.
- 2) Remove the wires from the elements.

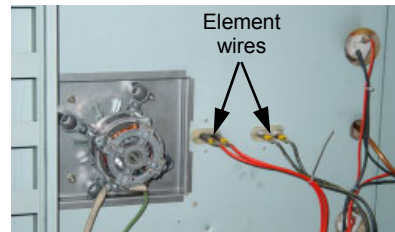

Figure 6.3.17

- 3) Unscrew the elements from inside the oven.

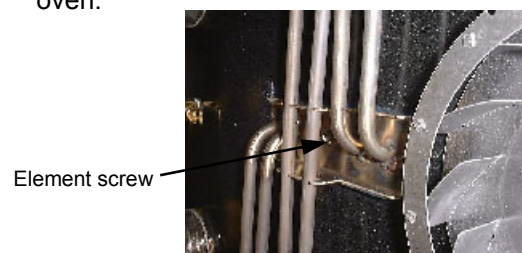

Figure 6.3.18

- 4) Pull elements carefully to remove. Silicone sealant may require effort to remove elements.
- 5) Replace and re-assemble in reverse order. Use high temperature (232°C / 450°F minimum) RTV silicone sealant to seal element against side wall of oven.

Element Rating:

208-220 V	Inner Element	17.0 ohms
	Outer Element	14.1 ohms
230-240 V	Inner Element	19.4 ohms
	Outer Element	17.0 ohms

### 6.3.16 FAN

- 1) With baffle removed undo the grub screw securing the fan to the motor shaft.

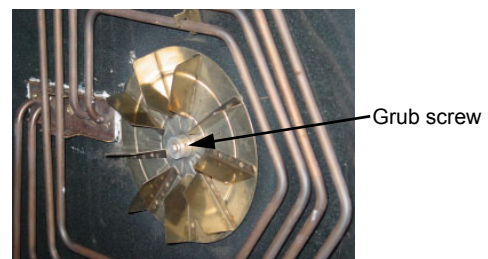

Figure 6.3.19

- 2) Remove the fan from the shaft, replace, and reassemble.

---

### 6.3.17 MOTOR

---

- 1) Remove fan (refer 6.2.16).
- 2) Remove the right hand service panel and then remove the motor wires.
- 3) Undo the four screws holding the motor in place (from inside the oven) and remove motor.

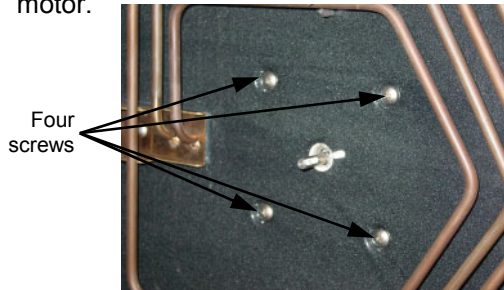

Figure 6.3.20

- 4) Replace motor and reassemble in reverse order.

---

### 6.3.18 MOTOR TIMER

---

- 1) Remove the right hand service panel (refer 6.2.2).
- 2) Remove the screws securing the motor timer to the gear plate.

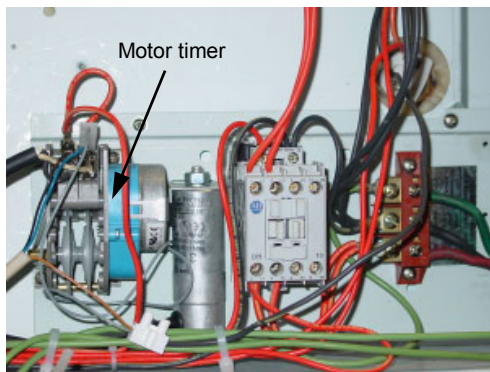

Figure 6.3.21

- 3) Fit the new timer to the gear plate, and transfer the wires from the old timer.

---

### 6.3.19 MOTOR CAPACITOR

---

- 1) Remove the right hand service panel (refer 6.2.2).
- 2) Undo the nut securing the capacitor to the mounting bracket.

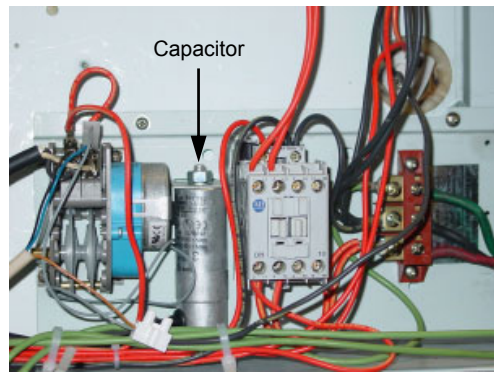

Figure 6.3.22

- 3) Remove the capacitor wires, noting their positions.
- 4) Fit new capacitor and reassemble in reverse order.

---

### 6.3.20 OUTER GLASS

---

- 1) Open door.
- 2) Loosen the two screws securing the bottom pivot whilst supporting the door. The pivot can now be lowered, and the door removed from the oven.

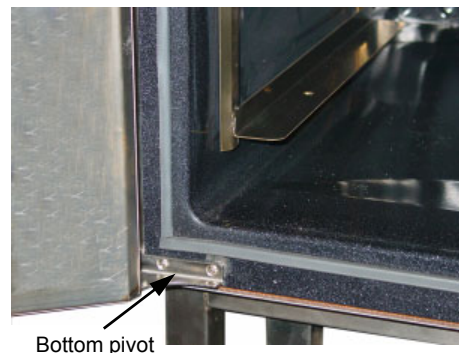

Figure 6.3.23

- 3) Remove screws securing door handle, and remove the handle from the door assembly.

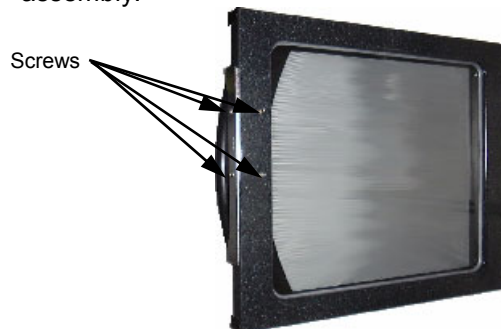

Figure 6.3.24

- Remove four screws in top trim and four screws in bottom trim of door, and remove trim panels.

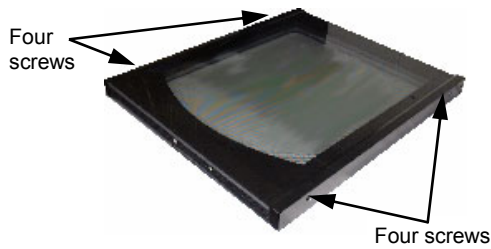

Figure 6.3.25

- Lift outer glass away from door.
- To replace, ensure that the two silicone rubber seals are in place on the left hand and right hand side of the door frame. Clean the inside of the glass and refit it, ensuring that the silicone rubber seals cover the outer edges of the glass. Refit the trim panels.

### 6.3.21 INNER GLASS

- Remove the outer glass (refer 6.3.20). Uncrimp the retaining lugs of the window spacer and remove the spacer and glass.



Figure 6.3.26

- To replace, ensure the silicone rubber seal has not been displaced. Clean the glass and refit it. Place the window spacer in position and crimp the retaining lugs over to hold the glass in place. Refit outer glass as above.

### 6.3.22 DOOR SEALS

- Open oven door.
- To remove, hold at their centre point and pull forward until they unclip

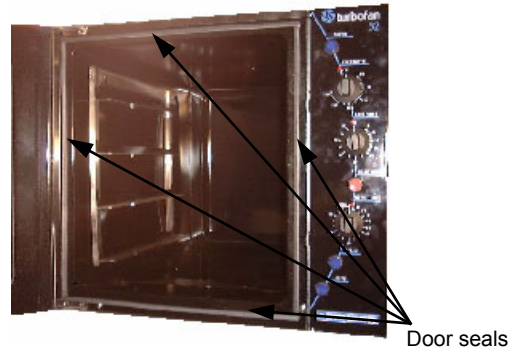

Figure 6.3.27

- Refit new seals.

**Note:** Fit top and bottom seals first, with open side of seal facing downwards. Fit side seals with open side facing outwards.

### 6.3.23 DOOR PIVOT BUSHES

- Remove door as per steps one and two of section 6.3.18.
- Remove the top and bottom pivot brackets (two screws).

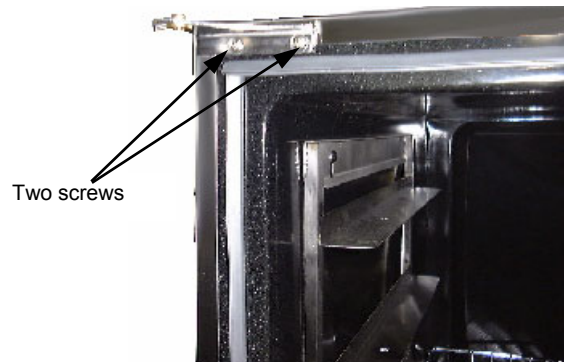

Figure 6.3.28

- Door bushes can now be removed and replaced.



Figure 6.3.29

- Reinstall door by reversing steps one to two of section 6.3.18.

---

### 6.3.24 STAINLESS STEEL DOOR - OUTER GLASS

---

- 1) Remove the door as per steps one and two of section 6.3.20.
- 2) Remove the top and bottom pivots (two screws each), and the door handle and roller catches (two screws top and bottom).



Figure 6.3.30

- 3) Replace with new glass.  
Ensure when replacing that the side with the 'L' mark is inside the door (not inside the oven). This ensures the correct operation of the 'Low E' glass.
- 4) Reassemble and refit door to the oven.

- 3) The stainless steel door outer can now be removed.
- 4) To replace the outer glass, simply remove and replace, taking care that the outer seals are positioned correctly around the glass edge.

Ensure when replacing that the side with the 'L' mark is inside the door (not on the front of the oven). This ensures the correct operation of the 'Low E' glass.

- 5) Reassemble in reverse order and refit door to oven.

---

### 6.3.25 STAINLESS STEEL DOOR - INNER GLASS

---

- 1) Remove the outer glass (refer 6.3.24).
- 2) Uncrimp the retaining angles and remove inner glass.

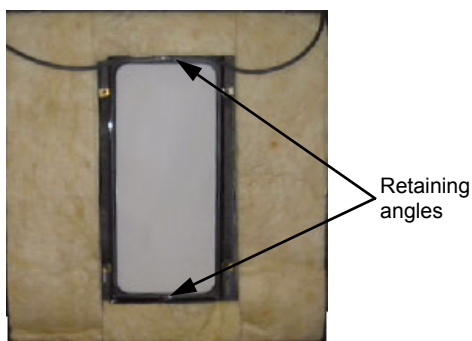

Figure 6.3.31



## 6.4 ADJUSTMENT / CALIBRATION

### 6.4.1 THERMOSTAT CALIBRATION

**! IMPORTANT:** IF THE OVEN TEMPERATURE NEEDS TO BE INCREASED, ENSURE THAT THE THERMOSTAT IS IN THE 'OFF' POSITION BEFORE CARRYING OUT ADJUSTMENT. IF OVEN TEMPERATURE NEEDS TO BE DECREASED, ENSURE THERMOSTAT IS IN THE MAXIMUM TEMPERATURE POSITION BEFORE CARRYING OUT ANY ADJUSTMENT.

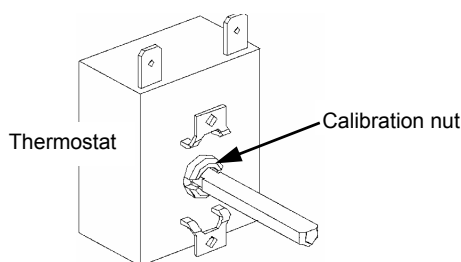

Figure 6.4.1

- 1) Remove thermostat knob by pulling it firmly away from control panel.
- 2) Adjust the calibration nut located at the base of the thermostat shaft.

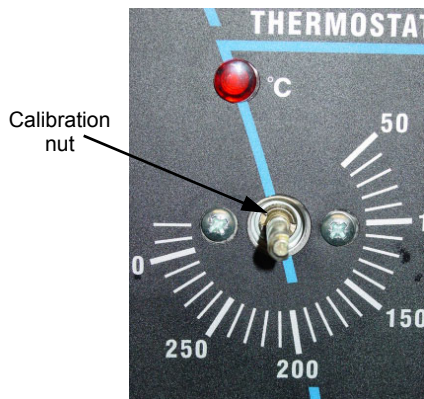

Figure 6.4.2

To increase oven temperature, turn the calibration nut anticlockwise.  
To decrease oven temperature, turn the calibration nut clockwise.  
Adjustment of the calibration nut by 1° angular will alter oven temperature by approximately 2°C (3.6°F).

- 3) Refit the knob to the thermostat.
- 4) Recheck the oven thermostat calibration.
- 5) Repeat procedure if necessary.

### 6.4.2 DOOR MICROSWITCH ADJUSTMENT

- 1) Open oven door.
- 2) Open control panel (refer 6.2.1).
- 3) With fingers, bend actuator arm of microswitch so that switch operates when door is in closed position.

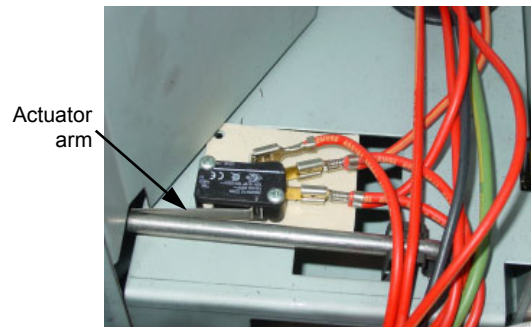

Figure 6.4.3

### 6.4.3 REVERSING THE DOOR

If desired, a left hand hinged oven door can be changed to a right hand hinged door (or vice versa).

- 1) While supporting the door, undo the door hinges from the oven. Remove the door.
- 2) The bottom right door catch plate should now be transferred to the top left of the oven (a), and the top right door catch plate transferred to the bottom left of the oven (b).

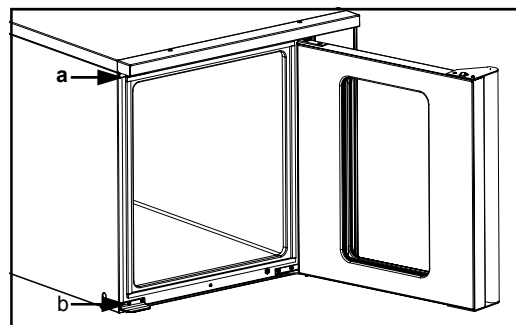

Figure 6.4.4

- 3) Secure the door hinges and oven door to the right hand side of the oven door opening.
- 4) If alignment of the door is necessary, the five screws along the bottom of the oven can be loosened, and the door moved a small amount to ensure that it is square with the oven. Tighten the screws when the correct door position is attained.

- 5) If necessary the roller catches can be removed from the door (after removing handle on stainless steel doors) to adjust height settings for correction of door catch operation.

#### 6.4.4 DOOR ROLLER CATCH ADJUSTMENT

- 1) Open the door.
- 2) Remove the two screws securing the roller catch to the door and withdraw the catch.
- 3) Tighten or loosen the nuts on the catch assembly to adjust the height of the roller.

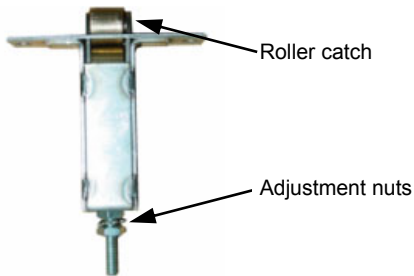

Figure 6.4.5

- 4) Refit catch to door and check operation. Adjust again if necessary.

#### 6.4.5 DOOR ALIGNMENT

- 1) Loosen the five screws along the bottom edge of the oven front.

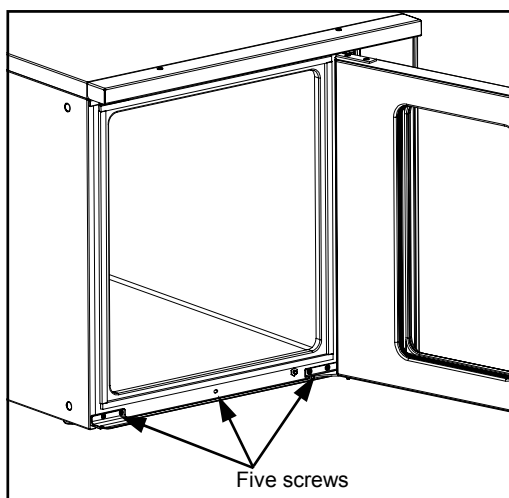

Figure 6.4.6

- 2) Adjust the door position to ensure that it is square with the oven. Tighten the screws.

#### 6.4.6 HOLD TEMPERATURE ADJUSTMENT

- 1) Open control panel (refer 6.2.1) to gain access to the hold thermostat (located inside the control panel).
- 2) The hold temperature of the oven can be adjusted by turning the hold thermostat dial to the desired hold temperature.

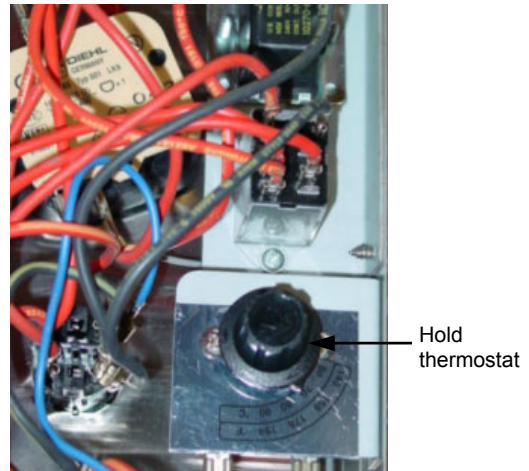

Figure 6.4.7

#### 6.4.7 60 MINUTE TIMER ZERO POSITION ADJUSTMENT

- 1) Remove 60 minute timer knob by pulling it firmly away from control panel.
- 2) Open control panel (refer 6.2.1). Loosen two screws on control panel holding 60 minute timer.

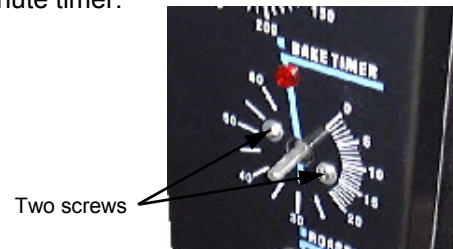
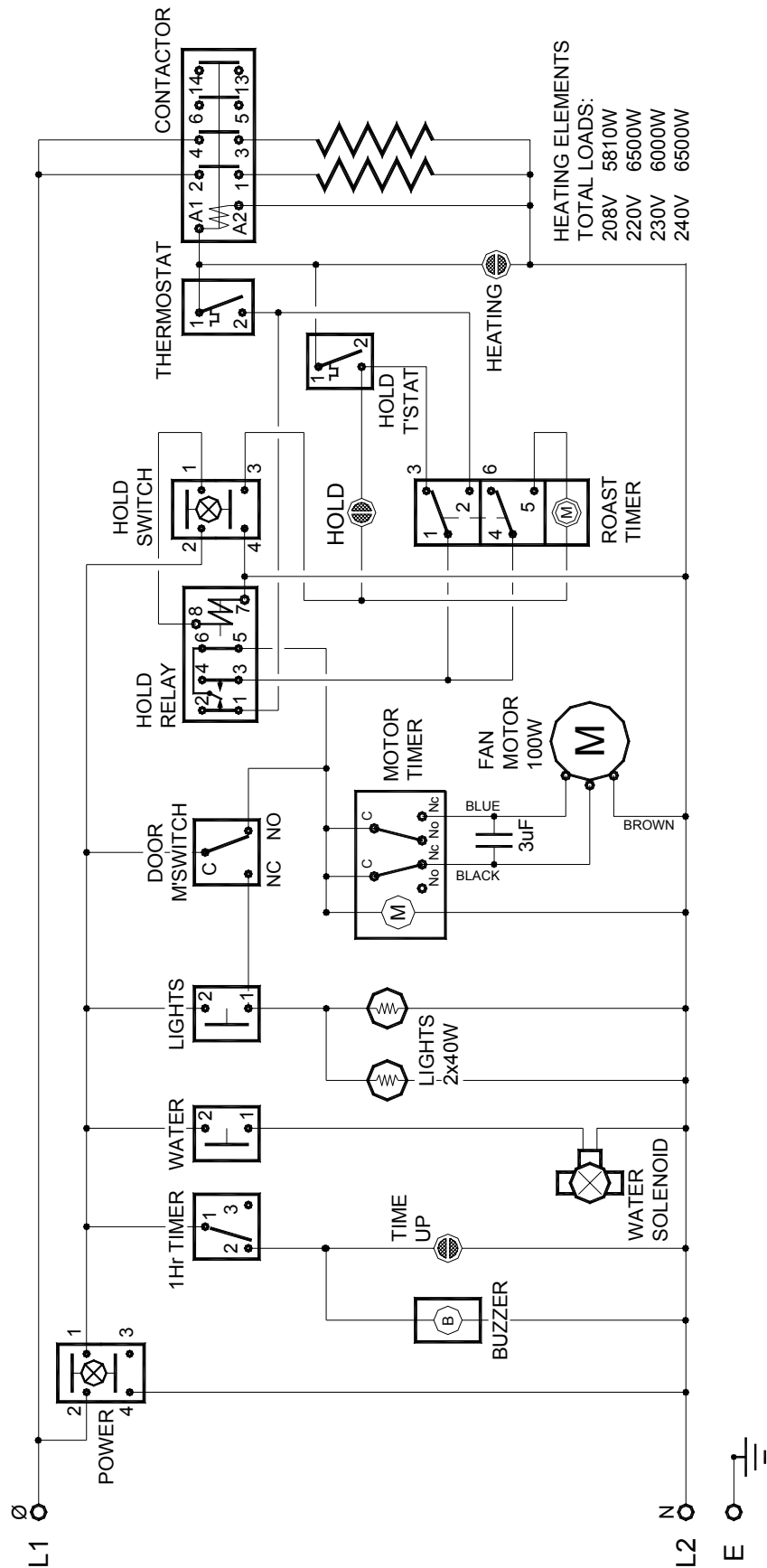

Figure 6.4.8

- 3) The timer can now be rotated a small amount to ensure that the buzzer sounds and indicator illuminates at the zero (time up) position.

# 7. ELECTRICAL CIRCUIT SCHEMATIC



# 8. ELECTRICAL WIRING DIAGRAM

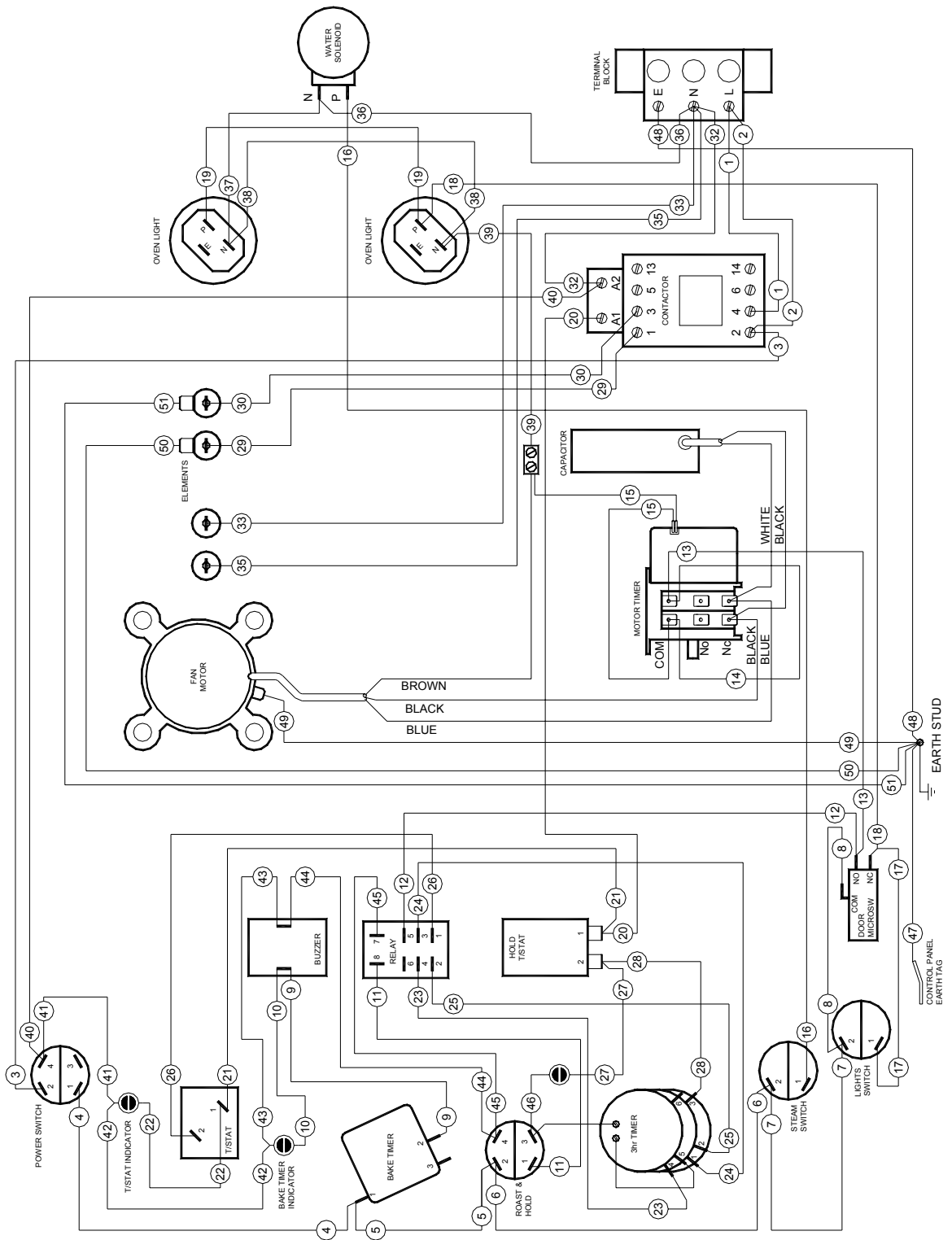

---

## 9. SPARE PARTS

### Controls

021473	Power Switch
024774	Thermostat
021472	Knob - Thermostat
020849	Neon Indicator
011760	Bake Timer
011794	Buzzer
021476	Switch- Roast 'n' Hold
011419	Roast 'n' Hold Timer
020823	Knob - Bake Timer / Roast 'n' Hold Timer
021474	Steam Switch
024773	Light Switch
015966	Contactactor - Elements
021534	Relay - Roast 'n' Hold
018223	Hold Thermostat
024802	Microswitch
003002	Oven Lamp Glass
003434	Silk Gasket
013521	Oven Lamp - 40W Miniature Edison Screw

### Motor & Elements

015360	Element Assembly 208-220V
015363	Element Assembly 230-240V
024431	Fan Motor
024432	Capacitor 3uF
024503	Motor Timer 208-220V
024567	Motor Timer 220-240V
024433	Fan

### Steam System

020851	Water Solenoid
021057	Spray Nozzle Assembly
021526	Water Inlet Elbow
021527	Washer

### Door

024784	Door Seal (Side)
024785	Door Seal (Top/Bottom)
020082	Top Hinge
020083	Bottom Hinge
024809	Roller Catch
017905	Door Bush
021468	Door Handle (E32M)
024599	Door Handle Bracket (E32M)
024844	Door Outer Glass (E32M)
002340	Door Inner Glass (E32M)
024713	Door Handle (E32MS)
023063	Door Glass (E32MS)

### Racks

015575	Oven Side Rack LH
015656	Fan Baffle
015168	Oven Rack

### Stacking Kit

021543	Double Stacking Kit
--------	---------------------

## 10. ACCESSORIES

**OVEN RACKS (PART NO 15168)**

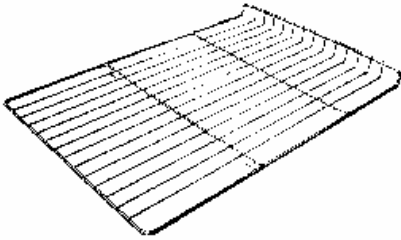

**100 MM (FOUR INCH) FOOT OPTION (PART NO 13048)**

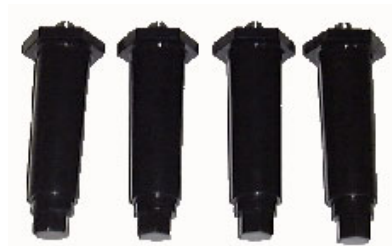

**25 MM (ONE INCH) FOOT OPTION (PART NO 13908)**



**COOKIE KIT—SIX TRAY OPTION (PART NOS 17156 & 17157)**



**DOUBLE STACKING KIT (PART NO 025012)**



**A25 STAINLESS STEEL STAND**



# 11. PARTS DIAGRAMS

## 11.1 MAIN ASSEMBLY

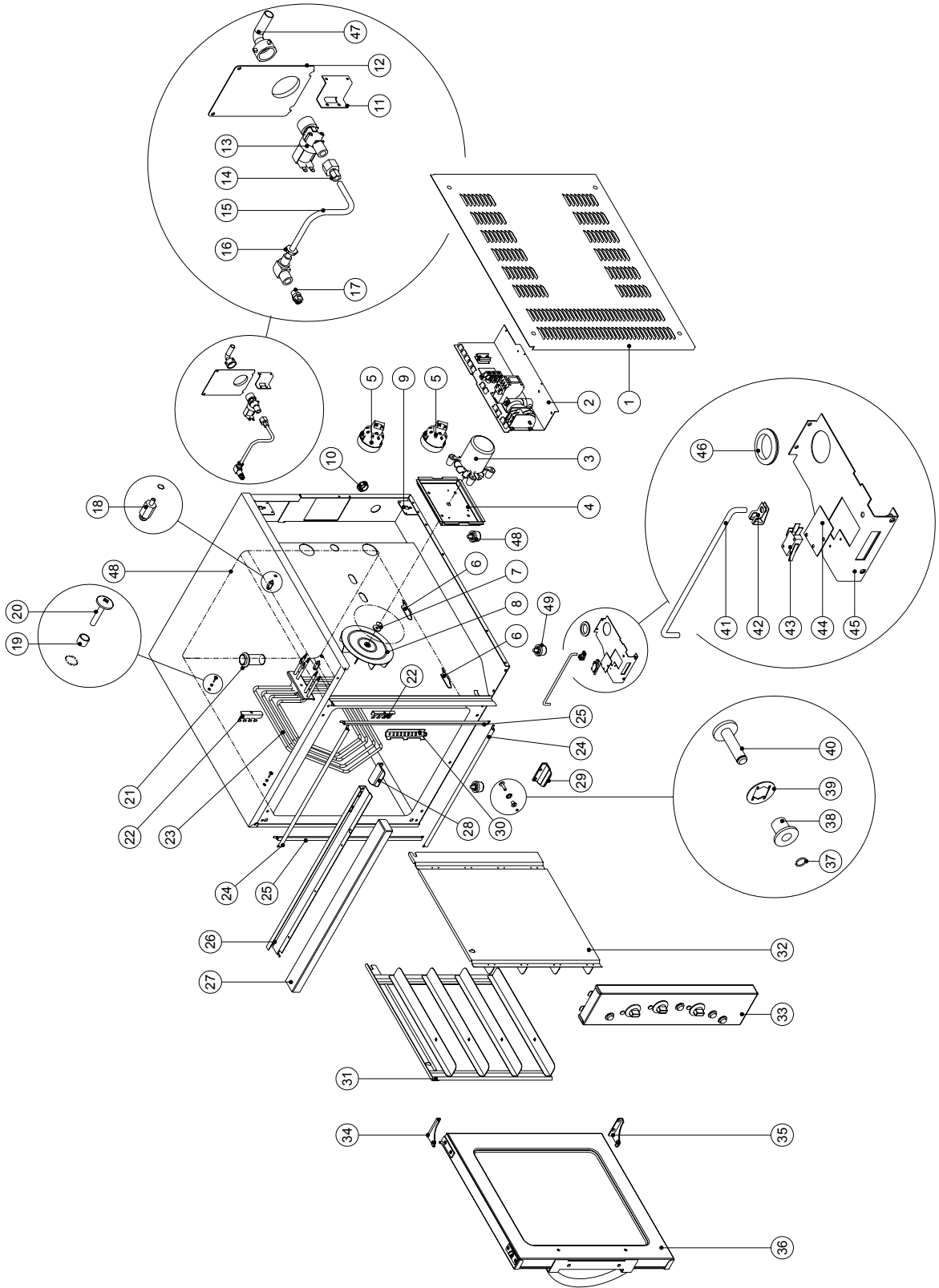

Pos	Part No.	Description
1	024683	SIDE COVER RH
2	-----	GEAR TRAY ( <b>REFER SECTION 11.3</b> )
3	024431	FAN MOTOR
4	024604	MOTOR MOUNTING PLATE
5	013520	OVEN LIGHT ASSEMBLY
	003434	SILK GASKET
	013521	LAMP - 40W
	003002	LIGHT GLASS
6	024717	BAFFLE LOCATING PLATE
7	024478	FAN SHAFT SEAL
8	024433	FAN
9	024689	SIDE PANEL MOUNTING BRACKET
10	019213	SNAP BUSH 32mm
11	024702	WATER SOLENOID MOUNTING BRACKET
12	021619	REAR SERVICE PANEL
13	020851	WATER SOLENOID
14	020869	CONNECTOR $\frac{3}{8}$ "F x $\frac{1}{4}$ "COMP
15	021058	WATER TUBE / ELBOW ASSEMBLY
16	013215	BACKNUT
17	021057	SPRAY NOZZLE
18	014031	OVEN BAFFLE STUD
19	003397	SPACER
20	041405	SCREW $\frac{1}{2}$ " x $\frac{3}{16}$ "
21	024760	VENT TUBE
22	015581	ELEMENT BRACKET
23	015360	ELEMENT ASSEMBLY ( <b>208-220V</b> )
	015363	ELEMENT ASSEMBLY ( <b>220-240V</b> )
24	024785	TOP/BOTTOM DOOR SEAL
25	024784	LEFT/RIGHT DOOR SEAL
26	024672	LINTEL SUPPORT
27	004945	LINTEL ENAMELLED ( <b>E32M</b> )
	024847	LINTEL S/S ( <b>E32MS</b> )
28	024803	ROLLER STRIKE TOP
29	024804	ROLLER STRIKE BOTTOM
30	013974	PHIAL GUARD
31	015575	SIDE RACK LH
32	015656	FAN BAFFLE
33	-----	CONTROL PANEL ( <b>REFER SECTION 11.2</b> )
34	020082	TOP HINGE ( <b>ASSEMBLED WITH BUSH</b> )
	017905	BUSH
35	020083	BOTTOM HINGE ( <b>ASSEMBLED WITH BUSH</b> )
	017905	BUSH
36	-----	DOOR ASSEMBLY ( <b>REFER SECTION 11.4</b> )
37	021638	PIN CIRCLIP
38	013610	BUSH
39	044210	SPIRE CLIP
40	021637	MICROSWITCH BUTTON
41	024791	MICROSWITCH ROD
42	017929	DAMPER ROD CLIP
43	024802	MICROSWITCH
44	013977	INSULATOR
45	024584	MICROSWITCH BRACKET
46	010761	GROMMET $\phi$ 1 $\frac{1}{2}$ " RUBBER
47	021526	WATER INLET ELBOW
	021527	WATER INLET WASHER
48	004924	OVEN LINER
49	013908	FOOT ASSEMBLY $\frac{3}{8}$ "
	013048	4" HI TEMP PLASTIC LEG ( <b>OPTIONAL</b> ) – NOT ILLUSTRATED



## 11.2 CONTROL PANEL ASSEMBLY

### 11.2.1 E32M Control Panel

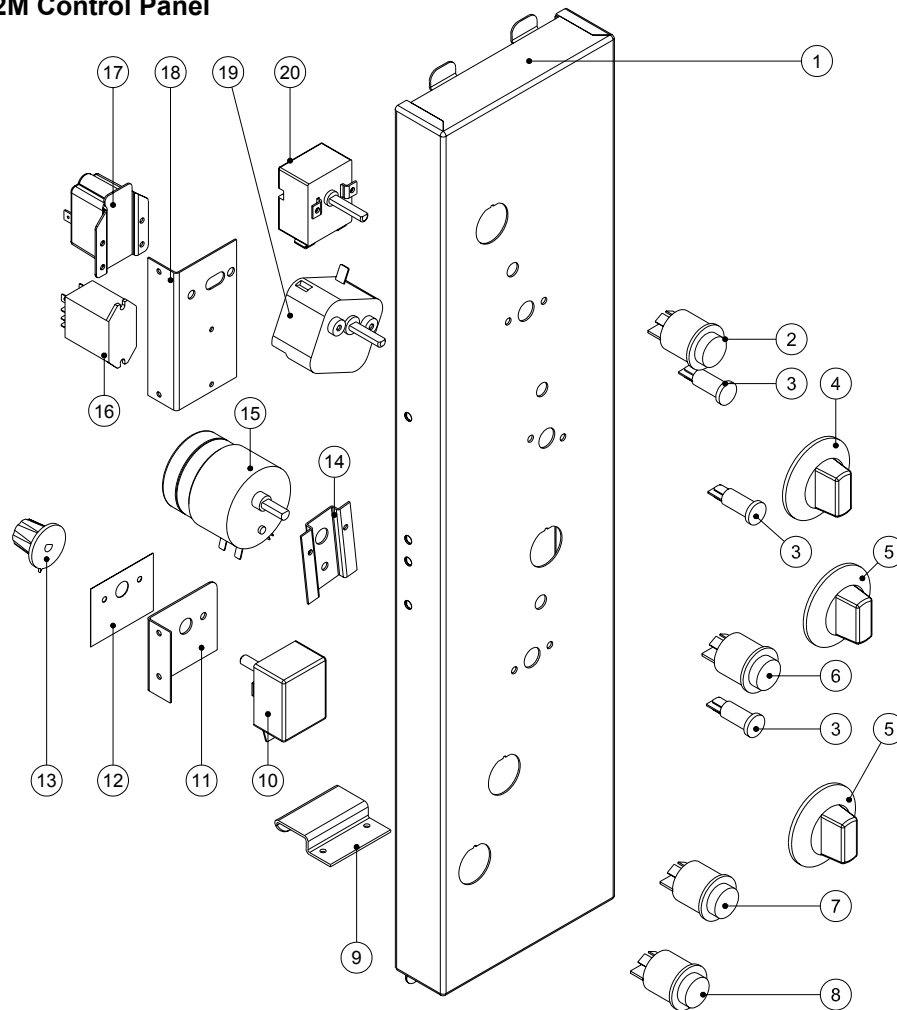

Pos	Part No.	Description
1	004953	CONTROL PANEL BAKBAR °C
	004954	CONTROL PANEL BLUE SEAL °C
2	021473	POWER SWITCH
3	020849	INDICATOR LIGHT
4	021472	THERMOSTAT KNOB
5	020823	TIMER KNOB
6	021476	ROAST N HOLD SWITCH
7	021474	STEAM SWITCH
8	024773	LIGHT SWITCH
9	024694	CONTROL PANEL HOOK
10	018223	HOLD THERMOSTAT
11	021538	HOLD STAT BRACKET
12	018209	HOLD STAT LABEL
13	018224	HOLD STAT KNOB
14	021442	TIMER MOUNTING PANEL
15	011419	3 HOUR TIMER (50Hz)
	011983	3 HOUR TIMER (60Hz)
16	021534	RELAY
17	011794	BUZZER
18	024703	BUZZER/RELAY BRACKET
19	011760	60 MINUTE TIMER
20	024774	THERMOSTAT

## 11.2.2 E32MS Control Panel

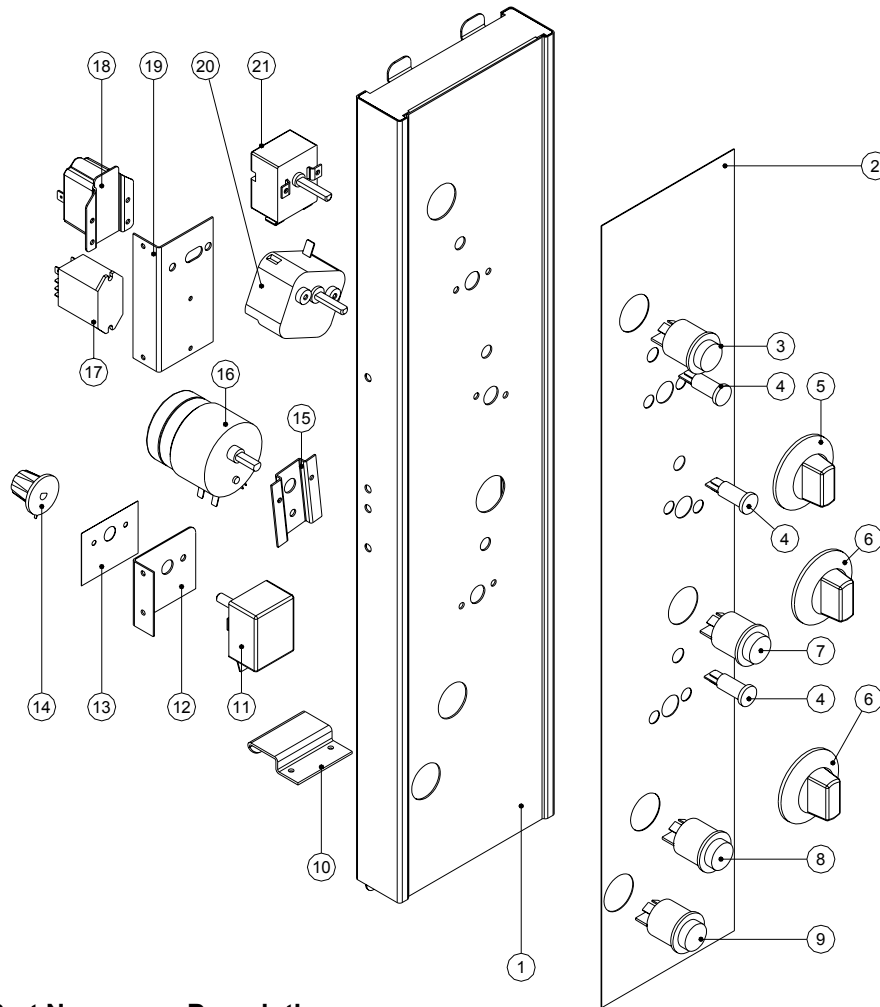

Pos	Part No.	Description
1	024805	CONTROL PANEL ST/ST
2	024775	OVERLAY BAKBAR °C
	024776	OVERLAY BLUE SEAL °C
	024777	OVERLAY MOFFAT °F
3	021473	POWER SWITCH
4	020849	INDICATOR LIGHT
5	021472	THERMOSTAT KNOB
6	020823	TIMER KNOB
7	021476	ROAST N HOLD SWITCH
8	021474	STEAM SWITCH
9	024773	LIGHT SWITCH
10	024694	CONTROL PANEL HOOK
11	018223	HOLD THERMOSTAT
12	021538	HOLD STAT BRACKET
13	018209	HOLD STAT LABEL
14	018224	HOLD STAT KNOB
15	021442	TIMER MOUNTING PANEL
16	011419	3 HOUR TIMER (50Hz)
	011983	3 HOUR TIMER (60Hz)
17	021534	RELAY
18	011794	BUZZER
19	024703	BUZZER/RELAY BRACKET
20	011760	60 MINUTE TIMER
21	024774	THERMOSTAT 50-320°C

---

### 11.3 GEAR PLATE ASSEMBLY

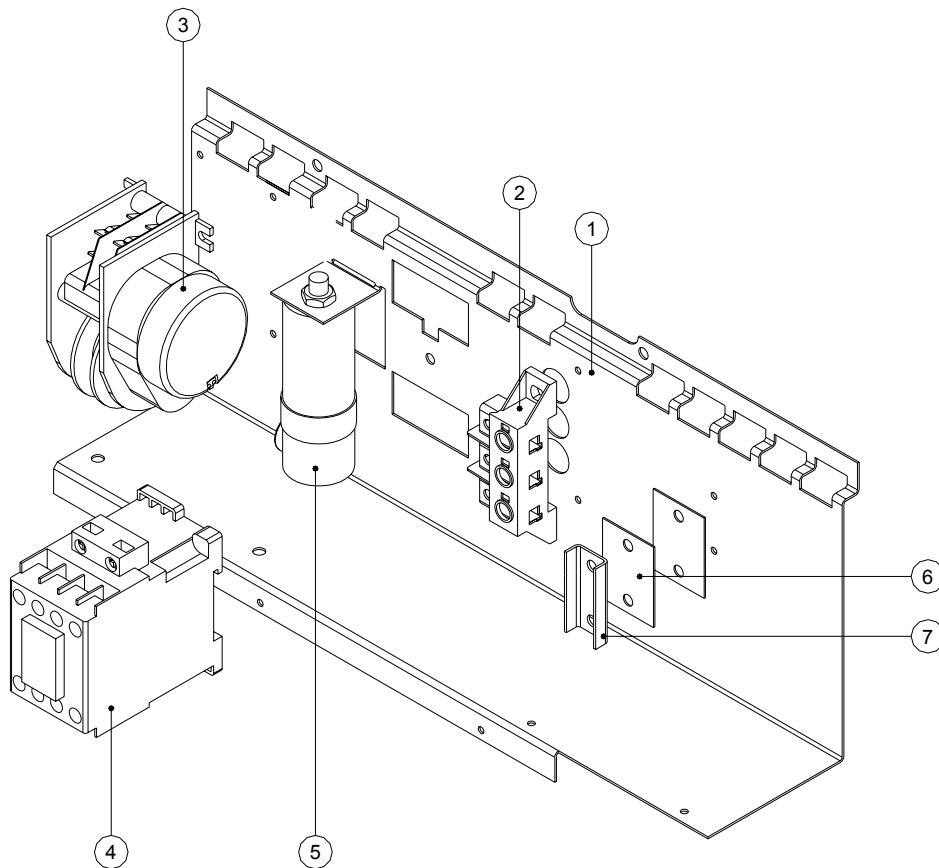

Pos	Part No.	Description
1	024772	GEAR TRAY
2	014185	MAIN TERMINAL BLOCK
3	024567	MOTOR TIMER 240V
	024503	MOTOR TIMER 220V
4	015966	CONTACTOR
5	024432	CAPACITOR 3µF
6	002441	INSULATOR
7	002138	CABLE CLAMP

## 11.4 DOOR ASSEMBLY

### 11.4.1 E32M Glass Door Assembly

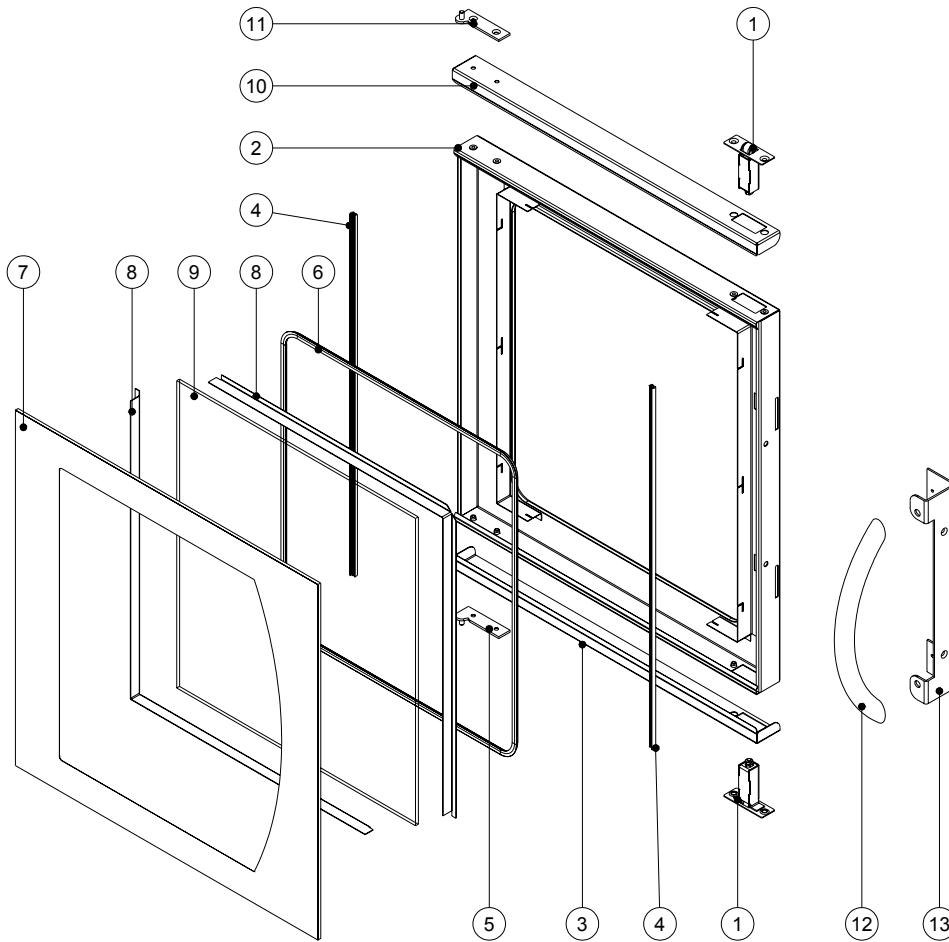

Pos	Part No.	Description
1	024809	ROLLER CATCH ASSEMBLY
2	004928	DOOR INNER ENAMELLED
3	024602	DOOR TRIM BOTTOM
4	090225	GLASS SEAL EXTRUSION (1.14m)
5	020083	BOTTOM HINGE ASSEMBLY
6	090200	GLASS SEAL EXTRUSION (1.74m)
7	024844	DOOR OUTER GLASS
8	004452	GLASS CLAMP ANGLE PAINTED
9	002340	DOOR INNER GLASS
10	024601	DOOR TRIM TOP
11	020082	TOP HINGE ASSEMBLY
12	021468	DOOR HANDLE
13	024599	DOOR HANDLE BRACKET
	SA1586	DOOR COMPLETE (EXCLUDES HANDLE & BRACKET)

## 11.4.2 E32MS Stainless Steel Door Assembly

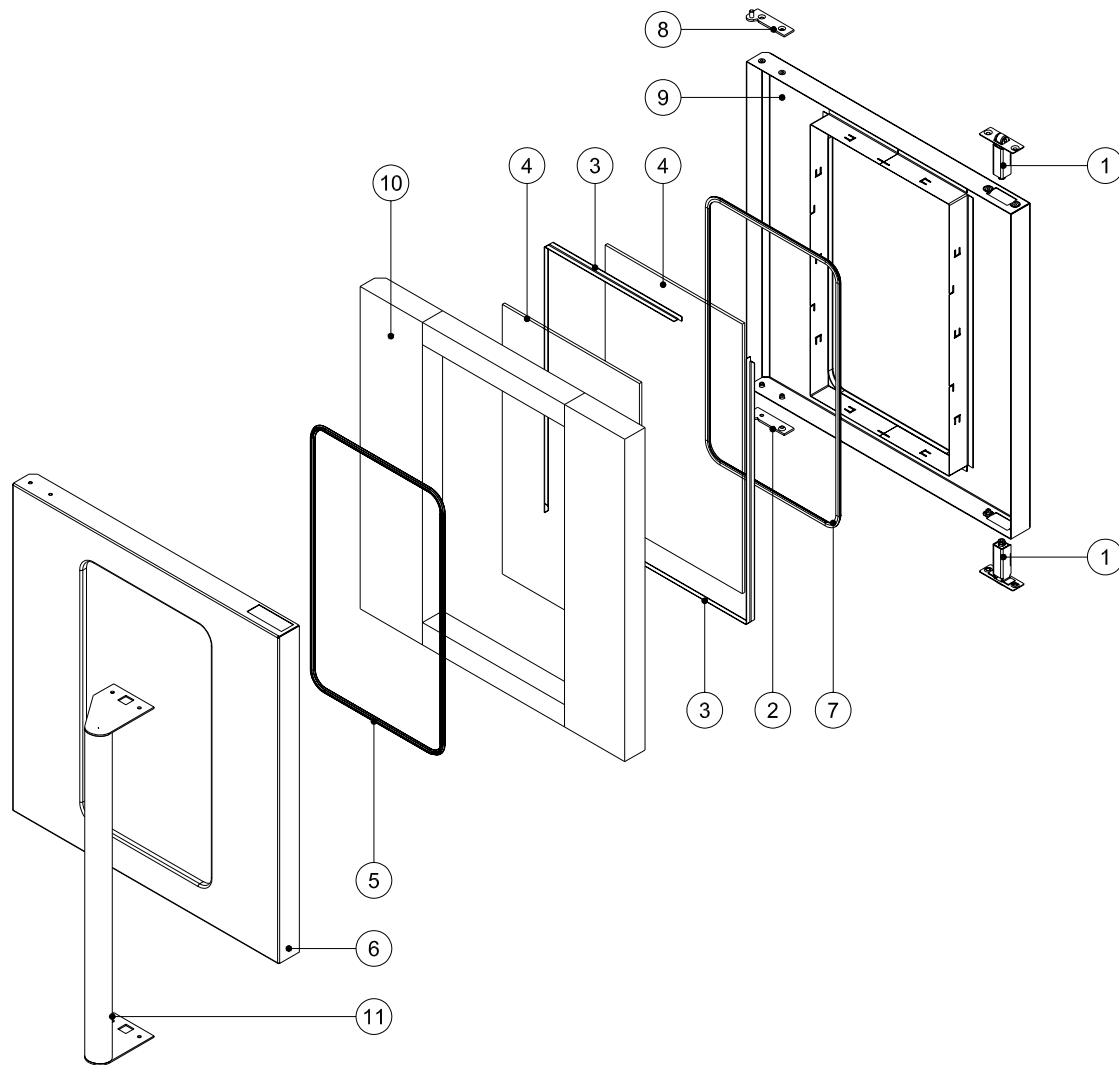

Pos	Part No.	Description
1	024809	ROLLER CATCH ASSEMBLY
2	020083	BOTTOM HINGE ASSEMBLY
3	024605	GLASS CLAMP ANGLE
4	023063	DOOR WINDOW GLASS
5	090201	GLASS SEAL EXTRUSION (1.44m)
6	024845	DOOR OUTER PANEL
7	090200	GLASS SEAL EXTRUSION (1.44m)
8	020082	TOP HINGE ASSEMBLY
9	004957	DOOR INNER (ENAMELLED)
10	-----	INSULATION
11	024713	DOOR HANDLE
	SA1587	ST/ST DOOR COMPLETE

---

## 11. SERVICE CONTACTS

### AUSTRALIA

#### VICTORIA - MOFFAT PTY

HEAD OFFICE AND MAIN WAREHOUSE  
740 Springvale Road  
Mulgrave VIC 3170  
Spare Parts Department

Tel (03) 9518 3888  
Fax (03) 9518 3838  
Free Call 1800 337 963  
Fax (03) 9518 3895

#### NEW SOUTH WALES - MOFFAT PTY

Unit 8/142 James Ruse Drive  
Rosehill NSW 2142  
Spare Parts

Free Call 1800 337 963  
Fax (03) 9518 3895

#### QUEENSLAND - MOFFAT PTY

30 Prosperity Place  
Geebung QLD 4034  
Spare Parts

Free Call 1800 337 963  
Fax (03) 9518 3895

#### SOUTH AUSTRALIA - MOFFAT PTY

28 Greenhill Rd  
Wayville SA 5034  
Spare Parts

Tel (08) 8274 2116  
Free Call 1800 337 963

#### WESTERN AUSTRALIA - MOFFAT PTY

PO Box 689  
Joondalup Business Centre WA 6027  
Spare Parts

Tel (08) 9305 8855  
Free Call 1800 337 963

**NATIONAL COVERAGE FOR 24 HOUR SERVICE OR MAINTENANCE DIAL  
FREE CALL 1800 622 216 (AUSTRALIA ONLY)**

### CANADA

Lessard Agencies Limited  
PO Box 97  
Stn "D"  
Toronto, ONT M6P 3J5

Tel (416) 766 2764  
Fax (416) 760 0394  
Free Call 1 888 537 7273

### NEW ZEALAND

#### CHRISTCHURCH - MOFFAT LTD

16 Osborne St  
PO Box 10-001  
Christchurch  
Spare Parts

Free Call 0800 Moffat  
(0800 663 328)

Tel (03) 389 1007  
Fax (03) 389 1276

#### AUCKLAND - MOFFAT LTD

4 Waipuna Road  
Mt Wellington  
Auckland  
Spare Parts

Tel (09) 574 3150  
Fax (09) 574 3159

Free Call 0800 Moffat  
(0800 663 328)

---

**UNITED KINGDOM**

BLUESEAL LTD  
Units 6-7 Mount St  
Business Park  
Birmingham B7 5QU  
England

Tel 0121-327 5575  
Fax 0121-327 9711

**UNITED STATES OF AMERICA**

MOFFAT INC.  
3765 Champion Blvd  
Winston-Salem  
NC27115

Tel 1-800-551 8795  
Fax 336 661 9546

**NATIONAL COVERAGE FOR SERVICE OR MAINTENANCE DIAL  
FREE CALL 1800 551 8795 (USA ONLY)**

## APPENDIX A. STACKING BASE STAND

Kit contents (refer diagram below):

Position	Description	Quantity
1	Stand side frame	2
2	Stand rail WA	2
3	M6 x 12 Hex head screw	12
4	$\frac{1}{4}$ " Spring washer	12
5	$\frac{3}{8}$ " x 1" Hex head screw	4
6	$\frac{3}{8}$ " Spring washer	4

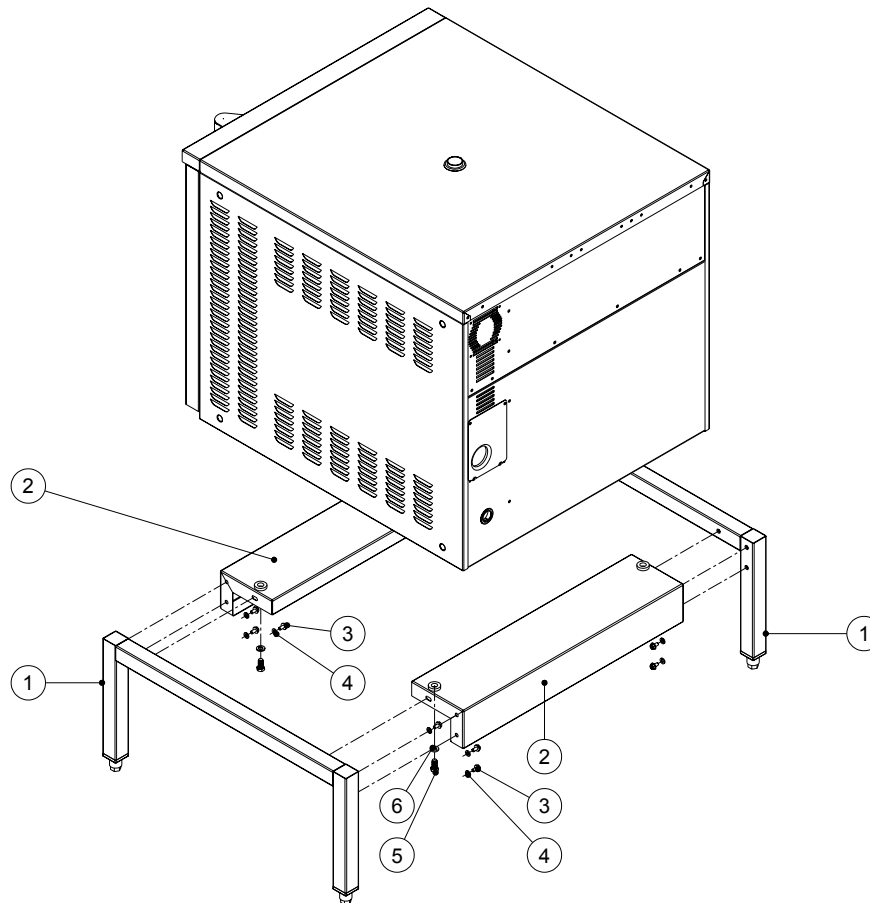

Figure 1 - Non castor option illustrated

**THE ELECTRICAL SUPPLY MUST BE DISCONNECTED PRIOR TO COMMENCEMENT**

**Procedure:**

- Screw the stand rails (2) to the stand side frames (1), with three M6 hex head screws (3) and  $\frac{1}{4}$ " spring washers (4) at each end. (Refer to the illustration above).
- Tip the oven onto its back and remove the 1" or 4" feet screwed into the base.
- Screw the assembled stand onto the bottom of the oven using the four  $\frac{3}{8}$ " x 1" hex screws (5) and  $\frac{3}{8}$ " spring washers (6).

**NOTE:** For castor option, ensure that the total brake castors (red lock) are at the front of the unit, and the direction lock only castors (green lock) are at the rear of the unit.

**For units being installed on castors a suitable restraint chain must be fitted.**



## APPENDIX B. DOUBLE STACKING KIT

Kit contents (refer diagram overleaf):

Position	Description	Quantity
1	Shroud front	1
2	Shroud sides	2
3	Shroud rear	1
4	Chimney	1
5	Chimney support	1
6	Flue duct	1
7	$\frac{1}{2}$ " x 8A Pozi screws	20
8	$\frac{3}{4}$ " x $\frac{3}{16}$ " Phillips head screws	8
9	$\frac{5}{8}$ " x $\frac{3}{8}$ " Hex head screws	4
9	$\frac{3}{8}$ " Spring washers	4

**THE ELECTRICAL SUPPLIES TO BOTH OVENS MUST BE DISCONNECTED  
PRIOR TO COMMENCEMENT**

### A. Bottom Unit - E32/M/MS

- Assemble and fit the stand to the bottom unit (refer Appendix A).
- **Units manufactured prior to S/N 239683 (July 2002) only:**  
Unscrew the vent hood plate from the bottom oven. Remove and discard the hood plate and spacer tubes. Replace the vent hood screws and completely screw in to secure the wrapper to the spacer tube.
- Position the shroud rear (**3**) (refer figure 2) on top of the bottom unit so that it is positioned correctly over the oven back. Position the flue duct (**6**) on the bottom unit so that it is positioned centrally in shroud rear flue cut-out and is flush with the oven back. Check that the oven vent is covered and mark the six hole positions (three down each side of the flue duct) on the oven wrapper.
- Drill six  $\varnothing 3.5\text{mm}$  ( $\frac{1}{8}$ " ) holes in the oven wrapper where marked.
- Apply a small amount of silicone sealant to the flue duct flanges and screw to the wrapper with six  $\frac{1}{2}$ " x 8A pozi screws (**7**) along the top, and two at the rear.

### B. Top Unit - E32/M/MS

- Tip the oven onto its back and remove the feet screwed into the base.
- Assemble the four sides of the shroud (shroud front (**1**), shroud sides x2 (**2**), and shroud rear (**3**)) with the  $\frac{3}{16}$ " screws (**8**) as illustrated. Do not fully tighten the screws until the ovens are stacked.
- Screw the shroud assembly to the base of the top oven using the  $\frac{3}{8}$ " hex head screws and washers (**9**) so that all faces of the shroud are flush with the sides of the oven base. Be sure to have the large flange of the shroud rear at the back of the oven.

### C. Stacking the Ovens

- Remove three screws along the top rear of the bottom oven.
- With two or three persons, lift the top oven onto the bottom oven and position so that the down folds on the shroud sides and rear all butt hard up around the sides and rear of the oven wrapper.

- Secure the top unit into position by replacing the three screws along the rear of the oven.
- Drill three  $\varnothing 3.5\text{mm}$  ( $\frac{1}{8}$ " ) holes along each side of the bottom oven and secure with six  $\frac{1}{2}$ " x 8A pozi screws (7).
- Position the chimney (4) on the rear of the units. Secure to the flue duct (6) and bottom unit with four  $\frac{1}{2}$ " x 8A pozi screws (7). (The holes in the bottom unit may need to be drilled,  $\varnothing 3.5\text{mm}$  ( $\frac{1}{8}$ " )).
- Secure the top of the chimney to the top unit with the chimney support (5) and two  $\frac{1}{2}$ " x 8A pozi screws (7). (These holes may need to be drilled,  $\varnothing 3.5\text{mm}$  ( $\frac{1}{8}$ " )).
- Ensure that all screws on the stacking kit are tightened.

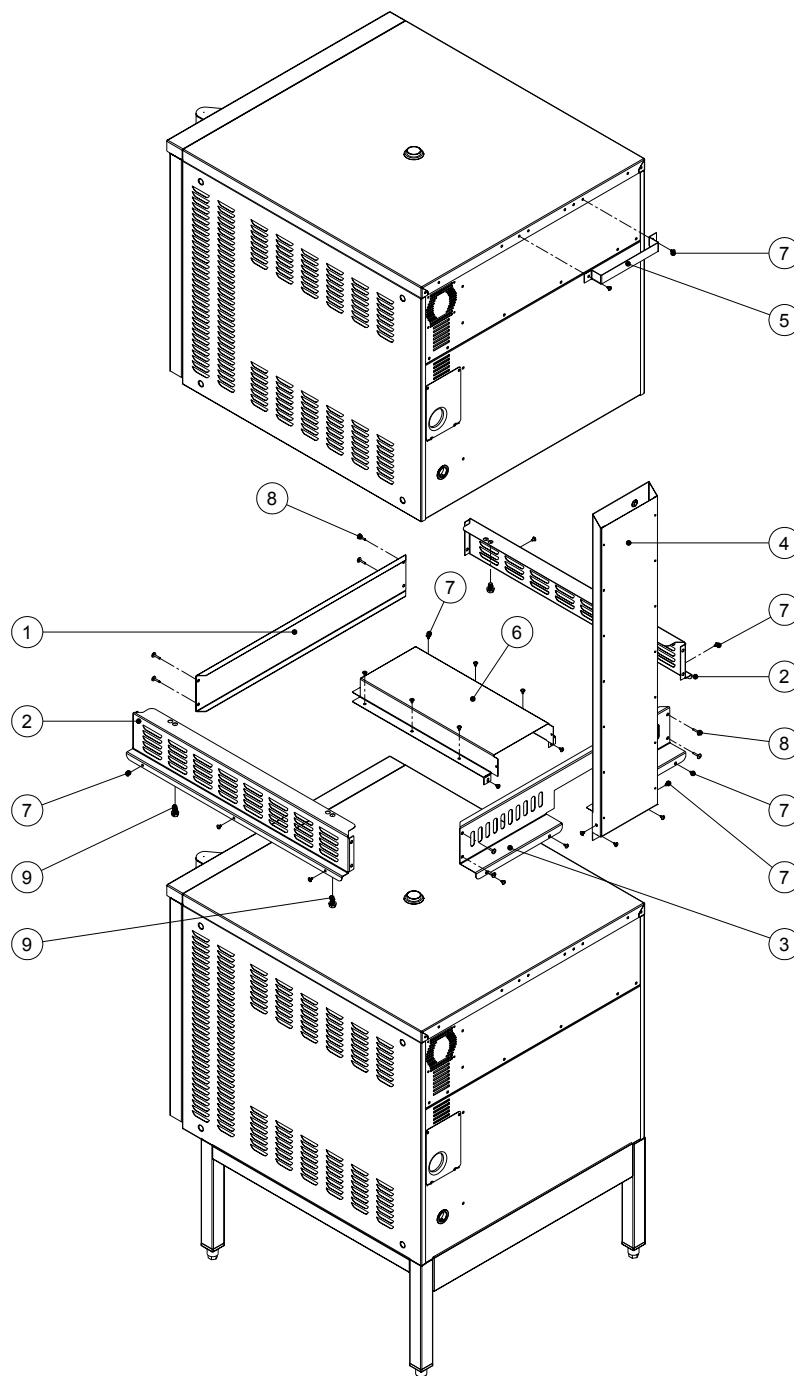

Figure 2