

EFFECTIVE: MAY, 2008

American Dish Service

ADS CONVEYOR DISHWASHER
MODELS: ADC-44 L-R/R-L

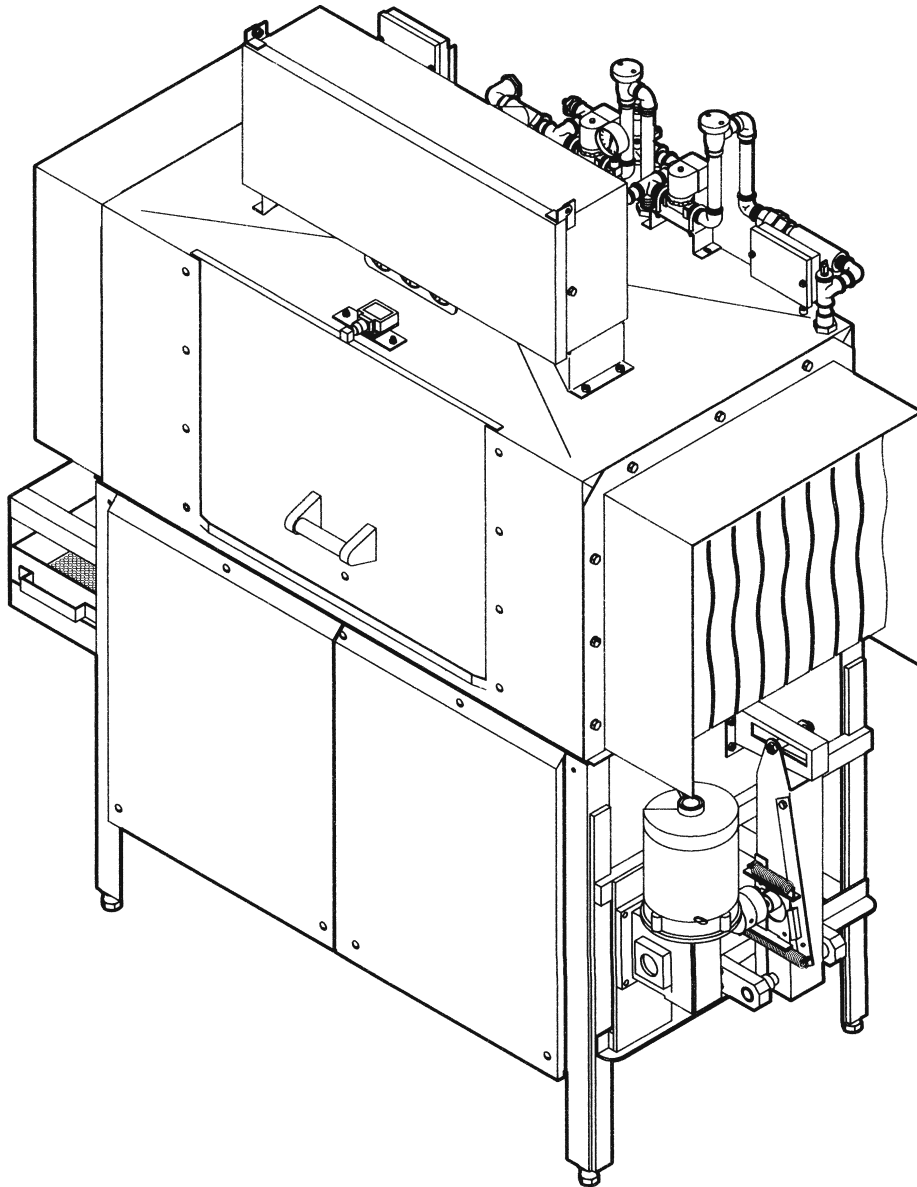

PARTS MANUAL

900 Blake Street
Edwardsville, Kansas 66111
(913)422-3700

211-0044L-R / 212-0044R-L

ADC-44 Conveyor
Dishwasher

American Dish Service

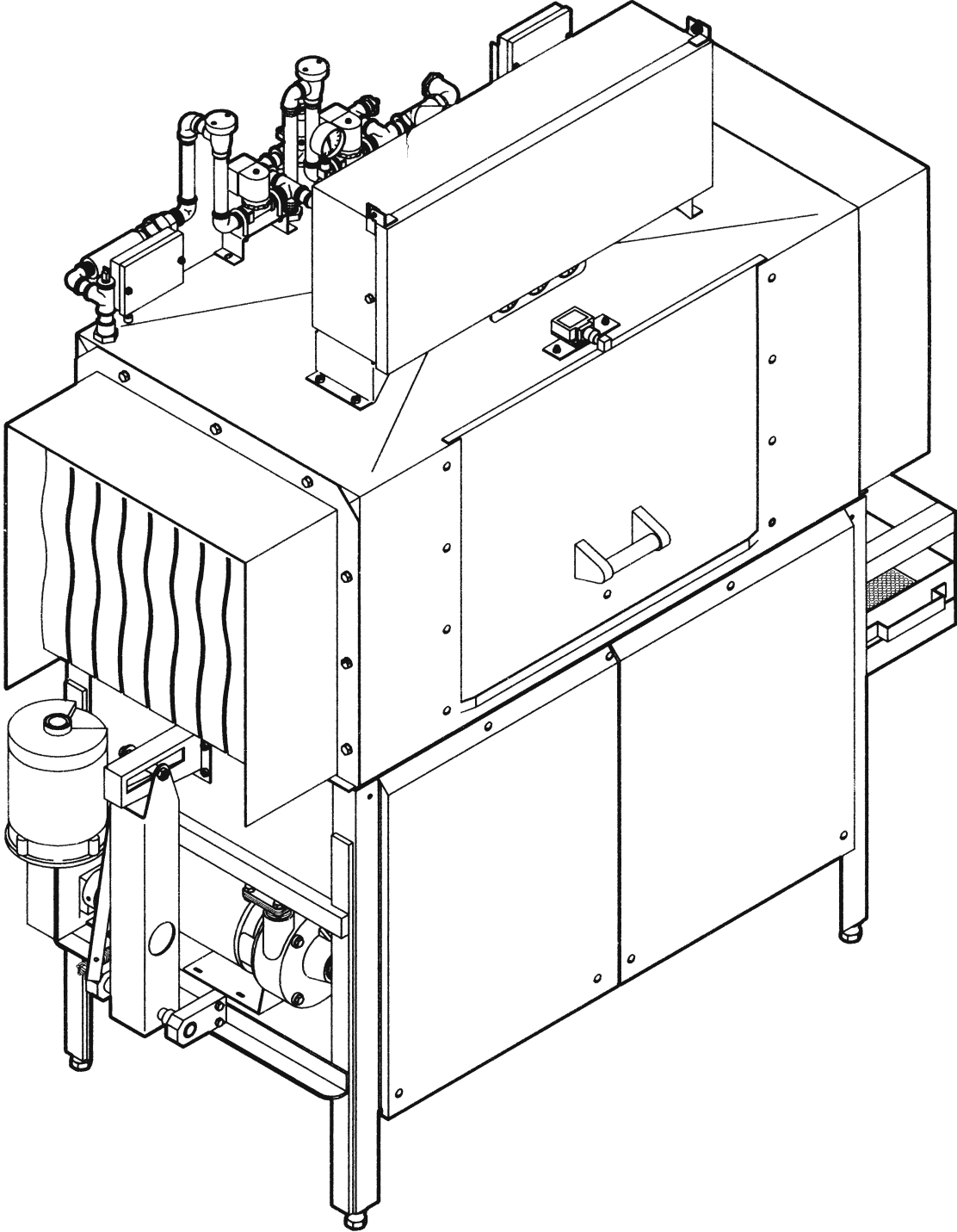

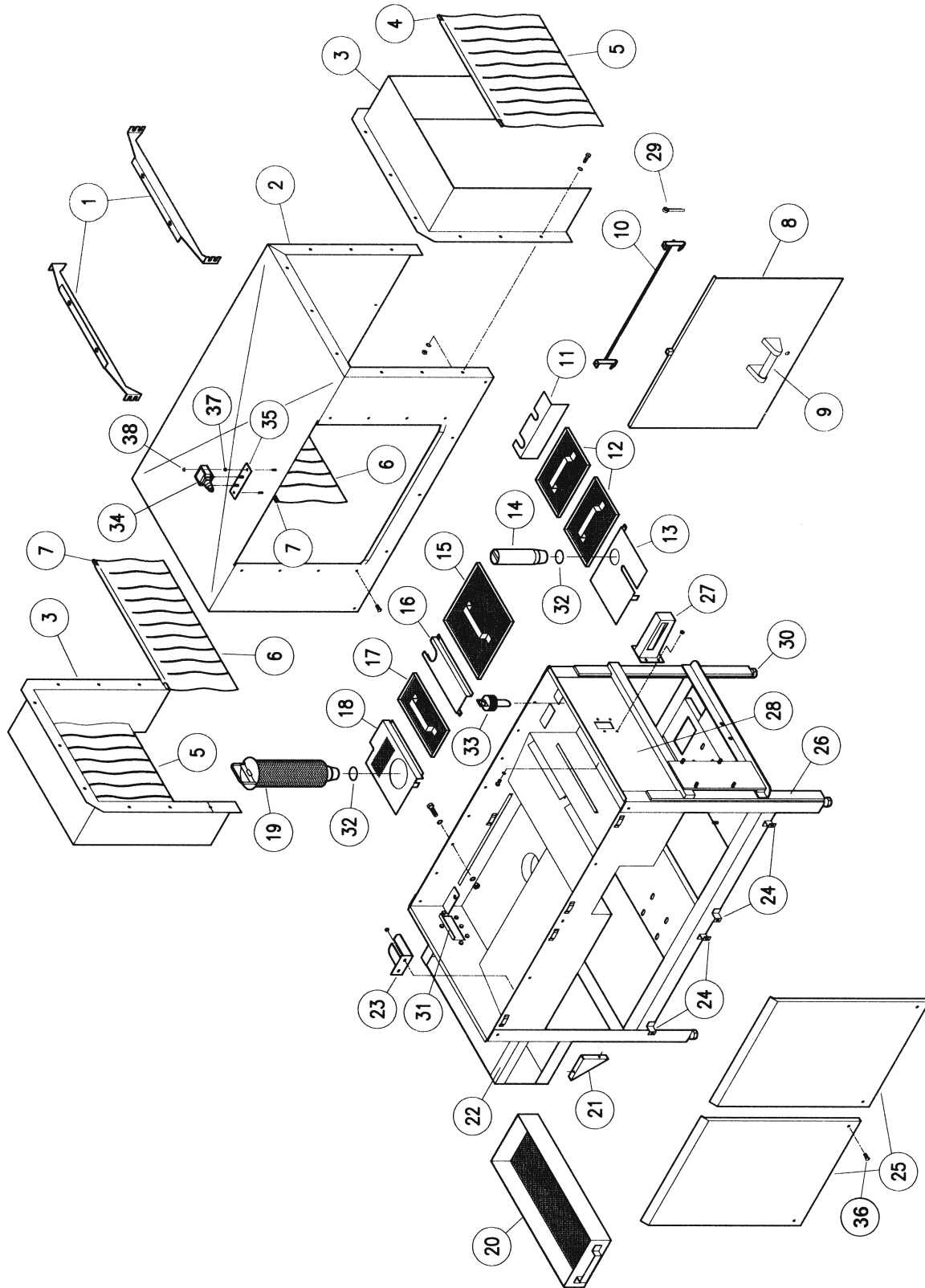

261-0100
Cabinet Assembly
ADC-44 L-R

American Dish Service

Ref. No.	Part No.	No. Req.	Description
1	287-6124	2	Support, Hood Top
2	285-6144	1	Hood Weldment, L-R
3	285-6115	2	Hood End Shield Weldment
N/S	285-6116	Opt. 2	Vent Weldment, Hood End Shield
4	284-6122	2	Rod, Curtain 5/16" x 20.5" Lg
5	299-1001	2	Curtain 21" Wide x 17" Tall
6	299-1002	2	Curtain 23" Wide x 11" Tall
7	284-6121	2	Rod, Curtain 5/16" x 23.5" Lg
8	285-6124	1	Door Weldment, Front Access
N/S	287-6123	2	Door Guide, SS
9	285-6139	1	Handle Weldment, Front Access Door
10	285-6125	1	Latch Weldment, Door
11	285-6152	1	Cover Weldment, Rinse Float, L-R
12	285-6123	2	Screen Weldment, Rinse Tank
13	286-6200	1	Plate, Rinse Stand Tube, L-R
14	285-6172	1	Plug Weldment, Rinse Stand Tube
N/S	281-6210		Drain Stand Tube, with O-Ring, Rinse Tank
15	285-6145	1	Screen Weldment, Wash Tank Large L-R
16	286-6179	1	Cover, Wash Manifold
17	285-6122	1	Screen Weldment, Wash Small
18	286-6197	1	Plate, Wash Pump Filter L-R
19	285-6174	1	Filter Weldment, Wash Pump w/Taper
N/S	281-6211		Filter, Wash Pump with O-Ring
20	289-9109	1	Tray, Scrap Trap, Complete
21	289-9114	1	Support, Scrap Trap
22	289-9111	1	Scrap Trap
23	286-6182	1	Guard, Wash Magnet
24	285-6151	4	Mount Weldment, Lower, Front Panel
25	285-6120	2	Panel Weldment, Front
26	285-6150	1	Frame Weldment, L-R
27	285-6119	1	Drip Chute Weldment
N/S	289-6601	1	Gasket, Drip Chute
28	285-6182	1	Pan Weldment, L-R
29	098-8008	2	Cotter Pin, 3/32 x 1" SS

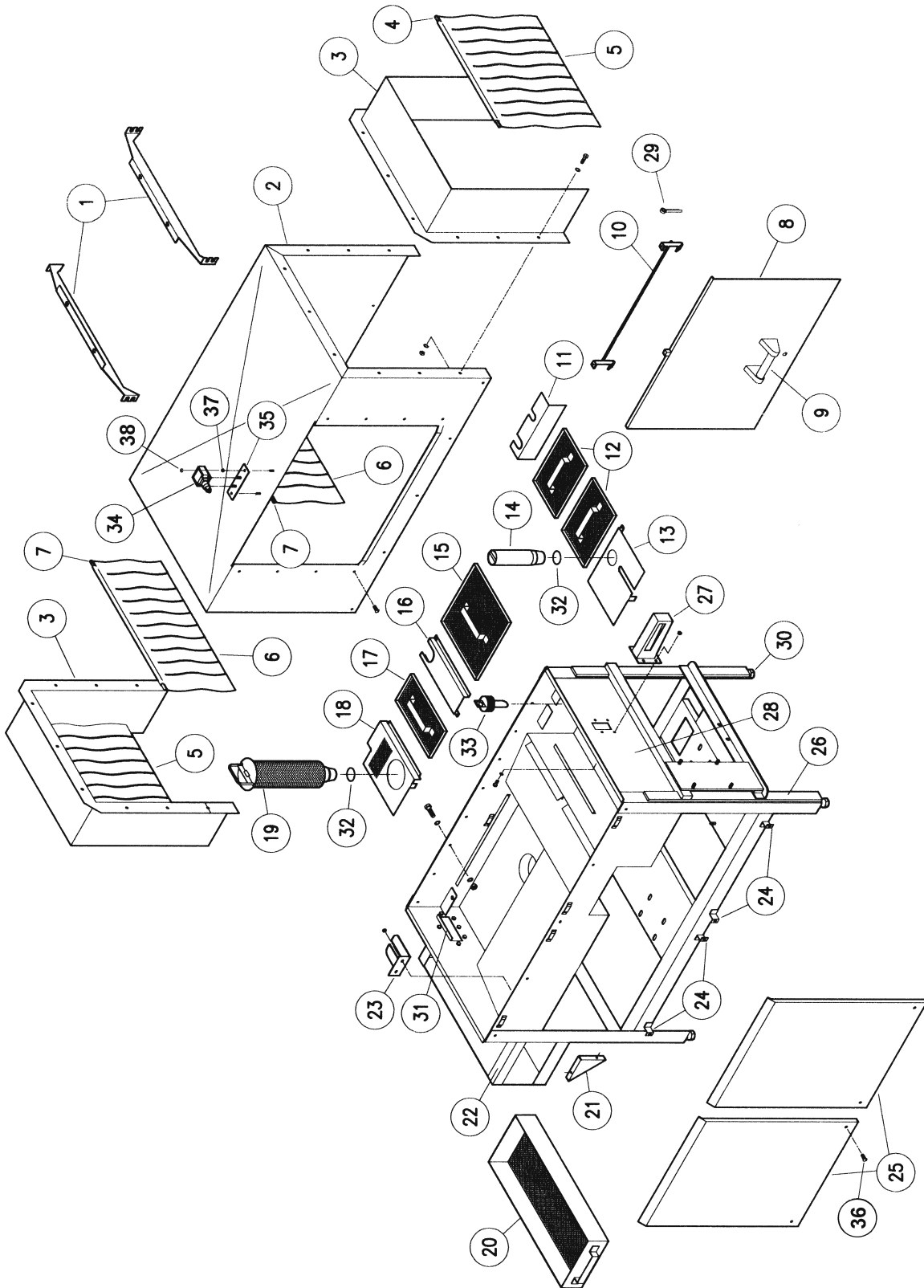

261-0100
 Cabinet Assembly
 ADC-44 L-R

American Dish Service

Ref. No.	Part No.	No. Req.	Description
30	099-1024	4	Bullet Feet
31	285-6132	1	Spacer Weldment, Scrap Trap
N/S	289-6602	2	Gasket, Scrap Trap Spacer
32	289-6611	2	Gasket, 'O' Ring Wash/Rinse Taper
33	285-6162	1	Filter Screen Weldment, Rinse Pump
34	099-4502	1	Switch, Door Cut-Off
35	285-6103	1	Bracket, Door Cut-Off
N/S	285-6146	1	Cover, Transfer Chute Weldment
36	098-1414	4	Bolt, 1/4-20 x 1/2", TH, SS
N/S	286-6247	OBS	Baffle, Hood End Shield Vent, OBSOLETE
37	098-2507	2	Locknut, 1/4-20, SS
38	098-2301	2	Locknut, 10-32, SS

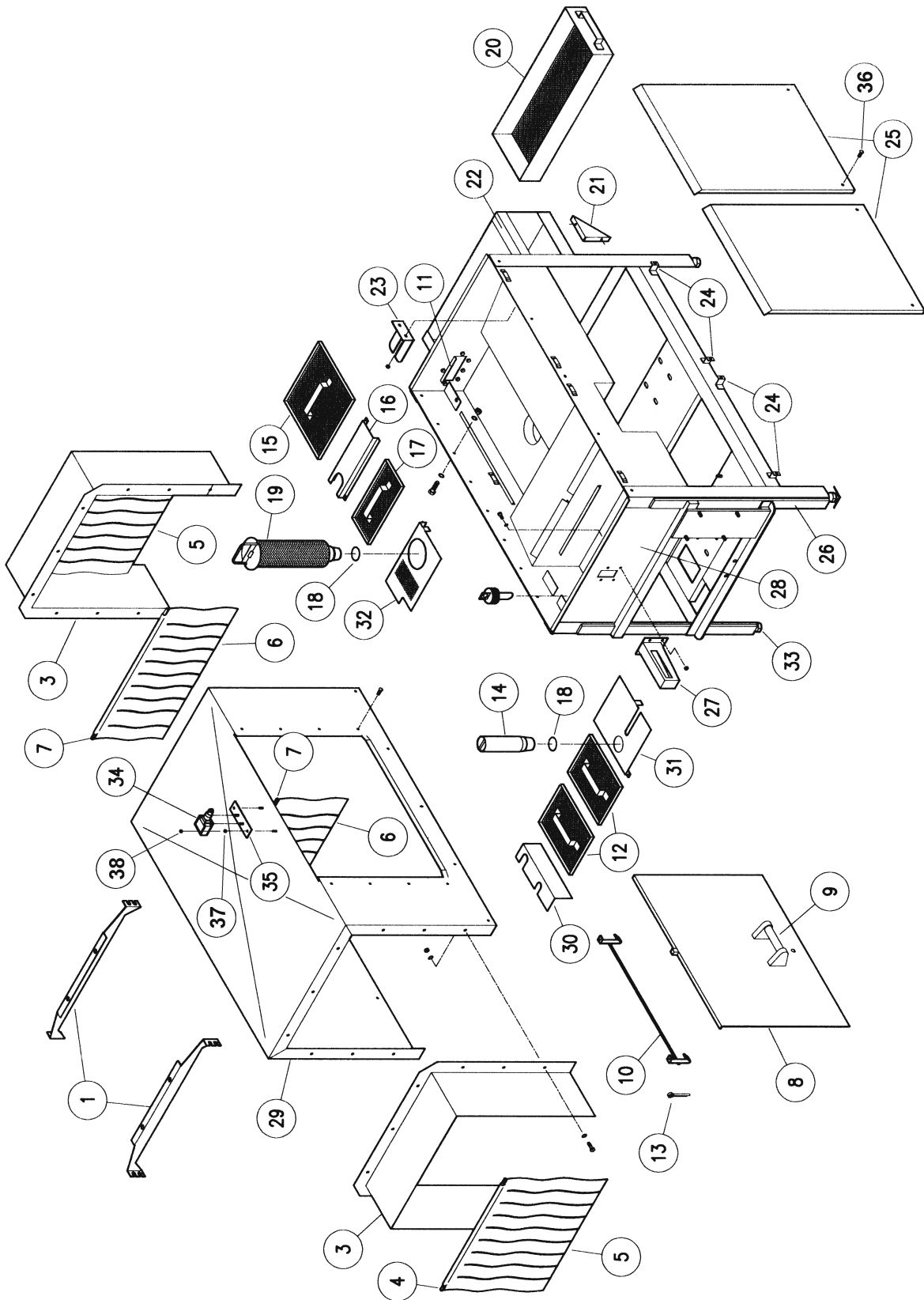

261-0200
Cabinet Assembly
ADC-44 R-L

American Dish Service

Ref. No.	Part No.	No. Req.	Description
1	287-6124	2	Support, Hood Top
2	285-6162	1	Filter Screen Weldment, Rinse Pump
3	285-6115	2	Hood End Shield Weldment
N/S	385-6116	Opt-2	Vent Weldment, Hood End Shield
4	284-6122	2	Rod, Curtain 5/16" x 20.5" Lg
5	299-1001	2	Curtain 21" Wide x 17" Tall
6	299-1002	2	Curtain 23" Wide x 11" Tall
7	284-6121	2	Rod, Curtain 5/16" x 23.5" Lg
8	285-6124	1	Door Weldment, Front Access
N/S	287-6123	2	Door Guide, SS
9	285-6139	1	Handle Weldment, Front Access Door
10	285-6125	1	Latch Weldment, Door
11	285-6132	1	Spacer Weldment, Scrap Trap
N/S	289-6602	2	Gasket, Scrap Trap Spacer
12	285-6123	2	Screen, Weldment Tank
13	098-8008	2	Cotter Pin, 3/32 x 1" SS
14	285-6172	1	Plug Weldment, Rinse Stand Tube
N/S	281-6210		Drain Stand Tube with O-Ring, Rinse Tank
15	285-6121	1	Screen Weldment, Wash R-L, Large
16	286-6179	1	Cover, Wash Manifold
17	285-6122	1	Screen Weldment, Wash Small
18	289-6611	2	Gasket, 'O' Ring Wash/Rinse Taper
19	285-6174	1	Filter Weldment, Wash Pump, w/Taper
N/S	281-6211		Filter, Wash Pump with O-Ring
20	289-9109	1	Tray, Scrap Trap, Complete
21	289-9114	1	Support, Scrap Trap
22	289-9110	1	Scrap Trap
23	286-6182	1	Guard, Wash Magnet
24	285-6151	4	Front Panel Mount Weldment, Lower
25	285-6120	2	Panel Weldment, Front
26	285-6118	1	Frame Weldment, R-L
27	285-6119	1	Drip Chute Weldment
N/S	289-6601	1	Gasket, Drip Chute
28	285-6117	1	Pan Weldment, R-L

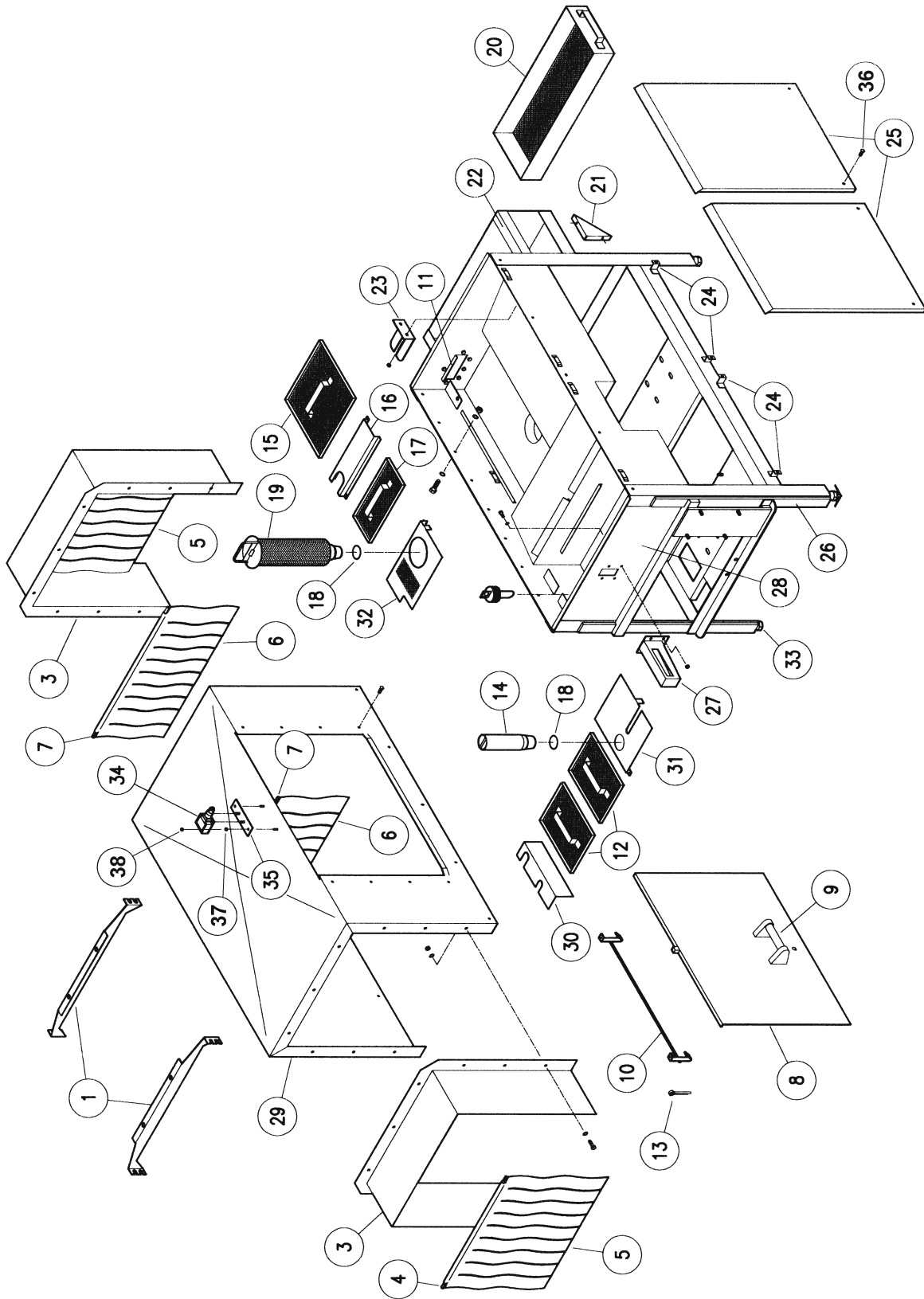

261-0200
 Cabinet Assembly
 ADC-44 R-L

American Dish Service

Ref. No.	Part No.	No. Req.	Description
29	285-6114	1	Hood Weldment, R-L
30	285-6126	1	Cover Weldment, Rinse Float, R-L
31	286-6176	1	Plate, Rinse Stand Tube, R-L
32	286-6174	1	Plate, Wash Pump Filter, R-L
33	099-1024	4	Bullet Feet
34	099-4502	1	Switch, Door Cut-Off
35	285-6103	1	Bracket, Door Cut-Off
N/S	285-6131	1	Cover, Transfer Chute, Weldment
36	098-1414	4	Bolt, 1/4-20 x 1/2", TH, SS
37	098-2507	2	Locknut, 1/4-20, SS
38	098-2301	2	Locknut, 10-32, SS
N/S	286-6247	OBS	Baffles, Hood End Shield Vent, OBSOLETE

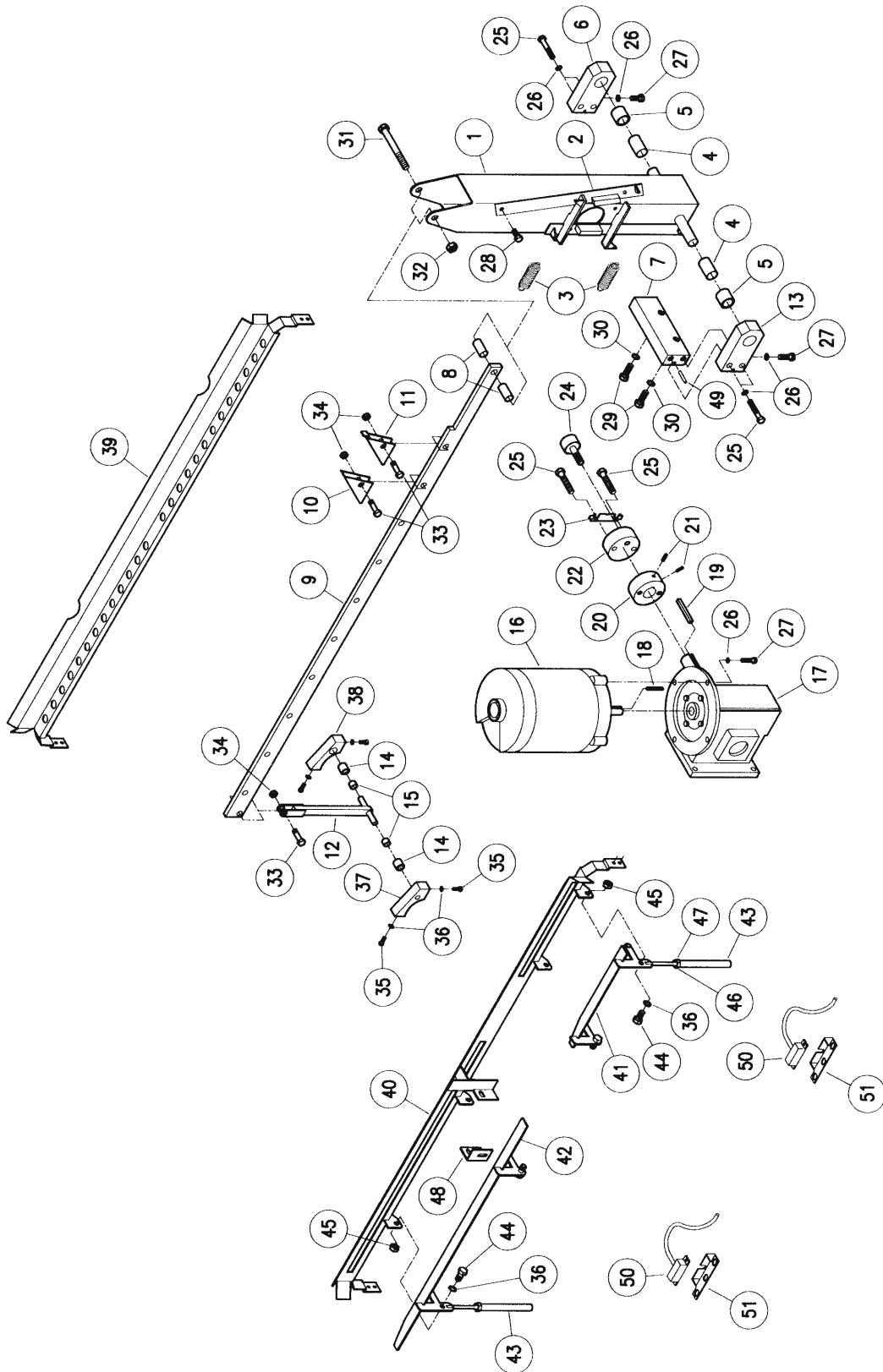

268-0600

Conveyor Drive & Tray Track
Control, ADC-44 L-R

American Dish Service

Ref. No.	Part No.	No. Req.	Description
1	285-6133	1	Rocker Arm Weldment
2	285-6134	2	Slip Clutch Bar Weldment
3	298-3001	2	Spring, Slip Clutch
4	284-6142	2	Spacer, Rocker Arm
5	298-4001	2	Bushing, Rocker Arm, 1" OD x 3/4" ID x 7/8" Lg
6	284-6141	1	Block, Pillow Bushing, RH
7	284-6139	1	Block, Base, Pillow Bushing
8	284-6149	2	Spacer, Conveyor Connecting Bolt
9	284-6138	1	Bar, Conveyor
N/S	284-6187	Opt.	Bar, Side Loader Conveyor
N/S	285-6187	Opt.	Guide Weldment, Side Loader Bar
10	285-6136	8	Dog Weldment, Conveyor
11	285-6137	2	Exit Dog Weldment, Conveyor
N/S	285-6138	Opt.	Side Loader Dog Weldment, Conveyor
12	285-6135	1	Idler Arm Weldment
13	284-6140	1	Block, Pillow Bushing LH
14	298-4002	2	Bushing, Idler Arm, 5/8" OD x 3/8" ID x 5/8" Lg
15	284-6143	2	Spacer, Idler Arm, 5/8" OD x 3/8" ID x 3/8" Lg
16	291-1003	1	Motor 1/3 HP, 3PH
N/S	291-1007	Opt.	Motor 1/3 HP, 1PH
N/S	299-1008	1	Cover, Conveyor Drive Motor w/Screws
17	291-1004	1	Gear Box (53:1)
N/S	291-1008	Opt.	Gear Box (60:1)
18	284-6201	1	Key, Conveyor Drive Motor
19	284-6137	1	Key, Cam Block
20	284-6134	1	Cam Block (A) Gear Box Side
21	098-1441	2	Screw, Set, 1/4-20 x 1/2" Lg
22	284-6135	1	Cam Block (B) Cam Follower Side
23	286-6189	1	Bolt Lock, Cam Follower
24	281-6201	1	Bearing, Cam Follower
25	098-1611	4	Bolt, 3/8-16 x 2" Lg, HH, SS
26	098-2710	10	Washer, 3/8", Split, SS
27	098-1614	6	Bolt, 3/8" x 1", HH, SS
28	098-1506	2	Bolt, 5/16-18 x 3/4" Lg, HH, SS

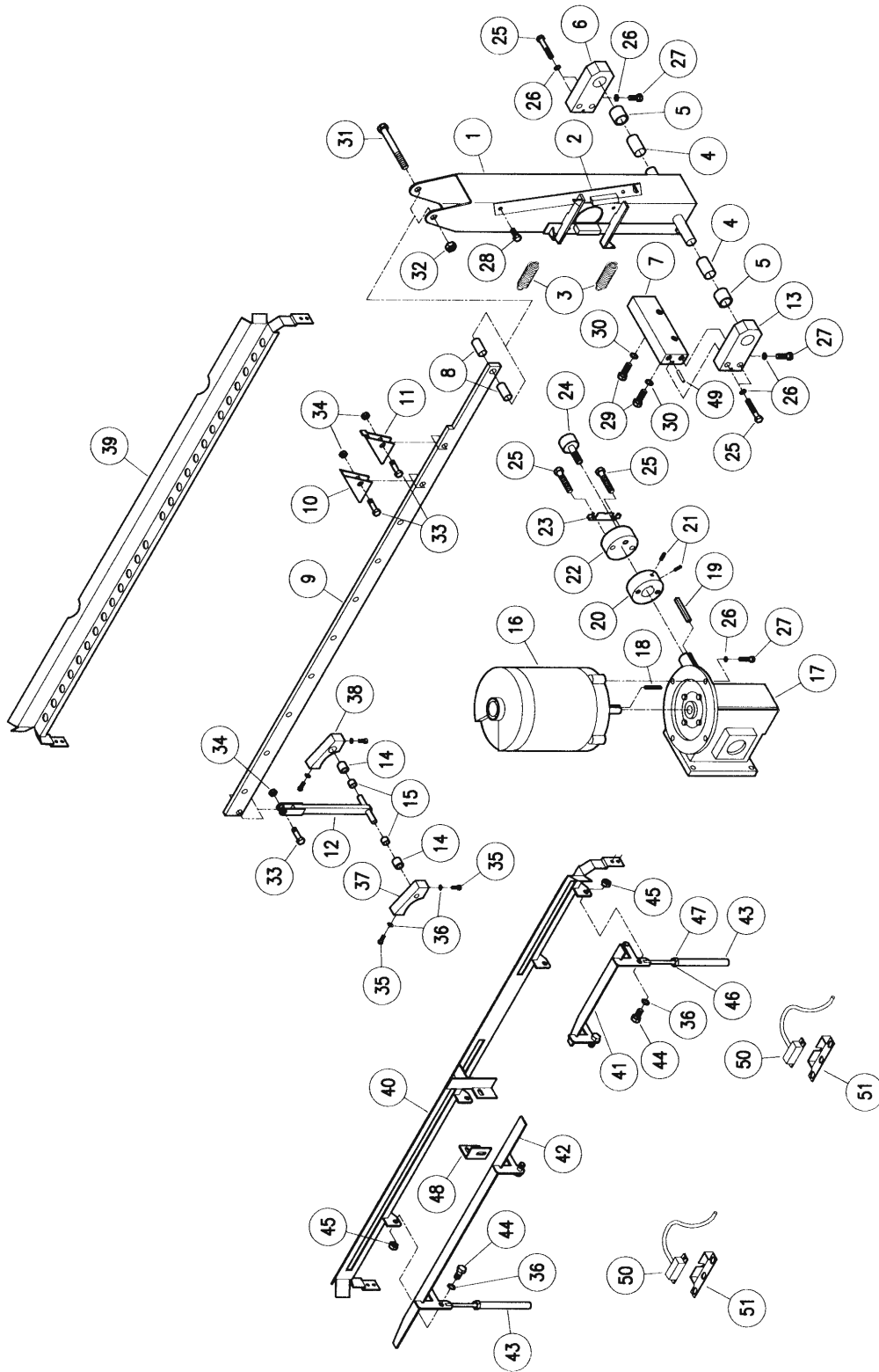

268-0600

Conveyor Drive & Tray Track
Control, ADC-44 L-R

American Dish Service

Ref. No.	Part No.	No. Req.	Description
29	098-1802	2	Bolt, 1/2-13 x 1 1/4" Lg, HH, SS
30	098-2802	2	Washer, 1/2", Split, SS
31	098-1801	1	Bolt, 1/2-13 x 4" Lg, HH, SS
32	098-2801	1	Locknut, 1/2"-13
33	098-1612	11	Dog Bolt, 3/8-16 x 1 1/8" with 3/4" Shoulder
34	098-2708	11	Locknut, 3/8-16 SS
35	098-1424	4	Bolt, 1/4-20 x 3/8" Lg, HH, SS
36	098-2404	12	Washer, 1/4", SS
37	084-6130	1	Bushing Mount, Idler Arm (A)
38	084-6131	1	Bushing Mount, Idler Arm (B)
39	285-6133	1	Tray Track Weldment, Rear, L-R
40	285-6112	1	Tray Track Weldment, Front L-R
41	285-6108	1	Tray Track Sequence Bar Weldment, Rinse
42	285-6107	1	Tray Track Sequence Bar Weldment, Wash
43	285-6109	2	Magnet Weldment, Tray Track Sequence Bar
44	098-1428	4	Bolt, 1/4-20 x 1" Lg, HH, SS
45	098-2407	4	Locknut, 1/4-20, SS
46	098-2506	2	Washer, 5/16 Split, SS
47	098-2501	2	Locknut, 5/16-18, SS
48	286-6178	2	Bracket, Tray Track Mount
49	098-8009	2	Dowel Pin 3/16" x 1" Lg, SS
50	291-3011	2	Switch, Reed
51	286-6113	2	Bracket, Reed Switch
N/S	288-1047	Rep	Conveyor Drive Motor and Gear Box Assembly
N/S	288-1053	Tool	Tool, Conveyor Clutch Spring

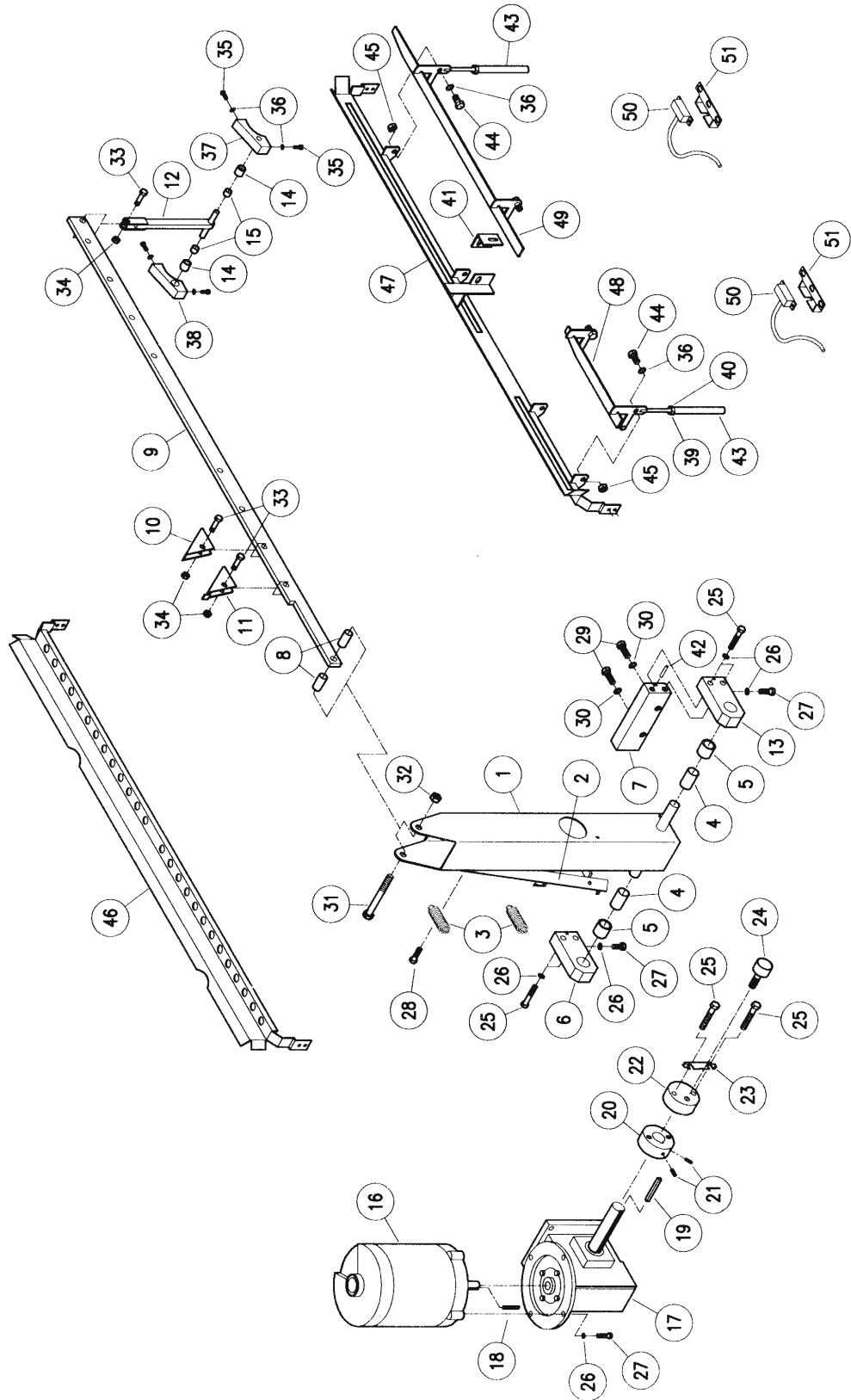

268-0700

Conveyor Drive & Tray Track
Control, ADC-44 R-L

American Dish Service

Ref. No.	Part No.	No. Req.	Description
1	285-6133	1	Rocker Arm Weldment
2	285-6134	2	Slip Clutch Bar Weldment
3	298-3001	2	Spring, Slip Clutch
4	284-6142	2	Spacer, Rocker Arm
5	298-4001	2	Bushing, Rocker Arm, 1" OD x 3/4" ID x 7/8" Lg
6	284-6140	1	Block, Pillow Bushing LH
7	284-6139	1	Block, Base, Pillow Bushing
8	284-6149	2	Spacer, Conveyor Connecting Bolt
9	284-6138	1	Bar, Conveyor
N/S	284-6187	Opt.	Bar, Side Loader Conveyor
N/S	285-6787	Opt.	Guide Weldment, Side Loader bar
10	285-6136	8	Dog Weldment, Conveyor
11	285-6137	2	Exit Dog Weldment, Conveyor
N/S	285-6138	Opt.	Side Loader Dog Weldment, Conveyor
12	285-6135	1	Idler Arm Weldment
13	284-6141	1	Block, Pillow Bushing RH
14	298-4002	2	Bushing, Idler Arm, 5/8" OD x 3/8" ID x 5/8" Lg
15	284-6143	2	Spacer, Idler Arm, 5/8" OD x 3/8" ID x 3/8" Lg
16	291-1003	1	Motor, 1/3 HP 3ph
N/S	291-1007	Opt.	Motor, 1/3 HP 1ph
N/S	288-1008	1	Cover, Conveyor Drive Motor w/Screws
17	291-1004	1	Gear Box (53:1)
N/S	291-1008	Opt.	Gear Box (60:1) Old Style
18	284-6201	1	Key, Conveyor Drive Motor
19	284-6137	1	Key, Cam Block
20	284-6134	1	Cam Block (A) Gear Box Side
21	098-1441	2	Screw, Set, 1/4-20 x 1/2" Lg
22	284-6135	1	Cam Block (B) Cam Follower Side
23	286-6189	1	Bolt Lock, Cam Follower
24	281-6201	1	Bearing, Cam Follower
25	098-1611	4	Bolt, 3/8-16 x 2" Lg, HH, SS
26	098-2710	10	Washer, 3/8" Split, SS
27	098-1614	6	Bolt, 3/8" x 1 HH, SS
28	098-1506	2	Bolt, 5/16-18 x 3/4 " Lg, HH, SS

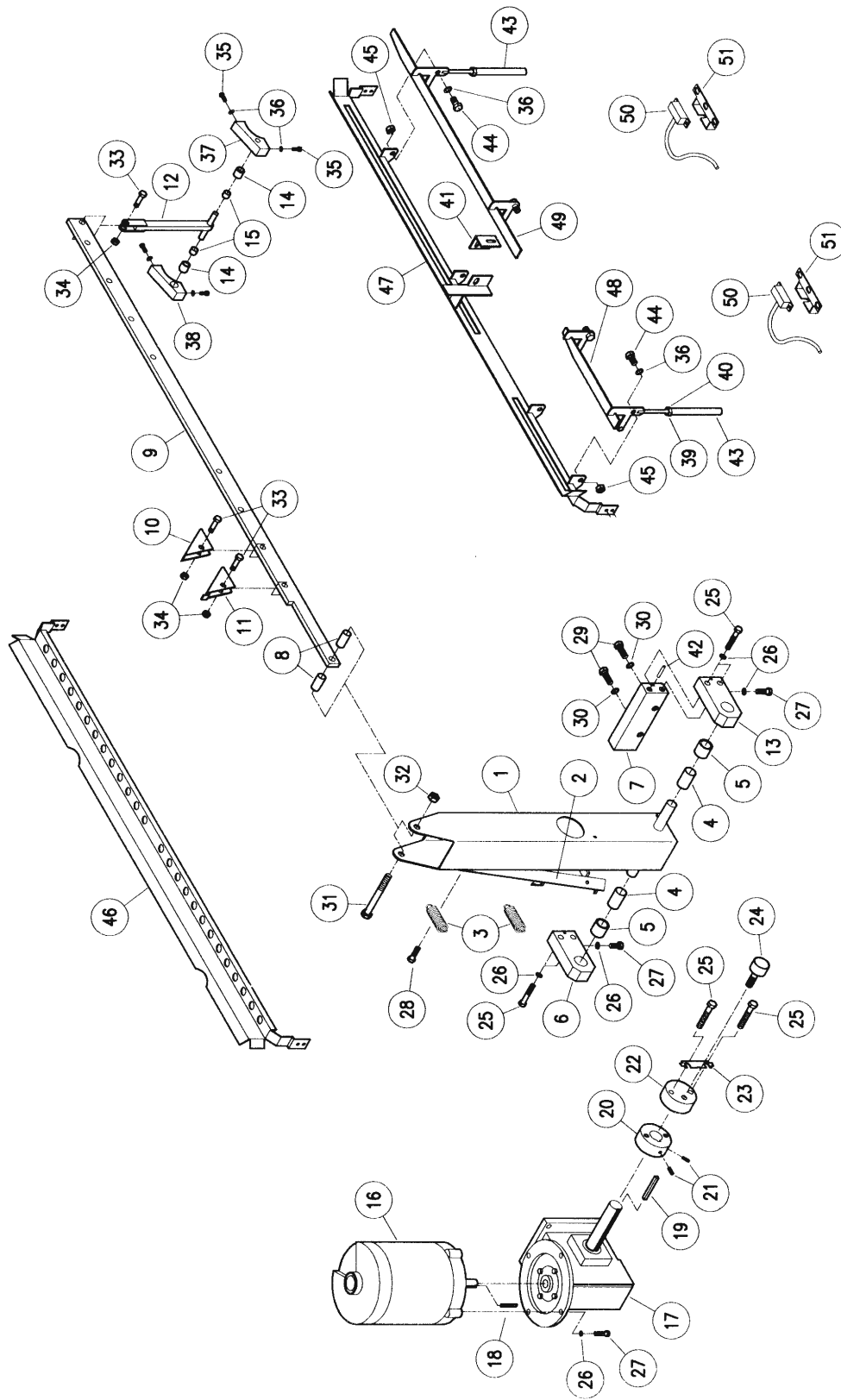

268-0700

Conveyor Drive & Tray Track
Control, ADC-44 R-L

American Dish Service

Ref. No.	Part No.	No. Req.	Description
29	098-1802	2	Bolt, 1/2-13 x 1 1/4" Lg HH, SS
30	098-2802	2	Washer, 1/2" Split, SS
31	098-1801	1	Bolt 1/2-13 x 4" Lg HH, SS
32	098-2801	1	Locknut, 1/2"-13
33	098-1612	11	Dog Bolt 3/8-16 x 1 1/8" Lg with 3/4" Shoulder
34	098-2708	11	Nut, Lock, 3/8-16, SS
35	098-1424	4	Bolt, 1/4-20 x 3/8" Lg HH, SS
36	098-2404	12	Washer, 1/4", SS
37	284-6132	1	Bushing Mount, Idler Arm (C)
38	284-6133	1	Bushing Mount, Idler Arm (D)
39	098-2506	2	Washer, 5/16 Split, SS
40	098-2501	2	Nut, Lock 5/16-18 SS
41	286-6178	2	Bracket, Tray Track Mount
42	098-8009	2	Dowel Pin 3/16" x 1" Lg, SS
43	285-6109	2	Magnet Weldment, Tray Track Sequence Bar
44	098-1428	4	Bolt, 1/4-20 x 1" Lg HH, SS
45	098-2407	4	Nut, Lock, 1/4-20, SS
46	285-6111	1	Tray Track Weldment, Rear R-L
47	285-6110	1	Tray Track Weldment, Front R-L
48	285-6106	1	Tray Track Weldment Sequence Bar, Rinse R-L
49	285-6105	1	Tray Track Weldment Sequence Bar, Wash R-L
50	291-3011	1	Switch, Reed
51	286-6113	1	Bracket, Reed Switch
N/S	288-1047	Rep	Conveyor Drive Motor and Gear Box Assembly
N/S	288-1053	Tool	Tool, Conveyor Clutch Spring

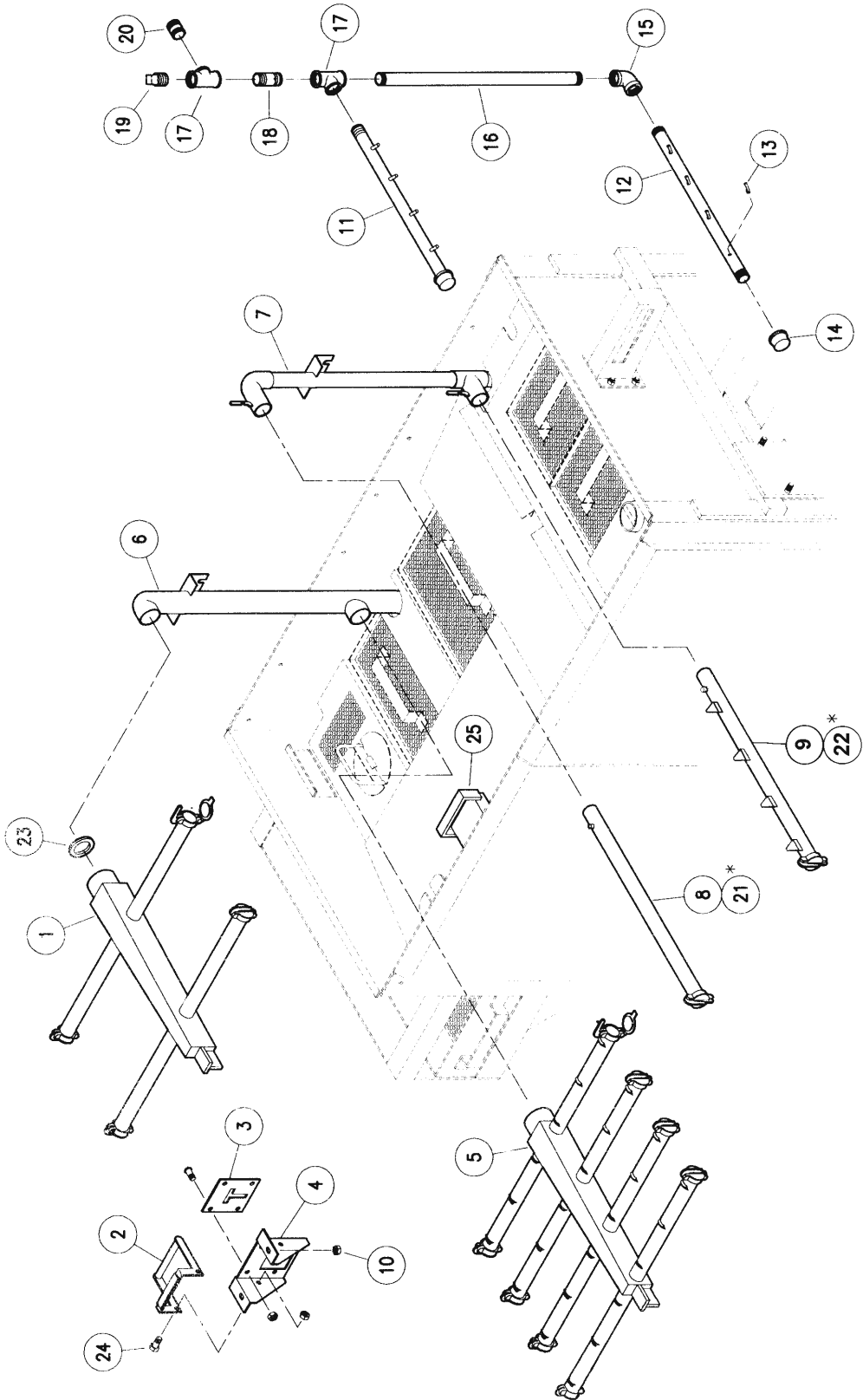

265-0300L-R / 265-0400R-L
 Spray System Assemblies
 ADC-44

American Dish Service

Ref. No.	Part No.	No. Req.	Description
1	285-6159	1	Upper Wash Arm Weldment Assembly
2	285-6129	1	Handle Weldment, Upper Wash Arm Mount
3	285-6128	1	Tee Plate Weldment, Upper Wash Arm
4	286-6177	1	Bracket, Upper Wash Arm Mount
5	285-6156	1	Lower Wash Arm Weldment Assembly
6	285-6155	1	Manifold Weldment, Inside Wash
7	285-6166	1	Manifold Weldment, Inside Pumped Rinse
8	285-6168	1	Spray Arm Weldment, Pumped Rinse Upper, L-R
9	285-6167	1	Spray Arm Weldment, Pumped Rinse Lower, L-R
10	098-2507	8	Locknut, ¼-20, SS
N/S	285-6158	14	Spray Arm Endcap Weldment
11A	281-6208	1	Spray Arm, Final Rinse, Upper, L-R, SS Jets
11B	281-6106		Spray Arm, Final Rinse, Upper, L-R, Poly Jets
11C	281-6104		Spray Arm, Final Rinse, Upper, R-L, SS Jets
11D	281-6202		Spray Arm, Final Rinse, Upper, R-L, Poly Jets
11E	285-6142		Spray Arm Weld., Final Rinse, Upper, L-R, Arm Only
11F	285-6140		Spray Arm Weld., Final Rinse, Upper, R-L, Arm Only
12A	281-6209	1	Spray Arm, Final Rinse, Lower, L-R, SS Jets
12B	281-6207		Spray Arm, Final Rinse, Lower, L-R, Poly Jets
12C	281-6205		Spray Arm, Final Rinse, Lower, R-L, SS Jets
12D	281-6203		Spray Arm, Final Rinse, Lower, R-L, Poly Jets
12E	285-6143		Spray Arm Weld., Final Rinse, Lower, L-R, Arm Only
12F	285-6141		Spray Arm Weld., Final Rinse, Lower, R-L, Arm Only
13A	284-6146	8	Jets, Final Rinse Spray Arm, SS
13B	284-6145		Jets, Final Rinse Spray Arm, Poly
14	292-1011	2	Cap, ½" FPT, SS
15	292-1003	1	Fitting, ½" FPT, 90° Elbow, SS
16	292-3009	1	Nipple, ½" x 21 ½" Lg, SS
17	292-1002	2	Fitting, ½" x ½" x ½" Tee, SS
18	292-3010	1	Nipple, ½" x 3", SS
19	292-1012	1	Plug, ½" MPT, SS
20	292-3001	1	Nipple, ½" x 1 ½" Lg, SS
21	285-6170		Spray Arm, Pumped Rinse, Upper, R-L
22	285-6169		Spray Arm, Pumped Rinse, Lower, R-L

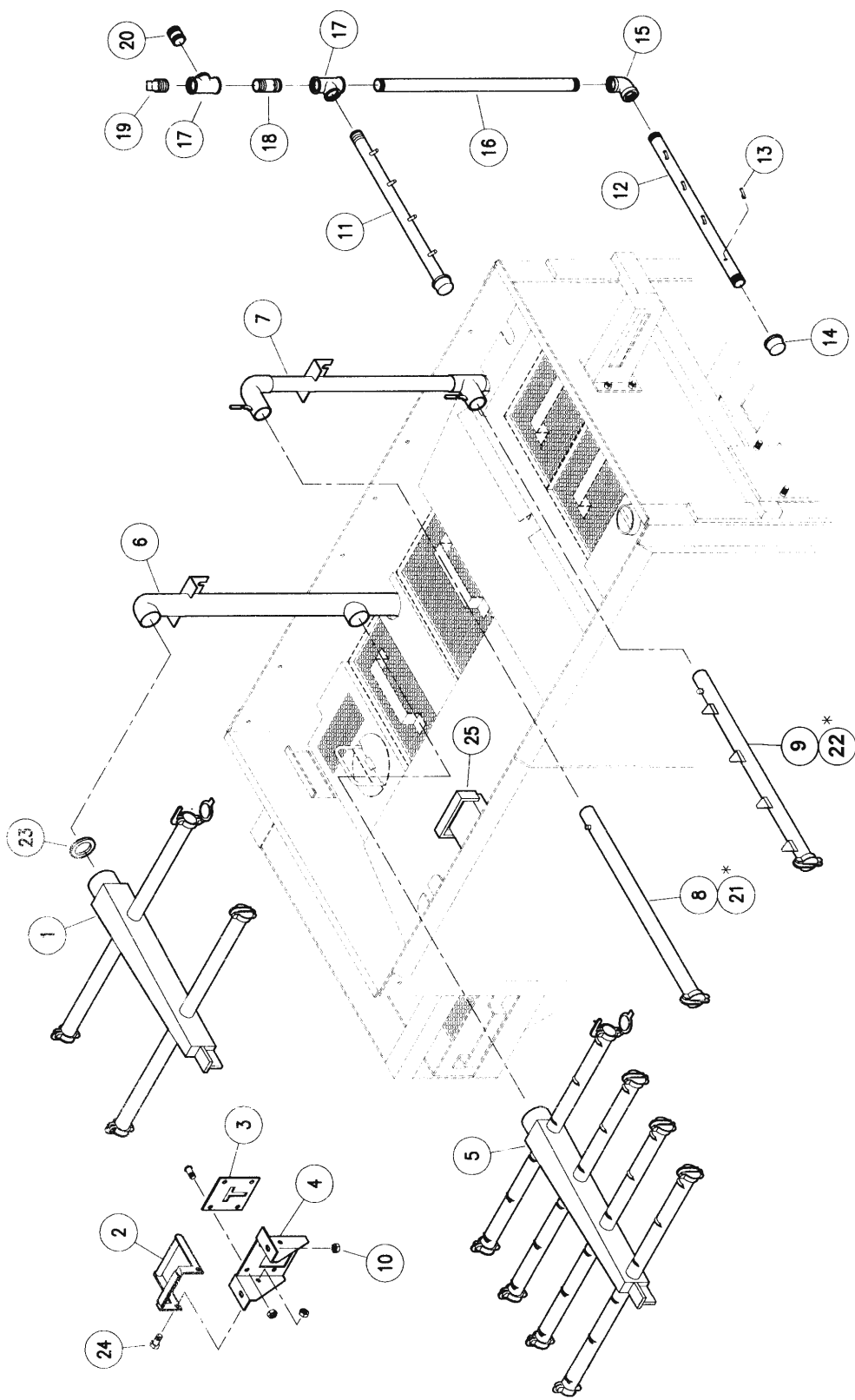

265-0300L-R / 265-0400R-L
 Spray System Assemblies
 ADC-44

American Dish Service

Ref. No.	Part No.	No. Req.	Description
23	289-6608	2	Gasket, O-Ring, Wash Arm
24	098-1423	2	Bolt, 1/4-20 x 1/2", SS, HH
25	285-6130	1	Handle Weldment, Wash Arm Mount, Lower
N/S	288-1057	Tool	Tool, Spray Arm Pressure Test w/Gauge
N/S	288-1055	Tool	Tool, Spray Arm Pressure Tester without Gauge

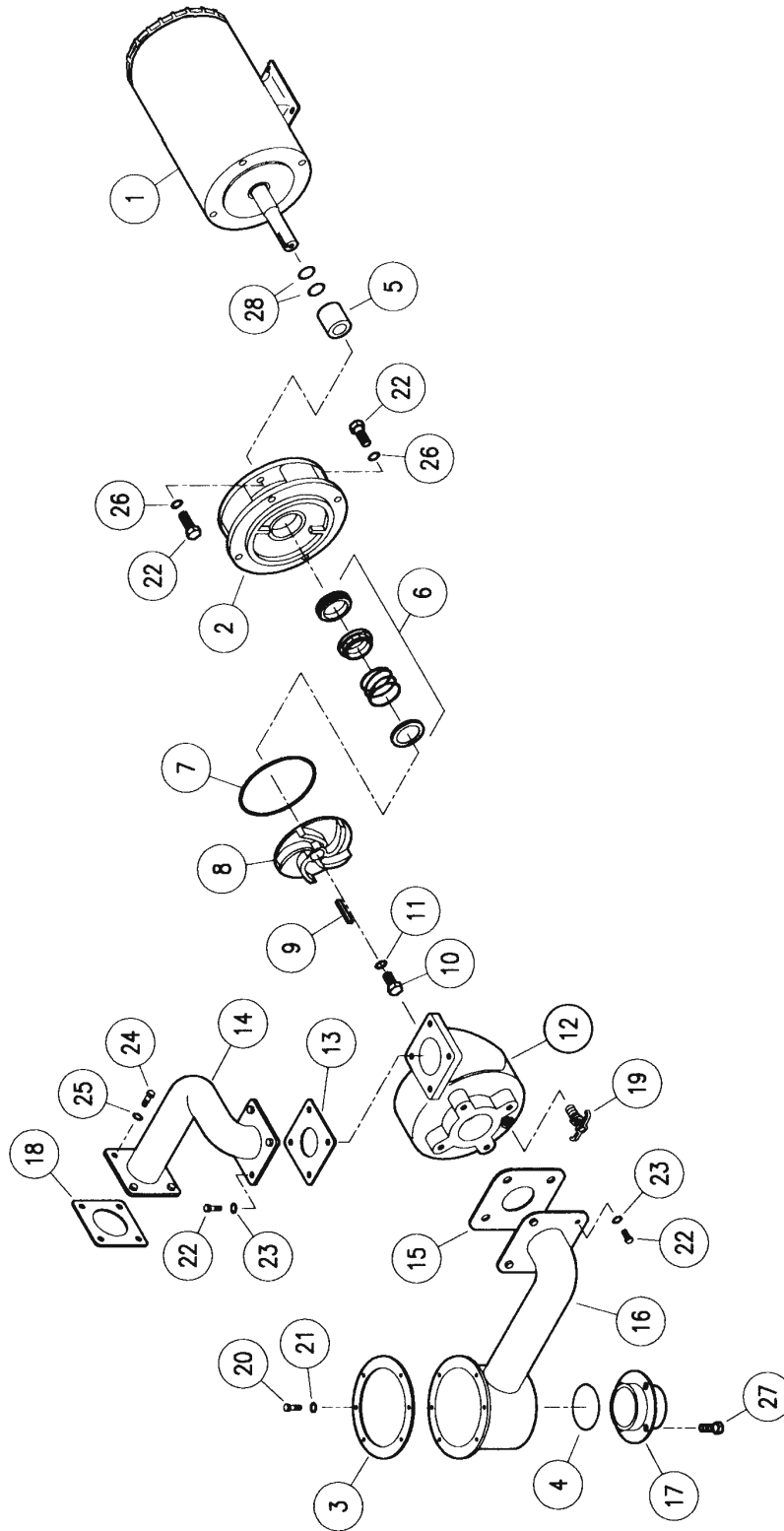

263-0100

Wash Pump Assembly
ADC-44 L-R/R-L

American Dish Service

Ref. No.	Part No.	No. Req.	Description
1	291-1002	1	Motor, 3HP, 3 Phase w/Shaft
	291-1006		Motor, 3HP, 1 Phase w/Shaft
2	282-6301	1	Housing, Rear, Wash
3	089-6601	1	Gasket, Sump
4	289-6606	1	Gasket, O-Ring, Drain Socket Flange
5	284-6203	1	Sleeve, Wash Pump Shaft
6	292-2001	1	Seal, Wash Pump
7	289-6603	1	Gasket, Wash Pump O-Ring
8	282-6303	1	Impeller, Wash Pump
9	284-6151	1	Key, Wash Pump Impeller
10	098-1613	1	Bolt, 3/8-16 x 1" Lg, HH, SS, w/Lock Strip
11	098-2711	1	Washer, 3/8" ID x 1" OD x .103 Thick, SS
12	282-6302	1	Cover, Wash Pump
13	289-6604	1	Gasket, Wash Pump Discharge Flange
14	285-6153	1	Discharge Tube Weldment, Wash Pump
15	289-6605	1	Gasket, Wash Pump Intake Flange
16	285-6154	1	Intake Tube, Sump Weldment, Wash Pump
17	285-6157	1	Drain Socket Weldment, Wash
18	289-6607	2	Gasket, Wash Tank Flange
19	292-1013	1	Petcock, 1/4" MPT
20	098-1423	6	Bolt, 1/4-20 x 1/2" Lg, HH, SS
21	098-2404	6	Washer, 1/4" SS
22	098-1614	16	Bolt, 3/8-16 x 1" Lg, HH, SS
23	098-2711	8	Washer, 3/8" ID x 1" OD x .103 Thick, SS
24	098-1514	4	Bolt, 5/16-18 x 1 1/2" Lg, HH, SS
25	098-2509	8	Washer, 5/16, SS
26	098-2710	8	Washer, 3/8" Split, SS
27	098-1502	4	Bolt, 5/16-18 x 1/2", HH, SS
N/S	288-1048	Rep	Pump Assy. Less Cover, Wash, 3HP, 3 Phase
N/S	288-1056	Rep	Pump Assy. Less Cover, Wash, 3HP, 1 Phase
28	289-6618	2	O-Ring, Wash Pump Shaft Sleeve
N/S	098-2510	4	Washer, 5/16" SS Neobond (For Inside of Pump Discharge)

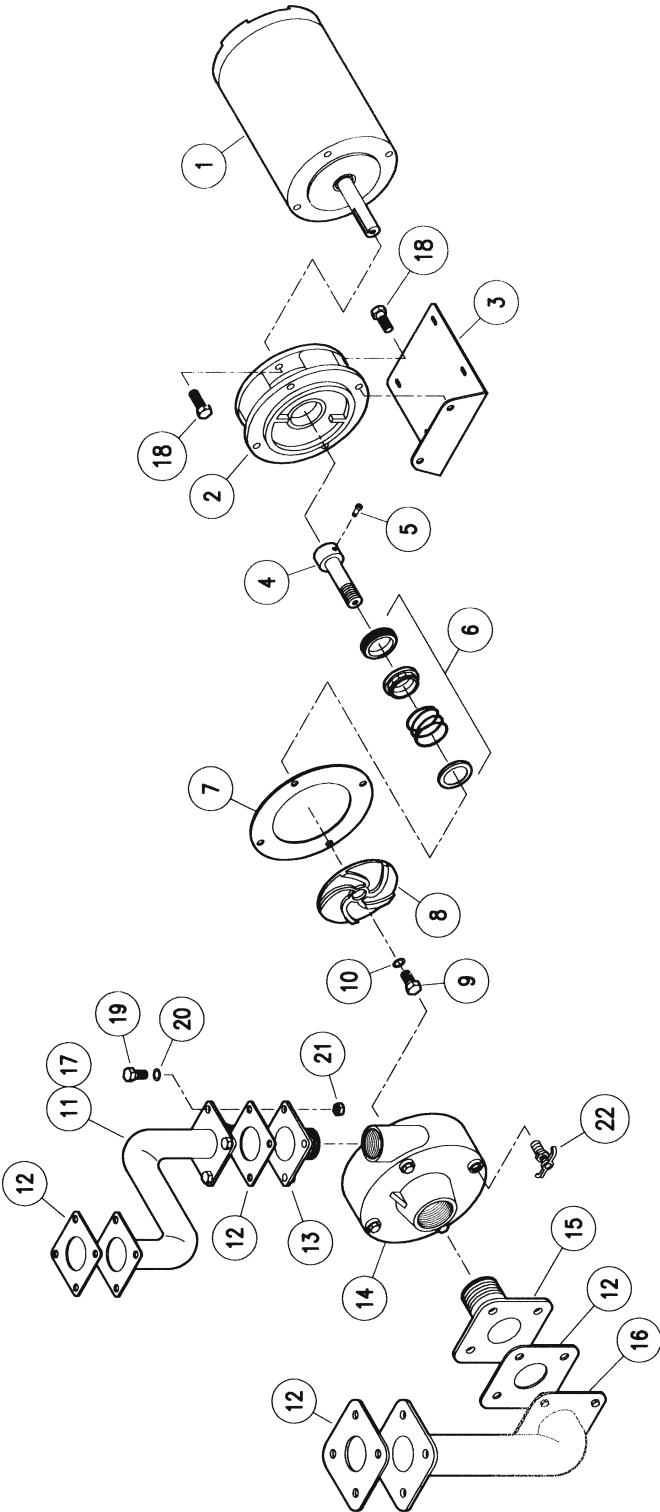

263-0300L-R / 263-0400R-L

Rinse Pump Assembly
ADC-44

American Dish Service

Ref. No.	Part No.	No. Req.	Description
1	291-1003	1	Motor, 1/3 HP, 3 Phase
	291-1007		Motor, 1/3 HP, 1 Phase
2	282-6307	1	Housing, Pumped Rinse Rear
3	286-6250	1	Plate, Pump Rinse Motor Support, w/Pad
4	284-6163	1	Pump Shaft, Pumped Rinse
5	098-1442	2	Set Screw, 1/4-20 x 3/8" Lg
6	292-2002	1	Seal, Pumped Rinse Pump
7	289-6609	1	Gasket, Pumped Rinse Pump
8	282-6308	1	Impeller, Pumped Rinse Pump
9	098-1443	1	Bolt, 1/4-28 x 3/8" Lg HH, SS
10	098-2413	1	Washer, .285 ID x .625 OD x .086 Thick, SS
11	285-6164	1	Discharge Tube Weldment L-R
12	289-6610	4	Gasket, Pumped Rinse Pump Flange
13	285-6165	1	Discharge Flange Assembly Weldment
14	282-6306	1	Cover, Pumped Rinse Pump
15	285-6161	1	Intake Flange Weldment Assembly
16	285-6160	1	Intake Tube Weldment
17	285-6163	1	Discharge Tube Weldment R-L
18	098-1607	8	Bolt, 3/8-16 x 7/8" HH, SS
19	098-1426	16	Bolt, 1/4-20 x 3/4" HH, SS
20	098-2404	32	Washer, 1/4", SS
21	098-2507	16	Locknut, 1/4-20, SS
22	092-1002	1	Petcock, 1/8" MPT
N/S	288-1040	Rep	Kit, Rinse Pump Seal
N/S	288-1049	Rep	Pump Assy. Less Cover, Rinse, 1/3HP, 3 Phase
N/S	288-1050	Rep	Pump Assy. Less Flanges, Rinse, 1/3HP, 3 Phase
N/S	288-1061	Rep	Pump Assy. Less Cover, Rinse, 1/3HP, 1 Phase

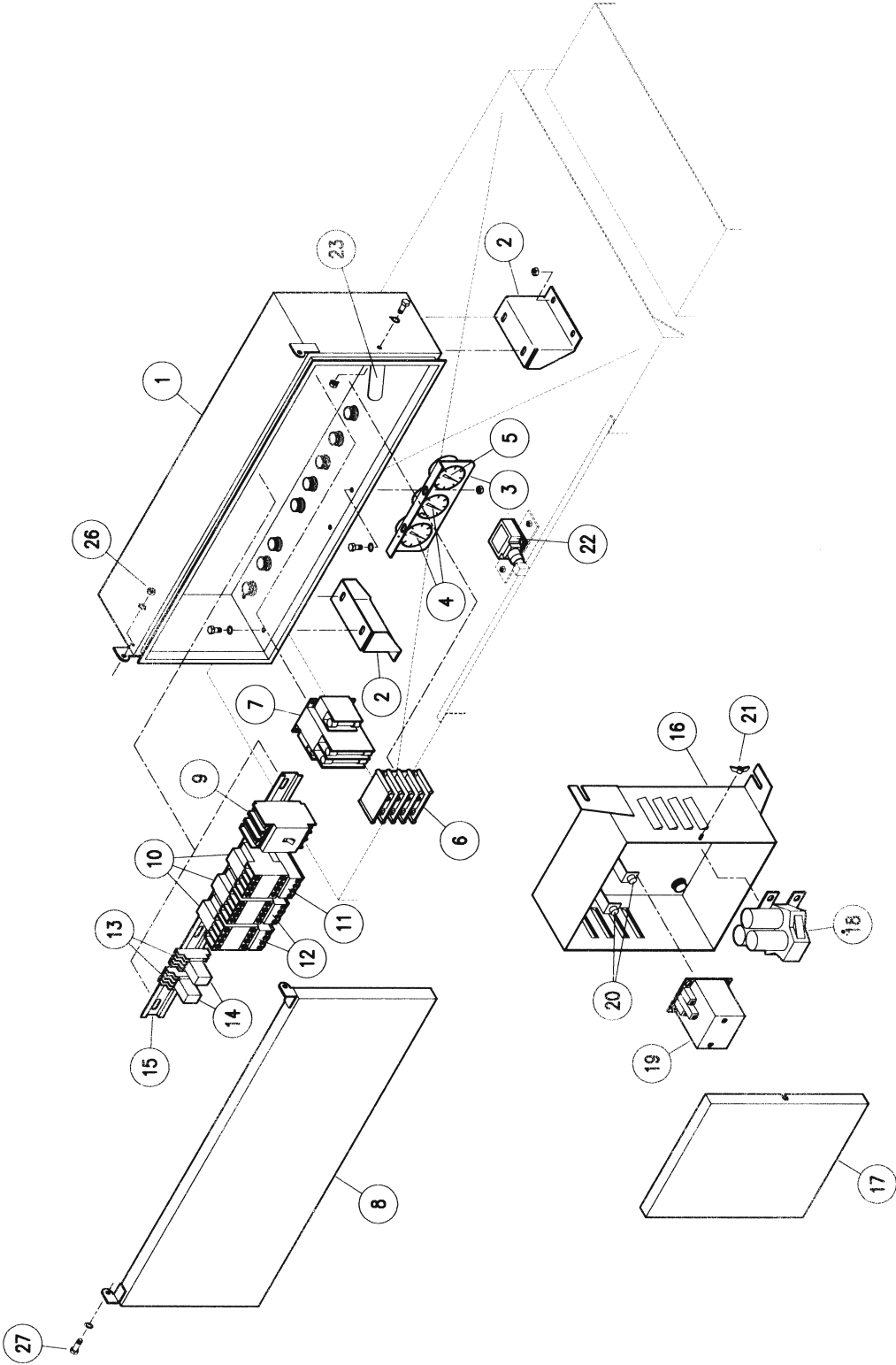

264-0100L-R / 264-0200R-L

Control System Assembly
ADC-44**American Dish Service**

Ref. No.	Part No.	No. Req.	Description
1	285-6101	1	Control Box Weldment
2	286-6111	2	Control Box Mounts
3	286-6180	1	Bracket, Temperature Gauge
4	299-1005	2	Gauge, Temperature, Wash & Rinse Tank
5	299-1004	1	Gauge, Temperature, Final Rinse
6A	291-5101	1	Terminal Block (Main 4 Pole)
6B	291-5105	Opt.	Terminal Block (Main 2 Pole Single Phase)
7	291-3004	1	Transformer w/Jumper Wires
N/S	291-9101	2	Fuse, 3 amp, Primary
N/S	291-9102	1	Fuse, 1 6/10 amp, Secondary
8	285-6102	1	Cover Weldment, Control Box
9A	291-3010	1	Circuit Breaker, 50 amp, 3 Pole
9B	391-3003	Opt.	Circuit Breaker, 20 amp, 2 Pole
9C	391-3004	Opt.	Circuit Breaker, 60 amp, 2 Pole
10	291-3001	3	Contactor
11A	291-3002	1	Overload, 3HP, 3 Phase
11B	291-3017	Opt.	Overload, 3HP, 1 Phase
12A	291-3003	2	Overload, 1/3HP, 3 Phase
12B	291-3018	Opt.	Overload, 1/3HP, 1 Phase
13	291-3009	2	Socket, Relay
14	291-3005	2	Relay, 110V, Double Pole
15	291-9104	1	Din Rail, 18" Lg
16	285-6104	1	Power Box Weldment
17	287-6104	1	Cover, Power Box
18	291-3006	1	Relay, Mercury, 50 amp, Wash Heater
19	291-3007	1	Relay, Mercury, 30 amp, Rinse Heater
20	091-7006	2	Light, Heater
21	098-2308	2	Wingnut, 1/4-20, SS
22	099-4502	1	Switch, Door Cut-Off
23	284-6101	1	Bar, Control Box Safety
24	091-3008	1	Switch, Master
25	291-9105	1	Boot, Master Switch Cover
N/S	291-7101	1	Light, Indicator
26	098-2507	13	Locknut, 1/4-20

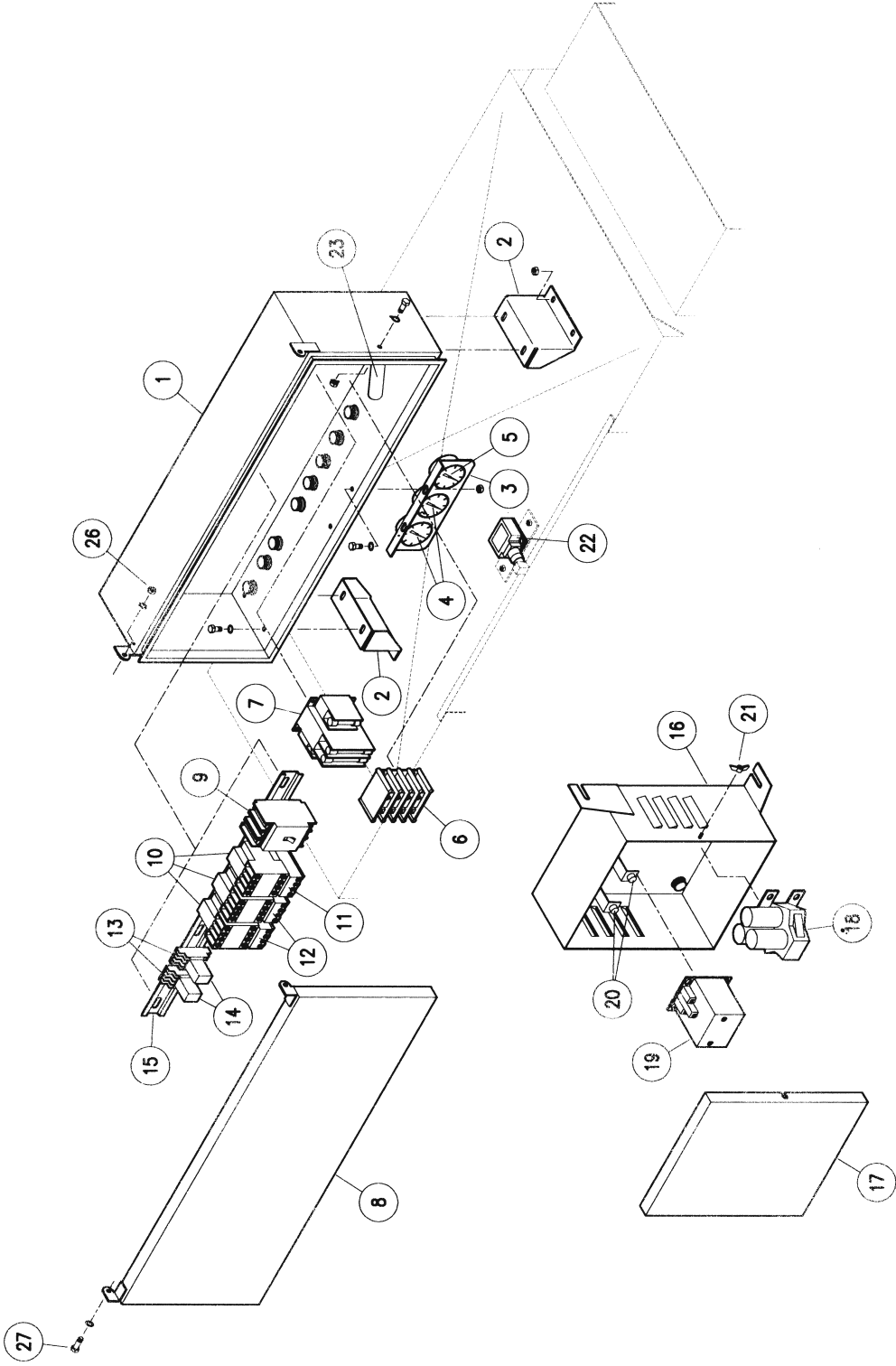

264-0100L-R / 264-0200R-L

Control System Assembly
ADC-44

American Dish Service

Ref. No.	Part No.	No. Req.	Description
27	098-1423	2	Bolt, ¼-20 x ½" HH, SS
N/S	291-3008	1	Relay, Time Delay, 6 Second
N/S	291-3011	2	Switch, Reed
N/S	291-3016	Opt.	Counter, Rack Timer
N/S	286-6219	Opt.	Bracket, Rack Timer Counter
N/S	291-5102	1	Ground Lug
N/S	286-6107	1	Plate, 110V Terminal Block
N/S	291-5104	2	Block, Terminal, Chemical Dispenser, 2 Pole
N/S	091-5010	1	Block, Terminal, 6 Pole (White Wires)
N/S	291-5106	1	Block, Terminal, 6 Pole (Black Wires)
N/S	288-1044	Opt.	Kit, Table Limit Switch
N/S	288-1051	Opt.	Kit, Rack Timer
N/S	289-0001	1	Nameplate, ADS
N/S	289-6617	1	Gasket Material, Control Box, 78" (Cut from 289-6615)
N/S	289-9204	1	Decal, NSF (244 Racks)
N/S	289-9212	Rep.	Decal, NSF (216 Racks) (Replacement Part)
N/S	289-9217	Rep.	Decal Set, ADC-44 (Replacement Part)
N/S	289-9301	1	Wall Chart, Cleaning, ADS
N/S	291-3015	Opt.	Switch Only, Table Limit
N/S	291-5103	1	Wire Harness, 3 Phase
N/S	291-5107	Opt.	Wire Harness, 1 Phase
N/S	291-9108	3	Shield for Contactor Overload (Anti-Tamper)
N/S	299-1010	Rep.	Temp Gauge Cover, Screw-On
N/S	096-1002	1	Control Box Lock
N/S	096-1008	1	Control Box Dummy Lock
N/S	091-4152	1	Bell Box
N/S	091-4004	1	Bell Box Cover
N/S	286-6181	1	Bracket, Conduit (Rear of Machine)
N/S	289-9201	1	Decal, Label Set (Blue & Gray) (Temp. Gauge Bracket)
N/S	289-9202	1	Decal, Label Set (Yellow & Black, Inside Control Box)
N/S	289-9206	1	Decal, Temp Gauge, Final Rinse, 180°
N/S	289-9209	1	Decal, Wiring Diagram

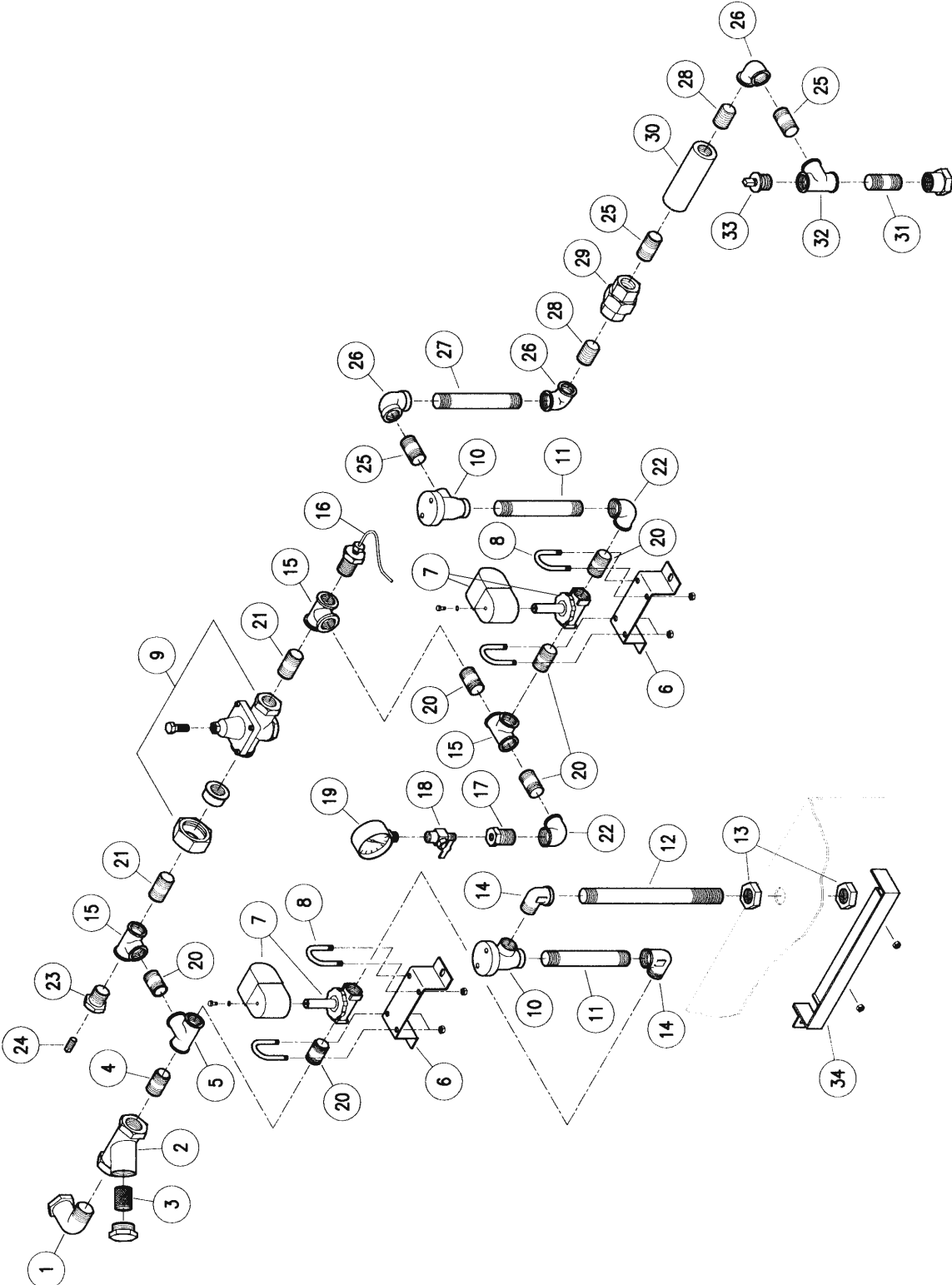

265-0500L-R / 265-0600R-L

Water Inlet Assembly ADC-44

American Dish Service

Ref. No.	Part No.	No. Req.	Description
1	092-1074	1	Fitting, 3/4" Street Elbow, 90°
2	092-9006	1	Y-Line Strainer, 3/4"
3	092-9008		Line Strainer Screen, 3/4"
4	092-1073	1	Nipple, 3/4" Close, Brass
5	092-1107	1	Tee, 3/4" x 1/2" x 1/2" Brass
6	286-6191	2	Bracket, Plumbing
7	092-5015	2	Valve, Water Solenoid
8	098-9027	4	Bolt, 'U', 1/4-20
9	292-5001	1	Pressure Regulator, 1/2"
10	092-5045	2	Vacuum Breaker, 1/2"
11	292-3007	2	Nipple, 1/2" x 6" Lg, Brass
12	292-3008	1	Nipple, 1/2" x 9 1/2" Lg, Brass
13	292-1006	2	Pipe Locknut, 1/2" FPT, Brass
14	092-1006	2	Elbow, 1/2" Street, 90°
15	292-1001	3	Tee, 1/2" x 1/2" x 1/2", Brass
16	299-1004	1	Temperature Gauge, Final Rinse
17	299-1005	1	Reducer Bushing, 1/2" MPT x 1/4" FPT, Brass
18	292-5002	1	Service Cock
19	299-1003	1	Pressure Gauge
20	292-3002	6	Nipple, 1/2" x 1 1/2" Lg, Brass
21	292-3004	2	Nipple, 1/2" x 2" Lg, Brass
22	292-1014	2	Fitting, 1/2" Elbow, 90°
23	292-1007	1	Reducer Bushing, 1/2" MPT x 1/8" FPT
24	292-1008	1	Plug, 1/8" MPT, Brass
25	292-3001	3	Nipple, 1/2" x 1 1/2" Lg, BSS
26	292-1003	3	Fitting, Elbow, 1/2" FPT, SS
27	292-3008	1	Nipple, 1/2" x 6" Lg, SS
28	292-3003	2	Nipple, 1/2" x Close, SS
29	292-1004	1	Union, 1/2", SS
30A	284-6148	1	Mixing Chamber, SS
30B	284-6147	Opt.	Mixing Chamber, Polymer
31	292-3010	1	Nipple, 1/2" x 3" Lg, SS
32	292-1002	1	Tee, 1/2" x 1/2" x 1/2", SS

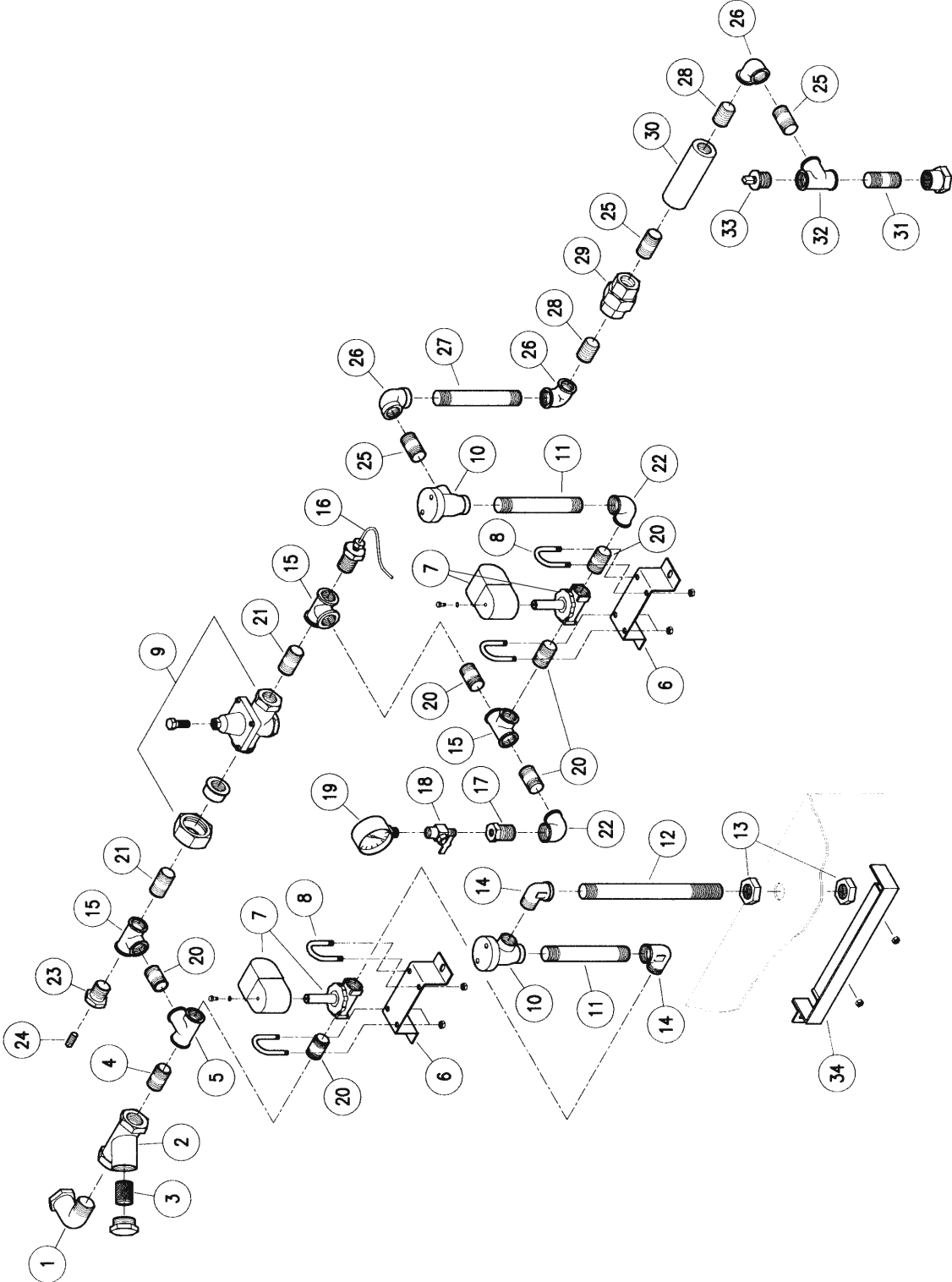

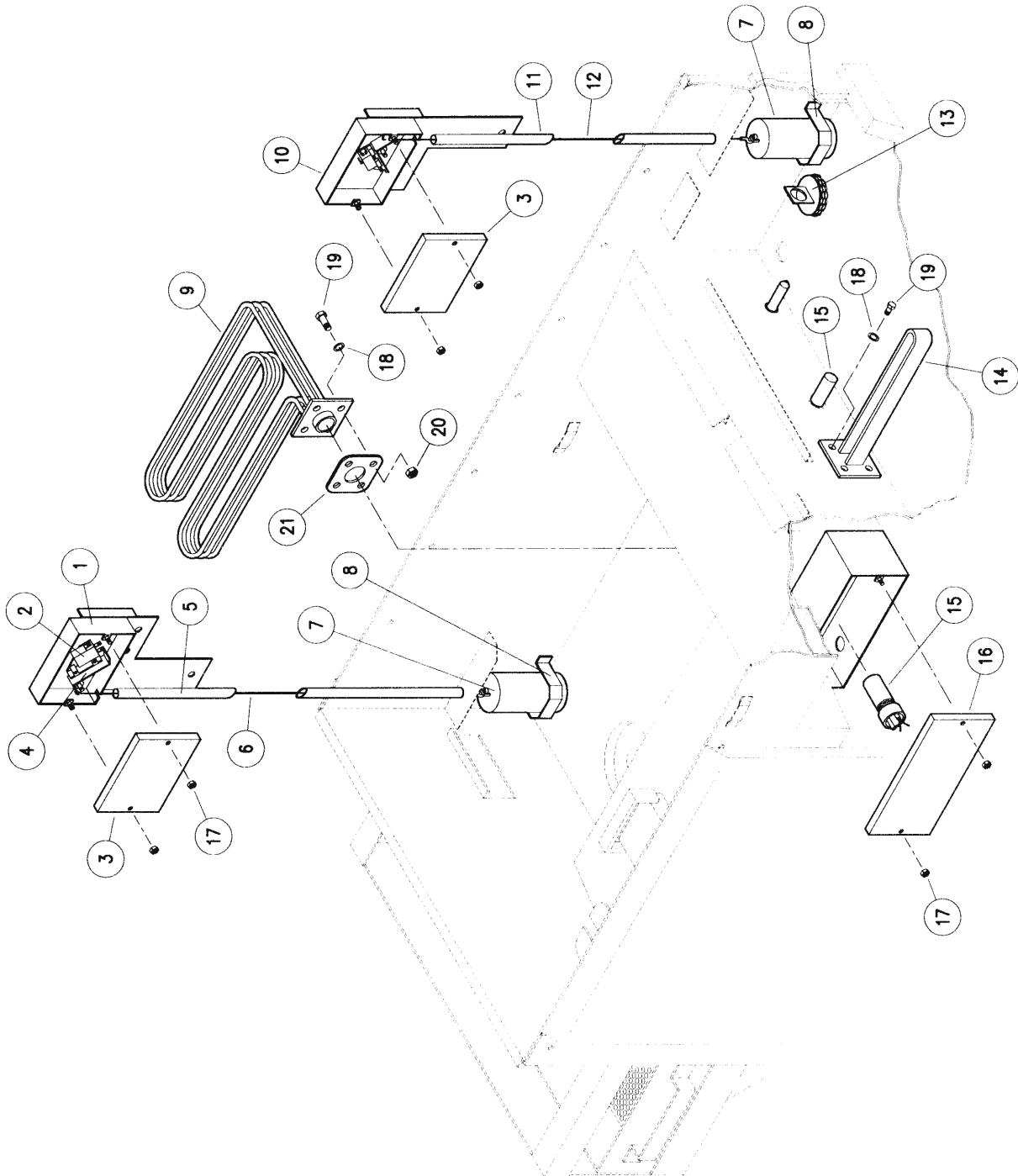

268-0800

Heater & Water Level Control
ADC-44 L-R

American Dish Service

Ref. No.	Part No.	No. Req.	Description
1	285-6177	1	Float Box Weldment, LH
2A	291-3014	2	Float Switch, w/Holder & Button
2B	291-3013		Float Switch, Switch Only
2C	291-9109		Float Switch Holder
2D	291-9110		Float Switch Holder Button
3	286-6246	2	Float Box Cover
4	285-6179	2	Float Switch Flipper Weldment
5	285-6180	1	Float Rod Tube Weldment , Wash, L-R
6	286-6248	1	Float Rod, Wash
7	285-6176	2	Float Weldment
8	286-6199	2	Bracket, Float Retainer
9A	291-9001	1	Heater, Wash, 12KW, 3 Phase
9B	391-9002		Heater, Wash, 8KW, 1 Phase
10	285-6178	1	Float Box Weldment, RH
11	285-6181	1	Float Rod Tube Weldment Rinse, L-R
12	286-6249	1	Float Rod Rinse
13	285-6162	1	Filter Weldment, Pumped Rinse Pump
14A	291-9003	1	Heater, Rinse, 2.25KW 3 Phase
14B	291-9004		Heater, Rinse, 2.25KW 1 Phase
15	291-3012	2	Thermostat
16	286-6175	2	Heater Box Cover
17	098-2201	8	Locknut, 8-32, SS
18	098-2510	16	Washer, 5/16, SS Neobond
19	098-1516	8	Bolt, 5/16-18 x 1" LG HH, SS
20	098-2501	8	Locknut, 5/16-18
21	289-6613	2	Gasket, Heater
N/S	286-6231	2	Flange, Heater Sandwich (1 1/2" Hole)
N/S	286-6241	4	Washer, Float Switch Rod, 3/4" OD x 1/8" ID, SS

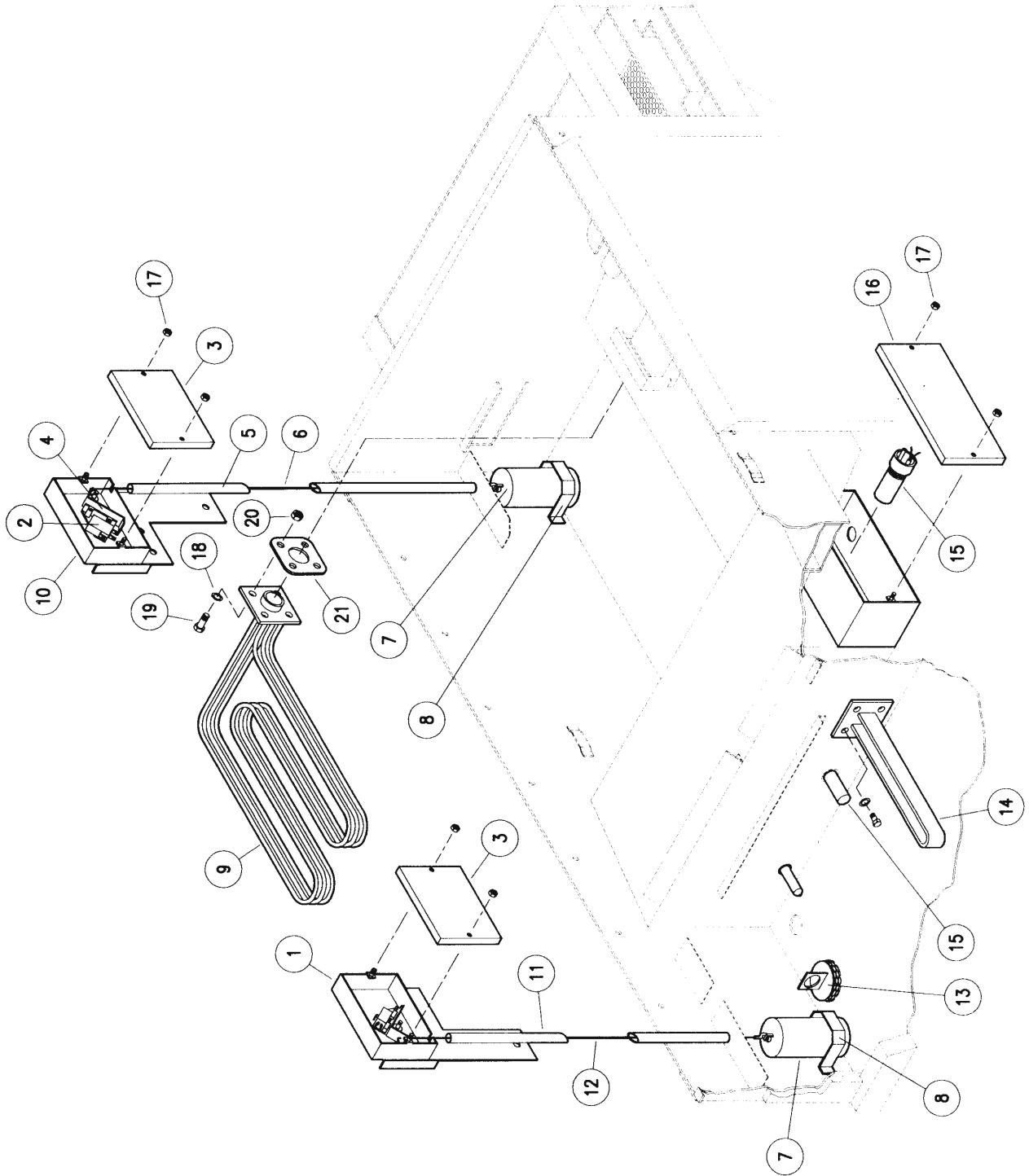

268-0900

Heater & Water Level Control
ADC-44 R-L

American Dish Service

Ref. No.	Part No.	No. Req.	Description
1	285-6177	1	Float Box Weldment, LH
2A	291-3014	2	Float Switch, w/Holder & Button
2B	291-3013		Float Switch Only
2C	291-9109		Float Switch Holder
2D	291-9110		Float Switch Holder Button
3	286-6246	2	Float Box Cover
4	285-6179	2	Float Switch Flipper Weldment
5	285-6148	1	Float Rod Tube Weldment, Wash, R-L
6	286-6248	1	Float Rod, Wash
7	285-6176	2	Float Weldment
8	286-6199	2	Bracket, Float Retainer
9A	291-9001	1	Heater, Wash, 12KW, 3 Phase
9B	391-9002		Heater, Wash, 8KW, 1 Phase
10	285-6178	1	Float Box Weldment, RH
11	285-6149	1	Float Rod Tube Weldment, Rinse, R-L
12	286-6249	1	Float Rod, Rinse
13	285-6162	1	Filter Weldment, Pumped Rinse Pump
14A	291-9003	1	Heater, Rinse, 2.25KW, 3 Phase
14B	291-9004		Heater, Rinse, 2.25KW, 1 Phase
15	291-3012	2	Thermostat
16	286-6175	2	Heater Box Cover
17	098-2201	8	Locknut, 8-32, SS
18	098-2510	16	Washer, 5/16, SS, Neobond
19	098-1516	8	Bolt, 5/16-18 z 1" Lg HH, SS
20	098-2501	8	Locknut, 5/16-18
21	289-6613	2	Gasket, Heater
N/S	286-6231	2	Flange, Heater Sandwich (1 1/2" Hole)
N/S	286-6241	4	Washer, Float Switch Rod, 3/4" OD x 1/8" ID

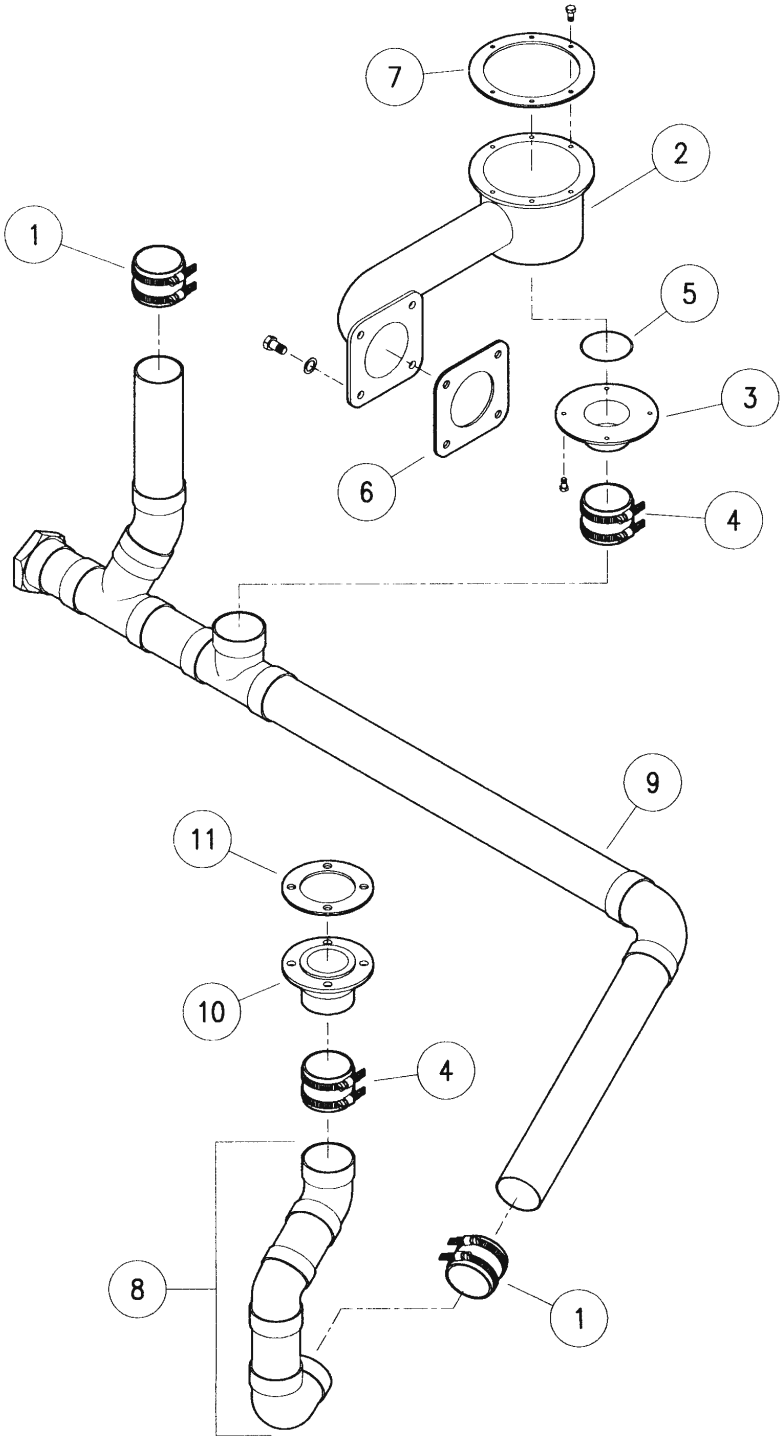

266-0500L-R / 266-0600R-L
Drain System Assembly
ADC-44

American Dish Service

Ref. No.	Part No.	No. Req.	Description
1	292-1029	2	No-Hub Connector, Fitting to Pipe
2	285-6154	1	Intake Tube, Sump Weldment, Wash Pump
3	285-6157	1	Drain Socket Weldment, Wash
4	292-1028	2	No-Hub Connector, Pipe to Pipe
5	289-6606	1	Gasket, O-Ring, Drain Socket Flange
6	289-6605	1	Gasket, Wash Pump Intake Flange
7	089-6601	1	Gasket, Sump
8	285-6191	1	2" Copper Drain Weldment, Rinse Side
9A	285-6189	1	2" Copper Drain Weldment, Wash Side, L-R
9B	285-6190		2" Copper Drain Weldment, Wash Side, R-L
	266-0300		Drain Assembly, Copper with No-Hubs, L-R
	266-0400		Drain Assembly, Copper with No-Hubs, R-L
10	285-6175	1	Rinse Drain Socket Weldment
11	289-6612	1	Gasket, Rinse Drain Socket Flange

American Dish Service

*Manufacturer of low and high temperature
Commercial Dishwashers and Glasswashers*

900 Blake Street
Edwardsville, Kansas 66111
Ph:(913) 422-3700
Fax:(913) 422-6630