



Anetsberger Brothers, Inc.

180 North Anets Drive • Northbrook, Illinois 60062 • 847-272-0770 • Fax 847-272-1943
For ANETS Factory Warranty Service • 800-837-2638



ANETS
FRYER
Model
SLG40

**Installation,
User Operation,
&
Maintenance
Manual**

SLG40 shown on standard 6" legs

⚠ DANGER

Improper installation, adjustment, alteration, service, or maintenance can cause property damage, injury or death. Read the installation, operating and maintenance instructions thoroughly before installing or servicing this equipment.

⚠ FOR YOUR SAFETY

DO NOT store or use gasoline or other flammable vapors or liquids in the vicinity of this or any other appliance.

⚠ WARNING

After installation of this equipment, immediately contact your local gas supplier to obtain information about what action to take whenever any person smells gas. *Post this information in a prominent location.*

Keep this Manual in a Convenient Location for Reference



The Anets SilverLine
Quality Equipment For The Restaurant, Supermarket, and Bakery Industries



Form: I-302
Rev. 9/03
Price: \$20.00 US

 **DANGER**

Read these specifications, Code Requirements, Installation Requirements, Installation Instructions, and Operating Instructions very carefully. Failure to follow the Instructions could cause the fryer to malfunction. A fryer malfunction can result in property damage, serious bodily injury, or death.

CONTENTS

Shipping Container Inspection 3

Fryer Gas Supply Specifications 3

Fryer Electrical Specifications 4

Figure 1 - Fryer Wiring Diagram 4

Code Requirements 4

Figure 2 - Fryer Site Installation Requirements 5

Installation Requirements 6

 Fryer Restraining Device Installation Instructions 6

 Leg Installation Instructions 7

Figure 3 - Leg Installation 7

 Leg Leveling Instructions 7

 Caster Installation Instructions 8

Figure 4 - Caster Installation 8

 Caster Leveling Instructions 8

Gas Connection Instructions 9

Fryer Operation Recommendations 10

Fryer Operating Instructions 11

 Fryer Preparation For Use 11

Figure 5 - Draining The Kettle 11

 Lighting Procedure 12

Figure 6 - Gas Safety Valve & Control Knob Positions 12

 Shutdown Procedure 12

 Food Product Frying Time Chart 13

 Daily Cleaning Procedure 14

 Monthly Maintenance Instructions 15

Fryer Troubleshooting Guide 16 - 19

Fryer Warranty 20

SHIPPING CONTAINER INSPECTION

1. Carefully examine the shipping carton for external damage. When damage is noted, notify the delivery carrier immediately. **Save all packing materials for damage claim examination.**

2. If no external damage is noted, remove the shipping carton from the fryer and examine the

fryer carefully for damage. Place the fryer in a safe location, if damage is noted, so that the freight damage claims adjuster can examine the fryer.

3. Save the shipping container for use during leg/caster installation. Refer to the Installation Instructions for that procedure.

Model Covered By This Manual

Model	Features
SLG40	Stainless Steel Fryer Kettle

Standard Accessories furnished in the shipping carton for this fryer include:

2 Fryer Baskets 1 Screen
 4 Adjustable Legs 1 Drain Valve Extension
 1 Basket Hanger 1 Flue Deflector

Optional Accessories available for this fryer include:

Single or Triple Fryer Baskets
 1 Set (4) of Casters

FRYER GAS SUPPLY SPECIFICATIONS

Please make sure that your desired fryer location has gas supply factors that are suitable for this product:

INPUT REQUIRED: 90,000 BTU/Hr *	Natural Gas	Propane
MANIFOLD PRESSURE	3½" W.C. **	10" W.C.
SUPPLY PRESSURE ***	6" W.C., minimum	11" W.C., minimum

* - Rating is based on sea level operation. Reduce rating 4% for each 1000 feet above sea level.

** - "W.C. = Inches, Water Column.

*** - Measure Supply Pressure when all other gas-powered equipment is operating.

Gas Supply Inlet Pipe must be ½" standard gas line. The gas supply inlet line should be as straight as possible (fewest bends or elbows) to obtain the highest available gas pressure at the fryer. Locate this inlet line horizontally at the center of the desired fryer location, approximately 8¼" above the floor.

NOTE: Using a flexible inlet line permits variation in the gas supply line location, both horizontally and vertically.

Anets fryers are only for use with the type of gas specified on the spec plate. If a fryer requires modification to use a gas other than that which is identified on the fryer spec plate, contact your Anets representative or call (800) 837-2638.

FRYER ELECTRICAL SPECIFICATIONS

The ANETS Fryer Model SLG40 requires no external electric power source.

Figure 1 is the wiring diagram of an ANETS SLG40 Fryer.

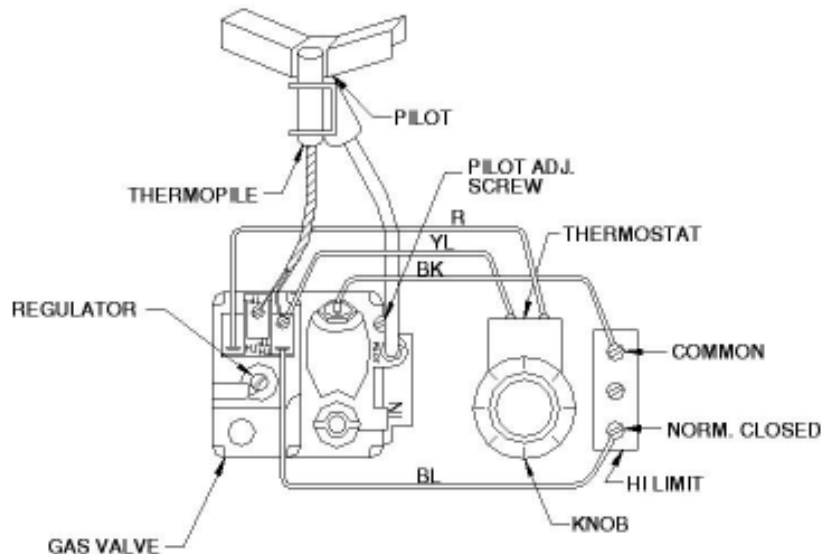

Figure 1. Fryer Model SLG40 Wiring Diagram

CODE REQUIREMENTS

IMPORTANT: Read the Code Requirements and ALL installation instructions carefully, before starting the installation. Contact the factory (800/ 837-2638) if any problems or questions arise.

The fryer installation must conform with local codes, or in the absence of local codes, with the National Fuel Gas Code, ANSI Z223.1 (latest edition); the Natural Gas Installation Code, CAN/CGA-B149.1 (latest edition); or the Propane Gas Installation Code, CAN/CGA-B149.2 (latest edition), as applicable, including:

- a. Disconnect the fryer and its individual shutoff valve from the gas supply piping system during any pressure testing of the gas supply system at test pressures in excess of ½ psig (3.45 kPa).
- b. Isolate the fryer from the gas supply piping system during any pressure testing of the gas supply system at test pressures equal to or less than ½ psig (3.45 kPa).
- c. For fryers utilizing floor casters, the fryer installation shall be made with a connector that complies with the Standard for Connectors for Movable Gas Appliances, ANSI Z21.69 (latest edition) or CAN/CGA 6.16 (latest edition), and a quick-disconnect device that complies with the Standard for Quick-Disconnect Devices for Use with Gas Fuel, ANSI Z21.41 or CAN/CGA 1-6.9 (latest edition).
- d. Restrict the movement of a caster-equipped fryer by using a limiting device (for example, a cable attached both to the fryer **and** to a fixture attached to the site structure) to avoid depending on the connector and the quick-disconnect device or its associated piping to limit fryer movement.

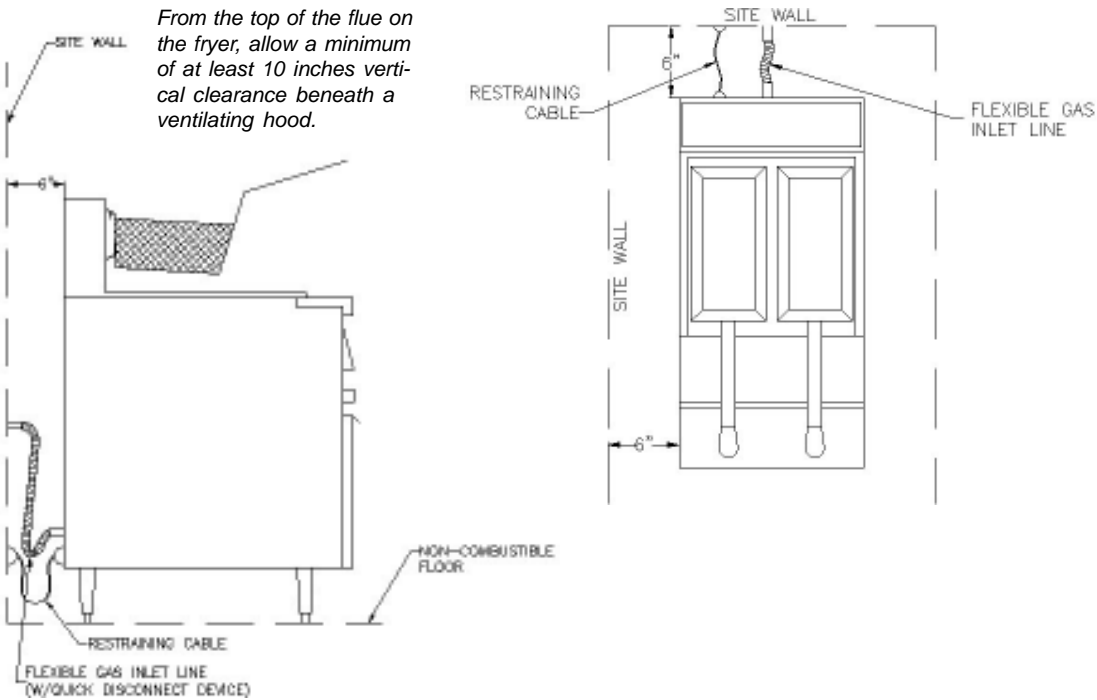

Figure 2. Fryer Model SLG40 Site Installation Requirements

CODE REQUIREMENTS (Continued)

- e. Install this fryer on a non-combustible floor with its back and sides *at least 6"* away from any combustible wall, as shown in Figure 2.

⚠ WARNING
Install this fryer under a ventilation hood that conducts combustion products outside the building. Venting must comply with ANSI/NFPA 96 (latest edition).

- f. Install this fryer in a location where adequate combustion and ventilation air is available. Keep the area directly in front of the fryer open for adequate air flow to the burners. **DO NOT** obstruct the flow of combustion and ventilation air.
- g. Keep the fryer area free and clear from combustibles and debris.
- h. Attach a restraining device to each fryer, to prevent the unit from tipping, which could cause splashing of hot liquid .

INSTALLATION REQUIREMENTS

Install the fryer in accordance with the preceding Code Requirements, as well as the following Installation Requirements.

1. DO NOT install this fryer in a mobile home, trailer, or recreational vehicle.
2. Install this fryer in a location that allows it to be moved away from other adjacent appliances for cleaning and maintenance.

NOTE: If the fryer is installed among a row of appliances (“banked”), with its only convenient movement forward, sufficient room must be available in front of the fryer to permit its separation from adjacent appliances for cleaning and maintenance.

3. Tightly fasten the legs (or casters) to the bottom of the fryer using the supplied hardware, to prevent the fryer from tipping, wobbling or rocking when it is in its desired location. Refer to the following **Leg Installation Instructions** or **Caster Installation Instructions** for leg or caster attachment and leveling information.

 **CAUTION:** Hood make-up air **MUST NOT** flow in a manner that restricts or impedes the natural flow of combustion or ventilation air.

4. Confirm that the air from the ventilation hood flowing near the fryer after installation is *NOT* blowing on the rear of the unit, to prevent affecting the burner flames and possibly causing control damage.

FRYER RESTRAINING DEVICE INSTALLATION INSTRUCTIONS

 **WARNING**
*Fryers **MUST** have a movement-limiting (restraining cable) device installed to prevent tipping that causes splashing or spilling its **HOT** contents.*

NOTE: This movement-limiting device is to be **furnished and installed** by the fryer’s installing contractor **before** the fryer is connected to the gas line at its desired location.

1. Install one restraining device connector securely into the structure wall directly behind the fryer’s desired location (Figure 2).
2. Install one restraining device connector on the rear panel of the fryer very close to the quick-disconnect device on the end of the fryer’s gas line.
3. Attach one end of the restraining cable to the wall connector. Attach the other end to the fryer connector.
4. Confirm that the fryer cannot move far enough away from the wall to cause excessive movement of the flexible gas line or its associated connectors.

INSTALLATION REQUIREMENTS (Continued)

LEG INSTALLATION INSTRUCTIONS

1. Flatten the shipping carton (after unpacking the fryer and its parts and accessories) for fryer surface protection during leg installation.
2. Position the side of the fryer flat on the carton, exposing the fryer bottom mounting brackets for leg installation, as shown in Figure 3.
3. Place the leg mounting plate flush against the mounting bracket on the fryer bottom.
4. Insert one mounting screw through the proper hole in the leg mounting plate and start it into the proper hole in the fryer mounting bracket.

LEG INSTALLATION INSTRUCTIONS (Continued)

5. Screw the mounting screw several turns into the mounting bracket.
6. Repeat steps 4 and 5 until all four mounting screws for each leg are in place.
7. Tighten the four mounting screws evenly and securely to hold the leg mounting plate against the fryer bottom mounting bracket.

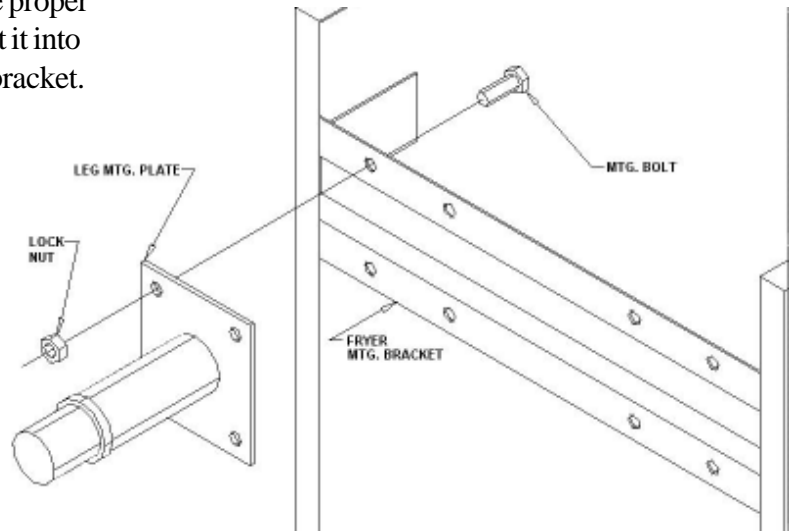

Figure 3. Typical Leg Installation

LEG LEVELING INSTRUCTIONS

1. Move the fryer to its desired location.

⚠ WARNING
The fryer MUST NOT tip, rock or wobble, to avoid splashing or spilling its HOT shortening contents during operation.

2. Turn the screw-type leg adjustment ends as necessary to level the fryer, until NO tipping, rocking, or wobbling is evident.
3. Perform the “**Fryer Restraining Device Installation Instructions.**”

INSTALLATION REQUIREMENTS (Continued)

CASTER INSTALLATION INSTRUCTIONS

1. Flatten the shipping carton (after unpacking the fryer and its parts and accessories) for surface protection during caster installation.
2. Position the side of the fryer flat on the carton, exposing the fryer bottom mounting brackets for caster installation, as shown in Figure 4.
3. Mount locking casters on the front of the fryer and fixed casters on the rear, by placing each caster mounting plate on the fryer bottom.
4. Insert one mounting bolt through the proper hole in the caster mounting plate and start it into the proper hole in the fryer mounting bracket.
5. Screw a locking nut several turns onto the mounting bolt.
6. Repeat steps 4 and 5 until all four mounting bolts for each leg are in place with locking nuts.
7. Tighten the four bolts evenly and securely to hold the caster mounting plate against the bottom of the fryer.

CASTER LEVELING INSTRUCTIONS

1. Move the fryer to its desired location.
2. Determine whether the fryer tends to wobble or rock when in its desired location. If it *does*, perform steps 3 through 9. If it does not, skip to step 10, then proceed to the **Installation Instructions**.

⚠ WARNING
The fryer MUST NOT tip, rock or wobble, to avoid splashing or spilling its HOT shortening contents during operation.

3. Determine which caster requires adjustment and the approximate amount of change required to level the fryer.
4. Position the side of the fryer on the shipping carton, exposing the bottom of the fryer (Figure 5).
5. Completely remove the bolts holding the caster mounting plate that requires leveling adjustment. Retain the bolts for later reassembly.

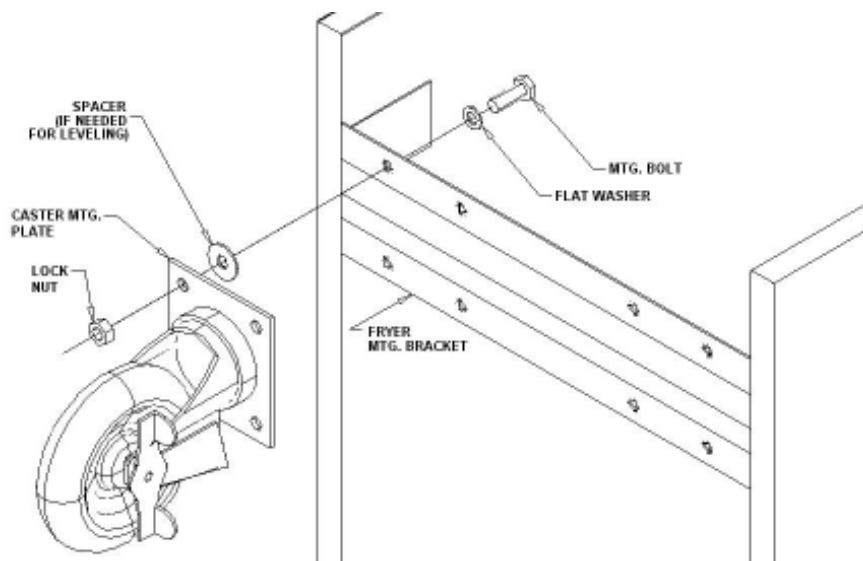

Figure 4. Typical Caster Installation

INSTALLATION REQUIREMENTS (Continued)

CASTER LEVELING INSTRUCTIONS (Continued)

6. Reinsert each mounting bolt through the caster mounting plate; next, place a spacer of the required size on the bolt before inserting the bolt into the bottom of the fryer.
7. Repeat step 6 for all remaining bolts.
8. Tighten all four bolts with locking nuts evenly and securely against the bottom of the fryer.
9. Return the fryer to its desired location. Lock the front casters to prevent fryer movement and check again for wobbling or rocking. Repeat steps 4 through 8 until no wobbling or rocking occurs. When the fryer no longer wobbles or rocks, perform step 10.
10. Next, perform the **“Fryer Restraining Device Installation Instructions.”**

GAS CONNECTION INSTRUCTIONS

Installing your *ANETS* Fryer requires the following procedure, after its legs or casters are properly attached and it is in its desired location.

1. Ensure that the gas safety valve control knob in the fryer has its OFF position next to the valvemark.
2. Ensure that the gas supply inlet line valve is closed (crosswise to the line direction).
3. Ensure that the fryer’s thermostat is set to OFF.
4. Connect the ½” gas supply line to the gas line adapter on the lower rear of the fryer.
5. Turn the gas supply line valve ON; then, check all gas supply line joints and couplings for leaks using soap suds or a leak-check solution, after the fryer is in its desired location.
6. Refer to **Fryer Operation Recommendations** and **Fryer Operating Instructions** to begin using your *ANETS* Fryer.



WARNING

DO NOT use a flame to check for leaks.

FRYER OPERATION RECOMMENDATIONS

 **CAUTION**

DO NOT attempt to operate this fryer during an interruption of gas service. Turn all fryer controls to OFF, including the gas control valve knob, then close the gas supply line valve. When notified that the interruption of gas service has ended, perform the Lighting Procedure (later in this manual).

 **DANGER**

NEVER operate this fryer when its flue is blocked because the combustion products can cause injury to personnel.

Please observe the following recommendations to obtain the optimum results from your *ANETS* Fryer.

 **DANGER**

Avoid moving the fryer while it contains HOT shortening. Drain the shortening from the fryer before moving it for service, cleaning or maintenance to avoid spilling or splashing. Burns from hot shortening can cause serious injury or death.

- A. An *ANETS* Model SLG40 Fryer is designed for operation with a kettle filled with approximately 35 to 40 pounds of liquid shortening. (This is approximately 3½ to 5 gallons.)

 **CAUTION: DO NOT** melt solid shortening in this fryer because the melting can damage the kettle, which will void the fryer warranty.

Shortening must be melted into the liquid state **before** it can be used in an *ANETS* Fryer.

- B. Schedule regular cleaning of the fryer to ensure long-term satisfactory operation. Refer to the **Daily Cleaning Procedure**, later in this manual.
- C. Before servicing and maintenance, allow the fryer to cool. **ALWAYS** shut off gas to the fryer while working on it, to prevent burns.
- D. Contact the factory (800-837-2638) for warranty service authorization. [**Always notify the factory the next business day about ‘after-hours’ warranty service.**] Contact your local restaurant equipment service agency for other service, repairs, or maintenance activities, as necessary.

FRYER OPERATING INSTRUCTIONS

Normal operation of an **ANETS** Fryer requires that the kettle is filled with liquid shortening to above the lower indent level marked on the rear of the kettle, before lighting the fryer's main burners.

CAUTION: Shortening **MUST** be in liquid form to avoid scorching or discoloration and possible damage to the kettle. Damage caused by melting solid shortening will **NOT** be covered by the warranty.

FRYER PREPARATION FOR USE "BOIL OUT" INSTRUCTIONS

Before using the newly installed fryer for food preparation, clean the rust preventive material from the kettle:

1. Thoroughly wipe the interior of the kettle with clean cloths. Open the front door on the lower portion of the fryer to access the drain ball valve. Open the drain ball valve (by aligning the valve handle with the drain ball valve) and wipe the entire drain line clear of rust preventive material.
2. Close the drain ball valve (turn the valve handle cross-wise to the drain ball valve). Fill the kettle with water to about 3" from the top. Add 1 to 2 cups of low sudsing soap powder, washing soda (trisodium phosphate), or deep fat fryer kettle cleaner.
3. Perform the **Lighting Procedure** for the fryer. (Refer to the **Lighting Procedure** later in this manual.)
4. Set the thermostat to 190°F. Heat, but **DO NOT** boil the water. Stir the water to dissolve the cleaning material.
5. Clean the fryer kettle for at least 20 minutes. Use a small hand mop (an optional brush can be ordered for this purpose) to clean the upper portion of the kettle (above the 3" waterline) and the top rim of the kettle.
6. Shut down the fryer using the **Shutdown Procedure** for the fryer. Refer to the **Shutdown Procedure** later in this manual. Allow the water to cool slightly.
7. Open the front door and mount the drain extension to the drain ball valve. Position a

FRYER PREPARATION FOR USE (Continued)

container (bucket) capable of holding **VERY HOT** cleaning solution beneath the end of the drain extension to hold the cleaning solution being drained, as shown in Figure 5.

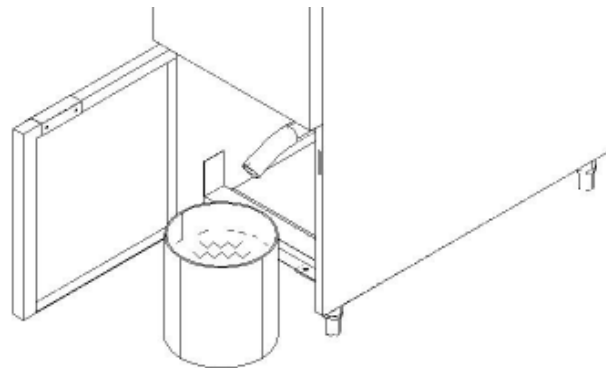

Figure 5. Draining The Kettle

8. Open the drain ball valve **SLOWLY**, to avoid splashes while draining the cleaning solution from the kettle.
9. Close the drain ball valve (valve handle *cross-wise*) and remove the drain extension. Close the front door.
10. Safely dispose of the cleaning solution.
11. Fill the kettle with water to about 3" from the top. Add 2 cups of vinegar to neutralize the cleaning solution.
12. Repeat steps 3 through 10 of this procedure.
13. Thoroughly wipe the interior of the kettle and the drain ball valve with clean, dry, wiping cloths to remove **ALL** water.
14. Dry the kettle thoroughly because any remaining water can cause spattering of hot shortening when the kettle is later filled and heated.

FRYER OPERATING INSTRUCTIONS (Continued)

LIGHTING PROCEDURE

NOTE: The gas line of a new fryer installation may contain a considerable amount of air which will hinder immediate lighting. You may have to press in the control knob as long as several minutes before the pilot flame burns steadily.

1. Open the front door and ensure that the fryer's thermostat knob is set to OFF.
2. Open the gas supply line inlet valve to the fryer by aligning the gas valve handle with the gas line piping.
3. Turn the gas control valve knob to align the PILOT setting with the valve mark. Figure 6 shows the possible control knob positions.
4. Press, and *hold down*, the valve control knob to allow pilot gas to flow. Apply a lighted

match to the end of the pilot burner, until the pilot flame lights.

NOTE: A butane lighter may also be used to light the pilot flame.

Continue holding down the control knob for *at least* 30 seconds until the pilot flame burns steadily, without going out.

5. Release the control knob and observe that the pilot flame remains lighted.
6. Turn the gas control valve knob to align the ON setting with the valve mark.
7. Turn the thermostat knob to the desired temperature. Observe that the fryer's main burners light to heat the kettle.

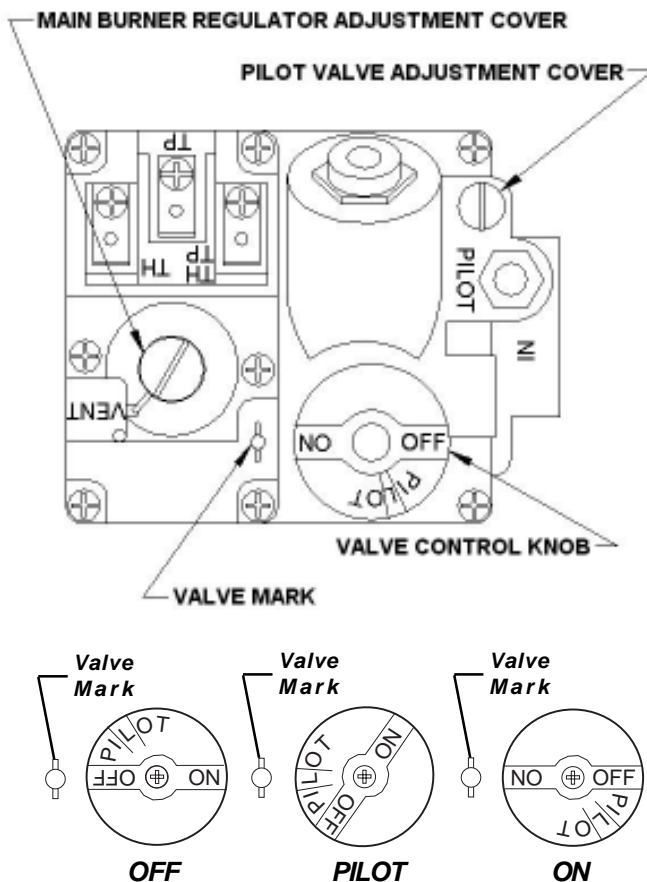

Figure 6. Gas Control Valve & Knob Positions

SHUTDOWN PROCEDURE

NOTE: Shutdown is *recommended* at the end of a workday or whenever no frying is scheduled for a period of several hours. To prevent damage, the fryer **MUST** also be shutdown whenever there is no shortening in the kettle.

1. Turn the thermostat knob to OFF.
2. Turn the gas control valve knob to align the PILOT setting with the valve mark. Observe that the main burners' flames go out.
3. Press *down* and turn the gas control valve knob to align the OFF setting with the valve mark. Observe that the pilot flame goes out.

NOTE: For extended periods of non-use *or* when servicing the fryer, close the gas supply line inlet valve to the fryer by turning the gas valve handle cross-wise with the gas line piping.

FRYER OPERATING INSTRUCTIONS (Continued)

RECOMMENDED FRYING TIME FOR POPULAR FRIED FOODS

Load the fryer basket with the food product while the basket is **not** in the hot liquid shortening. **DO NOT** overload the fryer basket. Load only a premeasured quantity of food product (**1½ lb**, typically; less, if smaller portions are desired). Place the loaded fryer basket into the hot liquid shortening carefully to avoid splashing.

When the basket of food product has reached the desired point of 'doneness', lift the basket from the hot shortening and hang the basket on the basket hanger to let it drain for approximately 15 - 30 seconds before serving.

NEVER increase the thermostat setting above the recommended setting to reduce the cooking time; this will produce a lower quality product and will cause more rapid shortening breakdown.

Food Product	ANETS Fryer (° F)	Frying Time (minutes)
Breaded Foods	340	
Cheese Sticks		3
Mushrooms		2½ - 3
Onion Rings		2½ - 3
French Fries (Typical 1½ lb Load)		
Raw to Done 1/4" cut		5
Blanched, only 1/4" cut		2½
Browned, only 1/4" cut		2½
Raw to Done 3/8" cut		6
Blanched, only 3/8" cut		3
Browned, only 3/8" cut		3
Raw to Done 1/2" cut		7
Blanched, only 1/2" cut		4
Browned, only 1/2" cut		3
Frozen Fish (Fillets or Sticks)	4 - 7	
Tortilla Chips*	340	2 - 2½

* - Use a second basket on top of the chips in the bottom basket, to keep them within the hot shortening; otherwise, they float before cooking completely.

FRYER OPERATING INSTRUCTIONS (Continued)

DAILY CLEANING PROCEDURE

NOTE: Cleaning is *recommended* at the end of a workday to prepare the fryer for proper operation the next time it is to be used.

DANGER

Avoid moving the fryer while it contains HOT shortening. Drain the shortening from the fryer before moving it for service, cleaning or maintenance to avoid spilling or splashing. [Refer to steps 1 through 7.] Burns from HOT shortening can cause serious injury or death.

1. Open the front door of the fryer. Attach the drain extension to the drain ball valve.
2. Perform the **Shutdown Procedure**. Ensure that the gas supply line inlet valve is closed (handle cross-wise to pipe line) and the pilot flame is extinguished.
3. Position a steel drum [NEVER use plastic!] with a filter cone directly beneath the drain extension end.
4. Slowly open the drain ball valve to drain the HOT shortening.
5. Remove the fryer baskets and screen from the kettle. Remove the basket hanger from the flue. Clean, and rinse, these items in the sink. **MAKE SURE** that these items are completely dry before their next use.
6. Clear any sediment blocking the kettle drain. Flush out all sediment in the bottom of the kettle by pouring filtered liquid shortening into the kettle until the shortening being drained runs clear.
7. Close the drain ball valve, after the kettle is completely empty of shortening and sediment. Detach the drain extension. Clean, rinse, and dry it before storing.

DAILY CLEANING PROCEDURE (Continued)

WARNING

Wait until the kettle has cooled before performing step 8, to avoid injury from burns.

8. Thoroughly wipe the kettle interior using clean cloths.
9. Periodically perform the **“BOIL OUT” Instructions** to ensure thorough cleaning of the kettle. (Refer to the earlier FRYER PREPARATION FOR USE section.)
10. Return the fryer to its normal operating location, if it was moved for cleaning, and reconnect both the gas supply line and the movement-limiting cable. (For caster-equipped fryers, lock the locking casters to prevent movement.)
11. Refill the kettle with filtered (or fresh) liquid shortening to the desired indent mark on the rear wall of the kettle, *only* if fryer operation is to continue during a subsequent shift. Otherwise, melt shortening into its liquid state and refill the kettle before fryer operation is scheduled during the next normal working shift.
12. Attach the basket hanger to the top of the backsplash panel. Return the screen and fryer baskets to their proper positions on the basket hanger.
13. Perform the **Lighting Procedure** to return the fryer to operation, when desired.

FRYER OPERATING INSTRUCTIONS (Continued)

MONTHLY MAINTENANCE INSTRUCTIONS

NOTE: Regular maintenance is *recommended* to keep the fryer operating properly.

Once each month, before beginning fryer operation, check the flue (behind the backsplash panel) to ensure that it is clear and free of obstructions, enabling exhaust combustion gases to flow freely toward the ventilation hood area. **DO NOT** allow the flue to become excessively dirty.

Monthly, observe the condition of the ventilation hood. If it shows evidence of a great deal of greasy residue, remove (clean) the residue to allow free flow of ventilation air.

FRYER TROUBLESHOOTING GUIDE

All service (repairs or part replacement) must be performed by a qualified Service Agency.

<i>PROBLEM</i>	<i>CAUSE</i>	<i>REMEDY</i>
<p>Pilot flame does not stay lighted.</p>	<ol style="list-style-type: none"> 1. Dirty/sooty pilot burner. 2. Low gas supply pressure [less than 6" W.C. for natural gas (11" W.C. for propane) when all other gas-powered equipment is operating.]. 3. Pilot flame too small to heat thermo pile. 4. Pilot flame 'wavering' (being blown about by a draft). 5. Improper thermopile output voltage (must be at least 180 millivolts, measured at the thermocouple junction block). 6. High-limit thermostat problem has shut off the gas. 	<ol style="list-style-type: none"> 1. Clean the pilot burner. Perform the Lighting Procedure. 2. Measure the gas supply pressure. Contact your local gas supplier to obtain adequate gas supply volume and pressure. 3. Adjust the pilot valve (part of the gas safety valve) to increase the flame size: Unscrew and retain the large threaded cover; turn the pilot valve adjustment screw <i>two turns</i> counterclockwise; reinstall the threaded cover. 4. Block or redirect the draft, to keep the flame burning steadily. 5. Replace the thermopile. 6. Check for, and repair, any damaged high-limit thermostat wiring. Otherwise, test the high-limit thermostat by bypassing the high-limit thermostat (black and blue wires) at the gas control valve with a jumper wire. Next, perform the Lighting Procedure, to check whether the pilot flame lights. If the pilot flame lights and stays lit, the high-limit thermostat has failed and must be replaced.
	<ol style="list-style-type: none"> 7. Gas control valve has failed. 	<ol style="list-style-type: none"> 7. Replace the gas control valve.

CAUTION: DO NOT return the fryer to normal operation with its high-limit thermostat bypassed.

FRYER TROUBLESHOOTING GUIDE (Continued)

<i>PROBLEM</i>	<i>CAUSE</i>	<i>REMEDY</i>
<p>Pilot flame goes out repeatedly.</p>	<ol style="list-style-type: none"> 1. Low gas supply pressure [less than 6" W.C. for natural gas (11" W.C. for propane) when all other gas-powered equipment is operating.]. 2. Loose thermocouple or high-limit thermostat connection(s) on gas control valve. 3. Pilot flame does not continuously touch the thermocouple because of excessive air flow around the pilot burner assembly. 4. High-limit thermostat problem has shut off the gas. 	<ol style="list-style-type: none"> 1. Measure the gas supply pressure. Contact your local gas supplier to obtain adequate gas supply volume and pressure. 2. Check and tighten the connections. 3. Block the excessive air flow to make the pilot flame contact the thermocouple. 4. Check for, and repair, any damaged high-limit thermostat wiring. Otherwise, test the high-limit thermostat by bypassing the high-limit thermostat (black and blue wires) at the gas control valve with a jumper wire. Next, perform the Lighting Procedure, to check whether the pilot flame lights. If the pilot flame lights and stays lit, the high-limit thermostat has failed and must be replaced.
 CAUTION: DO NOT return the fryer to normal operation with its high-limit thermostat bypassed.		
<p>Main burners do not ignite.</p>	<ol style="list-style-type: none"> 1. Gas control valve knob set to OFF or PILOT. 2. Low gas supply pressure [less than 6" W.C. for natural gas (11" W.C. for propane) when all other gas-powered equipment is operating.]. 3. Pilot burner problem. 4. Thermostat control set below the temperature of the liquid shortening in the kettle. 	<ol style="list-style-type: none"> 1. Perform the normal Lighting Procedure. Turn the gas control valve knob to ON to light the main burners. If the burners do not light, the gas safety valve has failed and must be replaced. 2. Measure the gas supply pressure. Contact your local gas supplier to obtain adequate gas supply volume and pressure. 3. Refer to the preceding Pilot Burner problems and use the correct remedy. 4. Increase the thermostat setting until the burners light. If this setting is greater than the desired temperature, reset the thermostat.

FRYER TROUBLESHOOTING GUIDE (Continued)

<i>PROBLEM</i>	<i>CAUSE</i>	<i>REMEDY</i>
Main burners do not ignite. (Continued)	5. Gas control valve has failed.	5. Replace the gas control valve.
Main burners do not stop burning.	1. Thermostat has failed. 2. Gas control valve has failed.	1. Turn the thermostat control knob to OFF. If the burners do not quit burning, the thermostat has failed and must be replaced. 2. Turn the gas control valve knob to OFF. If the burners do not quit burning, the gas control valve has failed and must be replaced.
Liquid shortening does not reach the desired temperature for frying.	1. Low gas supply pressure [less than 6" W.C. for natural gas (11" W.C. for propane) when all other gas-powered equipment is operating], causing reduced heat from main burners. 2. Low gas manifold pressure [less than 3½" W.C. for natural gas (10" W.C. for propane)]. 3. Loose knob on thermostat; or thermostat requires calibration (temperature setting differs by about 10°F from the measured shortening temperature).	1. Measure the gas supply pressure. Contact your local gas supplier to obtain adequate gas supply volume and pressure. 2. Measure the gas pressure at the fryer's manifold pressure tap. Adjust the manifold pressure (see Figure 6), as necessary: [a] Unscrew (and retain) the threaded Main Burner Regulator Adjustment Cover. [b] Use a flat-blade screwdriver to turn the regulator adjustment screw (clockwise to increase; counterclockwise to decrease) to reset the pressure adjustment. [c] Reinstall, and tighten the Regulator Adjustment Cover, when finished. 3. Stir the shortening to mix the hot shortening with some from the lower 'cool zone' and allow it to sit for 5 minutes. Turn the thermostat knob until it 'clicks' <i>on</i> (causing the main burners to flame); note the setting where this occurs. Turn the thermostat knob until it 'clicks' <i>off</i> (causing the main burners to go out); note the setting where this occurs. Repeat this tempera-

FRYER TROUBLESHOOTING GUIDE (Continued)

<i>PROBLEM</i>	<i>CAUSE</i>	<i>REMEDY</i>
<p>Liquid shortening does not reach the desired temperature for frying. (Continued)</p>	<p>3. Loose knob on thermostat; or thermostat requires calibration (temperature setting differs by about 10°F from the measured shortening temperature). (Continued)</p>	<p>3. (Continued) ture ‘click points’ step at least three times to ensure that the shortening temperature has stabilized. Measure the temperature of the shortening by inserting an <i>accurate</i> thermometer about 4 inches into the shortening to measure its temperature. If the temperature difference between the measured temperature and the thermostat setting is more than 15°F the thermostat is failing and must be replaced.</p>

NOTE: A Parts List for each ANETS Fryer is among the items shipped with each fryer. If an additional copy of this list is needed, please contact the factory as directed on the back cover.

LIMITED WARRANTY

ANETSBERGER BROTHERS, INC., Northbrook, Illinois, USA, certifies that all equipment of its manufacture is, to the best of its knowledge, free from defective material and workmanship.

ANETSBERGER BROTHERS, INC., agrees to replace any integral part of its equipment that proves defective within 15 months of date of original shipment from the factory, or 12 months from the date of installation, whichever is sooner. Buyer must return the defective part to the factory, freight prepaid, for inspection. Anetsberger Brothers, Inc., further agrees to assume the cost of installing said replacement part within the same period.

All frypots are covered by the warranty above for the first year of operation. Various models have an extended warranty that covers the replacement of the frypot only. See the individual specification sheets for details.

Overtime charges, calibration, adjustments and abnormal installation charges shall not be at the expense of Anetsberger Brothers, Inc.

The conditions and warranty expressed above are valid only if equipment has been properly installed and operated. No other warranty, expressed or implied, shall govern equipment manufactured by Anetsberger Brothers, Inc. Under no circumstances shall Anetsberger Brothers, Inc., be liable for loss of profits or any direct or indirect cost, expenses, loss or damages arising out of defects in or failure of the equipment or any part thereof.



Anetsberger Brothers, Inc.

180 North Anets Drive • Northbrook, Illinois 60062 • 847-272-0770 • Fax 847-272-1943

Toll-free Customer & Warranty Service: 800/ 837-2638

www.anetsberger.com

Keep this Manual in a Convenient Location for Reference