



Champion Griddle Electric

Models: EG-24H EG-36H EG-48H

PRODUCT:

QUANTITY:

ITEM #:

Designed Smart

Increased Performance in Cooking

- Unique Heating system, incorporating special heating elements that transfer heat energy to griddle surface more efficiently than traditional models.
- Fast startup to cooking temperatures (reaches 350 degrees in 11 minutes).
- Provides fast recovery with heat levels reaching 450 degrees.

Safety Features

- New bull-nose front extension protects employees from burns.



Model EG-24H Electric Griddle

Built Solid

Built to Last!

- Thick, stainless steel construction on front panel and top skirt
- 3/4 inch polished steel griddle surface stands up to years of high output cooking.
- Griddle plate is fully welded to base.
- Welded construction in frame base.

Reliability backed by APW Wyott's Warranty

- APW Wyott cooking equipment is backed by a 3-year limited warranty, and a 1-year on-site labor warranty.

- Certified by the following agencies:



APW Wyott Design Features

- Stainless steel construction.
- 4" (10 cm) adjustable legs.
- 12" cooking section for zone control.
- 3/4" flat polished steel griddle plate.
- 3 3/16" spatula-width stainless steel front grease trough.
- 4" x 1" grease chute.
- 4 gallon grease collection drawer.
- 3" stainless steel backsplash.
- Sloped stainless steel side splash.
- Easy-to-read control knobs.

Options & Accessories

- Safety Pilot

See reverse side for product specifications.



APW Wyott Foodservice Equipment Company · 729 Third Ave., Dallas, TX 75226
(800) 527-2100 · (214) 421-7366 · Fax (214) 565-0976 · www.apwwyott.com · info@apwwyott.com

Rev. 6/02/2008

PRODUCT:

QUANTITY:

ITEM #:

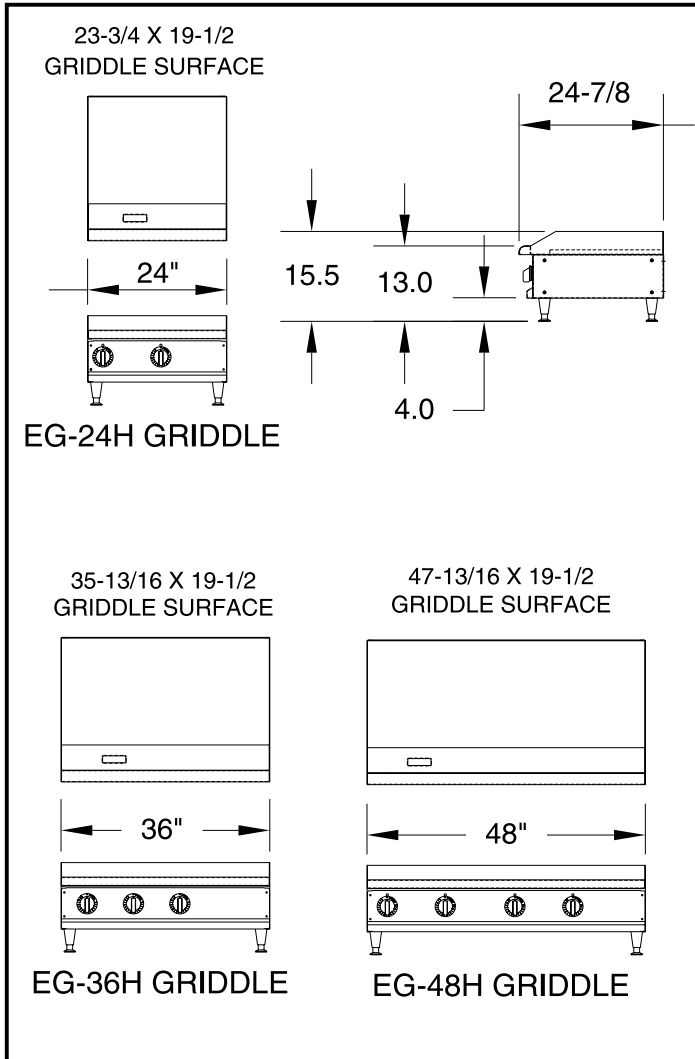

Countertop Electric Griddle

PRODUCT SPECIFICATIONS

Construction:

Heavy-duty stainless steel front and top skirt with aluminized steel sides and back. Welded construction. Cold rolled steel fire box. 3/4" polished steel griddle plate. 4" adjustable legs.

Electrical Specifications:

EG-24H: 208V, 6.75 KW, 32.5 Amps
230V, 8.2 KW, 35.9 Amps
240V, 9 KW, 37.5 Amps

EG-36H: 208V, 10 KW, 48.7 Amps
230V, 12.4 KW, 53.9 Amps
240V, 13.5 KW, 56.3 Amps

EG-48H: 208V, 13.5 KW, 65 Amps
230V, 16.5 KW, 71.9 Amps
240V, 18 KW, 75 Amps

Terminal block located on right side of unit.

Overall Dimensions:

EG-24H: 15 1/2" H x 24" W x 24 7/8" D
(39.2 cm x 61 cm x 62.4 cm)

EG-36H: 15 1/2" H x 36" W x 24 7/8" D
(39.2 cm x 91.4 cm x 62.4 cm)

EG-48H: 15 1/2" H x 48" W x 24 7/8" D
(39.2 cm x 122 cm x 62.4 cm)

Shipping:

EG-24H: 180 lbs. (81.8 kg)
EG-36H: 252 lbs. (114.5 kg)
EG-48H: 342 lbs. (155.4 kg)

Freight Class: 100
FOB: Cheyenne, WY

*APW Wyott reserves the right to modify specifications or discontinue models without incurring obligation.