



729 Third Avenue
Dallas, TX 75226

Phone: (214) 421-7366
 Fax: (214) 565-0976
 Toll Free: (800) 527-2100
 Website: www.apwwyott.com
 E-mail: info@apwwyott.com

INSTALLATION INSTRUCTIONS COLD HOT DUAL TEMPERATURE WELL

Model Numbers: CHDT-2, -3, -4, -5 & -6



(Model CHDT-4 Shown)

MINIMUM CLEARANCE REQUIRED FROM UNIT TO THE NEAREST SURFACE			
Back	Side	Bottom	Front
0" (0 mm)	0" (0 mm)	N/A	3" (76 mm)

DIMENSIONS

MODEL	A		B		C (CUTOUT)	
	INCHES	MM	INCHES	MM	INCHES	MM
CHDT-2	32 3/4	832	25 1/2	648	31 1/2	800
CHDT-3	46 1/2	1181	39 1/4	997	45 1/4	1149
CHDT-4	60 1/4	1530	53	1346	59	1499
CHDT-5	74	1880	66 3/4	1695	72 3/4	1848
CHDT-6	87 3/4	2229	80 1/2	2045	86 1/2	2197



MEETS NSF STANDARD 7
PERFORMANCE REQUIREMENTS
AT 3" PAN RAIL DEPTH

ELECTRICAL

MODEL	WARMER				REFRIGERATION				SINGLE PHASE SUPPLY 3 WIRE 120/208-240V L1-L2 208-240V L2-N 120VAC 60 HZ	
	VOLTS	KW	AMPS (1 PHASE)		VOLTS	HP	AMPS (1 PHASE)			REFRIGERANT TYPE
			L1 - L2	N			L2 - N	L1		
CHDT-2	208	1.9	9.0	N.A.	120	1/4	5.5	N/A	R-134-A	
	240	2.5	10.4	N.A.						
CHDT-3	208	3.0	14.4	N.A.	120	1/3	7.0	N/A	R-404-A	
	240	4.0	16.7	N.A.						
CHDT-4	208	3.8	18.1	N.A.	120	1/2	7.5	N/A	R-404-A	
	240	5.0	20.8	N.A.						
CHDT-5	208	6.0	28.9	N.A.	120	3/4	15.3	N/A	R-404-A	
	240	8.0	33.3	N.A.						
CHDT-6	208	6.0	28.9	N.A.	120	3/4	15.3	N/A	R-404-A	
	240	8.0	33.3	N.A.						

**ALL MODELS
PERMANENTLY
CONNECTED**

MODEL CHDT-3 SHOWN

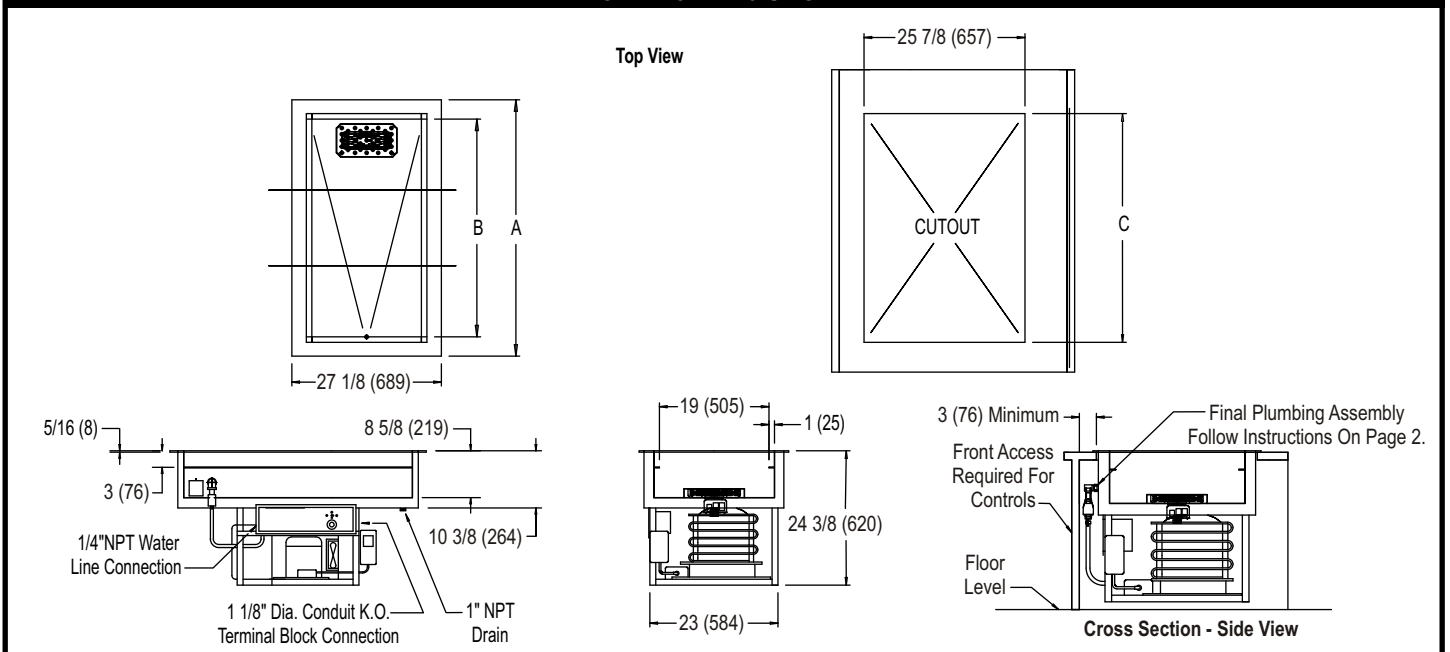

INSTALLATION INSTRUCTIONS: COLD HOT DUAL TEMPERATURE WELL (Models CHDT-2 Thru CHDT-6)

INSTALLER MUST MEET CONDITIONS OF ACCEPTABILITY OUTLINED BELOW UPON INSTALLATION:

1. This unit may be installed in stainless steel, wood, Formica, or Corian tables and countertops.
2. This unit requires drain connection. It also requires a 120/208-240 volt single phase power supply connection.
3. When installing the unit it is essential to provide front access for service and temperature adjustment. It should have openings to allow for proper air circulation. Opening shall be at least twice the surface area of the condenser. Improper ventilation will cause compressor burnout and void the warranty.

TO FABRICATE:

1. Lay out 'cutout' dimensions on countertop or table.
2. Cut out hole. Make certain countertop is flat and level side to side and front to back before installing the unit.
3. Provide support from below to reduce load on countertop. For remote control panel mounting see below.

TO INSTALL:

1. Apply a generous bead of silicone sealant to underside of mounting flange before setting unit into cutout. Remove excess sealant from top flange and countertop.
2. Remove thermostat knob and recessed control panel from control box for access to terminal block.

FOR PLUMBING AND WIRING PLEASE REFER TO THE BOTTOM OF THIS PAGE

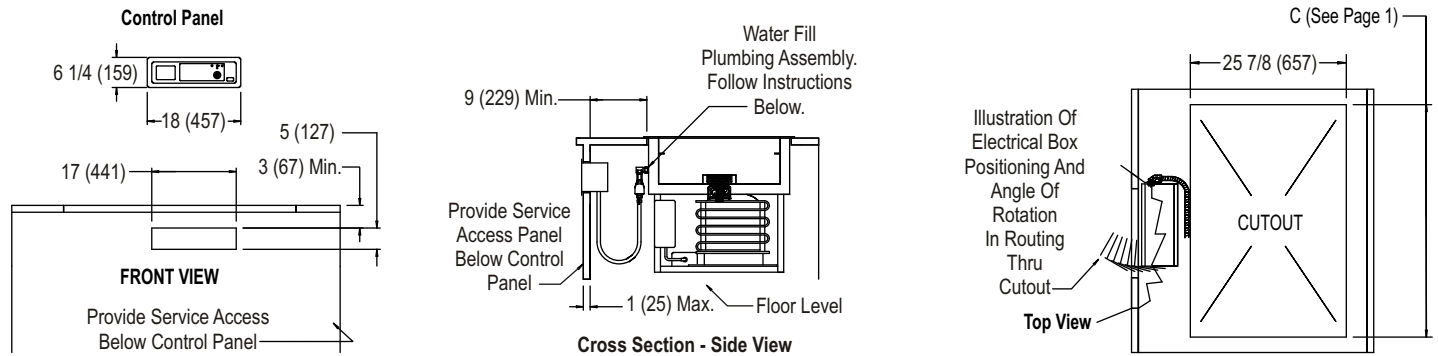

REMOTE CONTROL PANEL INSTALLATION INSTRUCTIONS

TO FABRICATE:

1. Lay out "cutout" dimensions on countertop or table.
2. Lay out control panel cutout in the front apron. **Note:** Control panel assembly is provided with extra length of flexible conduit and electric wiring. This option allows for installation of the controls outside the enclosure for easy access. Provide louvered grills service access and temperature adjustment to the refrigeration system.

TO INSTALL:

1. Apply a generous bead of silicone sealant to underside of mounting flange before setting unit into cutout.
2. Lower the unit into the counter cutout. Wipe clean excess sealant.
3. Remove thermostat knob and recessed control panel from control box.
4. Remove control box assembly from framework. Release wiring conduit from wire ties and retainers.
5. Install control box (Refer to Top View) by routing it thru the cutout.
6. Fasten control box by using six (6) screws provided.

PLUMBING AND WIRING INSTRUCTIONS

TO PLUMB:

Note: Plumbing connections must be completed after the unit is lowered onto the counter cutout. The water fill hose with check valve assembly is shipped disconnected from the tank for ease of setting unit into the cutout at installation.

1. Apply pipe sealant to the water fill tank fitting and attach the pre-assembled check valve assembly.
2. Attach water fill hose to hose fitting with hose clamp.
3. Connect 1/4NPT water supply and shut off valve to solenoid valve in control box. **Note:** Maximum pressure 120 psi. Maximum temperature 120°F.
4. A drain valve is supplied with the unit. It is the discretion of the installer to locate the position of the handle. Connect 1 inch drain to drain pan or floor drain. Valve access must be provided for draining pan.

TO WIRE:

Note: MAKE CERTAIN POWER SUPPLY LINE IS DE-ENERGIZED BEFORE WIRING APPLIANCE.

Unit operates on 120/208-240 volt single phase system. Use #8AWG minimum 60°C supply leads only. Make certain that 'L1 to L2' reads 208 to 240 VAC and 'L2 to N' reads 120 VAC. Bring supply leads through 1 1/8" conduit K.O. to terminal block pre-installed in the electrical box.

Install control panel and control knob.

Note: INSTALLATION MUST MEET LOCAL PLUMBING AND ELECTRICAL CODES

A backflow preventer check valve is incorporated in unit between water fill solenoid and pan. Local codes may require additional vacuum break device.