



DANTE
SERIES

**HIGH PERFORMANCE
COUNTERTOP
RADIANT
CHAR BROILERS**



Model XXE-4
with optional stainless steel splash guard

SPECIFICATIONS

High performance Countertop gas radiant char broiler with low profile design is only 15 7/8" (403mm) to broiling surface making the XXE broiler ideal for use on refrigerated cabinets while a 24" deep broiling surface provides the largest broiling area and production capacity in its class.

Exterior is all stainless steel with unique air blanket for ventilation and cooler outer temperatures. Front grease trough, slide out stainless steel water pan/grease drawer and 4" (102mm) chrome plated adjustable legs are standard. Interior combustion chamber is fabricated of 11 gauge HRS and hand welded to form a single unitized body.

The XXE models feature 24" long, extra high performance 20,000 BTU/HR, independently controlled center feed clog-proof, high efficiency burners located every 4 7/8" (124mm) for maximum heat. Flame failure safety pilots are standard.

14 Gauge, 300-series stainless steel radiant heat deflectors are placed directly above each burner for even heat transfer to the broiling surface, while cast iron radiants are optional. Additional stainless steel heat deflectors are located between each burner for higher temperatures and uniform heat.

Standard top grates are cast iron with channels to direct grease to front trough. Grates are 24" (610mm) long with 3/4" (19mm) rib spacing, while several grate types are optional and may be mixed and matched.

Each grate may be manually adjusted in any of three separate tilting positions.

Job _____ Item # _____

GAS CHAR BROILERS



- Model XXE-4
- Model XXE-6
- Model XXE-8
- Model XXE-10
- Model XXE-12

STANDARD FEATURES

- 20,000 BTU/HR clog-proof, center-feed burners with individually operator controlled valves located every 4 7/8"
- Up to 240,000 BTU/HR total per broiler
- Natural or propane gas (CE not available in LP)
- Flame failure safety pilots
- Adjustable cast iron top grates - floating rod grates or meat grates available no charge
- All stainless steel exterior finish
- Stainless steel slide out grease drawer/water pan and 4" legs
- Stainless steel radiant heat deflectors above each burner
- Additional stainless steel heat deflectors located between each burner
- 3/4" (19mm) NPT rear gas connections and pressure regulators
- Heavy plate steel unitized body construction
- Limited one year parts & labor warranty

OPTIONS & ACCESSORIES

- Stainless steel front-mounted work deck with or without sauce pan cut-outs
- Condiment Rail
- Richlite front mounted work deck with or without sauce pan cut-outs
- Cast iron radiants
- Stainless steel equipment stand with or without casters
- Meat grates, fish grates, floating rod grates and/or fajita grates
- Gas connector hoses
- Stainless steel splash guards
- Removable griddle plates
- Overhead back shelves
- Grate lifters

CERTIFICATIONS



BAKERS PRIDE OVEN COMPANY, INC.
30 Pine Street, New Rochelle, NY 10801
914/576-0200 • 1-800-431-2745 • fax 914/576-0605
www.bakerspride.com

Continuous product improvement is a policy of Bakers Pride Oven Company. Therefore, specifications and design are subject to change without notification

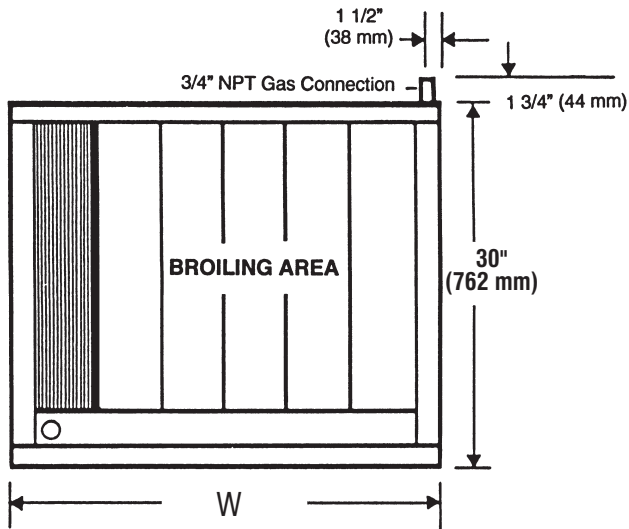

TOP VIEW

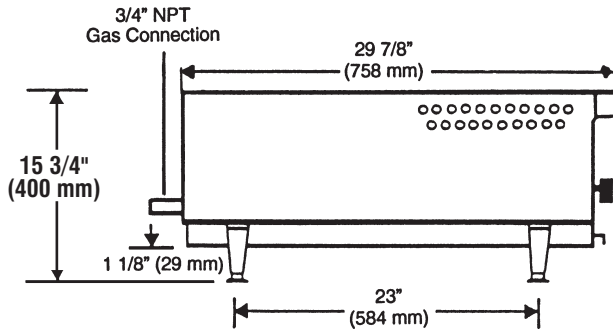

FRONT VIEW

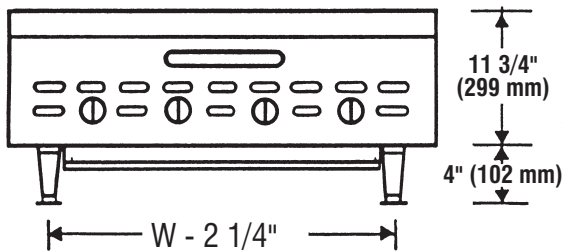

FRONT VIEW

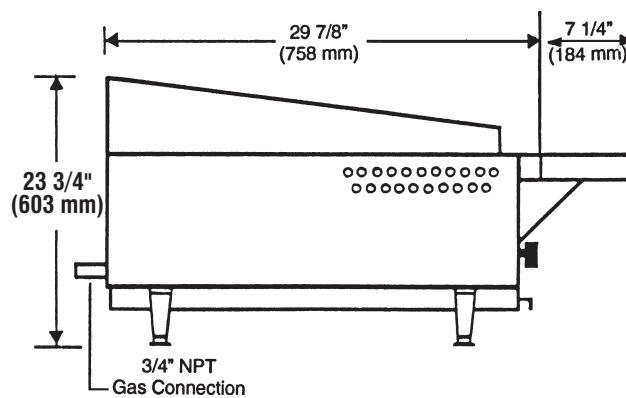

**SIDE VIEW
with S/S SPLASH GUARD
and WORK DECK OPTIONS**

ALL DIMENSIONS NOMINAL

Model	Shipping Weight		Carton Dimensions					
	Lbs.	Kilos	Width		Depth		Height	
			Inches	mm	Inches	mm	Inches	mm
XXE-4	378	171	32	813	36	914	28	711
XXE-6	496	225	34	867	52	1321	28	711
XXE-8	608	276	34	867	52	1321	28	711
XXE-10	800	363	34	867	64	1626	28	711
XXE-12	900	409	74	1863	36	914	34	867

GAS SUPPLY			
Model	BTUH	KW	CONNECTION
XXE-4	80,000	23.44	3/4"
XXE-6	120,000	35.16	3/4"
XXE-8	160,000	46.88	3/4"
XXE-10	200,000	58.60	3/4"
XXE-12	240,000	70.32	3/4"

Model	Broiling Area		# Top Grates	# of Burners	Overall Dimensions*					
					Width		Depth		Height	
	in.	mm			Inches	mm	Inches	mm	Inches	mm
XXE-4	21 x 24	533 x 610	4	4	26 1/4	667	30	762	15 3/4	400
XXE-6	31 1/2 x 24	800 x 610	6	6	36 3/4	933	30	762	15 3/4	400
XXE-8	42 x 24	1067 x 610	8	8	47 3/4	1213	30	762	15 3/4	400
XXE-10	52 1/2 x 24	1334 x 610	10	10	58 1/4	1480	30	762	15 3/4	400
XXE-12	63 x 24	1500 x 610	12	12	68	1727	30	762	15 3/4	400

*Height includes 4" (102 mm) optional legs

MINIMUM CLEARANCES		
	Inches	mm
Right	0	0
Left	0	0
Rear	0	0

• From non-combustible construction
• Install only with non-combustible material above grate level



BAKERS PRIDE OVEN COMPANY, INC.
30 Pine Street, New Rochelle, NY 10801
914/576-0200 • 1-800-431-2745 • fax 914/576-0605
www.bakerspride.com

Continuous product improvement is a policy of Bakers Pride Oven Company. Therefore, specifications and design are subject to change without notification

COOKLINE-XXE Series — TSW:06/08