



# BEVERAGE-AIR

3779 Champion Blvd., Winston-Salem, NC 27105  
1-888-845-9800 Fax# 1-336-245-6453  
<http://www.Beverage-Air.com>

Item No. \_\_\_\_\_  
Quantity \_\_\_\_\_

## SCHOOL MILK COOLERS SM SERIES

MODELS:  
SM34N  
SM49N  
SM58N

### Commercial Refrigeration Equipment General Specification

#### SM SERIES—SINGLE ACCESS, COLD WALL

Single access, cold wall milk coolers are designed to hold milk between 36°F and 38°F until ready to serve. Produced in three sizes to hold 8, 12, and 16 milk cases ( 13" x 13" x 11" ) per unit.

#### CABINET CONSTRUCTION

Standard SM models include lids, doors, adjustable hinges, and door latches made from stainless steel. Balance of exterior is white finish on steel. One-piece, reinforced stainless steel floor for maximum milk crate support. Balance of interior is galvanized steel. Heavy-duty, epoxy coated steel wire floor racks are provided for added floor protection. Floor drain is centrally located for easy cleaning, connecting to drain hose with hose adapter.

Exterior thermometer, cylinder lock, bottom drain, and 4" swivel casters (2 with locks) are provided as standard.

Foamed-in-place CFC and HCFC-free polyurethane insulation enhances the structural strength of the cabinet and helps increase energy efficiency. This insulation helps to prevent liquid penetration that results in foul odors. Overall depth of 31" allows easy mobility and clear passage through most doorways.

Models are also offered with stainless steel exterior in place of white finish on steel. A stainless steel interior is optionally available. Additional options include wrap around and corner bumpers.

#### REFRIGERATION

Refrigeration system uses R404A refrigerant, which is CFC and HCFC-free for compliance with environmental safety concerns.

#### ELECTRICAL

Units wired at factory and ready for connection to a 115/60/1 phase, 15 amp dedicated outlet. 8' long cord and plug set included.

#### SPECIAL FEATURES

- One-piece, reinforced stainless steel floor for maximum support of milk crates.
- SM models have earned the ENERGY STAR®.
- Stainless options available.



Available From:

\*Note: Not all markings may apply to all model variations.

<b>Model Specified</b> _____	<b>Store#</b> _____
<b>Location</b> _____	<b>Quantity</b> _____



**BEVERAGE-AIR**

**SM SERIES School Milk Coolers**

Models: SM34N, SM49N, SM58N

MODEL	SM34N	SM49N	SM58N
<b>EXTERNAL DIMENSIONAL DATA</b>			
Length Overall (inches)	34 1/2"	49 1/2"	58 1/2"
Length Overall (mm)	876	1257	1486
Depth Overall (inches)	31"	31"	31"
Depth Overall (mm)	787	787	787
Height Overall— (inches)	39 1/2"	39 1/2"	39 1/2"
Height Overall—(mm)	1003	1003	1003
Number of doors/lids	Single/Access	Single/Access	Single/Access
<b>INTERNAL DIMENSIONAL DATA</b>			
NET Capacity (cubic ft.)	13.6	20	24
NET Capacity (Liters)	385	566	679
<b>CASE CAPACITIES</b>			
13" x 13" x 11"	8	12	16
19" x 13" x 11"	4	8	10
<b>ELECTRICAL DATA</b>			
Full Load Amperes 115/60/1	4	7.5	7.5
<b>ENERGY CONSUMPTION (KWH)</b>			
	2	1.8	2.25
<b>REFRIGERATION DATA</b>			
Horsepower	1/4	1/4	1/3
<b>WEIGHT DATA</b>			
Gross Weight (Crated lbs)	277	339	376
Gross Weight (Crated kg)	126	154	171

**PLAN VIEWS**

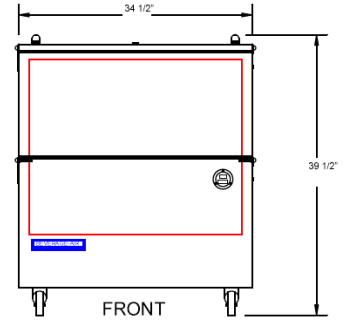

**SM34N**

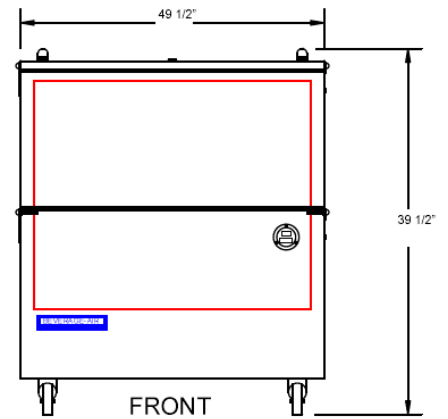

**SM49N**

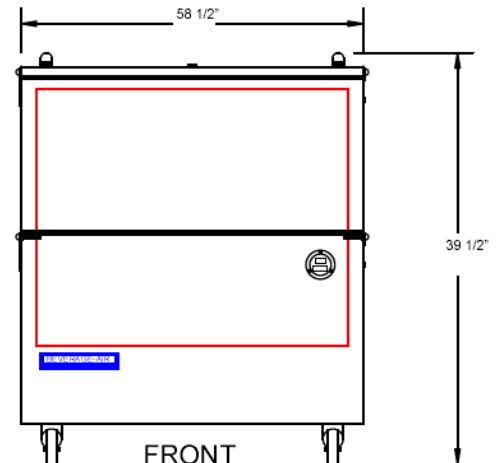

**SM58N**

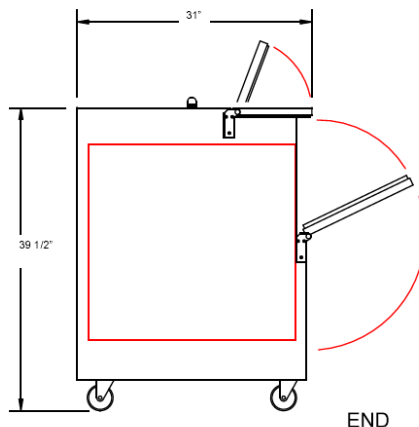

**END**



\*Note: Not all markings may apply to all model variations.

**ELECTRICAL CONNECTION**

Units pre-wired at factory and include 8' long cord and plug set.



**BEVERAGE-AIR® CORPORATION**

3779 Champion Blvd. • Winston-Salem, NC 27105 USA • (336) 245-6400 • Fax (336) 245-6453 • (888) 845-9800 • www.beverage-air.com

Specifications are subject to change without prior notice. 08/10