



50 lbs. 23kg to 60 lbs. 27kg Capacity

POTATO and VEGETABLE

# PEELER

MODEL

## XC-60 & XC-60T

### BLAKESLEE



DISCHARGE CAN BE DIRECTLY INTO A SINK.

A "T" IN MODEL NO. INDICATES "TIMER" INCLUDED WITH MODEL XC-60T.

#### CAPACITY

50 lbs. 23 kg to 60 lbs. 27 kg, 1 to 3 minutes. One peeling cycle will serve 180 to 200 persons when potatoes are mashed in a Blakeslee Food Mixer.

#### CONSTRUCTION

Entire machine is constructed of stainless steel. Discharge chute and hinged door are of rust-free, easy to clean aluminum. Removable cover is light weight, easy to clean, molded polystyrene. Motor and drive unit are "sealed off" against moisture to assure trouble-free performance. Entire peeling chamber can be adjusted to any position to insure both the peel trap strainer basket and discharge chute are in the proper position for ease of operation. This can be done without use of any special tools by easily lifting and turning the special peeling chamber.

#### DISCHARGE CHUTE

Discharge chute is rust-free, easy to clean aluminum. The hinged aluminum door is not furnished with a gasket so fingertip ease is all that is required to open and close door. A trough is furnished in the discharge chute to catch seepage returning it to the machine. The combination of the trough and the door without a gasket eliminates any future problem of a gasket wearing out and water seeping past the door. Door is light-weight and is self-closing when released from the open position. Discharge chute in 37" 940 mm to 39½" 1050 mm from floor based on adjustment of feet (discharge can be directly into sink).

#### MOTOR

1 H.P., grease-packed, ball bearing, ventilated motor. Available for operation of 115/230 volt, 60 cycle, 1 phase or 208/220 volt, 60 cycle, 3 phase.

#### SWITCH

Flush mounted toggle switch is located at side of machine. If desired, for convenience sake, this switch can be easily moved to the opposite side of the machine without any special tools for modification of machine enclosure.

#### TIMER

Splash proof timer furnished (in single phase only) at a slight additional charge. Timer adjustment from 0 to 5 minutes and has a "hold" position for continuous machine operation.

#### DRIVE

Dual V-belt provides proper speed reduction between the motor and the abrasive peeling disc for proper and efficient peeling action. V-belts furnished are of standard size so that if replacement is necessary, these are readily available at local hardware stores or gas stations. Belt adjustment or replacement can be accomplished without dismantling the machine. Stainless steel drive shaft is mounted on sealed, splash proof, self-lubricating ball bearings. Design of the machine, coupled with seal system, insures water tight drive area.

#### ABRASIVE DISC

A heavy duty, rust-free cast aluminum abrasive peeling disc is furnished. Abrasive carborundum is permanently cast into the disc. Aluminum provides proper strength for long life, yet is light in weight for ease in removal.

#### PEEL TRAP

A deluxe stainless steel peel trap strainer basket is included as standard equipment. Stainless steel insures resistance to rust and eliminates possibility of necessary replacement in the future; also provides necessary strength to resist daily abuse through cleaning.

#### APPROX. SHIPPING WEIGHTS

Domestic crated	205 lbs. 93 kg	Export cube	33.4 ft. .95m <sup>3</sup>
Export crated	242 lbs. 110 kg	(L32", W29", H62")	
Export boxed	256 lbs. 116 kg	813 mm	736 mm 1575 mm

There's no substitute for quality — in food or in finer machinery with which to prepare it.

That's why Blakeslee-Built Vegetable Peelers give you more for your dollar. They're built solid. Each component is perfectly honed and precision-engineered to last for years and years. For Blakeslee has built into these Peelers extra protection for parts... greater safety in handling for the operator... superior construction for longer life.

# Blakeslee Potato and Vegetable Peeler

## MODEL XC-60 & XC-60T

Compare Blakeslee feature for feature  
with any other make of peeler...



**EASY-TO-CLEAN, CAST ALUMINUM DISCHARGE CHUTE**

Hinged door operates with fingertip ease. Door requires no gaskets — eliminating gasket wearout with resulting water seepage past the door. Trough furnished in discharge chute to catch seepage, returning it to machine. Door is self-closing when released from open position.

Reinforced rim of peeling chamber and water spigot are precision-built to withstand hardest service without impairment. Another example of extra-value Blakeslee design and engineering.

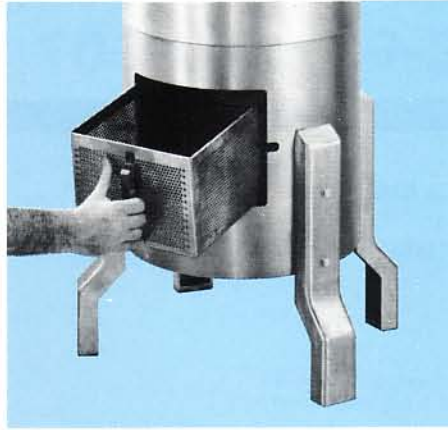

**DELUXE STAINLESS STEEL STRAINER BASKET**

Is standard equipment. Easy to clean out. It's extra large, sturdy. Slides in and out of chamber effortlessly.

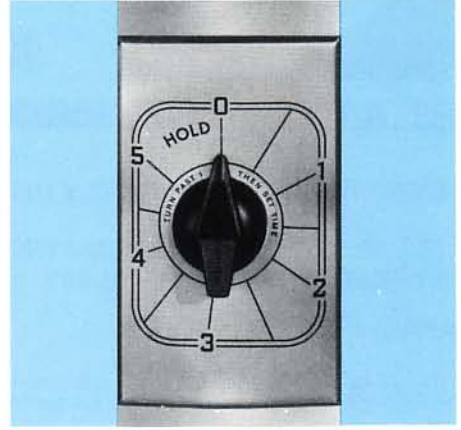

**SPLASHPROOF TIMER HAS ADJUSTMENT**

From 0 to 5 minutes and has a "hold" position for continuous machine operation. (Can be furnished in place of switch in 60-cycle, single phase motor only at slight additional charge.)

**MODEL XC-60T** furnished with a timer with a 0 to 5 minute adjustment and a "hold" position for continuous operation. (Single phase only)

**MODEL XC-60** supplied with an "on and off" switch in lieu of timer. (Single or 3 phase).

All Blakeslee peelers are designed to be in compliance with NSF, UL, CSA & ASSE Standards.

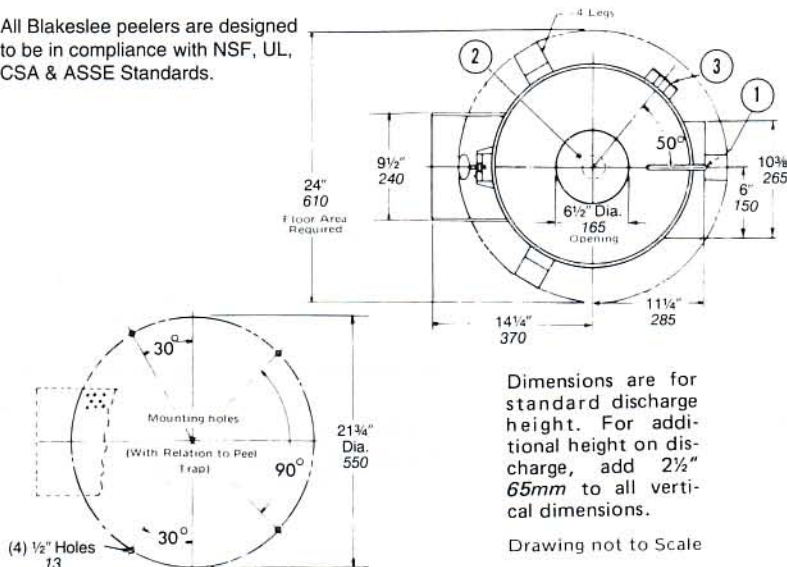

No.	Connection	Fitting	Function
1	Cold Water	1/2" 13mm I.P.S.	Peel Flushing Spray
2	Waste-Sewer	2" 50mm N.P.T.	Cylinder Drain
3	Electrical	1 H.P. Motor	3-Wire-3" 75mm Electrical Box

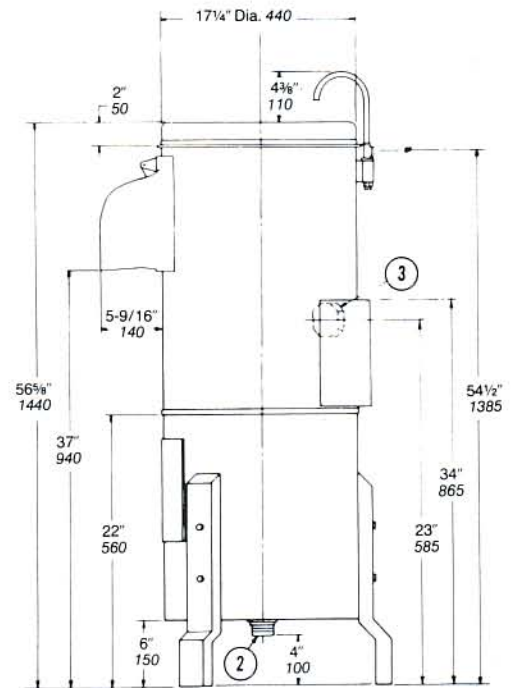

### BLAKESLEE

1844 South Laramie Avenue  
Chicago, IL 60650  
Phone: (708) 656-0660  
FAX: (708) 656-0017

### BLAKESLEE

66 Crockford Boulevard  
Scarborough, Ontario, Canada M1R 3C3  
Phone: (416) 751-2625  
FAX: (416) 751-8539

Printed in U.S.A.  
11-93-5M-TR