

BC-20E

Electric Combination-Oven/Steamer



OPTIONS AND ACCESSORIES

(AT ADDITIONAL CHARGE)

- **Additional transport cart (shelves not included)**
 - TC10 - 10 shelf position
 - TC14 - 14 shelf position
 - TC20 - 20 shelf position
 - 96 plate banquet cart
- Locking control panel
- Locking door hasp
- Tamper proof screws
- Solid door (no glass)
- Additional stainless steel wire shelves
- Core temperature probe with digital readout
- 6-1/2" (165.1mm) seismic legs
- Chicken roasting rack
- Extended warranty

Project _____

Item No. _____

Quantity _____

BC-20E

All data is shown per oven section, unless otherwise indicated.

Refer to operator manual specification chart for listed model name.

EXTERIOR CONSTRUCTION

- Stainless steel top, front, sides and back
- Stainless steel door, right hand hinge only
- Tempered viewing windows
- Condensate drip pan on oven transport cart

INTERIOR CONSTRUCTION

- Fully welded stainless steel frame
- Fully insulated cooking chamber
- Fixed drain bottom center of cavity
- Easily replaceable oven mounted door gasket

OPERATION

- MenuSelect control can hold multi-stage programming for up to 99 products, includes Cook & Hold and core probe cooking
- Two speed fan
- Magnetic door interlock switch shuts off oven when door is opened
- Automatic temperature control
- Open vented system. Condenses steam and drains away by-products of the cooking process, eliminates flavor transfer
- Automatic steam regulation
- Self-contained, self-flushing steam generator separate from cooking compartment for instant steam recovery when switching modes
- Delimiting light flashes when steam generator requires delimiting

CAPACITY

- TC14 - 28 steam table pans or 14 bake pans
- TC20 - 20 steam table pans or 20 bake pans
- TC10 Prison Cart - 20 steam table pans or 10 bake pans

STANDARD FEATURES

- Ten (10) stainless steel wire shelves
- Internal Semi-Automatic Delimiting pump with delivery hose and delimiting container
- Pressure spray bottle
- Hose and spray assembly for interior cleaning
- TC14 transport cart (14 shelf positions)
- Factory installed water pressure regulator and vented drain assembly (2 per section)
- Start-up inspection service by factory authorized service agent - operational testing and installation inspection
- One year parts and labor oven warranty*

* For all international markets, contact your local distributor.



BLODGETT COMBI

www.blodgett.com

44 Lakeside Avenue, Burlington, VT 05401 • Toll Free: (800) 331-5842 • Phone: (802) 860-3700 • Fax: (802) 864-0183

BC-20E

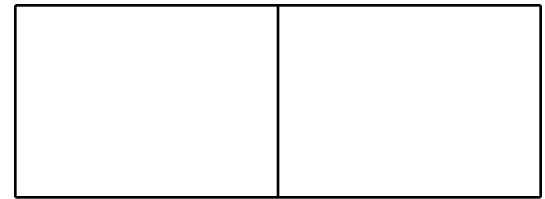

APPROVAL/STAMP

Dimensions are in inches (mm).

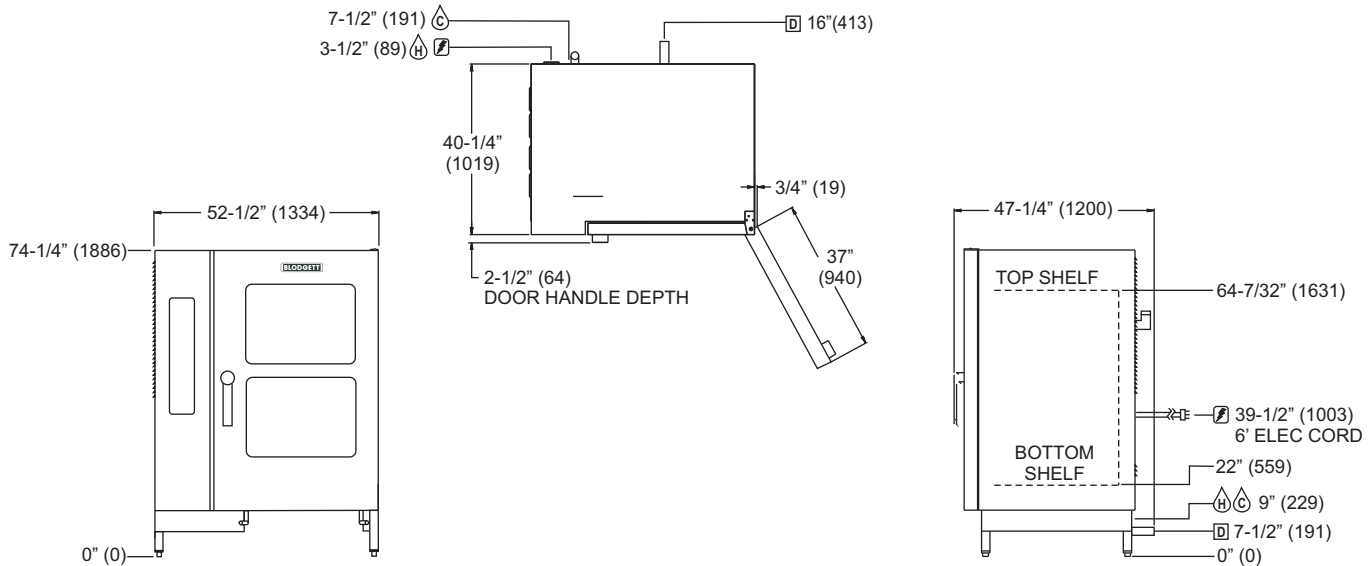

SHORT FORM SPECIFICATIONS

Provide Blodgett Combi model BC-20E single or double, electric combination-oven/steamer. Unit shall have the ability to cook with pressureless steam, hot air, or combination of steam and hot air. Unit shall allow the operator to choose four modes, steam, hot air, combi, retherm or cool down mode. Unit shall utilize a roll-in cart capable of being used in conjunction with a blast chiller or warming unit. Unit shall include two speed fan, steam on demand feature, and delimiting indicator light. The interior shall have the capability of being hosed down for cleaning. Door gaskets shall be easily removable for replacement and cleaning. Unit shall be open vented for waist air quenching. Steam generator shall be separate from the cooking compartment in order to provide the fastest possible steam recovery. Steam generator shall flush automatically to cut down on mineral build up. Unit shall include Delimiting container with semi-automatic pump for storing and dispensing delimiting solution. A start-up inspection service will be performed by our factory authorized agent at no cost to the operator.

DIMENSIONS:

Floor space: 47-1/4" D x 52-1/2" W (1200.2 x 1333.5mm)
Height: 77-1/4" (162.2mm)

OVEN CLEARANCES:

Right Side 1" (25.4mm) from equipment
 6" (152.4mm) from wall
 Rear 6" (152.4mm)
 Left Side 4" (102mm)

Blodgett recommends 12" (305mm) be maintained on the control side for servicing.

MINIMUM ENTRY CLEARANCE:

Uncrated 47-1/4" (1200mm)
 Crated 49-1/4" (1251mm)

SHIPPING INFORMATION:

Approx. Weight:

BC-20E 1200 lbs. (544 kg)
 Transport Cart 135 lbs. (61 kg)

Crate sizes:

61" (1549.4mm) x 49" (1244.6mm) x 79" (2006.6mm)

POWER SUPPLY:

208VAC 60 Hz 61KW 3 phase (170 amp)
 240VAC 60 Hz 61KW 3 phase (147 amp)

MAXIMUM INPUT:

Steam 45 kW
 Hot Air 60 kW
 Combi 60 kW

WATER SUPPLY & DRAIN:

Water Supply: Good quality water feed is the responsibility of the owner. Water quality must be within the following general guidelines.

TDS: < 100 ppm **Hardness:** 80-120 ppm **pH:** 7.0 - 8.0
Chlorides: < 30 ppm **Pressure:** 40(min)-50(max) PSI **Chlorine:** 0 ppm
 3/4" hose cold water connection (hot or filtered water optional)

The best defense against poor water quality is a water filter system designed to meet your water quality conditions. Blodgett offers an optional water filter from Terry Corp. for this unit. For further advice and support, contact Terry at 800-557-3449.

Drain:

2" drain connection 122°F (50°C) avg. drain temp.

Appliance is to be installed with backflow protection in accordance with Federal, State or Local codes.

NOTE: The company reserves the right to make substitutions of components without prior notice

BLODGETT COMBI

www.blodgett.com

44 Lakeside Avenue, Burlington, VT 05401 Toll Free: (800) 331-5842 • Phone: (802) 860-3700 • Fax: (802) 864-0183