

COS-101
Combination-Oven/Steamer**OPTIONS AND ACCESSORIES**
(AT ADDITIONAL CHARGE)

- **Legs**
 - 4" (101.6mm) adjustable legs
 - 6" (152.4mm) adjustable legs
 - 6" (152.4mm) seismic legs
 - 25" (635mm) adjustable legs
- Floor stand with pan storage
- Stand mount casters
- 480VAC, 3 phase
- Digital controls with cook and hold and Vario Steam®
- Venting kit for stacking on Blodgett full-size convection oven
- Side shield for control compartment protection, recommended when installed near another heat or water source
- Locking control panel
- Locking door hasp
- Tamper proof screws
- Additional stainless steel wire shelves
- Chicken roasting rack
- Core temperature probe with digital readout
- Left hinged door
- Stainless steel back panel
- Extended warranty

Project _____

Item No. _____

Quantity _____

All data is shown per oven section, unless otherwise indicated.
Refer to operator manual specification chart for listed model name.

EXTERIOR CONSTRUCTION

- Stainless steel top, front and sides
- Stainless steel door, right hand hinge
- Tempered viewing window
- Door mounted condensate trough

INTERIOR CONSTRUCTION

- Fully welded stainless steel frame
- Fully insulated cooking chamber
- Fixed drain bottom center of cavity

OPERATION

- Tilt down control panel for service access
- Modular controls allow for field upgrade to digital controls
- Standard control with four function selection switch for steam, hot air, combined steam/hot air and cool down
- Solid state rotary dial thermostat - range 150-500°F (66-260°C)
- Synchronous motor driven 120 minute timer
- Automatic shut-down at elapsed time with audible buzzer which continues until manually shut off
- Door interlock switch shuts off oven when door is opened
- Open vented system
- Waste air quenching. Condenses steam and drains away by-products of the cooking process, eliminates flavor transfer
- Automatic steam regulation
- Self-contained, self-flushing steam generator separate from cooking compartment for instant steam recovery when switching modes
- External decalcifying access
- Cooling fan protects controls
- Maximum capacity - 8 steam table pans, 8 half size bake pans

STANDARD FEATURES

- Five (5) stainless steel wire shelves
- Eight (8) position pan holder (ten position available in lieu of eight position)
- Pressure spray bottle
- Hose and spray assembly for interior cleaning
- Factory installed water pressure regulator and vented drain assembly
- Start-up inspection service by factory authorized service agent - operational testing and installation inspection
- One year parts and labor oven warranty*

* For all international markets, contact your local distributor.

**BLODGETT COMBI**
www.blodgett.com44 Lakeside Avenue, Burlington, VT 05401
Toll Free: (800) 331-5842 • Phone: (802) 860-3700 • Fax: (802) 864-0183

COS-101



APPROVAL/STAMP

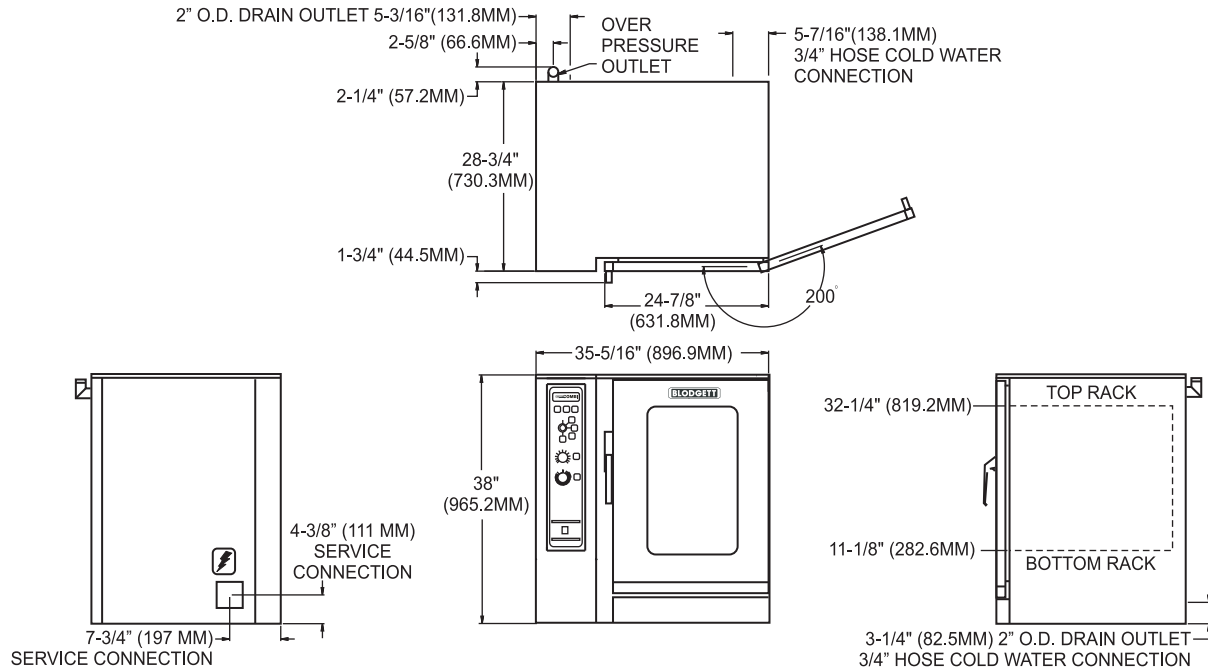

SHORT FORM SPECIFICATIONS

Provide Blodgett Combi standard model COS-101 combination-oven/steamer. Unit shall have the ability to cook with pressureless steam, hot air, or combination of steam and hot air. The interior of the unit(s) shall have the capability of being hosed down for cleaning. Unit shall have a rapid cool down mode. Unit shall be open vented for waste-air quenching. Steam generator shall be separate from the cooking compartment. Steam generator shall drain and flush automatically. Provide start-up inspection service by a factory authorized service agent.

DIMENSIONS:

- Floor space:** 35-3/8" D x 35-5/16" W (898.5 x 896.9mm)
- Unit Height:** 38" (965.2mm)
- Additional Height:**
 - 4" adjustable legs 4-7/8" - 6" (123.8-152.4mm)
 - 6" adjustable legs 6-7/8" - 8" (174.6-203.2mm)
 - 6" adjustable seismic legs 6-5/8" - 8" (168.3-203.2mm)
 - 25" adjustable legs 25-1/4" - 26-3/8" (641.4-670mm)
 - Caster plate 4-1/4" (108mm)
 - Stand w/pan guides 31" - 32-1/4" (787.4-819.2mm)
 - Stand w/pan guides on casters 31.2" (793mm)

OVEN CLEARANCES:

- Right Side 1" (25.4mm)
- Rear 4" (101.6mm)
- Left Side 4" (101.6mm) with casters
12" (304.9mm) without casters

MINIMUM ENTRY CLEARANCE:

- Uncrated 35-3/8" (898.5mm)
- Crated 42" (1067mm)

SHIPPING INFORMATION:

- Approx. Weight:**
 - Single section 515 lbs. (234 kg)
 - Stand w/guides 88 lbs. (40 kg)
- Crate sizes:** 55" (1397mm) x 42" (1067mm) x 44" (1118mm)

POWER SUPPLY:

- 208VAC 18.5KW 1 phase (89 amp) or 3 phase (52 amp)
- 240VAC 18.5KW 1 phase (77 amp) or 3 phase (45 amp)
- 480VAC 18.5 3 phase (22 amp)

This oven may contain a mercury relay. DO NOT put mercury relay in trash. Relay must be recycled or disposed of as hazardous waste.

WATER SUPPLY:

- TDS: < 100 ppm Hardness: 80-120 ppm pH: 7.0 - 8.0
- Chlorides: < 30 ppm 40(min)-50(max) PSI 122°F (50°C) avg. drain temp.
- 2" drain connection 3/4" hose cold water
- Appliance is to be installed with backflow protection in accordance with Federal, State or Local codes.

NOTE: The company reserves the right to make substitutions of components without prior notice

BLODGETT COMBI

www.blodgett.com

44 Lakeside Avenue, Burlington, VT 05401

Toll Free: (800) 331-5842 • Phone: (802) 860-3700 • Fax: (802) 864-0183