



KLT-12G

Gas Floor Model Tilting Kettle



KLT-12G FLOOR MODEL TILTING KETTLE

Project _____
Item No. _____
Quantity _____

- Model KLT-12G - 12 gallon (45 litres) gas tilting floor model kettle

CONSTRUCTION

- Water resistant construction
- 304 stainless steel construction
- 316 stainless steel interior cooking surface for added corrosion resistance
- 2/3 jacketed with factory sealed distilled water enclosure
- Hemispherical design on bottom of kettle for superior heat circulation
- Stainless steel control housing
- Four stainless steel tubular legs fitted with a four hole adjustable foot for securing the unit to the floor

OPERATION

- Gas self-generated closed steam system
- Electronic ignition
- Integrally mounted controls
- Power switch
- Thermostat
- Cook indicator light
- Ignition light
- Pressure gauge
- Water site glass
- Safety valve
- Low water light
- Low water shut off
- 150-285°F (66-140°C) temperature range

STANDARD FEATURES

- Removable operating handle with heat proof knob
- "Clean Lock" holds kettle in cooking position or 105° for ease of cleaning
- Manual control
- Stainless steel faucet bracket
- 120 VAC, 1 phase, 60 Hz
- One year parts and labor warranty*

* For all international markets, contact your local distributor.

OPTIONS AND ACCESSORIES
(AT ADDITIONAL CHARGE)

- **Faucets**
 - Single pantry faucet with swing spout
 - Double pantry faucet with swing spout
- **Etched markings**
 - Gallons
 - Litres
- One piece stainless steel lift off cover
- Stainless steel perforated basket
- 220VAC, 1 phase, 60 Hz





KLT-12G FLOOR MODEL TILTING KETTLE

APPROVAL/STAMP

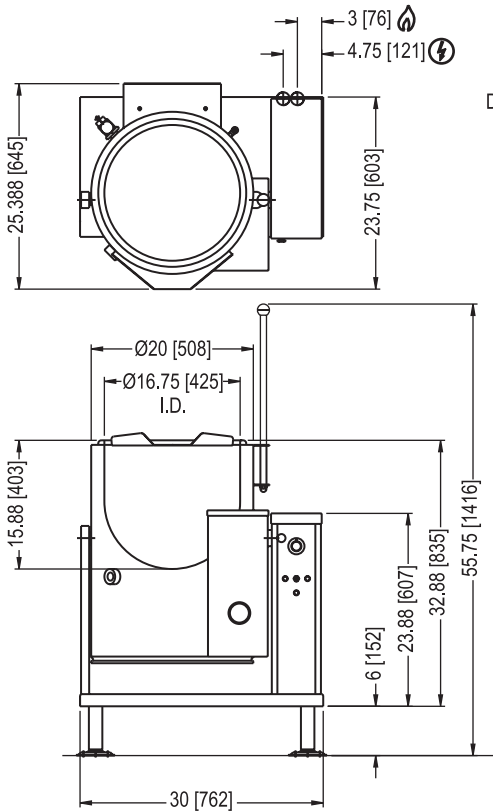

DIMENSIONS ARE IN INCHES [MM]



FLANGED FOOT DETAIL
 4 EQUALLY SPACED
 Ø7/16" [11mm] HOLES
 ON 3 [76] B.C.

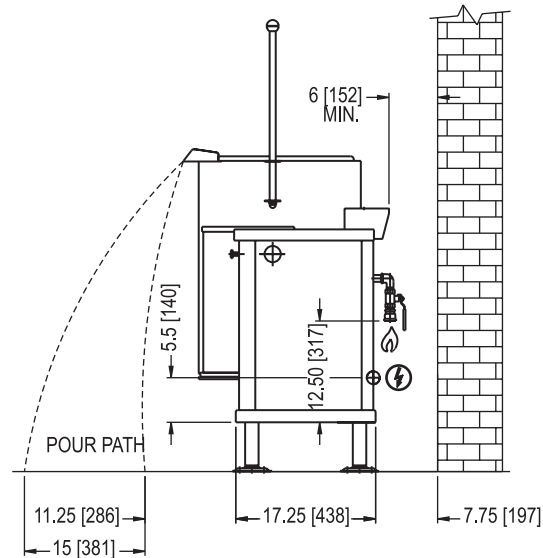

SHORT FORM SPECIFICATIONS

Provide Blodgett model KLT-12G (12 gallon) electrically heated floor model tilting kettle. The unit shall have a double wall interior to form a steam jacket around the lower 2/3 of the kettle. The jacket enclosure shall contain distilled water which is factory sealed. The bottom of the kettle shall be of hemispherical design for superior heat circulation. The unit shall include four stainless steel tubular legs fitted with a four hole adjustable foot for securing the unit to the floor. The unit shall have a removable operating handle with heat proof knob mounted on the right. Construction shall be of all welded #4 finish 304 stainless steel. The interior cooking surface shall be 316 stainless steel. The controls shall be integrally mounted, and shall include a power switch, electronic ignition, thermostat with range of 150-285°F (66-140°C), a cook indicator light, pressure gauge, safety valve, low water light and low water shut off. The burners shall turn off automatically when the kettle is tilted. Unit shall be ASME code stamped and National Board registered. Provide options and accessories as indicated.

MAXIMUM INPUT:

KLT-12G 43,000 BTU

GAS SUPPLY:

3/4" pipe

Minimum Inlet Pressure:

Natural 6.0" W.C. static to unit
 Propane 12.0" W.C. static to unit

POWER CONNECTION:

Unless other specified, electrical connection to be 120 VAC, 2 amp, 1 phase, 60 Hz, with grounding wire. Unit furnished with 6' cord and 3 prong plug)

SHIPPING INFORMATION:

Approx. Weight:

KLT-12G 285 lbs. (129 kg)

NOTE: The company reserves the right to make substitutions of components without prior notice.

BLODGETT

44 Lakeside Avenue, Burlington, VT 05401

Toll Free: (800) 331-5842 • Phone: (802) 860-3700 • Fax: (802) 864-0183