



XR8-G Rotating Rack Oven



APPROVAL/STAMP

DIMENSIONS ARE IN INCHES (MM)

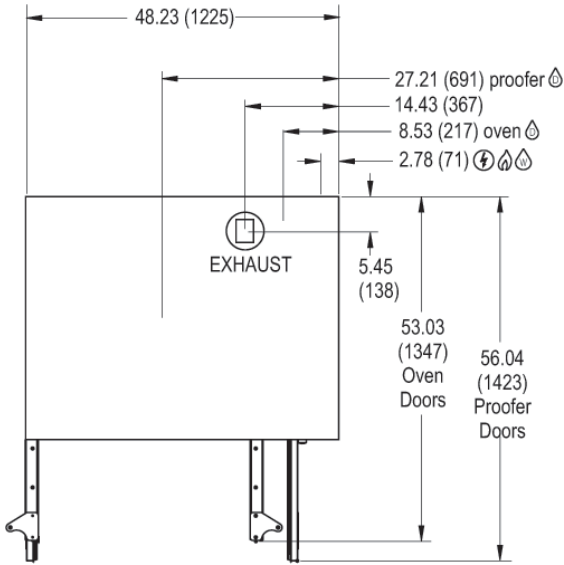

TOP VIEW WITH OPTIONAL PROOFER

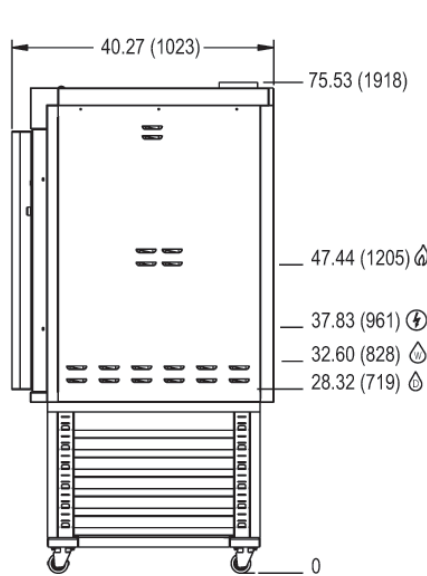

SIDE VIEW WITH STAND

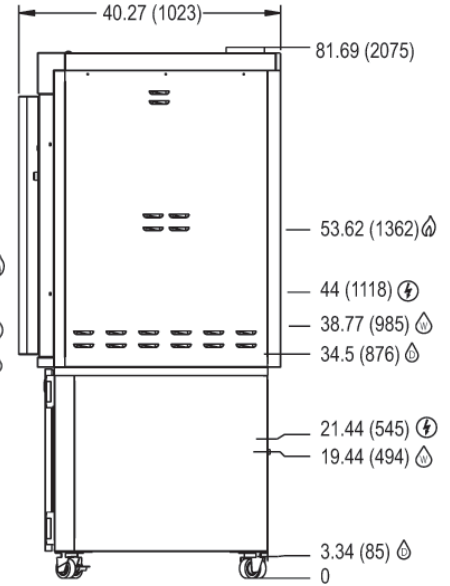

SIDE VIEW WITH OPTIONAL PROOFER

SHORT FORM SPECIFICATIONS

Provide Blodgett gas mini rotating rack bakery oven model XR8-G. Unit shall have a single compartment with fully welded angle iron frame, and 304 stainless steel interior. Unit shall accept eight 18" x 26" standard full-size bake pans and have rack slides with spacing that can be adjusted without tools in any configuration using 1" increments. Rotating rack shall be removable without tools. Unit shall have stainless steel front, top and sides. Doors shall be stainless steel, independent design with dual pane thermal glass windows. Unit shall be gas heated with electronic spark ignition and shall cook by means of indirect fired inshot burners. Unit shall have internal steamer system with pre-plumbed water lines. Unit shall be fitted with four side mounted, halogen lamps. Control panel shall be digital programmable controls, separate bake and steam times, cool-down mode, and blower delay. Manual gas service cut-off switch on front panel. Two year oven parts and labor warranty. Provide options and accessories as indicated.

DIMENSIONS:

Floor space 48.23" (1225 mm) W x 40.27" (1023 mm) D
Interior 32" (813 mm) W x 32" (813 mm) D
Product clearance
 0" from combustible and non-combustible construction

GAS SUPPLY:

3/4" NPT
 Manifold Pressure:
 • Natural – 3.5" W.C. • Propane – 10" W.C.
 Inlet Pressure:
 • Natural – 5.0" W.C. min. – 14.0" W.C. max.
 • Propane – 11.0" W.C. min. – 14.0" W.C. max.

MAXIMUM INPUT:

XR8-G 110,000 BTU/hr

POWER SUPPLY:

XR8-G 120V, 60Hz, 1 phase, 15 amp maximum dedicated circuit
 XBP-16 Proofer 120V, 60Hz, 1 phase, 15 amp maximum dedicated circuit

NOTE: The company reserves the right to make substitutions of components without prior notice

COLD WATER SUPPLY:

Pipe Size 3/4" GHT
 Pressure 30-75 psi. (21-52 kPa) minimum
 Flow Rate 1.12 gal/min (4.5 liters/min.)

DRAIN:

XR8-G 3/4" NPT rear drain connection
 XBP-16 proofer 3/4" NPT rear drain connection

MINIMUM ENTRY CLEARANCE:

Uncrated* 33" (838 mm)
 Crated 49.25" (1251mm)

* Unit will fit through standard 36" door with the doors, control panel, and back panel removed

SHIPPING INFORMATION:

Approx. Weight:

XR8-G 810 lbs. (367 kg)
 XBP-16 proofer 425 lbs. (198 kg)
 Stand 119 lbs. (54 kg)

Crate sizes:

XR8-G 49.25" (1251mm) x 54.25" (1378mm)
 XBP-16 proofer 42.5" (1080mm) x 54.25" (1378mm)