

BLODGETT RANGE

IMPORTANT FOR FUTURE REFERENCE

Please complete this information and retain this manual for the life of the equipment:

Model #: _____

Serial #: _____

Date Purchased: _____

OPERATOR'S MANUAL

Model B16-FR45 and B20-FR65

Sectional Deep Fryer

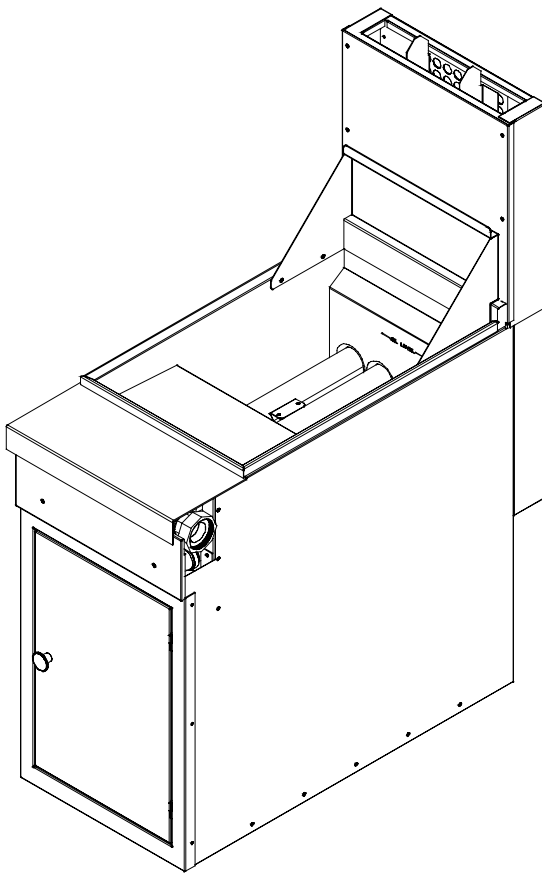

Model B16-FR45

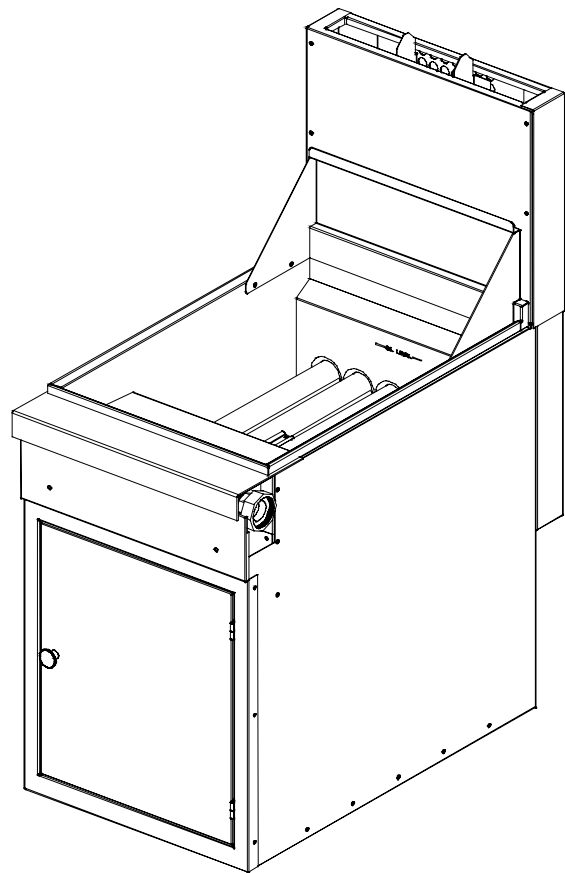

Model B20-FR65

! WARNING

Improper installation, adjustment, alteration, service or maintenance can cause property damage, injury or death. Read the installation, operating and maintenance instructions thoroughly before installing or servicing this equipment.

1100 Old Honeycutt Road, Fuquay-Varina, NC 27526
www.blodgettrange.com

MANUAL 1184959
\$18.00



SECTIONAL DEEP FRYER
MANUAL SECTION SR

SAFETY PRECAUTIONS

Before installing and operating this equipment, be sure everyone involved in its operation is fully trained and aware of precautions. Accidents and problems can be caused by failure to follow fundamental rules and precautions.

The following symbols, found throughout this manual, alert you to potentially dangerous conditions to the operator, service personnel, or to the equipment.



This symbol warns of immediate hazards that will result in severe injury or death.



This symbol refers to a potential hazard or unsafe practice that could result in injury or death.



This symbol refers to a potential hazard or unsafe practice that could result in injury, product damage, or property damage.



This symbol refers to information that needs special attention or must be fully understood, even though not dangerous.

WARNING **FIRE HAZARD** **FOR YOUR SAFETY**

Do not store or use gasoline or other flammable vapors and liquids in the vicinity of this or any other appliance.

Keep area around appliances free and clear of combustibles.

Purchaser of equipment must post in a prominent location, detailed instructions to be followed in the event the operator smells gas. Obtain the instructions from the local gas supplier.

WARNING **BURN HAZARD**

Contact with hot oil will cause severe burns. Always use caution. Oil at 200°F is more dangerous than boiling water.

WARNING

In the event a gas odor is detected, shut down equipment at the combination gas valve and contact the local gas company or gas supplier for service.

NOTICE

Blodgett Range Sectional Deep Fryers are intended for commercial use only. Not for household use.

Warranty will be void if service work is performed by other than a qualified technician, or if other than genuine Southbend replacement parts are installed.

Be sure this Operator's Manual and important papers are given to the proper authority to retain for future reference.

Congratulations! You have purchased one of the finest pieces of heavy-duty commercial cooking equipment on the market.

You will find that your new equipment, like all Blodgett Range equipment, has been designed and manufactured to meet the toughest standards in the industry. Each piece of Blodgett Range equipment is carefully engineered and designs are verified through laboratory tests and field installations. With proper care and field maintenance, you will experience years of reliable, trouble-free operation. **For best results, read this manual carefully.**

RETAIN THIS MANUAL FOR FUTURE REFERENCE.

MODEL NUMBERS

This manual is for the Blodgett Range Sectional Deep Fryer models B16-FR45 and B20-FR65, which can be ordered with a front-to-back depth of 36" or 42". The serial plate is located inside the front door on the left side.

Table of Contents

Specifications 4

Installation 7

Operation 14

Cooking Hints 17

Cleaning 19

Service 22

Parts 27

Read these instructions carefully before attempting installation. Installation and initial startup should be performed by a qualified installer. Unless the installation instructions for this product are followed by a qualified service technician (a person experienced in and knowledgeable with the installation of commercial gas an/or electric cooking equipment) then the terms and conditions on the Manufacturer's Limited Warranty will be rendered void and no warranty of any kind shall apply.

In the event you have questions concerning the installation, use, care, or service of the product, write to:

Blodgett Range
1100 Old Honeycutt Road
Fuquay-Varina, North Carolina 27526 USA



SPECIFICATIONS

DIMENSIONS OF MODEL B16-FR45

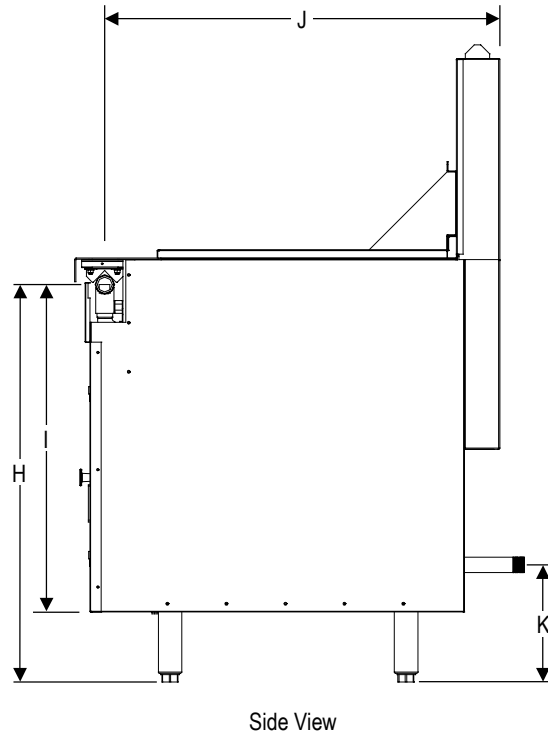
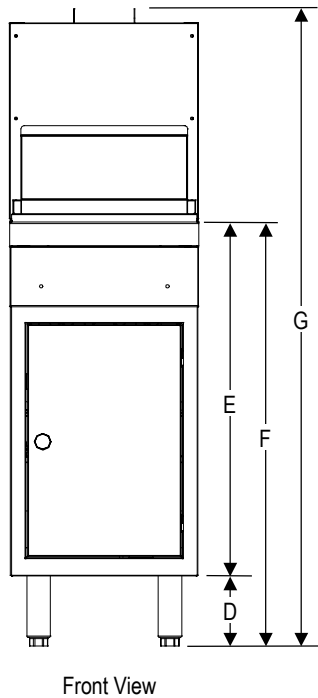
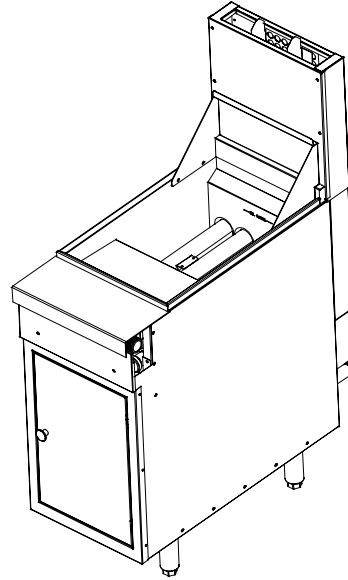
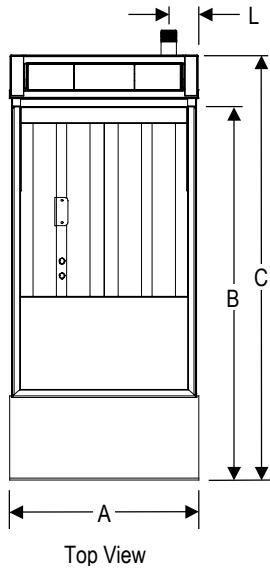

Depth Option	Width	Depth		Height				Front Gas Connection			Rear Gas Conn.		Crated Weight
	A	B	C	D	E	F	G	H	I	J	K	L	
36"	16.0" (406)	31.8 (808)	36.0" (914)	6.0" (152)	30.0" (762)	36.0" (914)	54.0" (1372)	33.8 (859)	27.8 (706)	33.5 (851)	9.5" (241)	2.0" (51)	219 lbs 99 kg
42"	16.0" (406)	37.8 (960)	42.0" (1067)	6.0" (152)	30.0" (762)	36.0" (914)	54.0" (1372)	33.8 (859)	27.8 (706)	39.5 (1003)	9.5" (241)	2.0" (51)	222 lbs 101 kg



DIMENSIONS OF MODEL B20-FR65

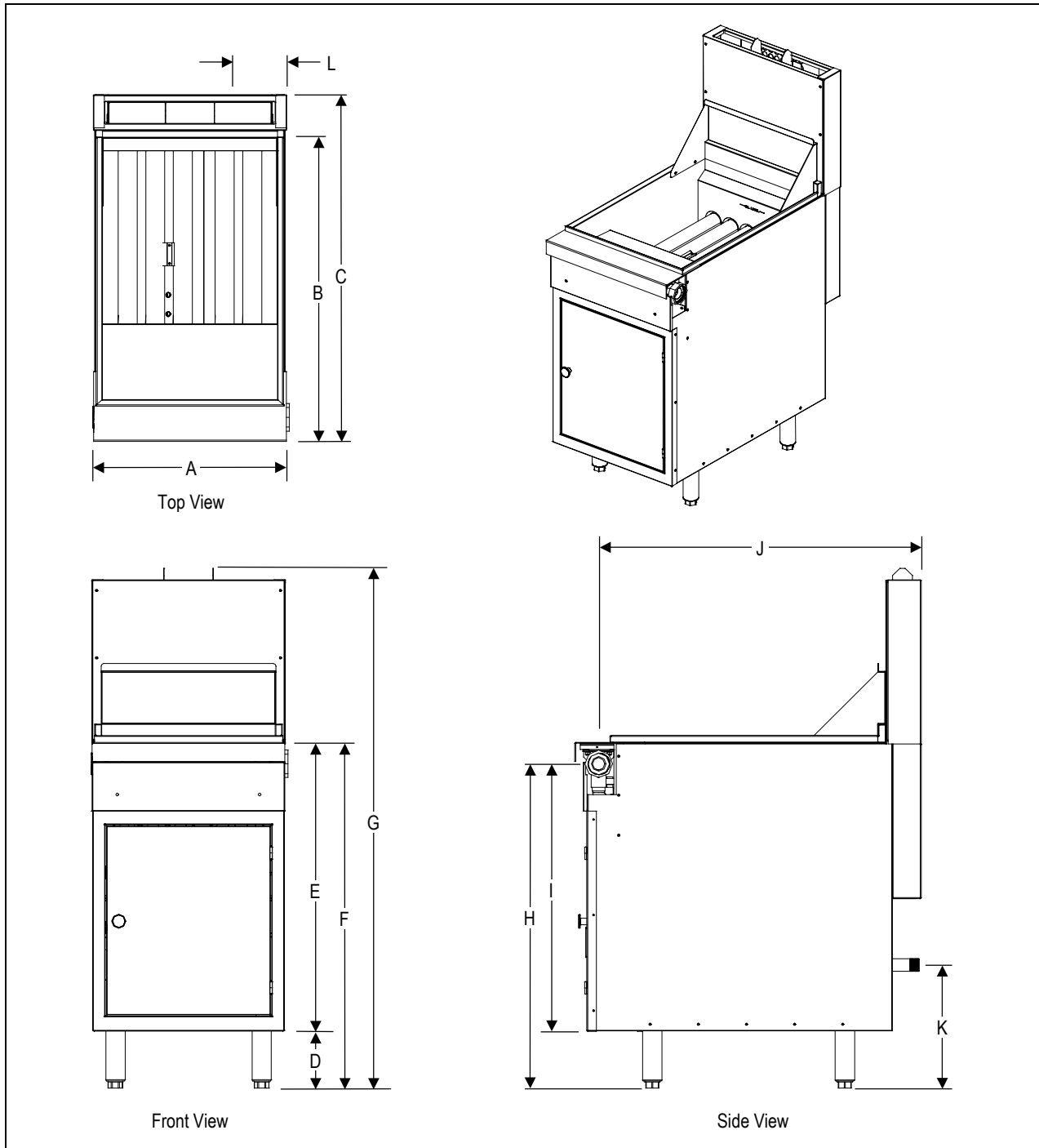

Depth Option	Width	Depth		Height				Front Gas Connection			Rear Gas Conn.	Crated Weight	
	A	B	C	D	E	F	G	H	I	J	K		L
36"	20.0" (508)	31.8 (808)	36.0" (914)	6.0" (152)	30.0" (762)	36.0" (914)	54.0" (1372)	33.8 (859)	27.8 (706)	33.5 (851)	12.8" (325)	4.5" (114)	229 lbs 104 kg
42"	20.0" (508)	37.8 (960)	42.0" (1067)	6.0" (152)	30.0" (762)	36.0" (914)	54.0" (1372)	33.8 (859)	27.8 (706)	39.5 (1003)	12.8" (325)	4.5" (114)	232 lbs 105 kg



GAS SUPPLY AND BURNER INFORMATION

Supply pressure should be greater than 7" W.C. for natural gas or greater than 11" W.C. for propane. The fryer has an internal, field-convertible gas-pressure regulator. The front manifold has a 1-1/4" connector on each end (the end on the left side of the fryer is male, while the end on the right side of the fryer is female). If the fryer has the optional rear gas connection, it has a 1" NPT male connector located on back (see illustrations on pages 4, 5, and 8).

Model	Burners	Gas Type	Manifold Pressure*	Number per Unit	Rate Each BTUs/Hour	Total Rate BTUs/Hour	Orifice Size
B16-FR45	Main	Natural	4" W.C.	4	35,000	140,000	#36 - 0.1065" dia.
		Propane	10" W.C.	4	30,000	120,000	#52 - 0.0635" dia.
	Pilot	Natural	4" W.C.	1	900	900	#77 - 0.0180" dia.
		Propane	10" W.C.	1	900	900	0.0110" dia.
B20-FR65	Main	Natural	4" W.C.	5	35,000	175,000	#38 - 0.1015" dia.
		Propane	10" W.C.	5	30,000	150,000	#52 - 0.0635" dia.
	Pilot	Natural	4" W.C.	1	900	900	#77 - 0.0180" dia.
		Propane	10" W.C.	1	900	900	0.0110" dia.

* Minimum supply pressure is 7" W.C. for natural gas and 11" W.C. for propane.

** Orifice sizes are for units installed at altitudes between 0 and 2000 feet above sea level.

ELECTRICAL REQUIREMENT

No external electric power is required.

CLEARANCES

See page 12.



INSTALLATION

NOTICE

Installation must conform with local codes, or in the absence of local codes, with the *National Fuel Gas Code, ANSI Z223.1, Natural Gas Installation Code, CAN/CGA-B149.1*, or the *Propane Installation Code, CAN/CGA-B149.2*, as applicable.

NOTICE

These installation procedures must be followed by qualified personnel or warranty will be void.

Local codes regarding installation vary greatly from one area to another. The National Fire Protection Association, Inc. states in its NFPA 96 latest edition that local codes are the “authority having jurisdiction” when it comes to installation requirements for equipment.

Step 1: Unpack

IMMEDIATELY INSPECT FOR SHIPPING DAMAGE

All containers should be examined for damage before and during unloading. The freight carrier has assumed responsibility for safe transit and delivery. If damaged equipment is received, either apparent or concealed, a claim must be made with the delivering carrier.

Apparent damage or loss must be noted on the freight bill at the time of delivery. The freight bill must then be signed by the carrier representative (Driver). If the bill is not signed, the carrier may refuse the claim. The carrier can supply the necessary forms.

A request for inspection must be made to the carrier within 15 days if there is concealed damage or loss that is not apparent until after the equipment is uncrated. The carrier should arrange an inspection. Be certain to hold all contents plus all packing material.

1. Uncrate carefully. Report any hidden damage to the freight carrier IMMEDIATELY.
2. Do not remove any tags or labels until unit is installed and working properly.



Step 2: Install Flue Riser

The flue riser assembly is packed separately in the shipping crate. Attach the flue riser to the top rear of the fryer as shown in the illustration below.

INSTALLATION

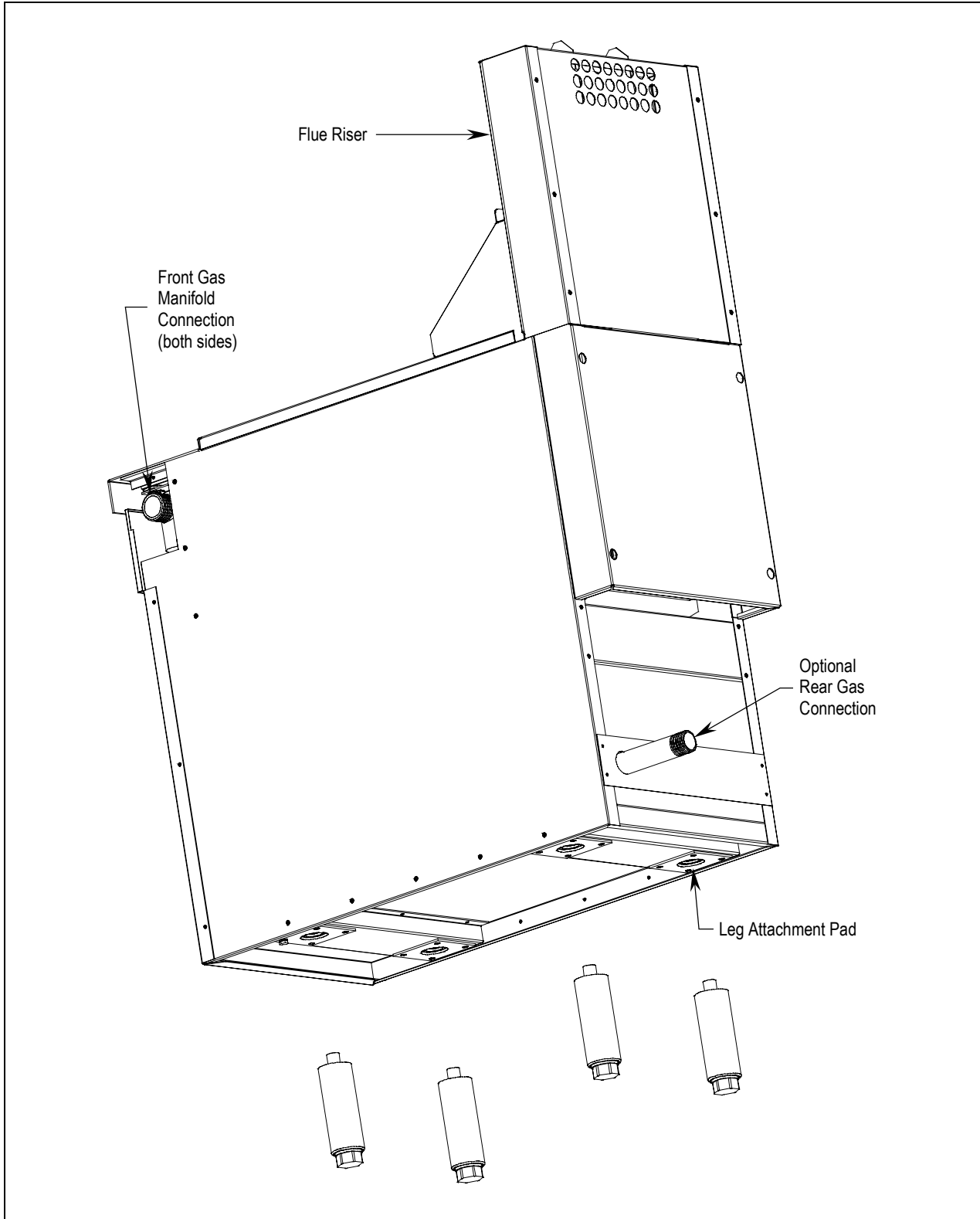



Step 3: Install the Legs (or Casters) and Restraint

A set of legs or casters is packed with the fryer. A threaded pad is fastened to the base frame at each corner (see illustration on page 8). Each leg or caster has a similar mating thread. When casters have been ordered, the casters are provided with a Zerk fitting for proper lubrication when required.

1. Raise fryer sufficiently to allow legs or casters to be screwed into the pads. For safety, “shore up” and support the fryer with an adequate blocking arrangement strong enough to support the load.
2. Screw the four legs or casters to the pads on the bottom of the fryer. When casters have been ordered, the casters having a locking-brake should be attached under the front of the fryer.
3. Lower the fryer gently. Never drop or allow the fryer to fall.
4. Use a level to make sure that the fryer is level. Each caster, or the tubular-end of each leg, can be screwed in or out to lower or raise each corner of the fryer. For fryers having casters, tighten the lock nuts after the unit has been leveled.
5. Attach restraints as required by local codes.

NOTICE

Unit must be level to assure maximum performance. Improper leveling may void warranty.

NOTICE

Adequate restraining means must be attached to rear of appliance when installed. Installation must conform to local codes as applicable.



WARNING

If disconnection of the restraint is necessary to move the appliance for cleaning, etc., reconnect it when the appliance is moved to its original installed position.



WARNING

For an appliance equipped with casters, the installation shall be made with a connector that complies with the Standard for *Connectors for Movable Gas Appliances, ANSI Z21.69* or *Connectors for Moveable Gas Appliances, CAN/CGA-6.16*, and a quick-disconnect device that complies with the Standard for *Quick-Disconnect Devices for Use With Gas Fuel, ANSI Z21.41*, or *Quick Disconnect Devices for Use with Gas Fuel, CAN1-6.9*. Adequate means must be provided to limit the movement of the appliance without depending on the connector and the quick-disconnect device or its associated piping to limit the appliance movement.



WARNING

All fryers must be restrained to prevent tipping in order to avoid the splashing of hot liquid. The means of restraint may be the manner of installation, such as connection to a battery of appliances or installing the fryer in an alcove, or by separate means, such as adequate ties.



Step 4: Assembly of Fryer as Part of a Battery

If the fryer is to be assembled with other units as part of a battery, do the following:

1. Position the center range of the battery and carefully level that unit. Use a long spirit level four ways; across front top rail and the rear collar plate, and along each edge.
2. Remove all front valve panels. Mark them so that they can be returned to their respective unit.
3. Bring up adjacent unit and level it using the same method and by using the center unit as reference. Match front rails and rear collar plates. When a battery is set on a masonry base and legs are not used, shims may be used. Special attention should be given to Fry Top ranges to allow proper drainage on griddles.
4. Where spreader plates are installed, refer to Sectional Battery Component Assembly Instructions supplied with each unit.
5. Connect and test the gas supply as described in Step 5, then re-install the valve panels.

Step 5: Gas Connection

The fryer has a 1-1/4" gas supply manifold located inside the top front edge and an optional 1" a rear gas connection (see illustrations on pages 8, 35, and 37). Depending on the customer's specification when the unit was purchased, the ends of the gas supply manifold may both be open (for connection to adjacent units on both sides), one may be open (for connection to one adjacent unit), or neither may be open (for a freestanding fryer). The optional rear gas connection may be present for use by a freestanding fryer, or as a supply connection for a battery.

The serial plate (located inside the front door of the fryer) indicates the type of gas the unit is equipped to burn (natural gas or propane). The fryer should be connected **ONLY** to the type of gas for which it is equipped.

All Blodgett Range equipment is adjusted at the factory; however, pilot height should be checked at installation and adjusted, if necessary (see page 24).

For orifice sizes and pressure regulator settings, see the chart on page 6. If the fryer is being installed at over 2,000 feet altitude and that information was not specified when ordered, contact the appropriate Authorized Service Agent or the factory service department. Failure to install with proper orifice sizing will result in poor performance and may void the warranty.

If applicable, the vent line from the gas appliance pressure regulator shall be installed to the outdoors in accordance with local codes or, in the absence of local codes, with the *National Fuel Gas Code, ANSI Z223.1, Natural Gas Installation Code, CAN/CGA-B149.1*, or the *Propane Installation Code, CAN/CGA-B149.2*, as applicable.

An adequate gas supply is imperative. Undersized or low-pressure lines will restrict the volume of gas necessary for satisfactory performance. A combination gas valve and pressure regulator, which is provided with each unit, is set to maintain a 4" W.C. manifold pressure for natural gas or 10.0" W.C. manifold pressure for propane gas. However, to maintain these conditions the pressure on the supply line, when all units are operating simultaneously, should not drop below 7" W.C. for natural gas or 11" W.C. for propane gas. Fluctuations of more than 25% on natural gas or 10% on propane gas will create problems and affect burner operating characteristics. A 1/8" tap to measure the manifold pressure is located on the burner manifold (see illustrations on pages 35 and 37).

Purge the supply line to clean out dust, dirt, or other foreign matter before connecting the line to the unit.

It is recommended that an individual manual shutoff valve be installed in the gas supply line to the unit.

Use pipe joint compound that is suitable for use with both natural and LP gas on all threaded connections.

⚠ CAUTION

ALL PIPE JOINTS AND CONNECTIONS MUST BE TESTED THOROUGHLY FOR GAS LEAKS. USE ONLY SOAPY WATER FOR TESTING ON ALL GASES. NEVER USE AN OPEN FLAME TO CHECK FOR GAS LEAKS. ALL CONNECTIONS MUST BE CHECKED FOR LEAKS AFTER THE UNIT HAS BEEN PUT INTO OPERATION. TEST PRESSURE SHOULD NOT EXCEED 14" W.C.

⚠ CAUTION

THIS APPLIANCE AND ITS INDIVIDUAL COMBINATION GAS VALVE MUST BE DISCONNECTED FROM THE GAS SUPPLY PIPING SYSTEM DURING ANY PRESSURE TESTING OF THAT SYSTEM AT TEST PRESSURES IN EXCESS OF 1/2 PSIG (3.45 kPa).

The appliance must be isolated from the gas supply piping system by closing its individual manual shutoff valve during any pressure testing of the gas supply piping system at test pressures equal to or less than 1/2 psi (3.45 kPa).

NOTE: Although the fryer is equipped with an internal pressure regulator, other sectional units in a battery may require an external pressure regulator. This pressure regulator must (1) be certified by a recognized testing agency, (2) be acceptable for total pilot load application, (3) have a maximum regulation capacity for the total connected load, and (4) have a pressure adjustment range to allow adjustment to the manifold pressure on the appliance rating plate. Unless the manifold pressure of all connected appliances is the same, a separate regulator must be supplied for each unit(s) to indicate unit or units having differing manifold pressures.

If the fryer is to be connected to adjacent units in a battery, do the following:

1. Connect the units together by mating the supply-manifold unions. Just **HAND TIGHTEN** until all units have been connected to each other.
2. Starting at the center and working toward the ends of the battery, tighten each union gradually, going from one to another, until all are finally tight. A special thin wrench, which fits the union nut, is provided with each battery, or a chain wrench can be used.
3. Connect the gas supply at right, left, or both ends. When a spreader plate with a "Tee" connection is inserted in a battery, the gas supply may be connected at this point. Units with rear connections may also be used in this respect. If five or more units are connected in one battery, more than one supply line should be used. Each supply line should have a readily accessible, approved hand shutoff valve

If the optional rear gas connection is to be used, connect the gas supply directly to the 1" male NPT connector located near the lower right rear corner of the fryer (see illustration on page 8). When tightening the supply pipe, be sure to hold the mating connector extending from the unit securely with a wrench. This will prevent any damage or distortion to the internal piping and controls of the unit.

For all installations, proceed as follows:

1. Check that all unused gas connections are capped.
2. Turn off all burner valves.
3. Turn on gas supply and immediately check all connections for leaks. **USE SOAPY WATER ONLY FOR TESTING ON ALL GASES. NEVER USE AN OPEN FLAME TO CHECK FOR GAS LEAKS.**
4. When the entire gas system has been checked, turn off gas supply during the rest of the installation.
5. After connecting the gas supply, check that the fryer is level. Use a long spirit level four ways; across the front and rear of the frypot, and along each edge.



Step 6: Check Clearances and Ventilation

Select a firm, level location for your fryer. Leave clearance, whenever possible, so that access from the rear is possible to permit cleaning. If the unit is to be set on non-combustible flooring, such as a concrete slab, 3 inches minimum toe room must be provided to prevent restriction of the air opening in the bottom of the unit.

! WARNING

There must be adequate clearance between fryer(s) and construction. Clearance must also be provided in front for servicing and for operation.

Minimum Clearances:

	From Combustible Construction	From Non-Combustible Construction
Sides	6"	0"
Rear	6"	0"

ALL DEEP FRYERS SHALL BE INSTALLED WITH AT LEAST A 16 INCH SPACE BETWEEN THE FRYER AND SURFACE FLAMES FROM ADJACENT EQUIPMENT.

No additional side and rear clearance is required for service as the fryer is serviceable from the front.

! WARNING

Improper ventilation can result in personal injury or death. Ventilation that fails to properly remove flue products can cause headaches, drowsiness, nausea, or could result in death.

All units must be installed in such a manner that the flow of combustion and ventilation air is not obstructed. Provisions for adequate air supply must also be provided. Do NOT obstruct the bottom front of the unit, as combustion air enters through this area. Be sure to inspect and clean the ventilation system according to the ventilation equipment manufacturer's instructions.

NOTICE

Proper ventilation is the owner's responsibility. Any problem due to improper ventilation will not be covered by the warranty.

Due to the variety of problems that can be caused by outside weather conditions, venting by canopies or wall fans is preferred over any type of direct venting. It is recommended that a canopy extend 6" past the appliance and the bottom edge be located 6'6" from the floor. Filters should be installed at an angle of 45° or more from the horizontal. This position prevents dripping of grease and facilitates collecting the run-off grease in a drip pan, unusually installed with a filter. A strong exhaust fan tends to create a vacuum in the room and may interfere with burner performance or may extinguish pilot flames. Fresh air openings approximately equal to the fan area will relieve such a vacuum. In case of unsatisfactory performance on any appliance, check the appliance with the exhaust fan in the "OFF" position. Do this only long enough to check equipment performance, then turn hood back on and let it run to remove any exhaust that may have accumulated during the test.

The exhaust fan should be installed at least 2 feet above the vent opening at the top of the fryer.

This unit is not intended to be connected directly to an outside flue.



Step 7: Check Installation

 **CAUTION**

IF YOU SMELL GAS DURING THE LIGHTING PROCEDURE, IMMEDIATELY SHUT OFF THE GAS SUPPLY UNTIL THE LEAK HAS BEEN CORRECTED.

The following items should be checked by a qualified service technician before or within the first 30 days of operation:

1. Verify proper type of gas.
2. Verify gas supply pressure (pressure regulator is already installed at factory).
3. Check gas supply connections.
4. Check internal gas connections.
5. Check internal electrical connections.
6. Check pilots (adjustment and ignition).
7. Check burners (adjustment and ignition).
8. Check thermostat for correct calibration; if necessary, calibrate.
9. Check for correct position of flue extension.
10. Check drain valve for correct operation.
11. Check frypot for leaks.
12. Advise user on cleaning procedures.



OPERATION

OPERATION

NOTICE

These procedures must be followed by qualified personnel or warranty will be voided.

The Blodgett Range Sectional Deep Fryer is an immersion tube fryer. This is the most efficient method of transmitting heat into the oil. The tubes are actually large heat exchangers. Each tube is heated by a burner at its front that propels its flame and heat into the tube, toward the rear, where it is vented into a flue box. The combined heat transfer area of the tubes is much greater than the other types using element coils or under-fired pots. Consequently, heat transfer per square inch is lower, as is the temperature, but because of the increased surface area, immersion tube fryers transfer more heat into the oil. The lower temperature of the heating surface prevents scorching and carbonization of the oil. Higher heat transfer rate gives faster recovery between loads.

Another advantage of immersion tube fryers is the cold zone. As oil is heated it passes between and over the tubes and rises into the frying zone, where it imparts heat into the product. After giving up heat, it descends to the cooler zone below the tubes. Food particles and crumbs are dropped and trapped in the cold zone as the oil awaits to be recirculated. The cold zone concept helps keep the oil circulating and clean of debris.

WARNING **BURN HAZARD**

Contact with hot oil will cause severe burns. Always use caution. Oil at 200°F is more dangerous than boiling water.

CAUTION

NEVER OPERATE THE FRYER WITHOUT SUFFICIENT OIL TO COVER THE TUBES.

LIGHTING

CAUTION

IF YOU SMELL GAS DURING THE LIGHTING PROCEDURE, IMMEDIATELY SHUT OFF THE GAS SUPPLY UNTIL THE LEAK HAS BEEN CORRECTED.

Open the burner compartment door and do the following:

1. Turn thermostat to "OFF" (lowest position).
2. Press down the knob of the combination gas valve, turn it counterclockwise to the "PILOT" position, and continue to press the knob down.

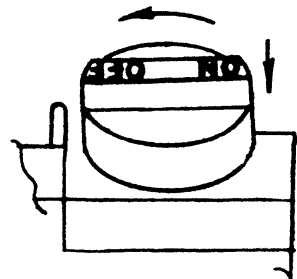



3. While pressing the knob down, use a lit match to ignite the pilot. Continue to press the knob down for about 30 seconds. If the pilot does not stay ignited when the knob is released, repeat the lighting procedure and keep the knob down longer. Adjustment of pilot flame may be necessary.
4. When the pilot stays ignited, turn the knob counterclockwise to the "ON" position. Do not press down on the knob in this step.
5. Do NOT turn the thermostat "ON" until the frypot is filled with oil or solid shortening.

SHUTDOWN PROCEDURE

Standby: Turn knob on the combination gas valve to the "PILOT" position. At this setting, only the pilot burner will remain ignited.

Complete Shutdown: Turn knob on the combination gas valve, then press down on the knob and continue to turn to the "OFF" position.

RELIGHTING

WARNING

In the event of a main burner ignition failure, a five minute purge period must be observed prior to re-establishing the ignition source.

If the pilot goes out, the gas valve will automatically close. To re-light the pilot, do the following:

1. Shut off all gas.
2. Wait five minutes.
3. Follow the "LIGHTING" procedure on page 14.

FILLING THE FRYPOT

1. Close drain valve completely before filling the frypot.
2. When the fryer is new, fill the frypot with water and clean thoroughly (see "Weekly Cleaning" on page 20) in order to remove protective coatings and any foreign matter.
3. The recommended solid shortening capacity for the fry pot is 45 pounds for model B16-FR45 units and 65 pounds for model B20-FR65 units.
4. Remove the basket support frame when filling the frypot with solid shortening.
5. When solid shortening is used, be careful not to bend, break, or twist the thin capillary wires of the sensing elements located in the right-hand front corner of the frypot.
6. Pack solid shortening into the zone below the tubes, all spaces between the tubes, and at least an inch above the top of the tubes before lighting the fryer. If any air spaces are left around the heat tube surfaces when the heat is turned on, the tube surfaces will become red hot, burn the solid shortening, weaken the frypot, and could result in a fire.

CAUTION

*NEVER ATTEMPT TO MELT A SOLID BLOCK OF SHORTENING ON TOP OF THE HEAT TUBES.
NEVER START THE BURNERS WHEN THE FRYPOT IS EMPTY.*

7. To prevent burning or scorching the solid shortening, keep the thermostat set at the lowest temperature until all the solid shortening between and above the tubes has been melted. Additional solid shortening can then be added until the desired frying depth has been reached.
8. Replace the basket support frame over the frypot heat tubes.



AUTOMATIC PILOT VALVE

The Automatic Pilot Valve provides an automatic safety shutoff for the fryer when the pilot flame is extinguished. When the pilot flame is burning, the valve is held open electromagnetically by the electrical current from a thermopile in the pilot flame. When the pilot flame goes out, generation of current ceases and the valve closes automatically.

HIGH LIMIT CONTROL

The fryer is equipped with a secondary heat control that prevents the oil temperature from rising above 450°F. (Because of the accuracy tolerance of the sensor, the oil temperature may reach as high as 475°F.)

In the event the fryer shuts down due to this condition, the oil must be cooled to below 400°F before the pilot burner can be re-ignited. When the oil has cooled, use the "LIGHTING" procedure on page 14 to place the fryer back in operation. If the problem persists, contact your Authorized Service Agent or the factory service department.

WARNING

In the event a gas odor is detected, shut down equipment at the combination gas valve and contact the local gas company or gas supplier for service.

OPERATION

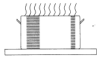

COOKING HINTS

USER TIPS

- Smoking oil means that the temperature is too high, or that the oil has broken down.
- Gum in frypot denotes a need for thorough cleaning (see “Weekly Cleaning” on page 20)
- Use different oil for oily foods (mackerel, nutmeg, etc.) than for foods with water-soluble flavors (potatoes, onions, etc.).
- Taste oil for quality. Replace it regularly.
- Poor oil cannot produce good food.

GAS SAVING TIPS

Use the following tips to help develop energy-saving procedures and habits. Using less natural or propane gas saves energy, and money, too.

- Limit preheat time to 5 to 10 minutes.
- Set thermostat to desired temperature.
- Do not overheat. Never use temperatures higher than 375°F.
- Turn fryers off during slack periods.
- Filter oil daily. Clean frypot thoroughly at least once a week (see page 20).

FRYING DO'S

- Make sure frypot is clean.
- Make sure thermostats are registering and functioning properly.
- Fill frypot only to proper frying level. An oil-level line is stamped on the frypot.
- Maintain proper level of oil in the frypot by occasionally adding fresh solid shortening as the frypot fries down.
- Keep heating tubes covered at all times when heat is on.
- Fry at temperature in the range 325°F to 375°F.
- Turn heat in the frypots to 200°F, or preferably off, between fry periods, or during any periods of time when this is practical.
- Fry foods in amounts only up to a full load; a full loading being the point where the temperature recovers to the dial setting and the thermostat turns off the burner before the food is completely fried or done.
- Remove food baskets from frypot as soon as food is done, allowing food to drain over frypot a minimum of 30 seconds.
- Keep oil as clean as possible at all times, removing immediately any floating burned particles.
- Make sure baskets are sound and don't leak food into the frypot.
- Drain frypot, filter oil, and remove all residue from cold zone at least once daily. Boil out frypot and baskets with detergent at least once a week, scraping off any foreign materials not yielding to the treatment. Rinse frypot several times by filling with fresh water and bringing to boil. Perform the weekly cleaning procedure (see page 20).
- Keep frypots covered when not in use.



FRYING DON'TS

- Don't turn on the fryer with no shortening in the frypot.
- Don't fill the frypot above the line on rear of frypot.
- Don't allow oil in frypot to fry down to the point where there is insufficient oil in which to fry a full load.
- Don't have heat on tubes when they are not entirely covered with frying oil.
- Don't allow oil in frypot to be heated above 375°F and never turn thermostats to 400°F or over, even when bringing up the temperature.
- Don't allow unnecessary moisture or breading materials to get into frypot.
- Don't allow oil in frypot to remain at frying temperature for long periods of time without frying taking place.
- Don't overload frypot with food to be fried.
- Don't pack the food too tightly in the baskets.
- Don't add foreign oils to frypot such as bacon, beef drippings, or waste oil.
- Don't fry bacon in frypot.
- Don't salt food over or near the frypot.
- Don't allow visible burned particles to remain floating in frypot.
- Don't allow exhaust stack accumulations to drip back into the frypot.

PERFORMANCE

COOKING HINTS

Food Product	Typical Production for Model BR16-FR45	Typical Production for Model BR20-FR65
Potatoes — Raw to Finished	100-105 lbs. per hour	115-120 lbs. per hour
— Blanched to Finished	320-325 lbs. per hour	355-360 lbs. per hour
Chicken — Raw to Finished	50-55 lbs. per hour	55-60 lbs. per hour
— Blanched to Finished	95-100 lbs. per hour	105-110 lbs. per hour

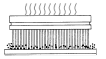

CLEANING

Blodgett Range equipment is constructed with the best quality materials and is designed to provide durable service when properly maintained. To expect the best performance, your equipment must be maintained in good condition and cleaned daily. Naturally, the frequency and extent of cleaning depends on the amount and degree of usage.

Following daily and more extensive periodic maintenance procedures will increase the life of your equipment. Climatic conditions (e.g., salt air) may result in the need for more thorough and more frequent cleaning in order to keep equipment performing at optimal levels.



WARNING: BURN HAZARD

If necessary to move the fryer for cleaning, etc., drain oil first to avoid death or serious injury.

NOTICE

Adequate restraining means must be attached to rear of appliance when installed. Installation must conform to local codes as applicable.



WARNING

If disconnection of the restraint is necessary to move the appliance for cleaning, etc., reconnect it when the appliance is moved to its originally installed position.



WARNING

For an appliance equipped with casters, the installation shall be made with a connector that complies with the Standard for *Connectors for Movable Gas Appliances, ANSI Z21.69* or *Connectors for Moveable Gas Appliances, CAN/CGA-6.16*, and a quick-disconnect device that complies with the Standard for *Quick-Disconnect Devices for Use With Gas Fuel, ANSI Z21.41*, or *Quick Disconnect Devices for Use with Gas Fuel, CAN1-6.9*. Adequate means must be provided to limit the movement of the appliance without depending on the connector and the quick-disconnect device or its associated piping to limit the appliance movement.

CLEANING

DAILY CLEANING

1. Turn combination gas valve knob to "PILOT" position.
2. Place suitable container under the drain and drain the frypot completely.
3. Remove the basket support frame and flush out any sediment remaining in the frypot with a little hot oil.
4. Wipe off the basket support frame and the inside of the frypot with a clean cloth.



CAUTION

SOME AREAS OF THE FRYPOT MAY BE HOT!



5. Close drain valve and strain the oil back into the frypot through several thicknesses of cheesecloth, or filter it back using a filter machine.
6. Replace the basket support frame.
7. Add oil or solid shortening to raise oil level to mark on rear of frypot.
8. To resume cooking, turn the combination gas valve knob to "ON" position.

WEEKLY CLEANING

1. Follow steps 1 through 4 of the Daily Cleaning procedure (see previous section).
2. Close drain valve and fill frypot with a solution of warm water and a strong detergent or other strong cleanser.
3. Relight the fryer and bring the solution to a gentle boil for at least five minutes.
4. Turn off main burners and let the solution stand until the gum deposits are softened and the carbon spots and burned grease spots can be rubbed off.
5. Scrub the frypot walls and heat tubes, then drain out frypot and rinse it with clean water.
6. Refill the frypot with clean water and boil again.
7. Turn off gas and drain and rinse well until clean.
8. Wipe dry with a clean cloth.
9. Refill as specified in the "Filling the Frypot" section (see page 15).

MONTHLY CLEANING

1. Perform the Weekly Cleaning procedure (see previous section).
2. Clean around burner and orifices if lint has accumulated.
3. Visually check that burner carry-over ports are unobstructed.

SEMIANNUAL CLEANING

1. Examine and clean the venting system.
2. Have your Authorized Service Agent or another qualified service technician clean and adjust the unit for maximum performance. Consult the Authorized Parts/Service Distributor list for the Authorized Service Representative in your area or contact Blodgett Range at 1-800-348-2558.

CLEANING STAINLESS STEEL SURFACES

To remove normal dirt, grease and product residue from stainless steel use ordinary soap and water (with or without detergent) applied with a sponge or cloth. Dry thoroughly with a clean cloth. Never use vinegar or any corrosive cleaner.

To remove grease and food splatter, or condensed vapors, that have baked on the equipment, apply cleanser to a damp cloth or sponge and rub cleanser on the metal in the direction of the polishing lines on the metal. Rubbing cleanser, as gently as possible, in the direction of the polished lines will not mar the finish of the stainless steel. NEVER RUB WITH A CIRCULAR MOTION. Soil and burnt deposits that do not respond to the above procedure can usually be removed by rubbing the surface with SCOTCH-BRITE scouring pads or STAINLESS scouring pads. DO NOT USE ORDINARY STEEL WOOL, as any particles left on the surface will rust and further spoil the appearance of the finish. NEVER USE A WIRE BRUSH, STEEL SCOURING PADS (EXCEPT STAINLESS), SCRAPER, FILE OR OTHER STEEL TOOLS. Surfaces that are marred collect dirt more rapidly and become more difficult to clean. Marring also increases the possibility of corrosive attack. Refinishing may then be required.

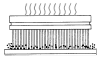

Darkened areas, called “heat tint,” sometimes appear on stainless steel surfaces where the area has been subjected to excessive heat. These darkened areas are caused by thickening of the protective surface of the stainless steel and are not harmful. Heat tint can normally be removed by the above cleaning techniques, but tint which does not respond to that procedure calls for a vigorous scouring in the direction of the polish lines, using SCOTCH-BRITE scouring pads or a STAINLESS scouring pad in combination with a powered cleanser. Heat tint action may be lessened by not applying, or by reducing, heat to equipment during slack periods.



SERVICE

NOTICE

Warranty will be void and the manufacturer is relieved of all liability if:

- (A) Service work is performed by other than a qualified technician,**
- OR**
- (B) Other than genuine factory replacement parts are installed.**

WARNING

Adjustments and service work may be performed only by a qualified technician who is experienced in, and knowledgeable with, the operation of commercial gas cooking equipment. However, to assure your confidence, contact your Authorized Service Agent for reliable service, dependable advice or other assistance, and for genuine factory parts.

WARNING

Appliances equipped with casters have been installed with a restraint to limit their movement to prevent damage to the gas supply connecting system. If disconnection of this restraint is necessary to move the appliance for cleaning, etc., reconnect it when the appliance is moved to its original installed position.

All units are adjusted at the factory. In case of problems in operation at initial installation, check type of gas and manifold pressure and compare with information listed on the serial plate.

A millivoltage circuit diagram is located inside the front door of the fryer, and also on page 26.

CHECKING AND ADJUSTING MAIN BURNERS

The main burners should burn with a steady blue flame, and the inner cone of the flame from each port should be about 3/4" long. The flame from each main burner should enter each heat tube without touching the front of the frypot or the sides, top, or bottom of each tube.

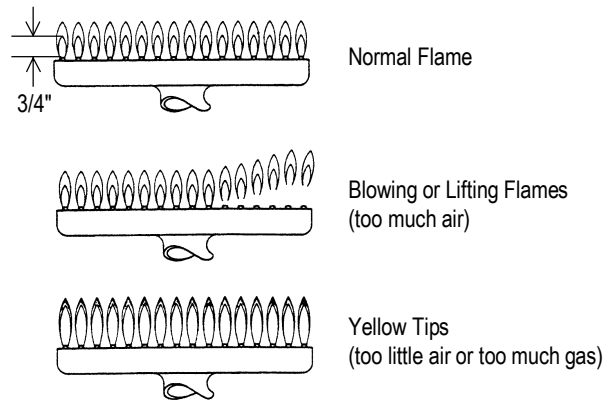

SERVICE

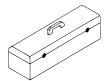

CHECKING AND ADJUSTING PRESSURE REGULATOR

The combination gas valve and pressure regulator is factory set at 4" W.C. for natural gas and 10" W.C. for propane gas. To check the manifold pressure, do the following:

1. Turn thermostat "OFF" (lowest position) and combination gas valve knob to the "PILOT" setting.
2. Remove pressure tap plug from burner manifold located directly below the burners in the cabinet.
3. Install a fitting appropriate to connect a manometer.
4. Turn combination gas valve to "ON" position and thermostat to "ON." The burners will ignite. Be certain that sufficient oil is covering the tubes.
5. With burners on, read manometer.
6. If the manometer does not read 4" W.C. for natural gas, or 10" W.C. for propane gas, adjust regulator.
7. Remove regulator adjustment screw cap (see diagram on page 26).
8. With small screwdriver rotate adjustment screw "CLOCKWISE" to increase or "COUNTERCLOCKWISE" to decrease pressure. Be sure to adjust with burners "ON."
9. Turn thermostat "OFF" and set combination gas valve knob to "PILOT" position.
10. Remove manometer and replace pressure tap plug.
11. Replace adjustment screw cap.

CHECKING AND ADJUSTING CALIBRATION OF THERMOSTAT

All thermostat controls are carefully calibrated at the factory (i.e., the dial is properly set to control appliance temperatures accurately). Only a qualified appliance service technician should perform this adjustment.

1. To check appliance temperatures, use a thermocouple-type temperature test instrument or reliable thermometer. Place the thermocouple of test instrument or thermometer in the center of the frypot.
2. Turn the control dial to the temperature setting requiring the greatest accuracy. Allow enough time for temperature to stabilize, or until several temperature readings are identical.
3. Recalibrate if setting and actual temperature differ by more than 10°F.
4. Remove dial from dial shaft "B." Be careful that dial shaft does not rotate in either direction (which would change the dial setting).
5. Hold dial shaft "B" steady and with a screwdriver turn calibration screw "A" clockwise to decrease the temperature, or counterclockwise to increase the temperature.
6. Replace dial. Let the appliance operate until the temperature has stabilized before a final check is made to determine whether or not the calibration has been corrected.
7. Once correct, seal the calibration screw with glyptol.

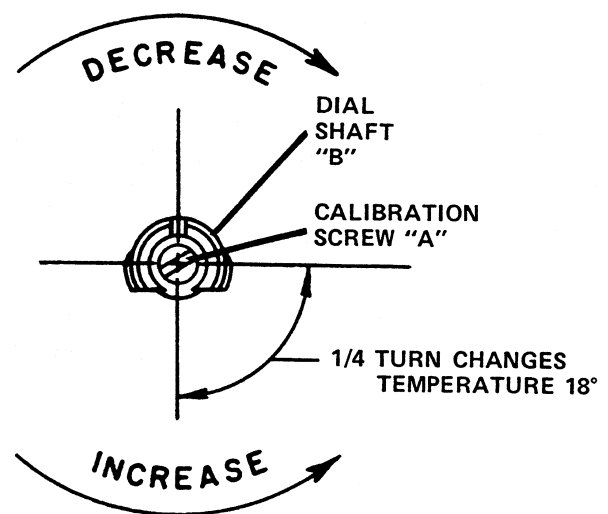

SERVICE



CHECKING AND ADJUSTING AUTO SAFETY PILOT

The pilot flame should surround the thermopile for 1/2". It must be large and sharp enough to cause the thermopile to glow a dull red, or sufficient to hold the safety valve open.

1. Remove pilot adjustment cap (see wiring diagram on page 26 for location).
2. Adjust pilot key to provide properly sized flame.
3. Replace pilot adjustment cap.

CONVERTING FROM NATURAL GAS TO LP GAS

Obtain a natural-to-LP gas conversion kit (Southbend part number 4440499) from your authorized Blodgett Range parts distributor. The kit comes with five LP gas orifice spuds (of which four are used by a model B16-FR45 and five by a model B20-FR65). In the following procedure, refer to the parts diagrams on pages 35 and 37, and the figures below on the right.

1. Turn off gas supply to the fryer.
2. Remove the existing natural gas spud from each burner and replace it with an LP gas spud from the conversion kit.
3. Loosen the compression fitting at the pilot and remove the pilot tubing from the pilot.
4. Remove the two pilot mounting screws.
5. Remove the natural gas pilot orifice from the pilot and replace it with the LP gas pilot orifice from the conversion kit.
6. Remount the pilot assembly, reposition the pilot tubing, and tighten the compression fitting.
7. Partially depress and turn the manual gas control knob on the combination gas valve to "OFF" (see diagram at right).
8. Remove pressure regulator adjustment cap screw and pressure regulating adjustment screw.
9. Remove the existing spring.
10. Insert the replacement spring with the tapered end down.
11. Install new plastic pressure regulating adjustment screw. Ensure that the screw top is flush with the regulator top.
12. Turn the pressure regulator adjustment screw clockwise six complete turns. The preliminary pressure setting will then be approximately 10" W.C. for the LP gas.
13. Turn on the gas supply to the fryer. With the main burners on, test for leaks using a soap solution.
14. Check and adjust the pressure regulator (see procedure on page 23). The pressure should be 10" W.C. for LP gas.
15. Install the new cap screw.

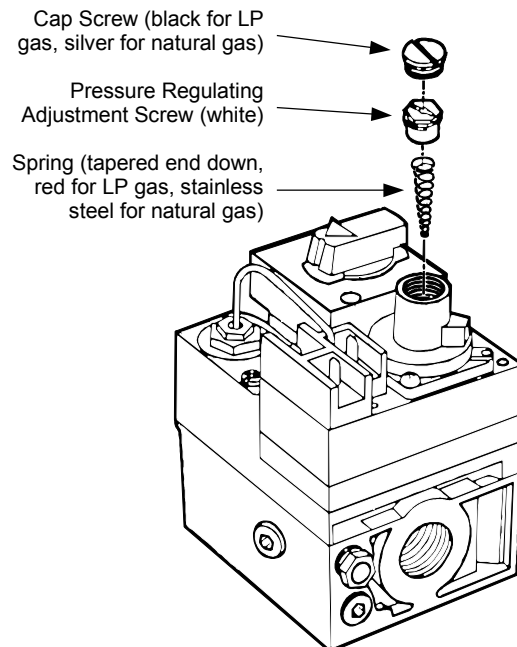
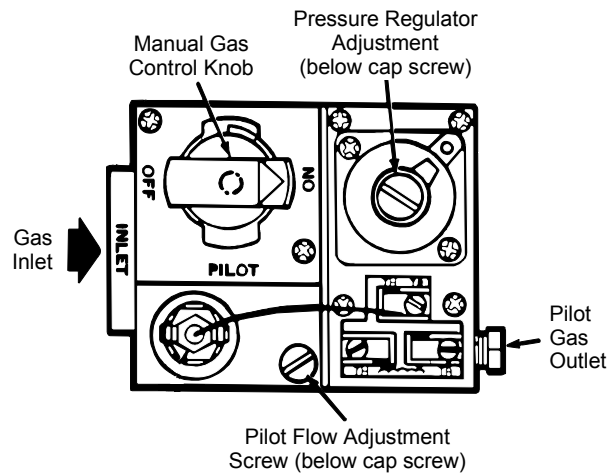

SERVICE

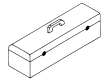

TROUBLESHOOTING

Problem	Likely Cause
Burners do not come on	Gas supply to unit off. Combination gas valve is in "OFF" or "PILOT" position. Pilot not ignited. Thermostat not "ON."
Pilot will not stay ignited	Combination gas valve is in "OFF" position. Pilot gas not adjusted properly. Gas supply to unit off. Bad thermopile. Dirty thermopile connections at combination gas valve or high limit. Bad magnet assembly in combination gas valve. Clogged orifice. Draft condition. Air in gas line. Improper ventilation system. Oil excessively hot.
Pilot produces carbon deposits	Unit connected to wrong gas supply. Pressure not adjusted correctly. Pilot gas not adjusted correctly.
Burners produce carbon deposits	Wrong size orifices. Connected to wrong gas supply. Pressure not adjusted correctly. Flue obstructed.

NOTE: Vibrations or shock caused by shaking or pounding baskets on top surface or by slamming door may cause Hi-Limit Control Switch to open. If this condition persists, additional cushioning may be added to the rubber grommets supporting this control to absorb these shocks.



Wiring Diagram

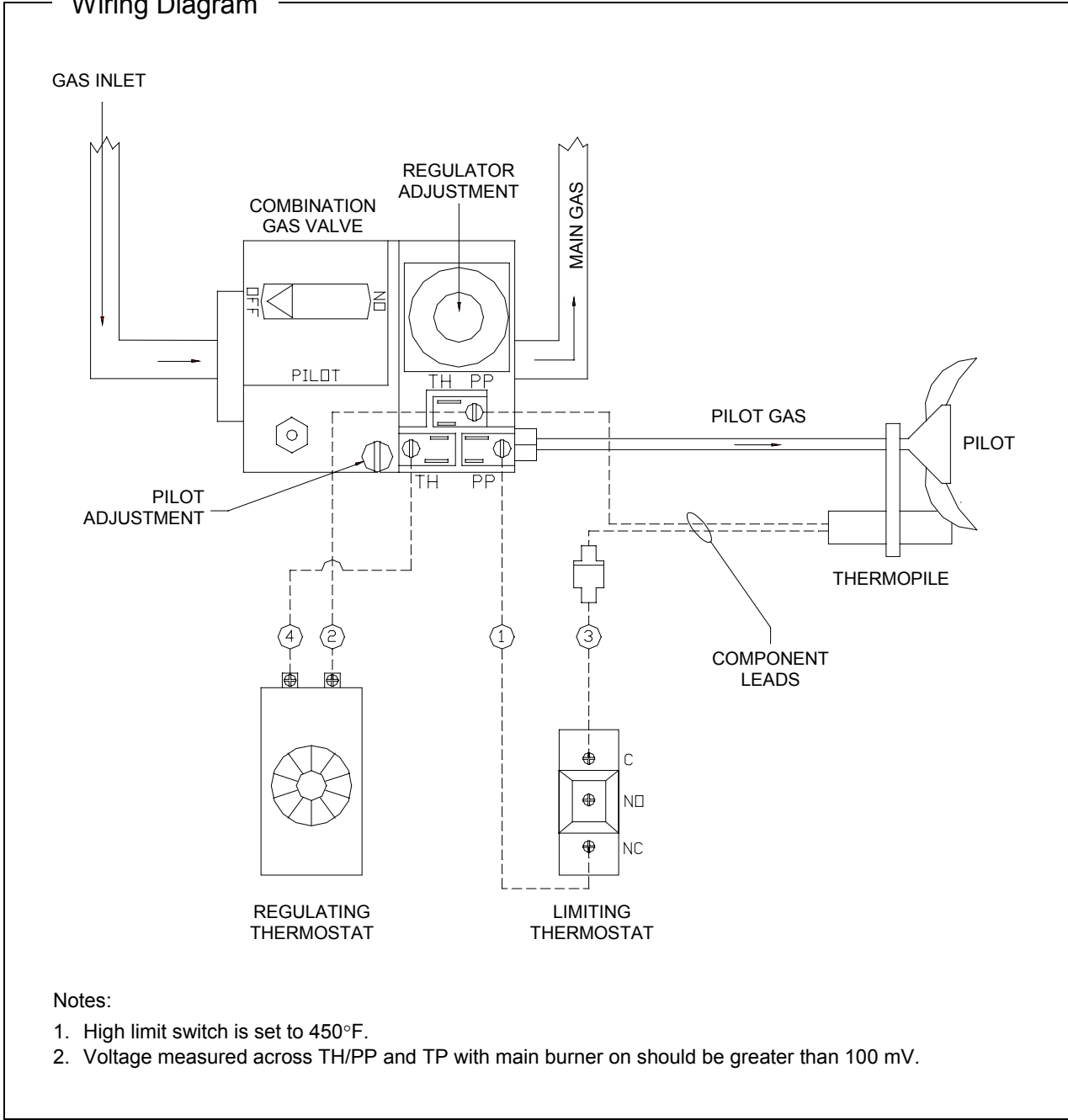

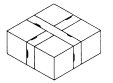

PARTS

NOTICE

INSTALLATION OF OTHER THAN GENUINE FACTORY PARTS WILL VOID THE WARRANTY ON THIS EQUIPMENT.

The serial plate is located inside the front door on the left side.

Replacement parts may be ordered either through an Authorized Parts Distributor or an Authorized Service Agency.

When ordering parts, please supply the Model Number, Serial Number, Part Number, and Description.

For parts not listed, consult an Authorized Parts Distributor or an Authorized Service Agency. Consult the Authorized Parts/Service Distributor list for the Authorized Parts supplier in your area.

Index of Parts Diagrams	
Page Number	Description
28	Frypot Parts for Model B16-FR45
29	Frypot Parts for Model B20-FR65
30	Cabinet Parts for Model B16-FR45
32	Cabinet Parts for Model B20-FR65
34	Gas Train Parts for Model B16-FR45
36	Gas Train Parts for Model B20-FR65

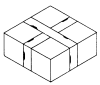

Frypot Parts for Model B16-FR45

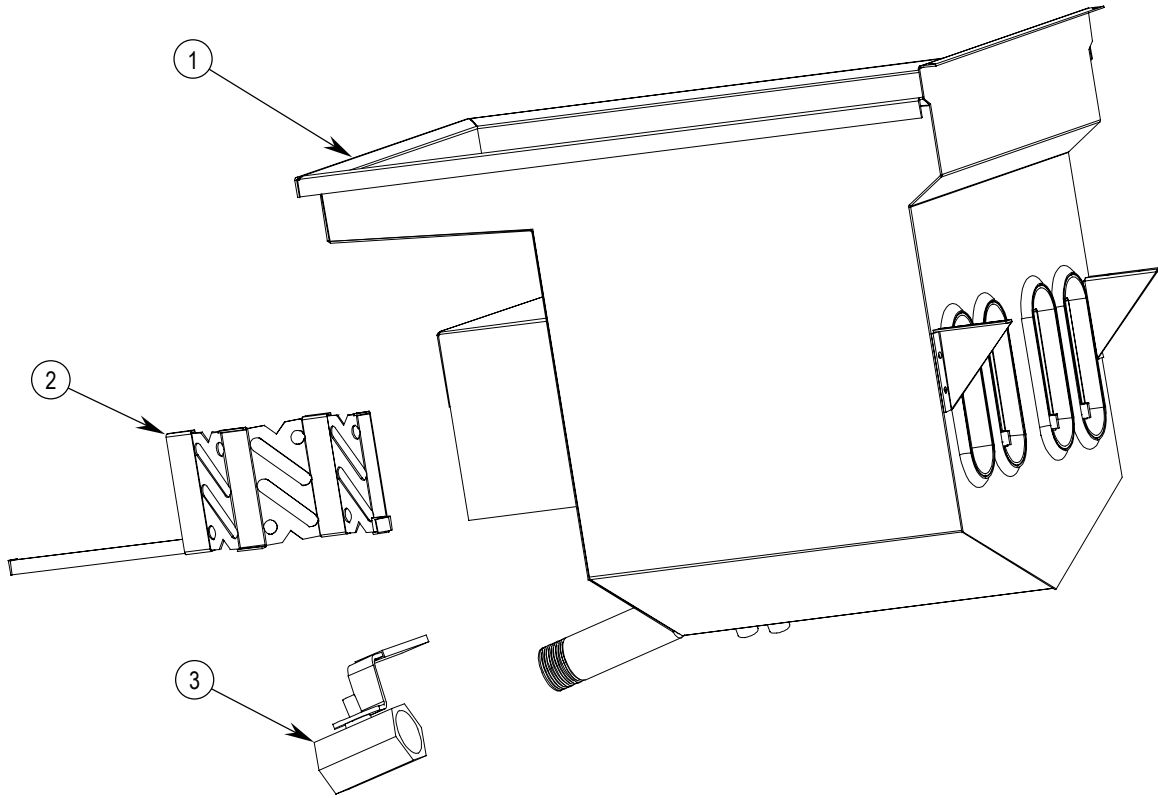

Key	Part Number	Qty	Description
1	1182221	1	Frypot weld assembly
2	1182262	4	Baffle weld assembly
3	1182238	1	Valve, ball, 1-1/4 in
*	1036618	1	Thermostat bulb clamp
*	1140700	1	Screen, tube, 14" fryer
*	P9181	2	Basket, fryer, 14", single
*	1176845	1	Drain pipe extension
*	1176846	1	Clean out rod (optional)

* not shown on drawing.

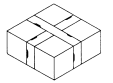

Frypot Parts Model B20-FR65

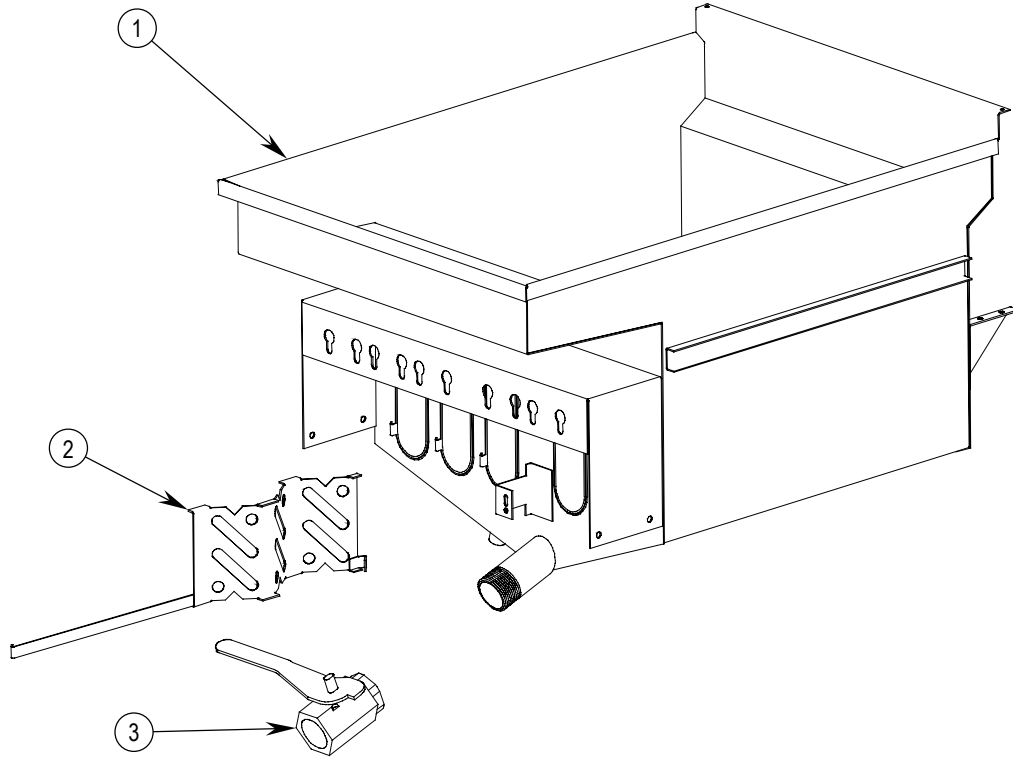

Key	Part Number	Qty	Description
1	1182005	1	Frypot weld assembly
2	1182021	5	Baffle weld assembly
3	1176853	1	Valve, ball
*	1036618	1	Thermostat bulb clamp
*	1140701	1	Screen, tube, 18" fryer
*	P9183	2	Basket, fryer, 18", single
*	1176845	1	Drain pipe extension
*	1176846	1	Clean out rod (optional)
* not shown on drawing.			



Cabinet Parts for Model B16-FR45

See drawing on following page.

Key	Part Number	Qty	Description
2	1-2849	1	Knob, door
3	2391	1	Cabinet door assembly
4	1164132	1	Door striker
5	1164133	1	Catch, door
6	2835	1	Body front
7	1164541	1	Valve panel
8	1182138	1	Manifold assembly, complete
9	1182372	1	Cover subassembly, 16" sectional fryer
10	1182375	1	Filler, rear 45lb
11	1182376	1	Hanger, basket
12	1182355	1	Flue extension, front, sectional fryer
13	1182356	1	Flue extension, rear, sectional fryer
15	1182114	1	Flue box, 36" sectional fryer
	1182113	1	Flue box, 42" sectional fryer
16	1182119	1	Flue bottom, 36" sectional fryer
	1182108	1	Flue bottom, 42" sectional fryer
17	1182118	1	Flue back, 36" sectional fryer
	1182107	1	Flue back, 42" sectional fryer
18	1182117	1	Flue front, 36" sectional fryer
	1182106	1	Flue front, 42" sectional fryer
19	1183704	1	Body side, left
	1183706	1	Body side, left, with fryer filter
20	1183703	1	Body side, right
	1183705	1	Body side, right, with fryer filter
21	1174265	1	Caster, 4-bolt (set of four; two front with brake, two rear without brake)
22	1174260	1	Leg (set of four)
23	1146201	16	Screw, 1/4-20x3/4, hex head
24	1146500	16	Washer, 1/4, lock
25	1172650	1	Pad, leg 3/4 stud (set of four)
*	1182370	1	Filler, 42" flue depth, box top

* not shown on drawing.

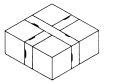

Cabinet Parts for Model B16-FR45

See parts list on previous page.

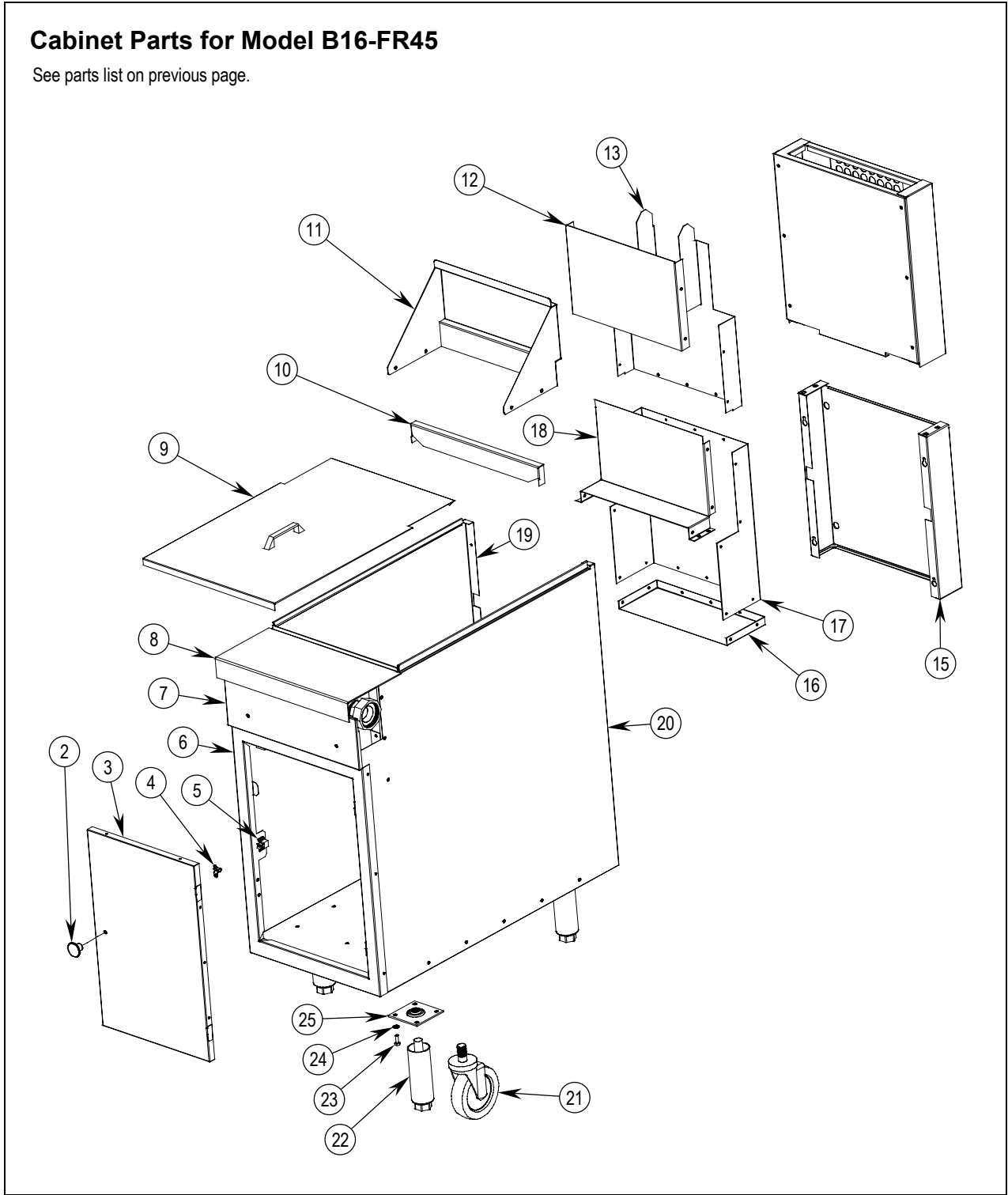



Cabinet Parts for Model B20-FR65

See drawing on following page.

Key	Part Number	Qty	Description
2	1-2849	1	Knob, door
3	1183730	1	Door assembly, complete
4	1164132	1	Door striker
5	1164133	1	Catch, door
6	1183724	1	Body front
7	1183722	1	Valve panel
8	1183709	1	Manifold assembly, complete
9	1183740	1	Cover subassembly, frypot
10	1183761	1	Filler, rear 65lb
11	1183759	1	Hanger, basket
12	1183718	1	Flue extension, front
13	1183719	1	Flue extension, rear
15	1183720	1	Flue box, 36" sectional fryer
	1183721	1	Flue box, 42" sectional fryer
16	1183713	1	Flue bottom, 36" sectional fryer
	1183716	1	Flue bottom, 42" sectional fryer
17	1183712	1	Flue back, 36" sectional fryer
	1183715	1	Flue back, 42" sectional fryer
18	1183714	1	Flue front, 36" sectional fryer
	1183717	1	Flue front, 42" sectional fryer
19	1183704	1	Body side, left
	1183706	1	Body side, left, with fryer filter
20	1183703	1	Body side, right
	1183705	1	Body side, right, with fryer filter
21	1174265	1	Caster, 4-bolt (set of four; two front with brake, two rear without brake)
22	1174260	1	Leg (set of four)
23	1146201	16	Screw, 1/4-20x3/4, hex head
24	1146500	16	Washer, 1/4, lock
25	1172650	1	Pad, leg, 3/4 stud (set of four)
*	1183745	1	Filler, 65lb 42" flue box top
* not shown on drawing.			

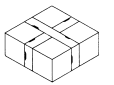

Cabinet Parts for Model B20-FR65

See parts list on previous page.

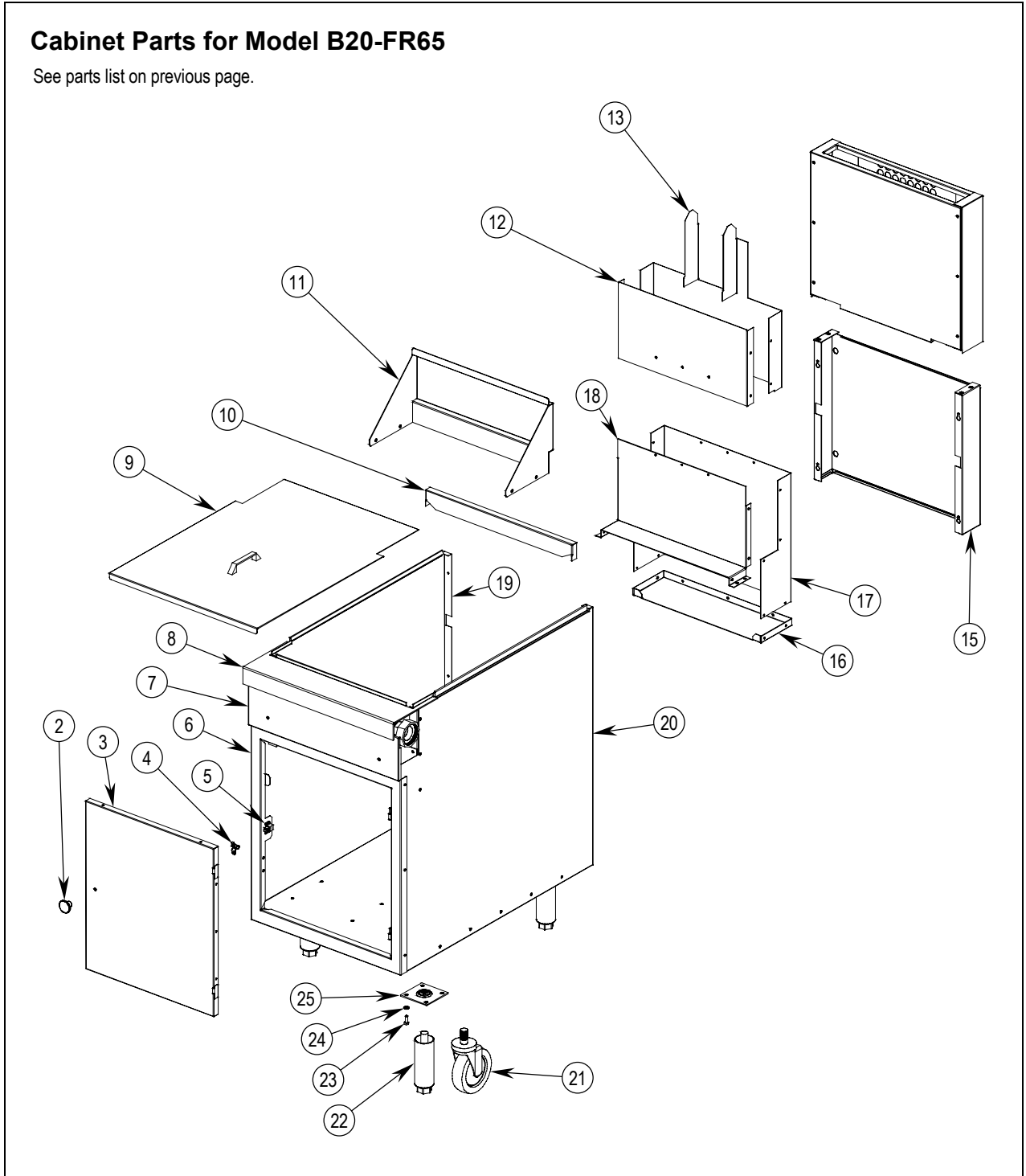

**Gas Train Parts for Model B16-FR45**

See drawing on following page.

Key	Part Number	Qty	Description
1	1165400	1	Rear gas bracket (for units with optional rear gas connection)
2	1163527	1	Tail pipe (for units with optional rear gas connection)
3	1146905	2	Elbow, st. black., 1" 90 deg (for units with optional rear gas connection)
4	1163567	1	RR gas sup vert (for units with optional rear gas connection)
5	1146832	1	Nipple, pipe, blk, 1"x3" (for units with optional rear gas connection)
6	1146911	1	Elbow, st. black., 1" 90 deg (for units with optional rear gas connection)
7	1147012	1	Plug, pipe
9	1160008	1	Elbow, brass
10	1182121	1	Tubing, gas supply
11	1182135	1	Fitting, 1/2 NPT(f) x 5/8 cc, strt, brass
12	1146825	1	Nipple, pipe, blk, 1/2"x3.5"
13	1146909	2	Elbow, st. black., 1/2" 90 Deg
14	1182069	1	Valve, combination, natural gas
	1182103	1	Valve, combination, LP gas
15	1175216	1	Nipple, 1/2 x 4-1/2, black
16	1182237	1	Manifold, 4 burner
17	1147007	1	Plug, pipe black, 1/8
18	1182056	1	Bracket, manifold support (45)
19	1182034	4	Fitting, gas orifice
20	1036604	4	Nut air collar
21	1182040	4	Orifice, main, natural gas (#36)
	1182043	4	Orifice, main, propane (#52)
22	1182155	4	Burner, fryer, 6 inch
23	1146806	1	Nipple, pipe, close, blk, 1/2"
24	P5239-4	1	Union, black, 1/2"
25	1182077	1	Tube, pilot
26	1182154	1	Thermopile
27	1054118	1	Pilot orifice, nat
	1054111	1	Pilot orifice, propane (0.011", orifice only)
28	1054197	1	Pilot assembly, 0.018, natural gas
29	1182116	1	Bracket control
30	1182151	1	Thermostat, regulating
31	1182150	1	Thermostat, limiting
*	4440499	1	Natural to LP gas conversion kit

* not shown on drawing.

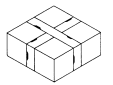

Gas Train Parts for Model B16-FR45

See parts list on previous page.

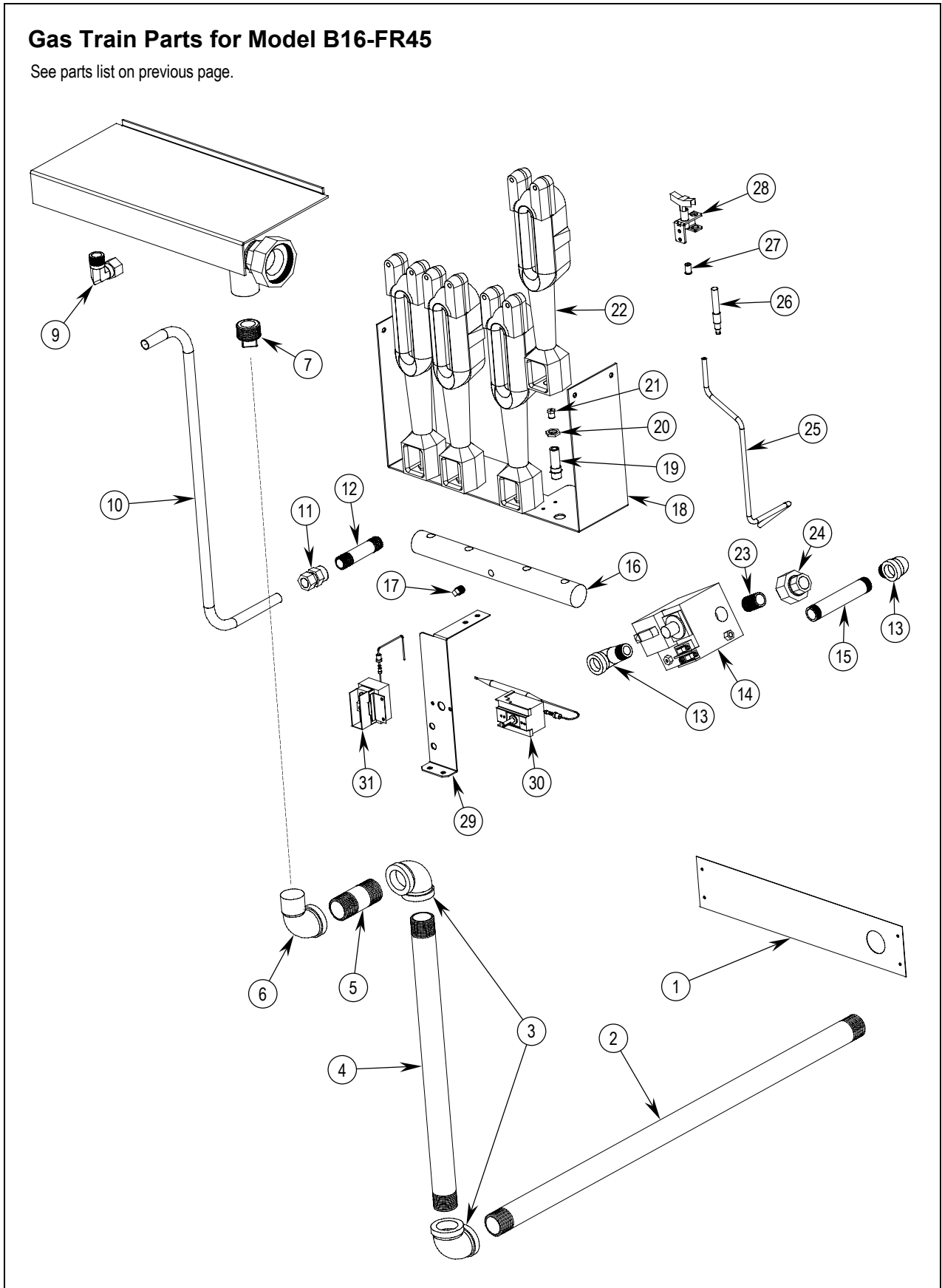

PARTS



Gas Train Parts for Model B20-FR65

See drawing on following page.

Key	Part Number	Qty	Description
1	1183744	1	Support, rear gas (for units with optional rear gas connection)
2	1183743	1	Nipple, pipe, blk 1" x 28" (for units with optional rear gas connection)
3	1146905	2	Elbow, st. black., 1" 90 deg (for units with optional rear gas connection)
4	1183742	1	Nipple, pipe, blk 1" x 15" (for units with optional rear gas connection)
5	1183741	1	Nipple, pipe, blk, 1"x2.5" (for units with optional rear gas connection)
6	1146911	1	Elbow, st. black., 1" 90 deg (for units with optional rear gas connection)
7	1147012	1	Plug, pipe
9	1160008	1	Elbow, brass
10	1183734	1	Tube, supply gas
11	1182135	1	Fitting, 1/2 NPT(f) x 5/8 cc, strt, brass
12	1146825	1	Nipple, pipe, blk, 1/2"x3.5"
13	1146913	1	Elbow, red. black., 3/4 x 1/2, 90 Deg
14	1146806	1	Nipple, pipe, close, blk, 1/2"
15	1182069	1	Valve, combination, natural gas
	1182103	1	Valve, combination, LP gas
16	1175216	1	Nipple, 1/2 x 4-1/2, black
17	1146909	1	Elbow, st., blk, 1/2" 90 deg
18	1182243	1	Manifold 5 burner
19	1147007	1	Plug, pipe black, 1/8"
20	1182057	1	Bracket, manifold support (65)
21	1182034	5	Fitting, gas orifice
22	1036604	5	Nut air collar
23	1182042	5	Orifice, main, natural gas (#38)
	1182043	5	Orifice, main, propane (#52)
24	1182155	5	Burner, fryer, 6 inch
25	P5239-4	1	Union, black, 1/2"
26	1183736	1	Tube, pilot supply
27	1182154	1	Thermopile
28	1054118	1	Pilot orifice, nat
	1054111	1	Pilot orifice, propane (0.011", orifice only)
29	1054197	1	Pilot assembly, 0.018, natural gas
30	1183735	1	Bracket controls support
31	1182151	1	Thermostat, regulating
31	1182150	1	Thermostat, limiting
*	4440499	1	Natural to LP gas conversion kit

* not shown on drawing.

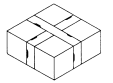

Gas Train Parts for Model B20-FR65

See parts list on previous page.

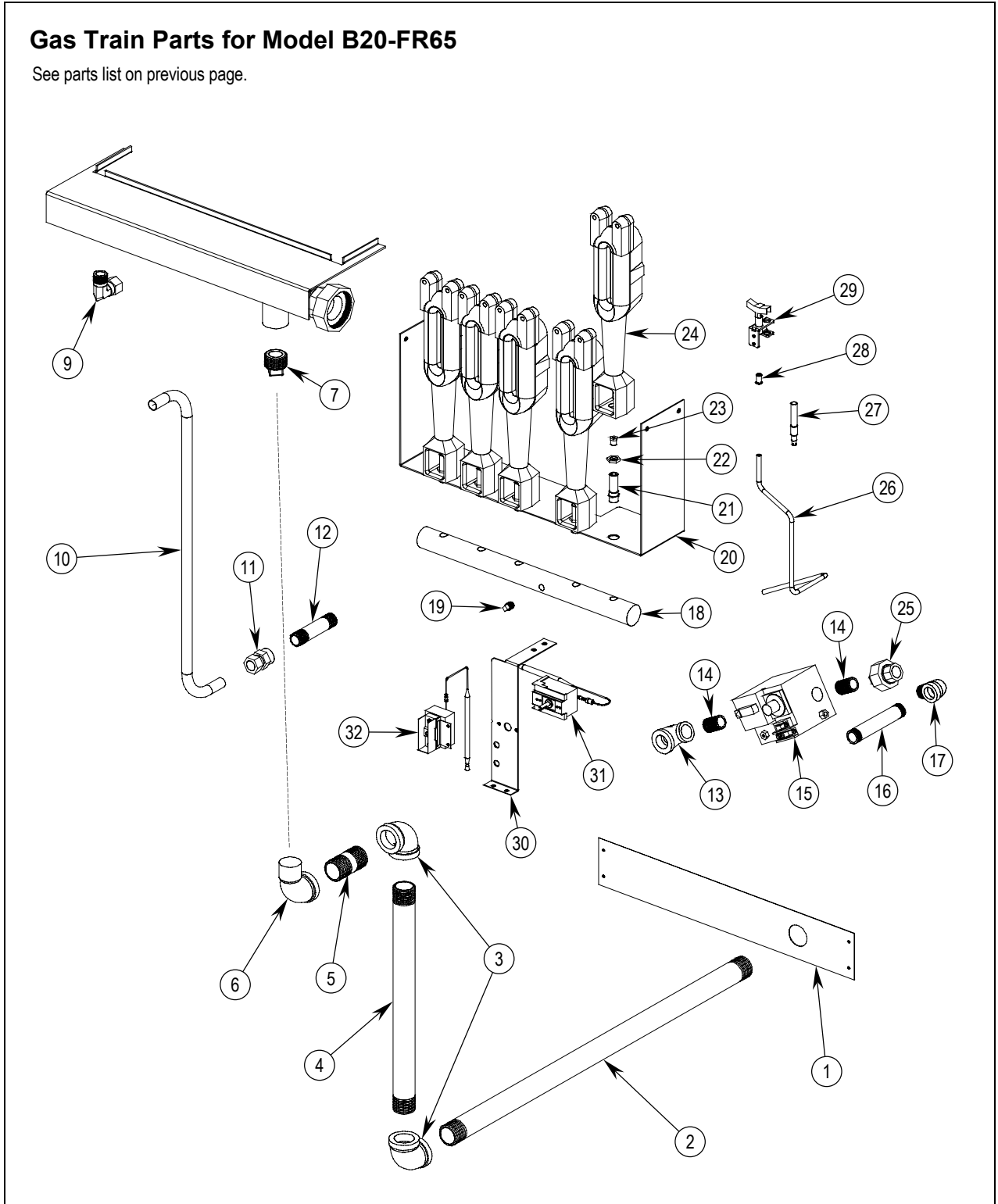

Notes:

SECTIONAL DEEP FRYER

Notes:

Model B16-FR45 and B20-FR65 SECTIONAL DEEP FRYER



A product with the Blodgett Range name incorporates the best in durability and low maintenance. We all recognize, however, that replacement parts and occasional professional service may be necessary to extend the useful life of this unit. When service is needed, contact an Authorized Service Agency or your dealer. To avoid confusion, always refer to the model number, serial number, and type of your unit.



Blodgett Range
1100 Old Honeycutt Road, Fuquay-Varina, NC 27526
www.blodgettrange.com