

# SN-G Series

## GAS ATMOSPHERIC STEAMER

### INSTALLATION - OPERATION - MAINTENANCE



**BLODGETT OVEN COMPANY**

[www.blodgett.com](http://www.blodgett.com)  
44 Lakeside Avenue, Burlington, Vermont 05401 USA  
Manufacture Service Questions: 866-518-3977

PART NUMBER 170148 REV B (04/11)

**THIS MANUAL MUST BE RETAINED FOR FUTURE REFERENCE. READ, UNDERSTAND AND FOLLOW THE INSTRUCTIONS AND WARNINGS CONTAINED IN THIS MANUAL.**

**FOR YOUR SAFETY**

**DO NOT STORE OR USE GASOLINE OR OTHER FLAMMABLE VAPORS AND LIQUIDS IN THE VICINITY OF THIS OR ANY OTHER APPLIANCE.**

**POST IN A PROMINENT LOCATION**

**INSTRUCTIONS TO BE FOLLOWED IN THE EVENT USER SMELLS GAS. THIS INFORMATION SHALL BE OBTAINED BY CONSULTING YOUR LOCAL GAS SUPPLIER. AS A MINIMUM, TURN OFF THE GAS AND CALL YOUR GAS COMPANY AND YOUR AUTHORIZED SERVICE AGENT. EVACUATE ALL PERSONNEL FROM THE AREA.**

**WARNING**

**IMPROPER INSTALLATION, ADJUSTMENT, ALTERATION, SERVICE OR MAINTENANCE CAN CAUSE PROPERTY DAMAGE, INJURY OR DEATH. READ THE INSTALLATION, OPERATING AND MAINTENANCE INSTRUCTIONS THOROUGHLY BEFORE INSTALLING OR SERVICING THIS EQUIPMENT.**

**NOTIFY CARRIER OF DAMAGE AT ONCE**

**IT IS THE RESPONSIBILITY OF THE CONSIGNEE TO INSPECT THE CONTAINER UPON RECEIPT OF SAME AND TO DETERMINE THE POSSIBILITY OF ANY DAMAGE, INCLUDING CONCEALED DAMAGE. WE SUGGEST THAT IF YOU ARE SUSPICIOUS OF DAMAGE TO MAKE A NOTATION ON THE DELIVERY RECEIPT. IT WILL BE THE RESPONSIBILITY OF THE CONSIGNEE TO FILE A CLAIM WITH THE CARRIER. WE RECOMMEND THAT YOU DO SO AT ONCE.**

# IMPORTANT - READ FIRST - IMPORTANT

- WARNING:** THE UNIT MUST BE INSTALLED BY PERSONNEL QUALIFIED TO WORK WITH ELECTRICITY AND PLUMBING. IMPROPER INSTALLATION CAN CAUSE INJURY TO PERSONNEL AND/OR DAMAGE TO THE EQUIPMENT. THE UNIT MUST BE INSTALLED IN ACCORDANCE WITH APPLICABLE CODES.
- CAUTION:** SHIPPING STRAPS ARE UNDER TENSION AND CAN SNAP BACK WHEN CUT.
- CAUTION:** DO NOT INSTALL THE UNIT IN ANY WAY WHICH WILL BLOCK THE SIDE VENTS, OR WITHIN 12 INCHES OF A HEAT SOURCE SUCH AS A BRAISING PAN, DEEP FRYER, CHAR BROILER OR KETTLE.
- CAUTION:** LEVEL THE UNIT FRONT TO BACK, OR PITCH IT SLIGHTLY TO THE REAR, TO AVOID DRAINAGE PROBLEMS.
- WARNING:** FOLLOW THE WIRING DIAGRAM EXACTLY WHEN CONNECTING A UNIT TO AVOID DAMAGE OR INJURY. WIRING DIAGRAM IS LOCATED ON THE INSIDE OF THE RIGHT PANEL.
- CAUTION:** DO NOT USE PLASTIC PIPE. DRAIN MUST BE RATED FOR BOILING WATER.
- WARNING:** DO NOT CONNECT THE DRAIN DIRECTLY TO A BUILDING DRAIN.
- WARNING:** BLOCKING THE DRAIN IS HAZARDOUS.
- IMPORTANT:** IMPROPER DRAIN CONNECTION WILL VOID WARRANTY
- IMPORTANT:** DO NOT ALLOW ANY WATER TRAPS IN THE LINE. A TRAP CAN CAUSE PRESSURE TO BUILD UP INSIDE THE CAVITY DURING STEAMING, WHICH WILL MAKE THE DOOR GASKET LEAK.
- WARNING:** WHEN YOU OPEN THE DOOR, STAY AWAY FROM STEAM COMING OUT OF THE UNIT. STEAM CAN CAUSE BURNS.
- WARNING:** BEFORE CLEANING THE OUTSIDE OF THE STEAMER, DISCONNECT THE ELECTRIC POWER SUPPLY. KEEP WATER AND CLEANING SOLUTIONS OUT OF CONTROLS AND ELECTRICAL COMPONENTS. NEVER HOSE OR STEAM CLEAN ANY PART OF THE UNIT.
- WARNING:** ALLOW COOKING CHAMBER TO COOL BEFORE CLEANING.
- WARNING:** CAREFULLY READ THE WARNINGS AND FOLLOW THE DIRECTIONS ON THE LABEL OF EACH CLEANING AGENT. USE SAFETY GLASSES AND RUBBER GLOVES AS RECOMMENDED BY DELIMING AGENT MANUFACTURER.
- WARNING:** DO NOT MIX DELIMING AGENTS (ACID) AND DE-GREASERS (ALKALI).
- WARNING:** DO NOT PUT HANDS OR TOOLS INTO THE COOKING CHAMBER UNTIL THE FAN HAS STOPPED TURNING.
- WARNING:** DO NOT OPERATE THE UNIT UNLESS THE REMOVABLE RIGHT SIDE PANEL HAS BEEN RETURNED TO ITS PROPER LOCATION.
- NOTICE:** DO NOT USE A CLEANING OR DELIMING AGENT THAT CONTAINS ANY SULFAMIC ACID, OR ANY CHLORIDE, INCLUDING HYDROCHLORIC ACID. IF THE CHLORIDE CONTENT OF ANY PRODUCT IS UNCLEAR, CONSULT THE MANUFACTURER. DO NOT USE A CLEANING OR Deliming AGENT THAT CONTAINS MORE THAN 30% PHOSPHORIC ACID.

# **IMPORTANT - READ FIRST - IMPORTANT**

**NOTICE:** DO NOT USE ANY DE-GREASER THAT CONTAINS POTASSIUM HYDROXIDE OR SODIUM HYDROXIDE OR THAT IS ALKALINE.

**WARNING:** USE OF ANY REPLACEMENT PARTS OTHER THAN THOSE SUPPLIED BY THE MANUFACTURER OR AN AUTHORIZED DISTRIBUTOR VOIDS ALL WARRANTIES AND CAN RESULT IN BODILY INJURY TO THE OPERATOR AND DAMAGE THE EQUIPMENT. SERVICE BY OTHER THAN FACTORY-AUTHORIZED PERSONNEL WILL VOID ALL WARRANTIES.

**WARNING:** HIGH VOLTAGE EXISTS INSIDE CONTROL COMPARTMENTS. DISCONNECT FROM BRANCH CIRCUIT BEFORE SERVICING. FAILURE TO DO SO CAN RESULT IN SERIOUS INJURY OR DEATH.

# Table of Contents

Important Operator Warnings .....	page 1-2
References.....	page 3
Equipment Description .....	page 4
Inspection and Unpacking .....	page 5
Water Quality Management .....	page 6
Installation and Start-Up .....	page 7-9
Initial Start-Up .....	page 10-11
Operation .....	page 12-13
Cleaning .....	page 14-15
Maintenance .....	page 16
Troubleshooting .....	page 17
Parts List - 5G-SN .....	page 18
Parts List - (2) 5G-SN .....	page 19
Electrical Parts List .....	page 20
Parts List .....	page 21
Electrical Schematic .....	page 22
Service Log .....	page 23-24

## References

CSA International  
8501 East Pleasant Valley Road  
Cleveland, OH 44131

NFPA/70 The National Electrical Code

NATIONAL FIRE PROTECTION ASSOCIATION  
60 Batterymarch Park  
Quincy, Massachusetts 02269

NSF INTERNATIONAL  
789 N. Dixboro Road  
P.O. Box 130140  
Ann Arbor, Michigan 48113-0140

KLENZADE SALES CENTER ECOLAB, Inc.  
370 Wabasha  
St. Paul, Minnesota 55102  
800 328-3663 or 612 293-2233

# Equipment Description



The counter-top steamer holds five standard 12" x 20" x 2 1/2" steamer pans.



The stacked steamer holds up to five pans per cavity.

Your 5-Pan Gas Convection Steamer is designed to give years of service. It has a stainless steel cavity (cooking chamber) which is served by an independent atmospheric steam generator which is gas-heated. A powerful blower circulates the steam in the cavity to increase heating efficiency.

Each cavity holds up to five steam table pans (12" x 20" x 2 1/2" deep). An 18 gauge stainless steel case encloses the cavity, the steam generator and the control compartment that houses electrical components. Door hinges are reversible (the door may be set to open from the left or right). Operating Controls are on the front panel.

The steamer is equipped with fully electronic controls and a button-activated, pre-programmed CLEAN cycle. These units are readily identified by their unique control panels. The On-Off switch is operated by touch pad controls, and the distinctive symbol for steam is integrated into the panel.

The drain system on all models includes a spray condenser, which helps keep steam from escaping from the chamber and cools drain water.

BURNING FIRING RATE		
Steamer	Natural Gas at 3.2" W.C.	L.P. Gas at 10.5" W.C.
5G-SN	62,000	62,000
(2) 5G-SN	124,000	124,000

# Inspection & Unpacking

**CAUTION**  
**SHIPPING STRAPS ARE UNDER TENSION**  
**AND CAN SNAP BACK WHEN CUT.**

**CAUTION**  
**THE COUNTER-TOP UNIT WEIGHS 203**  
**POUNDS (92 KG). THE STACKED UNIT**  
**WEIGHS 460 POUNDS (207 KG). YOU**  
**SHOULD GET HELP AS NEEDED TO**  
**LIFT THIS WEIGHT SAFELY.**

The Steamer will be delivered completely assembled in a heavy shipping carton strapped to a skid. On receipt, inspect carton carefully for exterior damage.

Carefully cut the straps and detach the sides of the carton from the skid. Pull the carton up off the unit. Be careful to avoid personal injury or equipment damage from staples which might be left in the carton walls.

Write down the model number, serial number and installation date. Keep this information for reference. Space for these entries is provided at the top of the Service Log in the back of this manual. When starting installation, check packing materials to make sure loose parts such as the condensate drip tray are not discarded with this material.

# Water Quality and Treatment

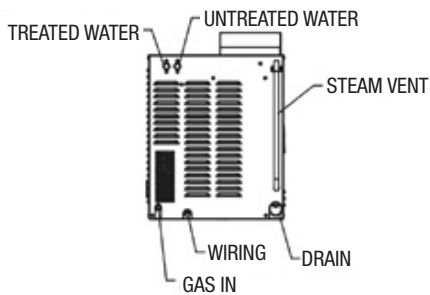

COUNTER-TOP STEAMER

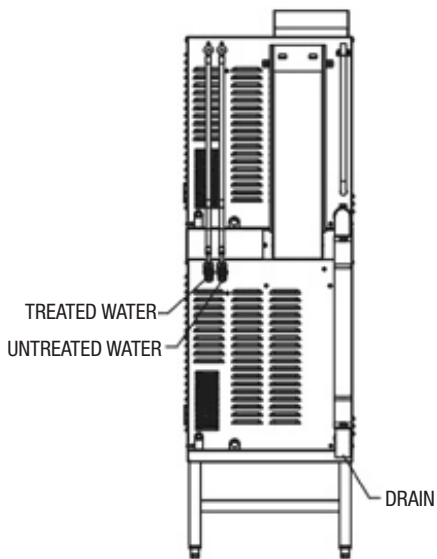

STACKED STEAMER

The second water connection can reduce treated water requirements.

It is essential to supply the steam generator with water that will not form scale. Even though the steam generator/boiler is engineered to minimize scale formation, scale development depends on the hardness of your water and the number of hours you operate the equipment each day.

Most water supplies contain minerals which form scale. It is this scale which could lead to an early component failure.

Your local water utility can tell you about the minerals in your water. The water going to the steam generator should have between 30 and 40 parts per million (ppm) total dissolved solids (TDS) and should have a pH (acidity rating) of 7.0 to 9.0. Please follow these simple precautions:

1. The best way to prevent scale is to use a water treatment system which has been specifically designed for steamers and combination ovens.
2. A well-maintained water treatment system and a regular cartridge replacement schedule is essential.
3. Using a water treatment system will provide longer steam generator/boiler life, higher steam capacity, and reduce maintenance requirements.
4. If you notice a slowdown in steam production or an increase in deliming, have the steamer checked for scale build-up. This could be an indication that the water treatment cartridges need replacing. Heavy scale reduces the unit's ability to boil water, and can even cause component failure.

## **MINIMIZE SCALE PROBLEMS BY INSTALLING AND MAINTAINING WATER TREATMENT SYSTEM AND BY DELIMING THE STEAMER REGULARLY.**

The steamer features two separate water inlets — one for the steam generator/boiler (treated water), the other for the spray condenser (untreated water). The second intake will reduce treatment requirements resulting in significant savings.

The dual water connections are side by side on the rear of the unit. When seen from the back of the unit, the treated water intake is on the left.



# Installation and Start-Up

## WARNING

THE UNIT MUST BE INSTALLED BY PERSONNEL WHO ARE QUALIFIED TO WORK WITH GAS, ELECTRICITY AND PLUMBING. IMPROPER INSTALLATION CAN CAUSE INJURY TO PERSONNEL AND/OR DAMAGE TO THE EQUIPMENT. THE UNIT MUST BE INSTALLED IN ACCORDANCE WITH APPLICABLE CODES.

## CAUTION

DO NOT INSTALL THE UNIT WITH THE RIGHT OR LEFT SIDE VENTS BLOCKED OR WITHIN 12 INCHES OF A HEAT SOURCE (SUCH AS A BRAISING PAN, DEEP FAT FRYER, CHARBROILER OR KETTLE).

TO AVOID DRAINAGE PROBLEMS, LEVEL THE UNIT FRONT TO BACK, OR PITCH IT SLIGHTLY TO THE REAR.

## A. Installation

The counter-top steamer is suitable for installation on or near both combustible and noncombustible surfaces. **Minimum** installation clearances are:

Right Side	2 inches
Left Side	2 inches
Rear	6 inches

However, for easy service at least **12 inches** clearance is required for the **right** side of the unit, and it may **not be installed within 12 inches of a heat source**, as stated in the Caution above.

The unit must be installed in a well-ventilated room with an adequate air supply. The steamer must be installed beneath a ventilation hood, since gas combustion products exit the appliance.

Any item which might obstruct or restrict the flow of air for combustion and ventilation must be removed. Do not obstruct the flue cover or any front, side, rear, or top vents after installation.

The area directly around the appliance must be cleared of all combustible material. The installation must conform with local codes or, in the absence of local codes, with the National Fuel Gas Code, ANSI Z223.1, latest edition, including the following:

The unit and its individual shutoff valve must be **disconnected** from the gas supply system during any pressure testing of that system at test pressures **in excess of** 1/2 PSI (3.45 kPa). It must be **isolated** from the gas supply piping system by closing its individual manual shutoff valve during any pressure testing of the gas supply piping system at test pressures **equal to or less than** 1/2 PSI (3.45 kPa).

### 1. Electrical Supply Connection

Provide 115 VAC, 60 HZ, 1 PH, 15 AMP service. Bring wire in through hole on the lower left back panel. Each cavity requires a separate cord for connections. Local codes and/or the National Electrical Code should be observed in accordance with ANSI/NFPA 70-1987 (or latest edition). **AN ELECTRICAL GROUND IS REQUIRED.** The electrical schematic is located in the service compartment and in this manual. Maximum load is 21/2 AMPS. In Canada, provide electrical service in accordance with the Canadian Electrical Code, CSA C22.1 Part 1 and/or local codes.

# Installation and Start-Up

**WARNING**  
DO NOT CONNECT THE DRAIN DIRECTLY TO A BUILDING DRAIN. BLOCKING THE DRAIN IS HAZARDOUS.

**CAUTION**  
DO NOT USE PLASTIC PIPE. DRAIN MUST BE RATED FOR VERY HOT WATER.

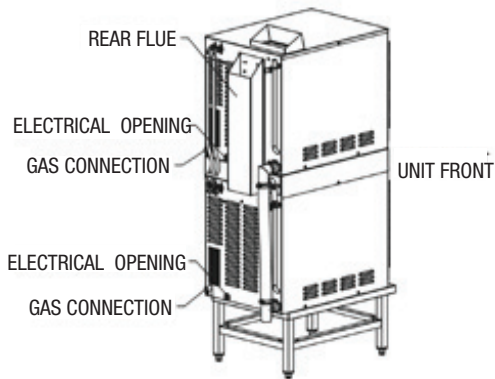

Install the drain line with a constant downward pitch.

**IMPORTANT: Do not allow water traps in the line. A trap can cause pressure build-up in the cavity, which may cause the door gasket to leak.**

## 2. Gas Supply Connection

Connection to the gas supply can be completed with 1/2" NPT pipe or approved equivalent. Although the immediate connection to the appliance is 1/2" NPT, gas supply piping must be large enough to provide 62,000 BTU/hr/cavity. Supply pressure must be at least 4.5" W.C. (maximum 14" W.C.) for natural gas or 12" W.C. (maximum 14" W.C.) for LP gas. In Canada, the installation must conform to the Canadian Gas Code, CAN 1-B149, Installation Codes for Gas Burning Appliances and Equipment and/or local codes. Check all gas connections for leaks prior to unit operation.

After the unit has been connected to the gas supply, all gas joints must be checked for leaks. No flame should be used when checking for leaks. A thick soap solution or other suitable leak detector should be used.

For a unit on casters, complete connection to the gas supply with connectors that comply with the standard for connectors for moveable gas appliances, ANSI Z21.69 — latest edition. Restrain movement of the unit by attaching a cable or chain to the eyelet (provided at the back of the frame) and anchoring the cable or chain to the wall or floor. Make the length and location of the cable such that the unit cannot pull on the gas connection while the cable is connected.

## 3. Water Connection(s)

Install a check valve to prevent back flow in the incoming cold water line, as required by local plumbing codes. Water pressure in the line should be between 30 and 60 PSIG and must deliver a flow rate of 1.5 to 3.0 gallons per minute. If pressure is above 60 PSIG, a pressure regulator will be needed.

3/4 inch female NH connectors (garden hose type) are used to attach the water supply to the inlet valves. One connector is for the steam generator (treated), the other is for the spray condenser (untreated). **Minimum inside diameter of the water feed line is 1/2 inch.** Use a washer in the hose connection. Do not allow the connection to leak, no matter how slowly. Do not over tighten hose connections. Treated (softened) water goes to the right (seen from the rear of the unit), and untreated water to the left. Connections for both are made as shown on Page 7. Though not recommended, an adapter to use a single water intake is available.

## 4. Drain Connection

Level the steamer front to back, or pitch it slightly to the rear (maximum 1/4 inch) by adjusting the optional legs or bullet feet on optional stand. A 2 inch ID hose may be attached to the drain pipe (supplied). There must be a free air gap between the end of the hose and the building drain. The free air gap should be as close as possible to the unit drain. There must also be no other elbows or other restrictions between the unit drain and the free air gap.

# Installation and Start-Up

**WARNING**  
DO NOT CONNECT THE DRAIN DIRECTLY TO A BUILDING DRAIN. BLOCKING THE DRAIN IS HAZARDOUS.

**CAUTION**  
DO NOT USE PLASTIC PIPE. DRAIN MUST BE RATED FOR VERY HOT WATER.

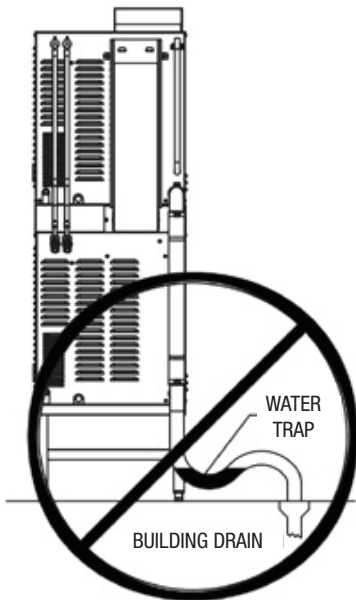

IMPROPER DRAIN LINE CONNECTION

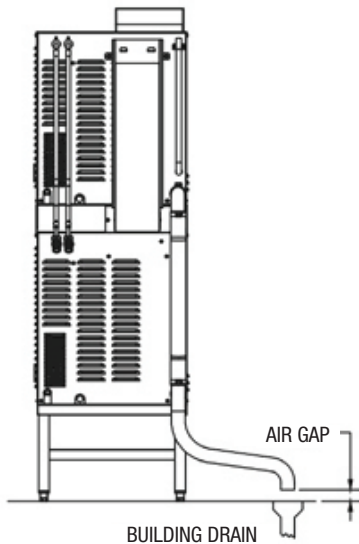

PROPER DRAIN LINE CONNECTION

**Proper Drain Line Connection:**  
Drain line must have a constant downward pitch of at least 1/4" per foot.

## 5. Factory Stacked Units

This section is applicable only if you are installing factory-stacked units.

Installing stacked steamers is similar to installing a single unit. The steamers are stacked and assembled at the factory and delivered with the water connections and drain hoses required for a single point connection.

### a. Water Connection

The same water supply connection is used for both units. At the water inlet valves, 3/4 inch female NH connectors (garden hose type) are used for the water supplies. There are two connections to be made. Treated water (softened) is connected to the right valve fitting (looking from the rear of the unit) and untreated water to the left fitting.

### b. Electrical Supply Connection

Separate, individual electrical connections will be required for each steamer in the stack. Each Steamer must have its own branch circuit protection.

### c. Gas Connection

Separate gas connections are required for each steamer in the stack. Gas supply must be adequate under all conditions as listed on page 9.

### d. Drain Connection

Steamers must be leveled front to back, or pitched to the rear (maximum 1/4 inch) by adjusting the bullet feet on the stand. A 2 inch ID hose may be attached to the unit drain. It must be rated for very hot water.

Ensure that there is a free air gap between the end of the unit drain and the building drain. This gap should be as close as possible to the unit drain. Do not allow elbows or restrictions between the unit and the free air gap.

Install the line with a constant downward pitch.

# Initial Start-Up

**WARNING**  
WHEN YOU OPEN THE DOOR, STAY AWAY  
FROM STEAM COMING OUT OF THE UNIT.  
THE STEAM CAN CAUSE BURNS.



After the steamer has been installed, test it to ensure that the unit is operating correctly.

1. Remove all literature and packing materials from the interior and exterior of the unit.
2. Make sure the water supply line is open.
3. Make sure that the gas supply line is open and that the manual knob on the main gas valve is turned to the “on” position. This valve is located behind the front access panel on the right side of the unit.
4. Turn on electrical service to the unit. The unit will not operate without electrical power. Do not attempt to operate the unit during a power failure.
5. The steamer will not operate until the pilot burner has been ignited. To light the pilot burner, activate the pilot switch located behind the sliding door located on the right cover panel. When the pilot ignition sequence has been successfully completed, a green light - on the pilot switch will glow.
6. The “trial for ignition” period is roughly 90 seconds. If the pilot burner does not light within about 90 seconds after the switch is activated, the ignition system automatically stops gas flow to the pilot burner and stops the ignition trial. If this happens, turn off the pilot switch and repeat the trial for ignition. During the initial start-up, the pilot may require several trials for ignition until all the air is bled from the gas piping. Subsequent start-ups should require only about 5 seconds to achieve pilot ignition.

**NOTE:** See Automatic Operation of Pilot at the end of this section.

7. Once the pilot burner flame has been established (the green light on the pilot switch is on), press the “ON” switch for the desired steamer cavity. The steam generator will fill with water.

**NOTE:** The door **MUST** be closed for the main (high) burner to work.

8. When the steam generator has filled with water, the low and main burners will ignite automatically. Within 8-10 minutes the READY light will come on, indicating that the water has reached its standby temperature. When the READY light is displayed, you may take any one of the following steps:
  - a. Set the timer to the desired time for timed steaming.
  - b. Turn the timer knob to the manual ON position for continuous steam.
  - c. Let the unit stay at standby temperature.

# Initial Start-Up

9. To shut down the unit, press the ON switch into the off position. The steam generator will then drain. You may also switch off the pilot switch to conserve energy.
10. If the steamer behaves as described, the unit is functioning correctly and ready for use.

## **Automatic Operation of Pilot**

Once the pilot burner is lit, it essentially functions as a standing pilot. In this state, if the pilot is accidentally extinguished (by a very strong gust of wind for example), it will re-ignite automatically. The unit will completely shut down for a few seconds while the pilot is re-ignited. Then the unit will come back on and resume operation in the mode and with the (running) timer value existing just prior to shutdown. The pilot switch may be turned off during “off hours” to conserve energy.

After the unit has been running, if the pilot burner ever fails to re-ignite automatically within 90 seconds, wait 5 minutes before you attempt to reactivate it. In the unlikely event that ignition problems persist, contact your authorized Service Agency.

**NOTE:** For operation at high altitudes (2000 feet and above) please consult the Engineering Department.

# Operation

**WARNING**  
ANY POTENTIAL USER OF THE EQUIPMENT  
MUST BE TRAINED IN SAFE AND CORRECT  
OPERATING PROCEDURES.

## A. Controls

Operator controls are on the front right of the unit.

The steamer control panel has the following touch pads and indicator lights:

1. The ON/OFF touch pad gets the steamer ready for use, or shuts it off.
2. The READY indicator light shows that the steam generator is at standby temperature and the cavity is hot enough to begin steaming.
3. The CLEANING indicator light is lit when the unit is operating in the cleaning mode.
4. The SERVICE indicator light shows when the water level probes have stopped working, and need to be cleaned (normally an indication of lime deposits).

*When one probe fails, the SERVICE light flashes briefly every few seconds, but the unit will continue to operate. Delime the unit as soon as possible.*

*If the problem continues, both probes may fail. Then the steamer stops working, the light will flash repeatedly and the beeper will sound. **At this point you must turn off the power and contact an Authorized Service Representative for repair.***

5. The HI TEMP indicator light comes on when the steam generator is too hot.

*The unit will automatically shut off, and cannot be turned on again until the steam generator cools and the HI TEMP indicator light goes out.*

6. The TIMING indicator light stays on when the timer is running.
7. The CLEAN touch pad is used to start the automatic 50 minute cleaning cycle.

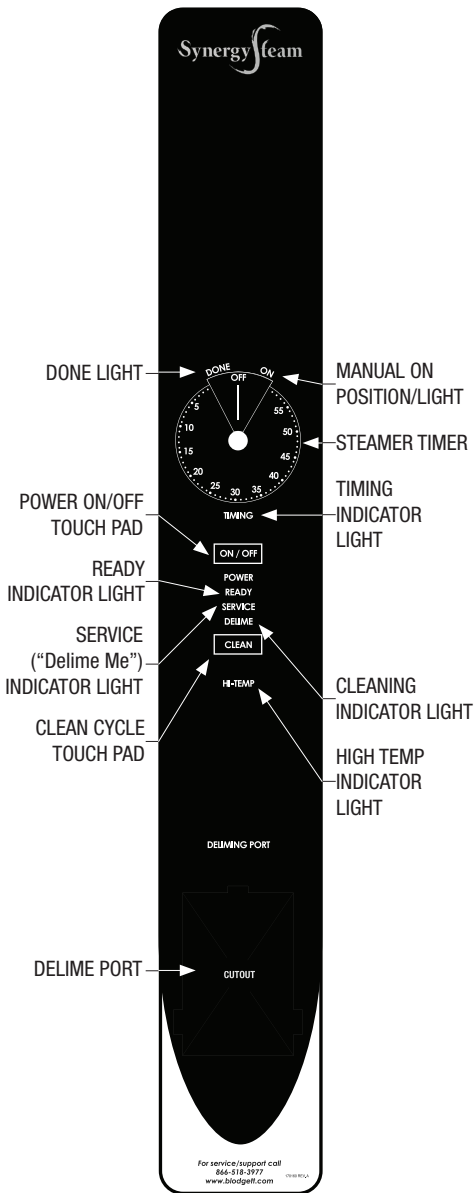

# Operation

**WARNING**  
**WHEN YOU OPEN THE DOOR, STAY AWAY**  
**FROM THE STEAM COMING OUT OF THE**  
**UNIT. THE STEAM CAN CAUSE BURNS.**



The timer is used in three ways:

1. In the OFF position the steam generator stays at a low boil or “holding” temperature.
2. When a cook time is set, the unit steams until the timer runs down to OFF. At that time steaming stops, a red light comes on and a beeper sounds.
3. With the timer turned to the ON position, the unit steams continuously. The green light stays lit. The steamer will **not** time down.

## **B. Operating Procedure**

1. Press the ON/OFF touch pad for the steamer. The steam generator will fill, and heat until the READY light comes on. (About 8-10 minutes.)
2. Load food into pans in uniform layers. Pans should be filled to about the same levels, and should be even on top.
3. Open the door and slide the pans onto the supports. If you will only be steaming one pan, put it in the middle position.
4. Close the door. With the READY indicator lit, take one of the following steps:
  - a. If you want to steam the food for a certain length of time, set the timer for that period. The timer will automatically run the steamer for the set time and then turn it off. A red light will come on and a beeper will sound. Steam production stops.
  - b. If you want to steam continuously, turn the timer to the manual ON position. A green light will come on. The unit will continue steaming until you stop it by turning the timer to OFF. When steaming continuously **YOU MUST CONTROL STEAMING TIME.**
5. Open the door. Remove the pans from the steamer, using hot pads or oven mitts to protect your hands from the hot pans.
6. To shut down the unit, press the ON/OFF touch pad to OFF. The steam generator will automatically drain.

# Cleaning

**WARNING**  
DISCONNECT THE POWER SUPPLY  
BEFORE CLEANING THE  
OUTSIDE OF THE STEAMER.

KEEP WATER AND CLEANING SOLUTIONS  
OUT OF CONTROLS AND ELECTRICAL  
COMPONENTS. NEVER HOSE OR STEAM  
CLEAN ANY PART OF THE UNIT.

DON'T MIX DE-LIMING AGENTS (ACID)  
WITH DE-GREASERS (ALKALI)  
ANYWHERE IN THE UNIT.

AVOID CONTACT WITH ANY CLEANERS,  
DE-LIMING AGENT OR DE- GREASER AS  
RECOMMENDED BY THE SUPPLIER. MANY  
ARE HARMFUL. READ THE WARNINGS AND  
FOLLOW THE DIRECTIONS!

EVEN WHEN THE UNIT HAS BEEN SHUT  
OFF, DON'T PUT HANDS OR TOOLS INTO  
THE COOKING CHAMBER UNTIL THE FAN  
HAS STOPPED TURNING.

DON'T OPERATE THE UNIT UNLESS THE  
REMOVABLE PARTITION HAS BEEN PUT  
BACK IN ITS PROPER LOCATION.

DON'T USE ANY CLEANING OR DE- LIMING  
AGENT THAT CONTAINS ANY SULFAMIC  
AGENT, OR ANY CHLORIDE, INCLUDING  
HYDROCHLORIC ACID (HCl). TO  
CHECK FOR CHLORIDE CONTENT  
SEE ANY MATERIAL SAFETY DATA SHEETS  
PROVIDED BY THE CLEANING AGENT  
MANUFACTURER. DON'T USE ANY  
CLEANING OR DE- LIMING AGENT  
THAT CONTAINS MORE THAN  
30% PHOSPHORIC ACID.

To keep your steamer in proper working condition, use the following procedure to clean the unit. This regular cleaning will reduce the effort required to clean the steam generator and cavity.

## A. Suggested Tools

1. Mild detergent
2. Stainless steel exterior cleaner such as Zepper®
3. Steam generator de-liming agent. A liquid de-liming agent will be easier to use than crystals or powders. See the warning about chlorides, below
4. De-greaser, such as EncompasS®, Malone 34®, Puritan Puribrute®, or Con-Lie®
5. Cloth or sponge
6. Plastic wool or a brush with soft bristles
7. Spray bottle
8. Measuring cup
9. Nylon pad
10. Towels
11. Plastic disposable gloves
12. Funnel

## B. Procedure

1. Exterior Cleaning
  - a. Prepare a warm solution of the mild detergent as instructed by the supplier. Wet a cloth with this solution and wring it out. Use the moist cloth to clean the outside of the unit. Do not allow freely running liquid to touch the controls, the control panel, any electrical part, or any louver on the side or rear panels.
  - b. To remove material which may be stuck to the unit, use plastic wool, a fiber brush, or a plastic or rubber scraper with a detergent solution.
  - c. Stainless steel surfaces may be polished with a recognized stainless steel cleaner such as Zepper®.



## IMPORTANT

DO NOT USE ANY METAL MATERIAL (SUCH AS  
METAL SPONGES) OR METAL IMPLEMENTS  
(SUCH AS A SPOON, SCRAPER OR WIRE BRUSH)  
THAT MIGHT SCRATCH ANY STAINLESS STEEL  
SURFACE. SCRATCHES MAKE THE SURFACE  
HARD TO CLEAN AND PROVIDE PLACES FOR  
BACTERIA TO GROW. DO NOT USE STEEL WOOL,  
WHICH MAY LEAVE PARTICLES IMBEDDED  
IN THE SURFACE WHICH COULD EVENTUALLY  
CAUSE CORROSION AND PITTING.



# Cleaning

**WARNING**  
**SHOULD A CLEAN CYCLE BE INTERRUPTED, IT IS POSSIBLE THAT SOME CLEANING SOLUTION IS STILL PRESENT IN THE STEAM GENERATOR. RE-RUN THE CLEAN CYCLE AND CONFIRM THAT THE WATER IS DRAINING.**



## 2. Steam Generator and Cooking Chamber

On a regularly scheduled basis, or if the SERVICE light is on, follow the simple de-liming instructions below. This procedure should be followed for each cavity. **REMEMBER: DON'T ALLOW DE-LIMING AGENTS TO MIX WITH DE-GREASERS.**

- a. Ensure that the unit is turned on.
- b. Set the timer to "OFF".
- c. Using a glove or towel for hand protection, carefully open the deliming port. The port may be hot, and a small amount of pressureless steam may escape as you open the port.
- d. Add two cups of de-liming agent.
- e. Close the deliming port cover.
- f. Holding in the "CLEAN" button, press and release the ON button.
- g. The clean cycle will start, and take approximately 30 minutes.
- h. When the cleaning cycle is complete, the CLEANING light will flash and the unit will beep.
- i. Wipe out the inside of the steamer cavity.
- j. If the steamer is to be used, turn the "ON" switch on. When READY light turns on, the steamer is ready for operation, set the timer to the "ON" position.

### NOTES:

1. If the clean cycle ends abruptly, the CLEANING light will flash five times per second. This indicates that the clean cycle was aborted.
2. In the event of a power outage during a clean cycle, rerun the clean cycle when the power is restored.
3. To abort a clean cycle, turn the "ON" switch off for one second and turn it back on. **REMEMBER, DELIMING AGENT MAY STILL BE PRESENT IN THE STEAM GENERATOR.**

If the SERVICE light is on:

1. Take the actions listed in Troubleshooting Section of this manual. Turn the steamer off for 10 seconds and then re-start.
2. Repeat steam generator cleaning cycle.

# Maintenance

The steamer is designed for minimum maintenance, and no user adjustments should be necessary. Certain parts may need replacement after prolonged use. If there is a need for service, only authorized representatives should perform the work.

**Always** supply water with a low mineral count that meets the standards outlined in the **Water Quality and Treatment** section of this manual.

If steam or condensate is seen leaking from around the door, take the following steps:

1. Check the door gasket. Replace it if it is cracked or split.
2. Inspect the cooking chamber drain to be sure it is not blocked.
3. Adjust the door latch pin to allow for changes that might occur as the gasket ages.
  - a. Loosen the lock nut at the base of the latch pin, then turn the latch pin 1/4 turn clockwise, and tighten the lock nut.
  - b. After adjustment, run the unit to test for further steam leakage.
  - c. If there is still leakage, repeat the adjustment.
  - d. Continue adjusting the pin clockwise until the door fits tightly enough to prevent leakage. The hinge may also be adjusted.

# Troubleshooting

This steamer is designed to operate smoothly and efficiently if properly maintained. However, the following is a list of checks to make in the event of a problem. Wiring diagrams are furnished inside the service panel. If an item on the check list is marked with (x), it means that the work should be done by a factory-authorized service representative.

SYMPTOM	WHO	WHAT TO CHECK (If item is marked X, work should be done by a factory authorized service rep.)
Pilot will not light.	User	a. Are electrical connections made with a ground? b. Is gas supply connection made? c. Is pilot ignition switch on? d. Is gas valve turned on? e. Are building fuses or circuit breakers all right? f. Are there drafts which could blow out the pilot?
	Authorized Service Rep Only	g. Is spark ignition cable connected to module? (X)
Steam generator does not fill with water.	User	a. Is the ON switch depressed? b. Is the water supply connected? c. Is the water turned on? d. Check for low water pressure (less than 30 PSI or 210 kPa). e. Is the screen at the water connection clogged? f. Has the steam generator been delimed?
No steam.	User	a. Is the ON switch depressed? b. Is the water supply connected? c. Is the water turned on? d. Are steamer doors open? e. Is the steamer generator limed up?
Service light comes on after four minutes.	User	a. Is the water supply connected? b. Is the water turned on? c. Has the unit been delimed? (Refer to Cleaning Section)
Excessive steam escaping from rear of unit.	User	a. Is the water spray hose kinked or obstructed?
	Authorized Service Rep Only	b. Is the water spray solenoid connected? (X) c. Is the drain properly vented? (X)

# Parts List - 5G-SN

To order parts, contact your authorized Service Agency. Supply the model designation, serial number, part description, part number, quantity, and when applicable, voltage and phase.

KEY	DESCRIPTION	PART #
1	RIGHT SIDE PANEL	138532
2	DOOR ASSY, COMPLETE	170128
3	DOOR HANDLE	070123
4	DOOR GASKET	125907
5	LEFT PAN RACK	125901
6	BLOWER COVER/RACK (FAN BAFFLE)	125902
7	DOOR LATCH PIN	078914
8	DOOR PIN LOCK NUT	003823
9	LEFT SIDE PANEL	138534
10	TIMER KNOB	123100
11	FRONT PANEL OVERLAY	170160
12	TOP PANEL	138536
13	FUNNEL, DELIME	106624
14	BACK PANEL	138530
15	OPTIONAL TABLE	100913
16	DRIP TRAY	094151
17	TIMER FASTENER NUT	101145
18	DRAIN TUBE	138546
19	WATER VALVE SINGLE	071235
20	WATER VALVE DOUBLE	100934
x	MOTOR SHAFT SEAL	096868
x	OPTIONAL LEGS	041121
x	CAVITY FAN	096790

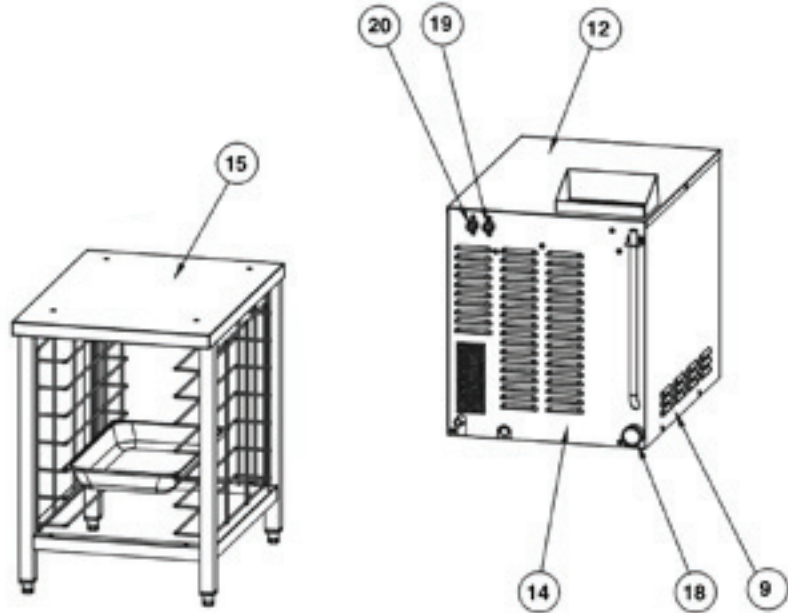
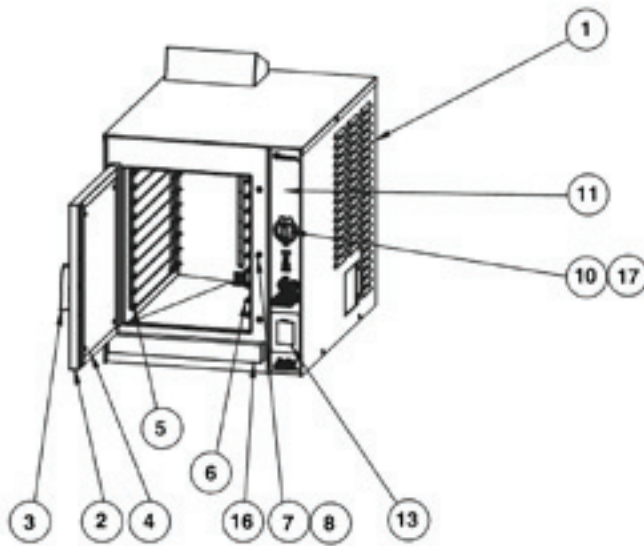

x = Item not depicted/called out in drawings

# Parts List - (2) 5G-SN

To order parts, contact your authorized Service Agency. Supply the model designation, serial number, part description, part number, quantity, and when applicable, voltage and phase.

Parts listed below only apply to a double-stacked unit. Common parts are listed on page 19.

KEY	DESCRIPTION	PART #
1	TABLE	138579
2	SPACER	138594
3	FLUE, INSIDE	138406
4	FLUE, VERTICAL	138401
5	DRAIN AND VENT PIPE	138458
6	HOSE 2" ID X 2" LG	090742
7	CLAMP, HOSE 1-3/4" - 2- 1/2" DIA	015663
8	HOSE VENT	138463
9	DRAIN T-CONNECTOR	126003
10	HOSE DRAIN	138471
11	CLAMP, HOSE 9/16" - 1-1/16" DIA	099284
12	BULLET FOOT	042505
13	WATER HOSE	138470
14	HOSE CONNECTOR	101189

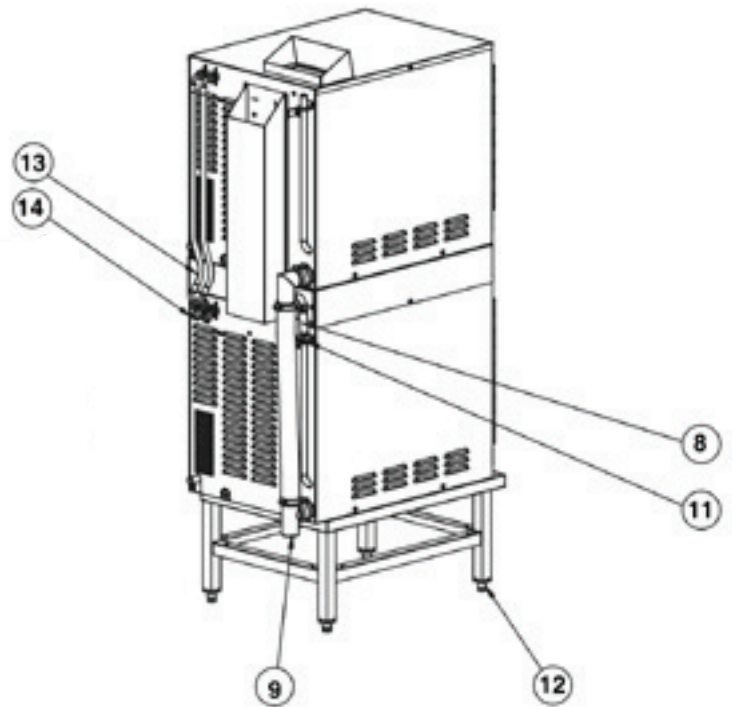
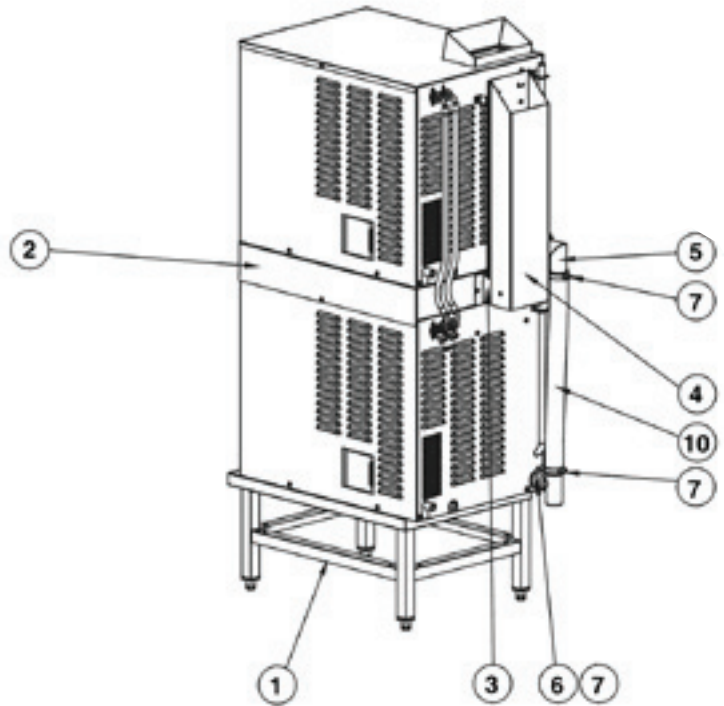

# Electrical Parts List

To order parts, contact your authorized Service Agency. Supply the model designation, serial number, part description, part number, quantity, and when applicable, voltage and phase.

KEY	DESCRIPTION	PART #
1	FUSE, 3 AMP	077853
2	WATER LEVEL PROBES	070178
3	WATER VALVE SINGLE	071235
4	WATER VALVE DOUBLE	100934
5	TRANSFORMER 120V PRIMARY/ 24V SECONDARY 75VA	106233
6	TRANSFORMER 115/230V PRIMARY/ 20VAC CT SECONDARY	119815
7	RELAY, 12VDC	119813
8	RELAY, 24VAC	119814
9	RELAY 24VDC	138420
10	IGNITION MODULE	085153
11	CAPACITOR	096813
12	FUSE HOLDER	077854
13	TERMINAL BLOCK	003887
14	MAIN GAS VALVE	098443
15	GAS VALVE	099906
16	CONTROL BOARD	119801
17	TIMER BOARD	119817
18	DRAIN VALVE	074594
19	READY THERMOSTAT	099947
20	MOTOR ASSY	146880
21	OVERTEMP SENSOR	096892
22	TIMER	096826
23	PILOT SWITCH	087951
24	DOOR SWITCH	096857
X	HARNESS, POWER	130397
X	HARNESS, CONTROL	130399
X	HARNESS, DRAIN	130398
X	HARNESS, TRANSFORMER	119871
X	HARNESS, DOOR + SWITCH	119878

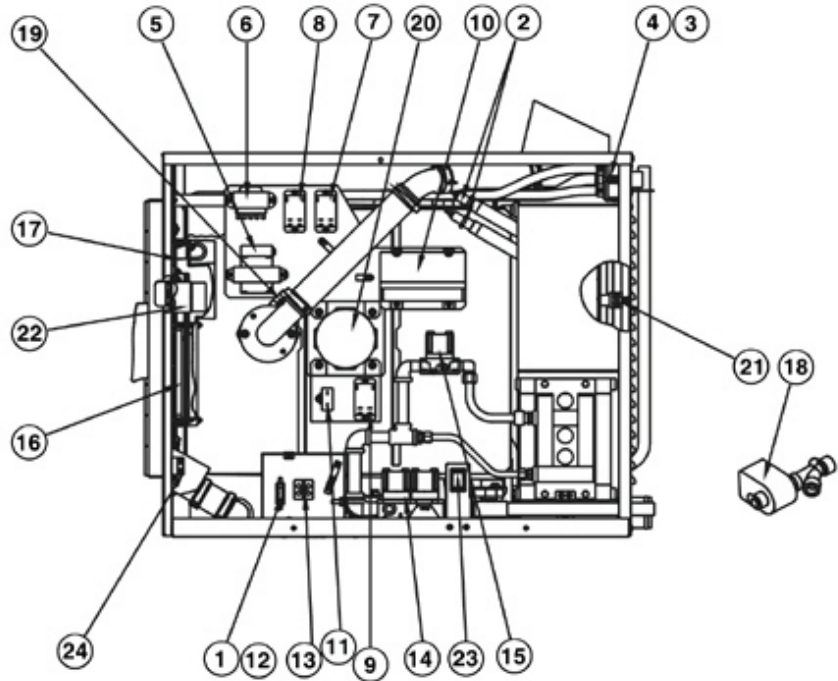

x = Item not depicted/called out in drawings

# Parts List

To order parts, contact your authorized Service Agency. Supply the model designation, serial number, part description, part number, quantity, and when applicable, voltage and phase.

KEY	DESCRIPTION	PART #
1	STEAM GENERATOR	138521
2	CAVITY	138549
3	MANIFOLD ASM - NATURAL GAS	138585
	MANIFOLD ASM - PROPANE	138586
4	INSULATION STEAM GENERATOR	138588
5	DRAIN HOSE STEAM GENERATOR	138464
6	DRAIN HOSE	138465
7	HOSE, WATER FILL	138467
8	HOSE CONDESATE	138468
9	HOSE, DELIME (SINGLE STACK)	138449
10	CAVITY INSULATION	096738
11	WATER FLOW REDUCTION	112720
12	CHECK VALVE	138428
13	GASKET	106232
14	PRESSURE RELIEF	132183
15	HOSE, 10 1/2" STEAM INLET	138445
16	HOSE, 7 7/8" STEAM INLET	138446
17	TRAP	106229
18	HOSE, TRAP	138451
19	TUBE, HIGH FIRE	138425
20	TUBE, LOW FIRE	138426
21	TUBE, PILOT	138427
22	HOSE, VENT	138447
23	DEIME TANK ASM	138415
X	HOSE, DELIME (DOUBLE STACK)	138450

x = Item not depicted/called out in drawings

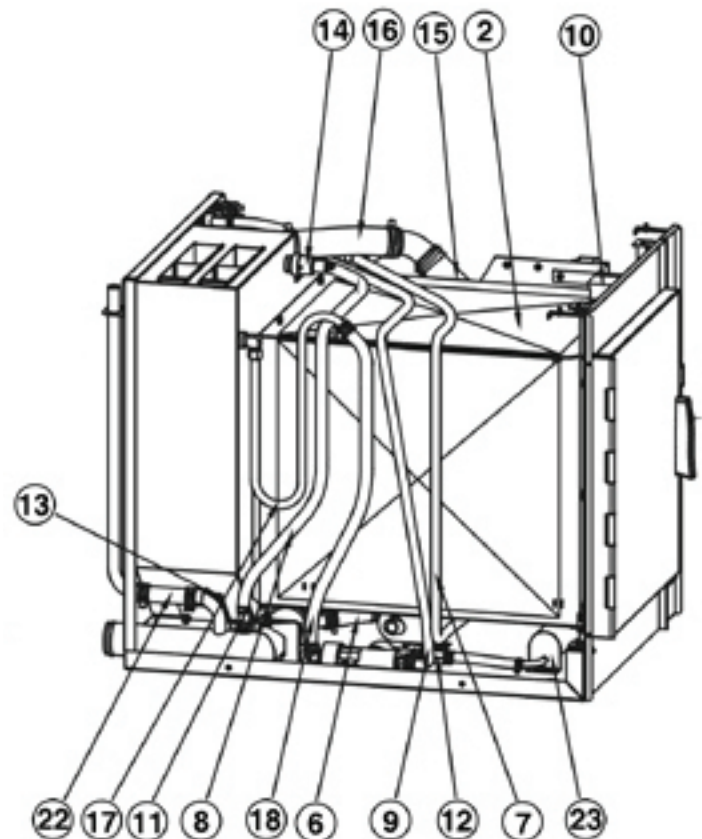
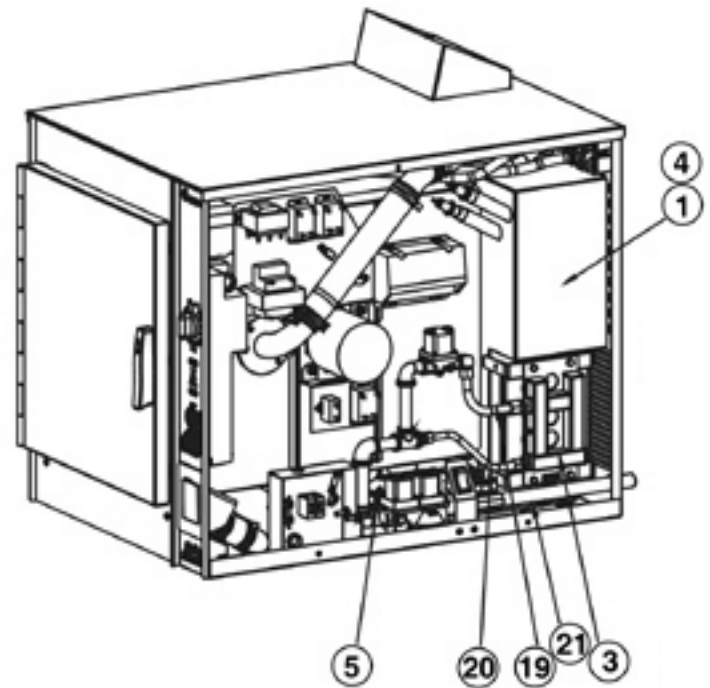

# Electrical Schematic

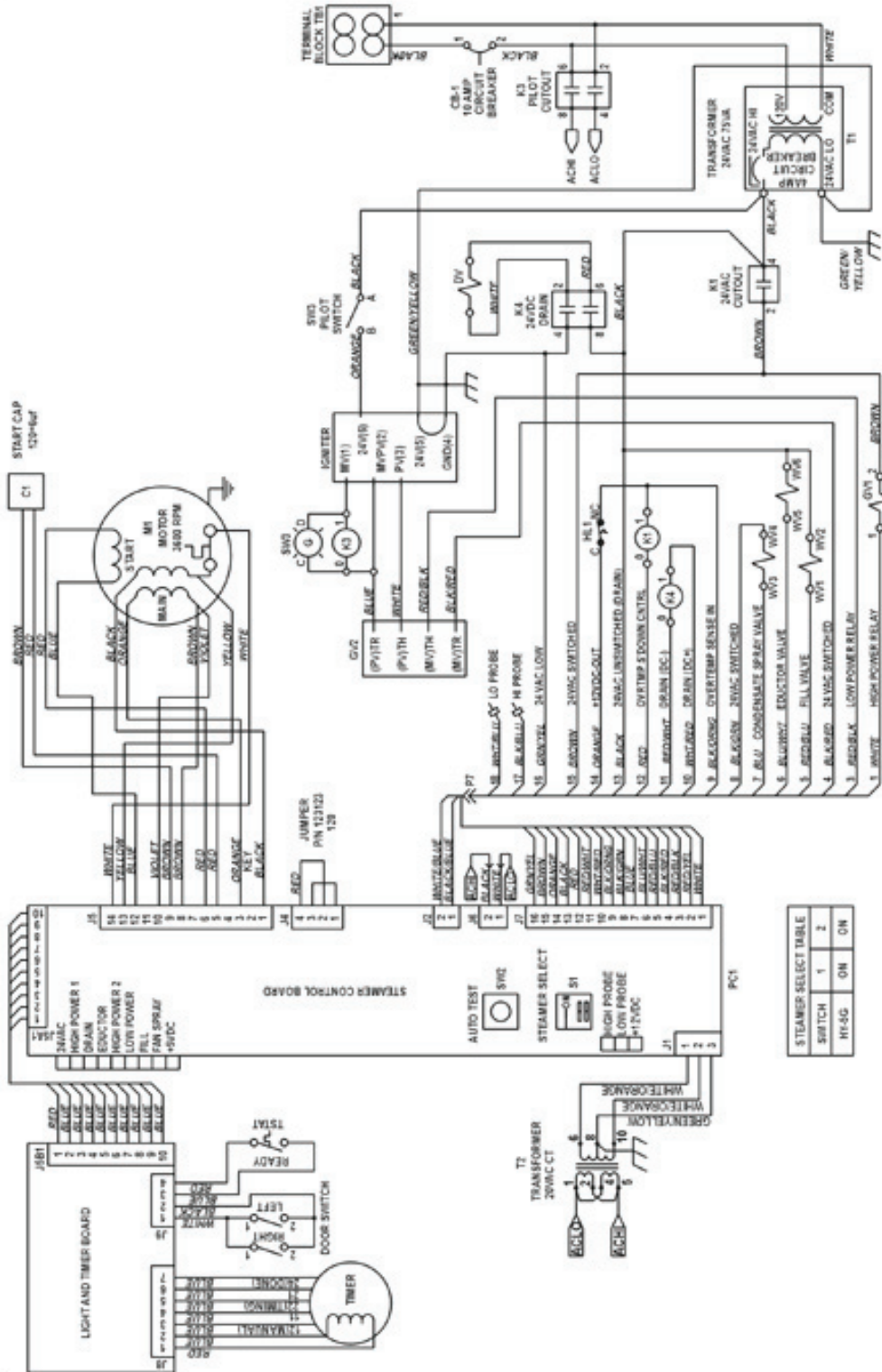



# Service Log

Model No:	Purchased From:
Serial No:	Location:
Date Purchased:	Date Installed:
Purchase Order No:	For Service Call:

Date	Maintenance Performed	Performed By

# Service Log

Model No:	Purchased From:
Serial No:	Location:
Date Purchased:	Date Installed:
Purchase Order No:	For Service Call:

Date	Maintenance Performed	Performed By





**BLODGETT OVEN COMPANY**

**[www.blodgett.com](http://www.blodgett.com)**

**44 Lakeside Avenue, Burlington, Vermont 05401 USA  
Telephone: 866-518-3977**