

INSTALLATION • OPERATION • MAINTENANCE

BLODGETT

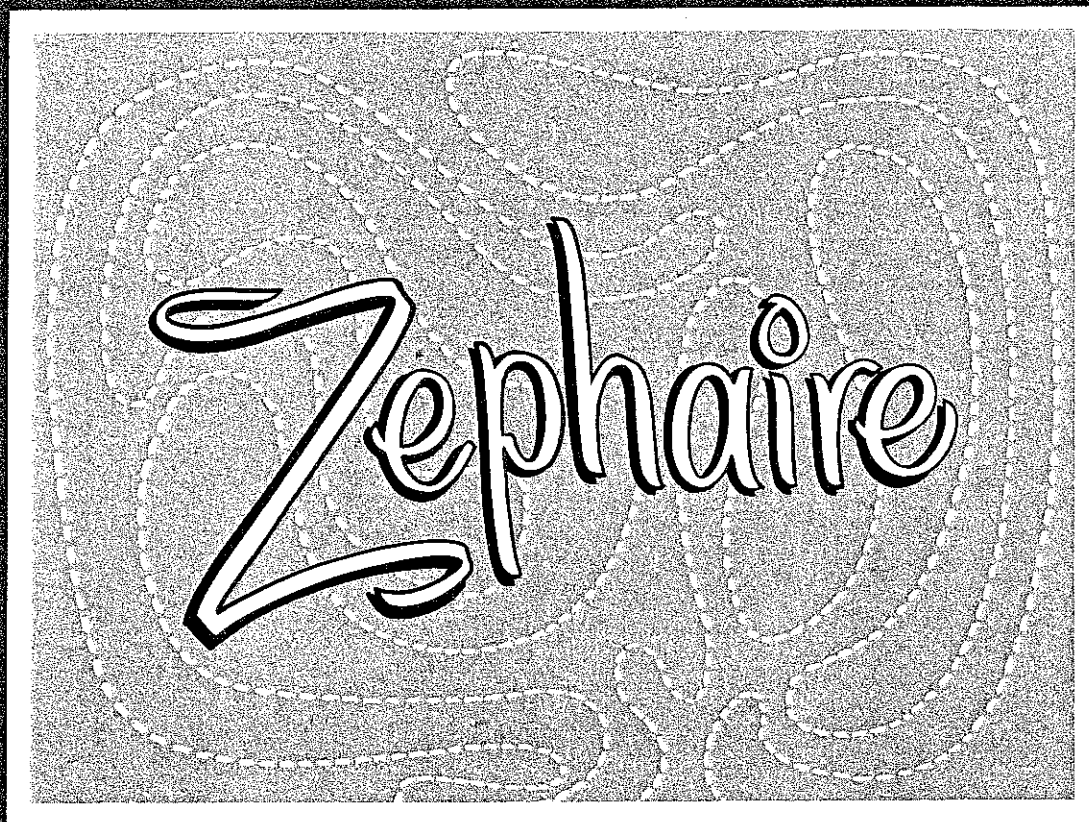

FA-100
FA-102
FA-100-RI
FA-102-RI

GZL-10
GZL-20
GZL-10-RI
GZL-20-RI



GAS



FORCED CONVECTION OVENS

OVEN SPECIALISTS SINCE 1848

THE G. S. BLODGETT COMPANY, INC.

50 LAKESIDE AVENUE, BOX 586

BURLINGTON, VERMONT 05402

APRIL 1980

INDEX

<p><i>Page</i></p> <p>1 Installation</p> <p>2 Installation</p> <p>3 Adjustment</p> <p>4 Adjustment</p> <p>5 Operation</p> <p>6 Maintenance.</p> <p>7 Maintenance.</p> <p>8 Maintenance.</p> <p>9 Maintenance.</p> <p>10 Maintenance.</p> <p>11 Maintenance.</p> <p>12 RI Installation</p> <p>13 Operation</p> <p>14 Operation</p> <p>15 Trouble Shooting</p> <p>16 Trouble Shooting</p>	<p>Before Assembly — Assembly</p> <p>Connection — Ventilation</p> <p>Doors — Main Burner</p> <p>Gas Flames — Pilot Burner, Thermostat</p> <p>Lighting & Pre-Heating</p> <p>Controls, Operation</p> <p>Cleaning, Removal & Replacement of Parts</p> <p>Removal & Replacement of Parts</p> <p>Removal & Replacement of Parts</p> <p>Removal & Replacement of Parts</p> <p>Removal & Replacement of Parts</p> <p>Leveling & Alignment</p> <p>General Notes</p> <p>Suggested Times & Temperatures</p>
---	---

Back Cover — Gas Data for *YOUR Oven.*

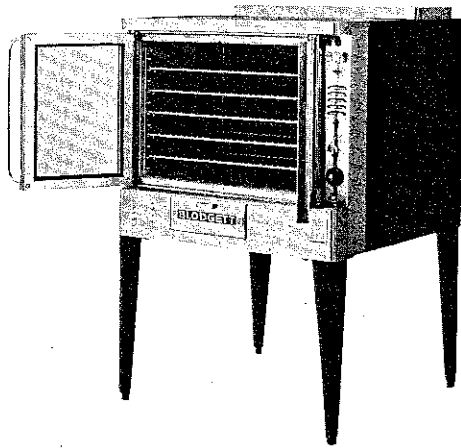

ZEPHAIRE MODEL FA-100 & GZL-10

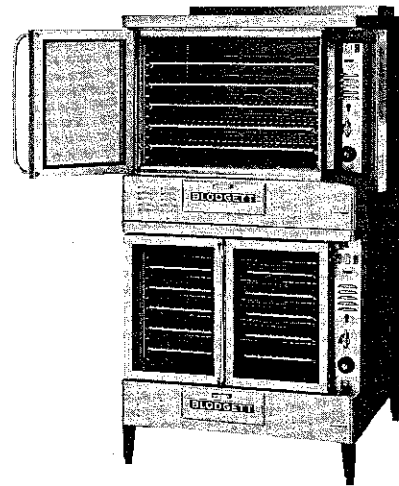

ZEPHAIRE MODEL FA-102 & GZL-20

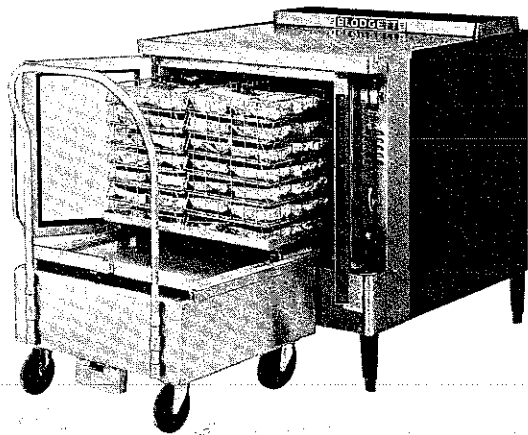

ZEPHAIRE MODEL FA-100-RI & GZL-10-RI

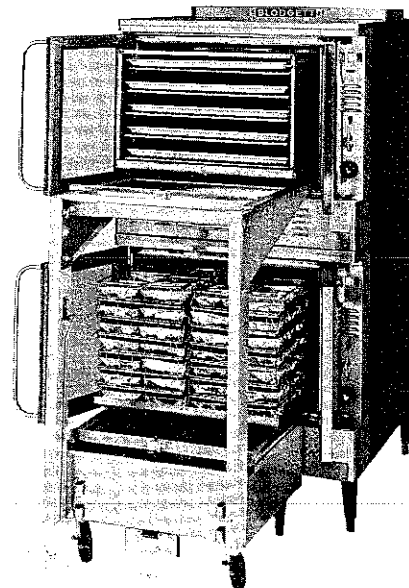

ZEPHAIRE MODEL FA-102-RI & GZL-20-RI



American Gas Association
Laboratories



Canadian
Gas Association



National
Sanitation Foundation

BLODGETT

FORCED CONVECTION OVENS

The Blodgett GZL Series ovens are identical to the Blodgett FA Series ovens with the exception they are seven inches greater in depth allowing a higher gas input rating.

INSTALLATION

A. BEFORE ASSEMBLY AND CONNECTION

Check Gas Supply

1. GAS CONDITIONS FOR WHICH THIS OVEN IS FACTORY ADJUSTED ARE LISTED ON BACK COVER.

Maximum Hourly Gas Requirements

FA-100	85,000 BTU	GZL-10	100,000 BTU
FA-102	170,000 BTU	GZL-20	200,000 BTU

2. IF IT IS A COMPLETELY NEW INSTALLATION: HAVE STREET SERVICE, METER SIZE AND HOUSE PIPING LAID OUT AND CHECKED BY COMPETENT GAS AUTHORITIES. (SEE FIGURES 1 AND 2.)

3. If it is Additional Equipment or Replacement; have competent gas authorities check pressure to make certain that existing gas facilities (meter, piping, etc.) will deliver fuel at the oven with not more than 1/2" water column pressure drop. WHEN CHECKING PRESSURE, BE CERTAIN THAT OTHER EQUIPMENT ON SAME GAS LINE IS ON. (See Charts A and B). NOTE: In some areas gas is provided at exceptionally high and often fluctuating pressure. This results in serious overgasing of ovens and other equipment. Baking results are often unsatisfactory and equipment life shortened. Therefore, these ovens are factory equipped with gas pressure regulators.

4. Make certain that new piping, joints and connections have been made in a clean manner, and have been purged, so that piping compounds, chips, etc., will not clog controls. Use pipe sealant resistant to liquefied petroleum gases. "Drips" or filters, where required, are advisable.

To determine the number of cubic feet of gas needed, divide the BTU content of a cubic foot of gas being supplied, into total oven BTU requirements.

5. Installation in the United States must conform with the National Fuel Gas Code ANSI Z223.1-1974. Installation in Canada must conform with Installation Codes for Gas Burning Appliances and Equipment, CGA B149.1 and B149.2 and/or local codes.

CHECK FOR DAMAGE

Check crates for handling damage. After carefully uncrating, check for "concealed" damage. Report any damage immediately to carrier and dealer.

B. ASSEMBLY

To Assemble Legs

First, remove the combustion compartment cover. Tip the oven back and place the front legs on the oven so as to line up with the three attaching bolt holes, Figure 3. Two of the 1/2" bolts are pushed through the leg attaching plate, and threaded into the oven frame. The third 1/2" bolt is pushed through the corner of the oven frame, and threaded into the leg attaching plate. After installing the front legs, lift oven and attach rear legs in the same manner.

CAUTION: Be sure to attach each leg with three (3) bolts.

To Assemble FA-102 & GZL-20

1. Attach legs, 6" (152mm) legs, to lower section.
2. Place upper section on top of lower section. (Do not remove crown angle from lower section).

METER CAPACITIES	
Meter Capacities, Cu. Ft. Hr. (Continuous Service)	
Meter	Cap. Cu. Ft. an Hr.
5A	100
5B	150
10A	275
20A	600
30A	700
60A	1200
150	2200

FIG. 1

CAPACITY OF PIPES							
Capacity of pipes in Cubic Feet of Gas Per Hour							
Length of Pipe in Feet	SIZE						
	3/4"	1"	1 1/4"	1 1/2"	2"	3"	4"
10	212	425	725	1170	2360	6250	12800
20	150	300	510	810	1700	4500	9300
30	122	252	425	670	1400	3750	7500
40	105	218	370	580	1200	3200	6400
50	95	195	330	520	1080	2850	5800
75	77	160	270	420	865	2300	4800
100	66	134	232	365	740	2000	4200
150	55	110	190	300	620	1680	3500

For EACH elbow or tee bend add			
1"	2 feet	2"	5 feet
1 1/4"	2.6 feet	3"	9 feet
1 1/2"	3.5 feet	4"	14 feet

FIG. 2

NOTE: Minimum clearance from combustible materials, 6 inches side — 6 inches back.

WARNING: Check gas connections for leaks using soap solution or similar means.
DO NOT CHECK BY OPEN FLAME

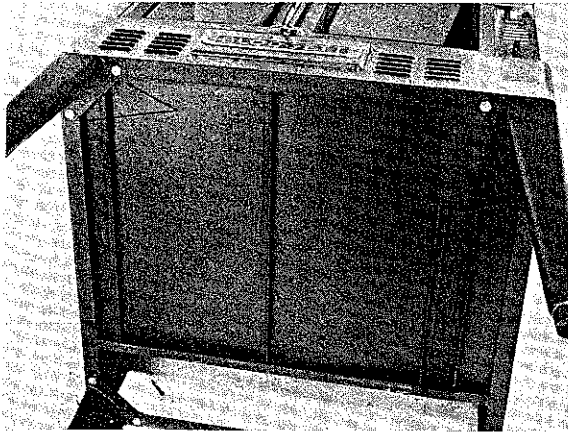

FIG. 3

WARNING: Remove flue boxes on back of single ovens when stacking for double ovens.

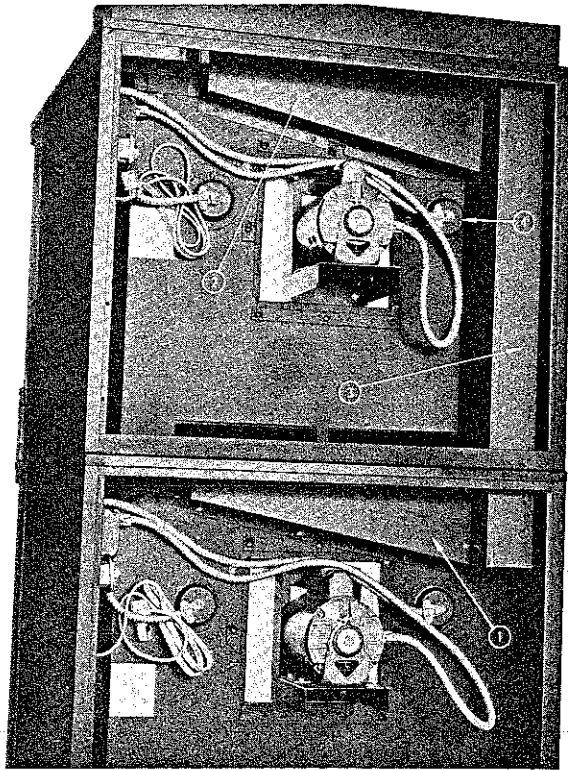

FIG. 4

To install the two front bolts, remove the combustion compartment cover of the upper section. Place the bolts through the holes in each front corner, and screw them into the nuts located in the top front corners of the lower section.

To install the two rear bolts, place the bolts through the hole in the top right and left hand frame angles of the lower section, and screw them into the nuts welded to the bottom right hand and left hand frame angles of the upper section.

4. The flue for the FA-102 or GZL-20 consists of three pieces. (Figure 4, No. 1) A lower flue box (Figure 4, No. 2) an upper flue box and (Figure 4, No. 3) a riser which connects the two flue boxes. These three pieces are put into position and fastened to the oven and to each other with the sheet metal screws, as shown.
5. When stacking two single ovens which are not ordered as a double oven, it will be necessary to remove the flue boxes on each single oven (Figure 6, No. 2) and then install 3 piece flue as described in Paragraph No. 4 above.

Installation of the Trim Collar & Draft Hood

1. Remove collar from its shipping position at rear of oven, as shown in (Figure 5, No. 1).
2. Place draft hood (Figure 7, No. 1) with angle on bottom facing toward front of oven. Place draftdiverter (Figure 6, No. 1) with open end toward rear of oven. Secure both ends of draft hood or draftdiverter with sheet metal screws provided. (Note: On the FA-102 or GZL-20 the draft hood must be put on last.)
3. Install collar in proper position as shown in (Figure 5, No. 2 and Figure 8 & 9, No. 1).
4. Remove protective coating from stainless steel portion of trim collar.

Leveling

FA-100 & GZL-10 ovens have a leveling adjustment at the bottom of each leg. Start with this adjustment screwed all the way in. With a spirit level first placed on top front of the oven, check and level from side to side. Next, place the spirit level on the top right or left side. Check and level oven from front to back.

C. GAS CONNECTION

FA-100 & GZL-10 ovens have a 3/4" gas connection at a pressure regulator when ordered for natural or propane gas.

PLEASE NOTE: It is very important that adequately sized piping be run directly to point of connection at oven, with as few elbows or tees as possible. Bush down to oven connection size AT oven. Refer to piping charts (Figures 1 and 2), or consult local gas company for piping size.

ALWAYS INSTALL AN ACCESSIBLE SHUT-OFF VALVE ADJACENT TO OVEN.

D. ELECTRICAL CONNECTIONS

The electric motor, oven lights, indicator lights, and related switches, are all connected through the 6 ft. (1.8m) electric supply cord (115 Volts AC ovens only) found at the rear of the oven. Normal factory connections are made for operation of the electrical equipment on 115 or 230 Volts AC 60 cycle. The oven must be electrically grounded when installed if an external electrical source is utilized. This appliance, when supplied for 115 volts, is equipped with a three prong (grounding) plug for your protection against shock hazard and should be plugged directly into a properly grounded three prong receptacle. Do not cut or remove the grounding prong from this plug.

NOTE: Canadian units will not be supplied with the 6 ft. (1.8m) cord. Electrical connection must be made directly to the junction box.

E. VENTILATION

Proper ventilation is highly important for good oven operation.

The ideal method of ventilating a bake oven is the use of a properly disengaged hood which should extend at least 6" (152mm) beyond all sides of the appliance (except against the wall, if it be a wall installation).

This is usually part of a single or dual speed mechanical exhaust system. Filters are located in the openings to the exhaust ducts.

All ovens operating under a hood should be equipped with a special draft diverter (Figure 6, No. 1 and Figure 9, No. 2) to insure proper oven operation.

Wherever a direct flue is unavoidable, it is necessary that:

- (1) the draft hood, shipped with the oven (Figure 7, No. 1 and Figure 8, No. 2), be installed;
- (2) an adequately sized automatic draft check be installed in the flue line as close to the oven connection as possible whether such direct flue be mechanically or stackdraft exhausted. (Not applicable in Canada.)

A steel, galvanized or transite flue should rise at least to 10 feet (3m) above the roof of the building in which it is installed, or 10 feet (3m) above any proximate higher structure, and should be equipped with a well designed cap or spinner.

Never, under any circumstances, install a damper or place steel wool in an oven flue.

Do not permit fans to blow directly at the oven, and wherever possible, avoid open windows adjacent to oven sides or back, and wall type fans which create air cross-currents within the room.

It is also necessary that sufficient room air ingress be allowed, to compensate for the amount of air removed by any ventilating system. Otherwise, a subnormal atmospheric pressure will occur, affecting oven operation adversely and causing undesirable working conditions.

A properly designed and installed hood will act as the heart of the ventilating system for the room or area in which the oven is installed, and will leave the oven independent of changing draft conditions.

ADJUSTMENT

A. DOOR OPERATION AND ADJUSTMENT

1. The FA-100 & GZL-10 features side-mounted doors which operate simultaneously. The doors are properly adjusted when the appliance leaves the factory. However, should field adjustment be necessary, two adjustable turnbuckles (Figure 10, No. 1) are located immediately behind the combustion compartment cover (CAUTION: THE TURNBUCKLES ARE LOCATED IN A HEAT ZONE). When the doors are in proper adjustment, the door without the handle should be fully closed when the door with the handle has 1/2" to 1" (12 to 25mm) of travel left before being fully closed. Proper adjustment is made by turning first one turnbuckle, then the other, until the doors are adjusted as described above.

CAUTION: If one turnbuckle is adjusted, the other must be adjusted to prevent undue strain on the door operating mechanism. When the proper adjustment has been made, be sure to tighten the turnbuckle lock nuts (Figure 10, No. 2). The turnbuckles should be tight but not over-tight.

To preclude excess play in the doors, be sure to tighten the two lower hinge pin bolts located at the inside lower edge of each door.

To adjust the ball plunger catch insert spanner key (supplied in manual) in notches on both sides of ball plunger (See inside back cover) and loosen jam nut with wrench. Adjust ball plunger by turning left or right with spanner key until plunger engages in striker plate on door for best operation. With spanner key still inserted in ball plunger notches, tighten jam nut and oven door is ready for normal operation.

2. The door-activated blower switch should be adjusted so the doors are about one and one-half inches out from the liner when the switch shuts off the blower. If field adjustment is necessary, the switch can be reached by removing the combustion compartment cover. Open right hand oven door so it is about two inches from the liner. Place arm of cam assembly located on door sprocket against push button then tighten set screw. When the doors are fully closed the cam arm depresses the push button enough to allow blower operation. An audible click can be heard to determine if switches are operating in adjustment. This switch may be moved forward or backward in mounting bracket as necessary for alignment.

B. MAIN BURNER

Satisfactory performance of ovens is as dependent upon correct adjustment of burners and controls as that of the automobile engine is

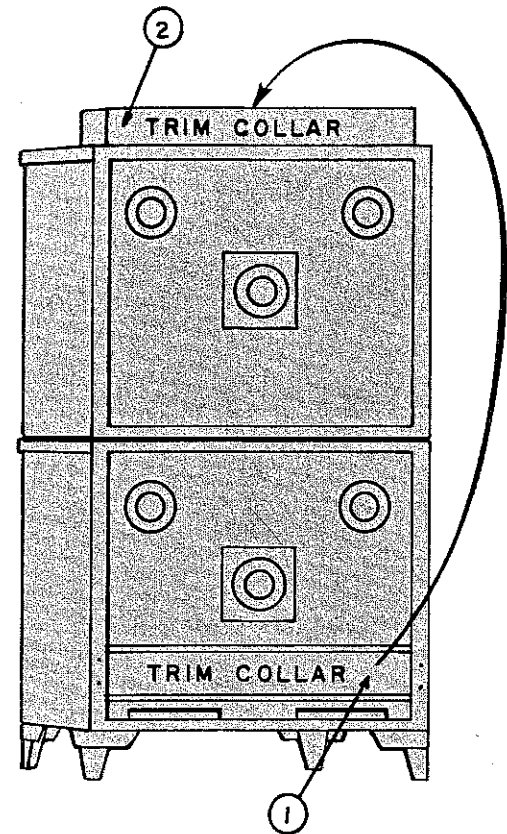

FIG. 5

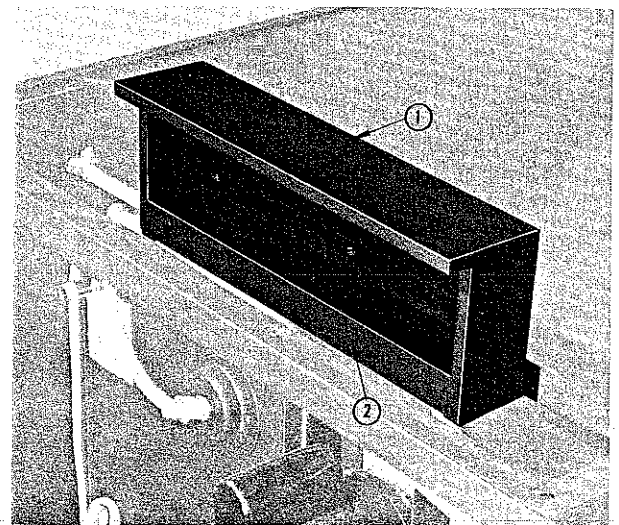

FIG. 6

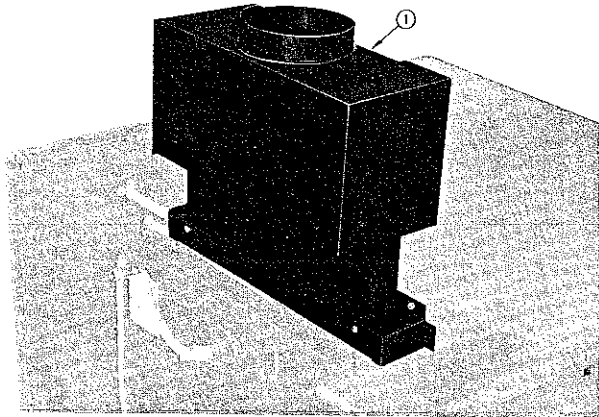

FIG. 7

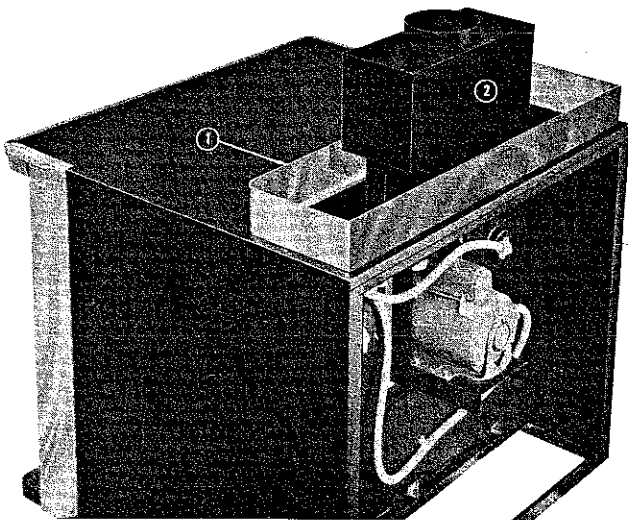

FIG. 8

upon correct carburetor and timing adjustment.

While your oven has been factory adjusted to conditions given on the order, it sometimes happens that actual premises conditions are different. It may be necessary, therefore, to make a field adjustment to fully secure satisfactory performance.

Step 1: Note the fuel characteristics as listed on the back cover of the copy of this manual accompanying your oven. Listed also are pilot, orifice and burner port sizes. If any radical difference exists (as, for example, if oven is for natural gas, and LP or other type gas is being supplied) notify your dealer immediately.

Types of gas are designated as follows: MFG-manufactured; NAT—natural; MIX—mixed; LP—liquefied petroleum.

Step 2: Check gas pressure at the manifold, this should be approximately 4.8" (122mm) W.C. on natural gas and approximately 10" (254mm) W.C. on LP gas.

Step 3: (WHEN CHECKING PRESSURE, BE CERTAIN THAT OTHER EQUIPMENT ON THE SAME GAS LINE IS "ON".)

If the pressure is more than 1/2" (13mm) water column different, have piping and meter checked for adequate capacity. If the utility furnishes gas at a constant low pressure it will be necessary to enlarge the main burner orifices.

To remove orifices from manifold (Figure 12, No. 1):
(1) Remove manifold bolts (Figure 10, No. 3) disconnect manifold union (Figure 10, No. 4) and slide manifold away from oven just far enough to permit the removal of the orifices with the proper size wrench.

Step 4: ADJUST BY-PASS FLAME:

The Robertshaw FDO thermostat is a fast throttling snap-acting control. When temperature reaches dial setting, the flame drops to by-pass (low). If temperature in oven builds 25-28° F (10-15° C) above dial setting, the snap valve shuts off burner completely.

Adjust the by-pass flame in the following manner:

1. Set oven thermostat at 400° F (205° C) on a cold oven (not pre-heated).
2. Turn the by-pass adjusting screw (Figure 13, No. 4) counterclockwise three full turns.
3. Turn thermostat dial clockwise slowly, watching burner flame. Notice when flame reduces in size. At this point there should be about 10° F (6° C) swing without affecting the height of the flame.
4. After locating this point, adjust by-pass flame to approximately 3/8" (10mm) flame by turning by-pass adjustment screw clockwise.
5. Return dial to 400° F (205° C) setting.
6. Turn thermostat dial clockwise until by-pass flame is again reached. Check for proper height of the by-pass flame.
7. If by-pass flame is satisfactory, turn dial clockwise until the flame snaps out. This is to insure that control will shut off and prevent excessive build-up of temperature beyond the control setting.
8. After flame snaps out, wait about one minute before turning your thermostat up to reignite burner. Without this delay in reignition, a flashback may occur.

C. PILOT BURNER ADJUSTMENT

To insure proper operation of this oven, make sure the pilot burner is adjusted as in (Figure 12, No. 2). The flame must engulf the safety valve tip. This adjustment may be made by turning the safety pilot adjusting screw (Figure 13, No. 1) counterclockwise until size of flame is as desired. To make this adjustment insert screwdriver thru the opening in the control compartment cover just below the red button of the safety valve.

D. ADJUSTMENT AND CARE OF THERMOSTATS

Two things are important to consider when checking, adjusting or "trouble-shooting" thermostats:

1. Thermostats are not automatic in the sense that they are capable of

changing oven temperatures—which actually is a function of increasing or decreasing either heat input, or residual heat in oven. The thermostat is a device which automatically limits heat input at or below the dial setting.

2. Most operating difficulties blamed upon the thermostat or oven are not at all due to them. Insufficient gas input, low pressure, over-gassing, poor flue, incorrect mixes, over-and-under proofing, incorrect temperatures, and warping pans frequently are at fault.

To Adjust or Calibrate

Robertshaw Model FDO Snap-Throttle Type Thermostat

Thermostats are very carefully set and checked at the factory. However, vibration in transit can change calibration which should be rechecked at time of installation. The thermostat may be calibrated as follows:

1. Turn the blower on.
2. Light oven and reset heat control dial to 350° F (180° C). (If oven is hot, set control dial to point slightly above "by-pass" reading).
3. Place a reliable mercury thermometer on the shelf which has the heat control element. This should be 6" (152mm) in from the front edge and in the center of the shelf, or place a pyrometer thermocouple at thermostat bulb.
4. When the burner is very near by-pass or minimum flame (known as "rocking point," not entirely at minimum), read thermometer.
5. Take two successive readings allowing the oven to cool 100° F (55° C) or more between readings. (Turn off gas valve and open door with blower running for about five minutes, reignite gas, close door, and take second reading after burner reduces to "rocking point.")
6. If these readings are within 10° F (6° C) of thermostat setting, do not change thermostat.
7. If the readings are more than 10° F (6° C) different from thermostat setting, proceed as follows:
 - (a) Remove dial.
 - (b) With a screwdriver loosen the two calibration screws (Figure 13, No. 5) until calibration plate (Figure 13, No. 6) moves independently of the control.
 - (c) After the dial has been removed and the calibration screws loosened, turn the calibration plate counterclockwise if the oven reading is higher than the dial reading, or clockwise if the oven reading is lower than the dial reading a sufficient number of marks, and while holding in this position, tighten calibration screws firmly. The spacing of degrees between numbers on Fahrenheit dial is 50. The spacing of degrees between numbers on Celsius dial is 25.
 - (d) Replace dial.

OVEN OPERATION

A. LIGHTING

To light pilot: make sure main gas control valve is at OFF mark. Open burner compartment door, press in and hold plunger of pilot control (red button), (Figure 13, No. 2). Apply lighted match or taper to the pilot burner. After burner ignites, continue to press plunger in for about 60 seconds before releasing it. If pilot burner continues to burn, set thermostat dial at 500° F (260° C) then turn main gas valve control on and reset thermostat dial to the desired temperature. It is not necessary to relight the automatic pilot daily. At the end of each day's operation, simply turn main gas control valve off.

B. PRE-HEATING

After lighting burner, turn on blower. Blower should be on at all times during the oven operation, to prevent damage to the motor. The oven ready light will go out when the pre-set temperature is reached. When oven is operated on LP gases, it may be necessary to lower the by-pass flame so that the oven ready light goes out when the burner goes on by-pass or low flame. The Blodgett ZEPHAIRE oven will pre-

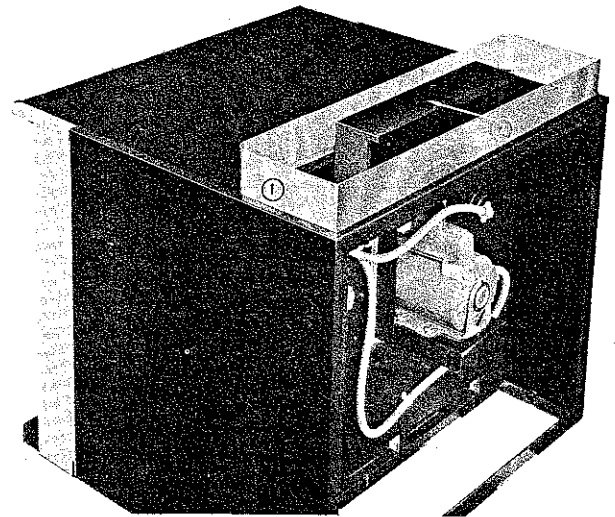

FIG. 9

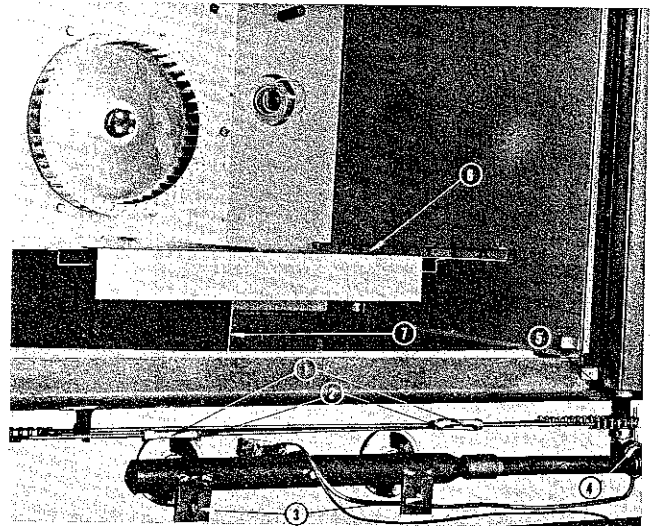

FIG. 10

heat to 350° F (180° C) in approximately 12 minutes. Any substantial increase or decrease in this pre-heat time is an indication of under or over-gassing of the oven. Have the gas checked.

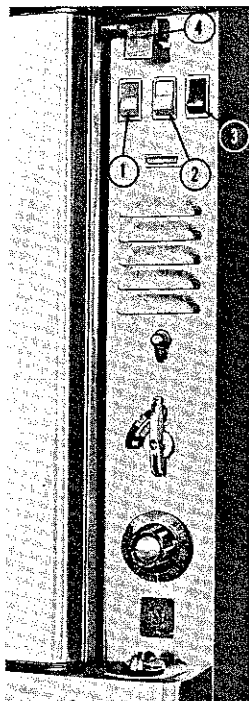

FIG. 11

C. CONTROLS

1. Located on the control panel is the thermostat which controls the oven temperature. Three switches marked "Blower", "Lights" and "Cool Down" operate related equipment with power connected to appliance. Located below the three switches is an indicator light that shows oven ready.

D. OPERATION

1. The blower is directly connected to the motor which is operated by the On-Off switch on the control panel marked BLOWER (Figure 11, No. 1).
2. When the oven doors are opened the blower is automatically shut off by a door interlock switch and regenerative braking rapidly stops blower rotation. Closing the doors will again start the blower.
3. The Man-Auto switch on the control panel marked COOL DOWN (Figure 11, No. 3), should normally be in the Auto position to allow proper automatic operation of the blower. However with the doors open the blower may be operated by placing COOL DOWN switch to Man position. This feature allows rapid lowering of temperature in the oven.

NOTE: When COOL DOWN switch is being used, thermostat should be turned to a lower setting to prevent burners from lighting during this operation.

E. INTERMITTENT IGNITION DEVICE (OPTIONAL)

This system, when supplied, replaces the conventional gas pilot in the oven. A resistance type igniter, when activated heats to an incandescent glow. A gas solenoid valve, through a relay, is opened allowing the flow of gas to the main burner. The demand of the gas flow is governed by the temperature setting on the thermostat.

The sequence of operation for an FA or GZL oven supplied with an Intermittent Ignition Device is as follows:

TO LIGHT OVEN

1. Push Blower Switch to ON
2. Turn Main Valve Handle to ON
3. Set Thermostat Dial to Temperature Desired

TO TURN OVEN OFF

1. Turn Thermostat Dial to OFF
2. Turn Main Valve to OFF

In the event the Intermittent Ignition Device does not ignite, check the following items:

1. Check igniter for broken coil, also test for break or short in igniter wire leads. Replace igniter if necessary.
2. Examine ceramic wire nuts on igniter wire leads for good contact.
3. Check thermal delay relay for operation and good seat in its socket.
4. Check solenoid valve for operation. Check wiring to solenoid valve for good contact. Replace solenoid if necessary.

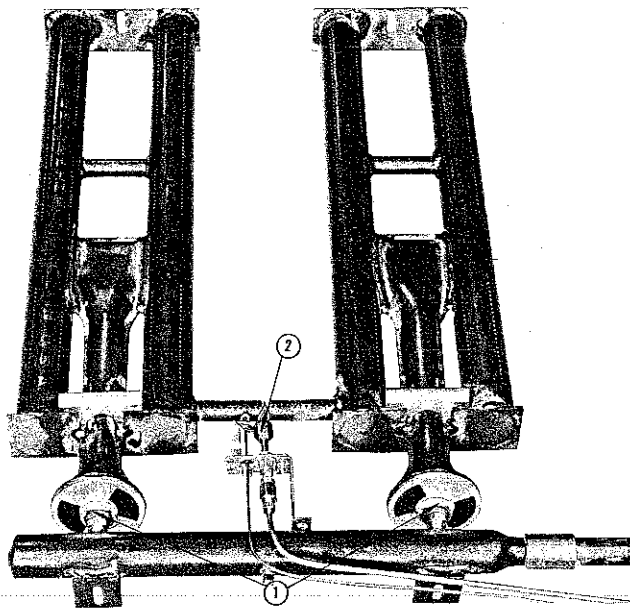

FIG. 12

Cleaning of Ovens

1. Black finish and stainless steel ovens may be cleaned and kept in good condition with a light oil, such as SHEILASHINE. Saturate a cloth and wipe oven when cold. Wipe dry with a clean cloth. On the stainless front or interiors, deposits of baked on splatter, oil, grease, or light discoloration may be removed with any of the following elements: Grade FFF Italian Pumice, Liquid Nu Steel, or Permapass, Samea or Cameo paste, Nu Steel or DuBois Temp. Heat tint or heavy discolorations may be removed with any of the following: Penny-Brite, Copper-Brite, DuBois Temp, paste Nu Steel, 5 to 15% nitric acid, or 5 to 15% phosphoric acid. Apply cleaners when the oven is cold. Always rub with the grain of the metal. When necessary, use stainless steel wool. Apply only light pressure.
2. The porcelain enamel, or stainless steel interiors of the Blodgett Zephaire oven can be easily cleaned with oven cleaners, such as JIFOAM, DOW Oven Cleaner, or EASY-OFF Spray Oven Cleaner. CAUTION should be taken to prevent these cleaners coming in contact with the aluminized panel directly in back of the blower. The racks, rack supports and blower may be cleaned by removing from the oven and soaking in a solution of ammonia and water.

Removal and Replacement of Parts

CAUTION: BEFORE PERFORMING ANY MAINTENANCE ON THIS UNIT, DISCONNECT FROM MAIN POWER SUPPLY!

(a) Door Removal:

1. Remove the combustion compartment and control compartment covers.
2. Open doors enough to disengage from ball plunger.
3. Remove the two lower hex head hinge pin bolts from each door.
4. Remove the lower of the two hex head hinge pin bolts located at the top of the door.
5. Loosen the upper of the two hex head hinge pin bolts (do not remove) and slide bolt and pin down into door.
6. Pull top of door away from the oven approximately 1 1/2" to clear top trim, lift door up and off lower hinge pin.

(b) Door Replacement:

1. Support lower hinge pins with wooden block to keep from sliding down into combustion area.
2. Follow procedure in (a) replacing parts in reverse order.

(c) Door Gasket Removal:

On ovens manufactured prior to April 12, 1965, the doors must be removed in order to change the door gaskets. On ovens manufactured subsequent to April 12, 1965, it is not necessary to remove the doors in order to change the door gaskets.

1. Remove all door gasket screws.
2. Top and bottom door gaskets will drop off when screws are removed. (All ovens prior to March, 1967.)
3. Right hand and left hand door gaskets will fall off when screws are removed on ovens manufactured prior to April

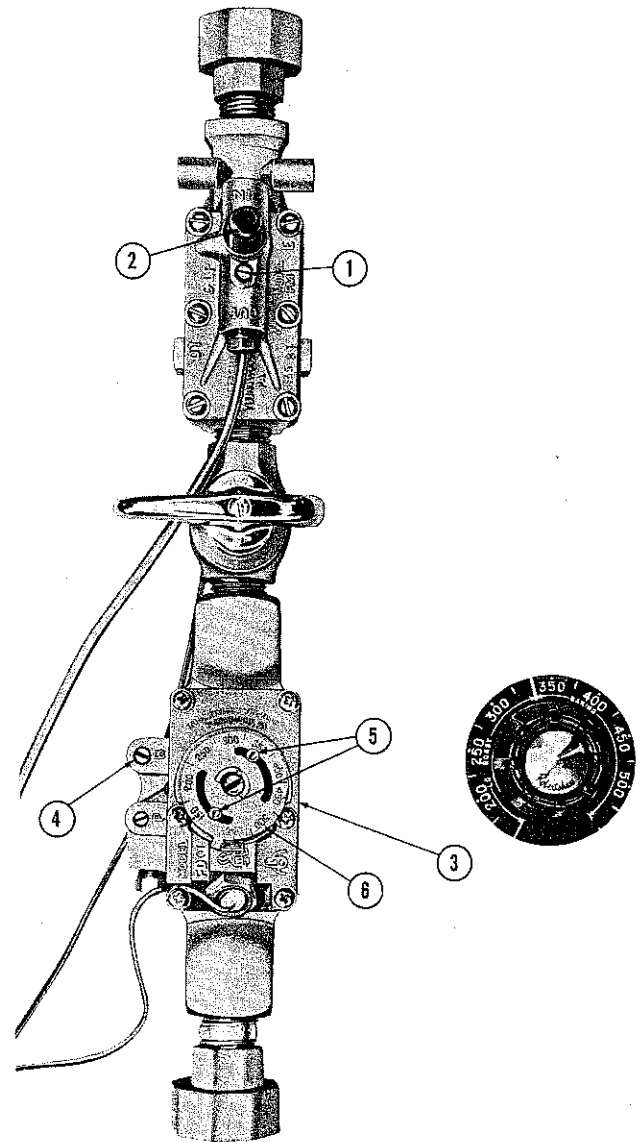

FIG. 13

12, 1965. On ovens manufactured subsequent to April 12, 1965 and prior to March 1967, the right hand and left hand door gaskets must be moved to the right and left respectively until the gasket flange is disengaged from the oven liner flange. On ovens manufactured subsequent to March 1967, the perimeter type gasket and four trim pieces readily come off when all screws are removed. On ovens manufactured subsequent to Dec. 1974, the four stainless steel gaskets and top and bottom trim pieces readily come off when all screws are removed.

(d) Door Gasket Replacement

1. Replacement of gaskets on ovens manufactured prior to March 1967, will be as follows:
 - a. Slide right hand and left hand gaskets into place (gasket flange goes behind oven liner flange).
 - b. Place upper and lower gaskets into position and replace screws.
2. Replacement of gaskets on ovens manufactured between March 1967 and Dec. 1974 will be as follows:
 - a. Put right hand and left hand trim pieces in place with notched sides under flange of oven liner.
 - b. Place upper and lower trim pieces in place and replace screws.
 - c. Line up gasket assembly on a flat surface. Make sure holes in flat wire, which is inserted in fiber glass gasket, align with holes in U shaped gasket holders.
 - d. Replace screws.
3. Replacement of stainless steel gaskets on ovens manufactured subsequent to December 1974.
 - a. Position top metal gasket over trim piece and replace four #6x3/8 screws.
 - b. Position bottom metal gasket over trim pieces and replace four #6x3/8 screws.
 - c. Place left and right metal gasket in place by sliding under pointed ends of top and bottom gaskets and replace the two #6x3/8 screws on each side.
 - d. For ovens manufactured after September 1978 left and right metal gasket ends are placed over top and bottom gasket ends, and replace the two #6x3/8 screws on each side.

(e) Manifold Orifice and Pilot Burner Removal:

1. Disconnect manifold union (Figure 10, No. 4).
2. Remove manifold bolts (Figure 10, No. 3).
3. With manifold out of oven, remove orifices or pilot burner.

 (g) Control Stack Removal:

1. Shut off gas supply to oven.
2. Disconnect from electrical supply.
3. Disconnect thermostat bulb and carefully push capillary and bulb through the oven compartment and into the control compartment.
4. Disconnect pilot burner tubing and safety pilot bulb.
5. Disconnect control stack unions (Figure 14, No. 1).
6. Remove control stack securing screws (Figure 14, No. 2).
7. Disconnect pressure switch fitting (Figure 14, No. 3).
8. Remove control stack from oven.

(h) Control Stack Replacement:

1. Follow steps in (g) replacing parts in reverse order.

(i) Deflector and Burner Divider Removal:

1. Remove shelves and rack support guides.
2. Remove baffle.
3. Remove oven compartment bottom (Figure 14, No. 7). After removing screws, slide bottom forward and out of oven.
4. Remove deflector by removing attaching screws (Figure 10, No. 6).
5. Remove burner divider (Figure 10, No. 7).

 (j) Deflector and Burner Divider Replacement:

1. Follow steps of (i) in reverse order.

(k) Blower Wheel Removal: (It is not necessary to remove motor from oven.)

1. Shut off main power supply.
2. Remove the baffle in the oven compartment.
3. Loosen the two socket head set screws on the wheel hub. (Figure 15, No. 1).
4. Screw 3/8-16 bolt into threaded disc on front of blower wheel hub. (Figure 15, No. 2).
5. Screw bolt in until blower comes off motor shaft.

(l) Blower Wheel Replacement:

1. With crocus cloth or sandpaper, remove metal burrs from motor shaft.

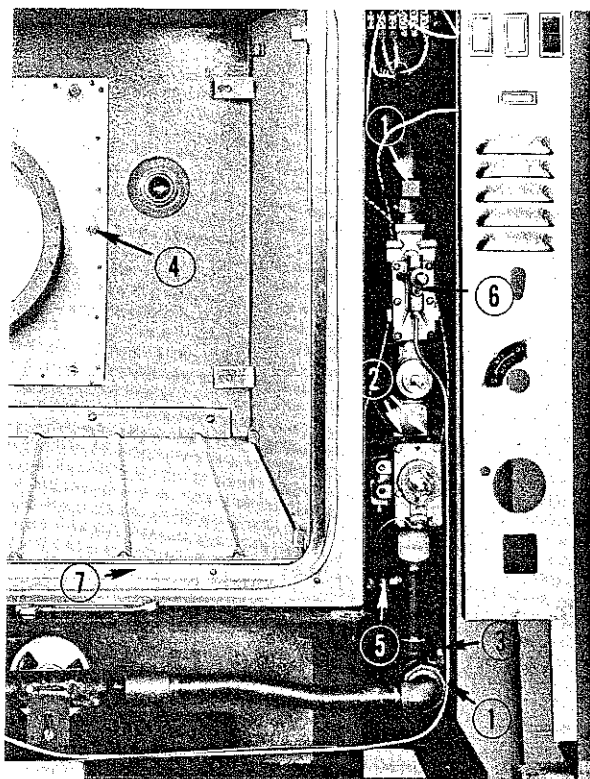

FIG. 14

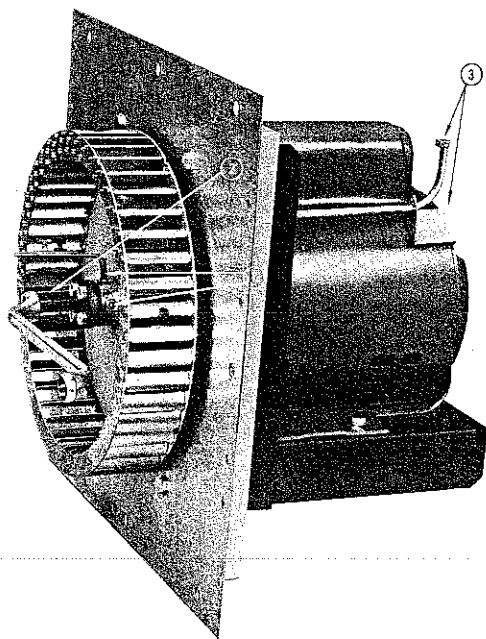

FIG. 15

2. Lubricate blower wheel hub with a high temperature, anti-seizing compound or graphite grease. (To insure ease of removal, the blower should be removed and lubricated in the above manner at least every six months.)
3. Make sure set screws do not protrude inside blower hub.
4. Place blower wheel on shaft.
5. Tap blower wheel hub with lead hammer or other soft faced hammer until motor shaft is against wheel puller.
6. First, tighten set screw which is over the key in motor shaft to 160 in/lbs torque (72 Kilograms) if torque wrench is available.

If no torque wrench is available, the required torque can be approximated as follows:

- a. Tighten set screw as much as possible by hand using a standard 5/32" allen set screw wrench.
- b. Using a small diameter steel pipe, 12 inches (305mm) long for an extension handle, turn set screw an additional 1/4 turn. An additional visual check may be made by measuring the amount of travel of the extension handle (See Fig. 17) of approximately 10" (254mm)
7. Tighten second screw as above.

(m) Motor Lubrication

On oven installations which are accessible from the back, oil motor yearly at oil caps (Fig. 15, No. 3). On installations which are not accessible from the back remove motor as in (n) and oil. CAUTION: do not over oil.

(n) Motor Removal

1. Shut off main power supply.
2. Remove the baffle in the oven compartment.
3. Remove the eight nuts from the motor mount panel (Figure 14, No. 4).
4. Grasp blower and tip forward into oven compartment.
5. With motor and panel inside oven, remove wiring plate on rear of motor and disconnect wiring.

(o) Motor Replacement

1. To remount motor follow steps in (n) replacing parts in reverse order.

NOTE: The blower wheel should rotate clockwise when viewed from front of oven.

(p) Lamp Socket Removal:

1. Shut off main power supply.
2. Remove the baffle in the oven compartment
3. Remove bulb from lamp socket.
4. Remove lamp socket cover cup from rear of oven and disconnect wires from lamp socket (Figure 4, No. 4).
5. Depress the spring clips on sides of lamp socket and push into oven compartment.

(q) Lamp Socket Replacement:

1. Place the socket in position in oven compartment and push until spring clips engage edges of porcelainized cup. (Be sure to keep the extension of the center contact of the socket pointed up.)

2. Reconnect wire leads.
 3. Replace lamp socket cover cup.
- (r) Lamp Switch, Blower Switch, Cool Down Switch and Indicator Lamp Removal:
1. Shut off main power supply.
 2. Remove control compartment cover.
 3. Disconnect wires to the switch or lamp.
 4. Depress spring clips on switch or lamp and push forward.
- (s) Lamp Switch, Blower Switch, Cool Down Switch and Indicator Lamp Replacement:
1. Push switch or lamp into proper opening in control cover until spring clips engage edges of hole.
 2. Reconnect wires.
 3. Replace control cover.
- (t) Pressure Switch Removal:
1. Shut off main power supply.
 2. Disconnect pressure switch fitting (Figure 14, No. 3).
 3. Disconnect wires from pressure switch.
 4. Remove pressure switch (Figure 14, No. 5), from spring clip bracket.
- (u) Pressure Switch Replacement:
1. Follow the related steps in (t) in reverse order.
- (v) Door Interlock Switch Removal:
1. Shut off main power supply.
 2. Remove combustion compartment cover.
 3. Remove control compartment cover.
 4. Remove wire to door interlock switch (Figure 16, No. 1).
 5. Cam assembly (Figure 16, No. 2) and interlock switch bracket (Figure 16, No. 3) accessible for parts replacement.
- (w) Door Interlock Switch Replacement:
1. Loosen cam assembly set screw on bottom of right hand door sprocket.
 2. Insert door interlock switch in bracket. Make sure bracket is centered on threaded barrel of switch and tighten retaining nuts.
 3. Open right hand door about two inches from the liner.
 4. Rotate arm of cam assembly against push button then tighten set screw. When doors are fully closed the cam arm depresses the plunger on door interlock switch enough to allow blower operation. The switch should be adjusted so that when the doors are opened one and one-half inch from liner the switch shuts off the blower. With no power on oven the switch is adjusted by the sound of the switch clicking.
 5. Carefully replace wires according to wiring diagram.
 6. Replace control compartment cover.
 7. Replace combustion compartment cover.

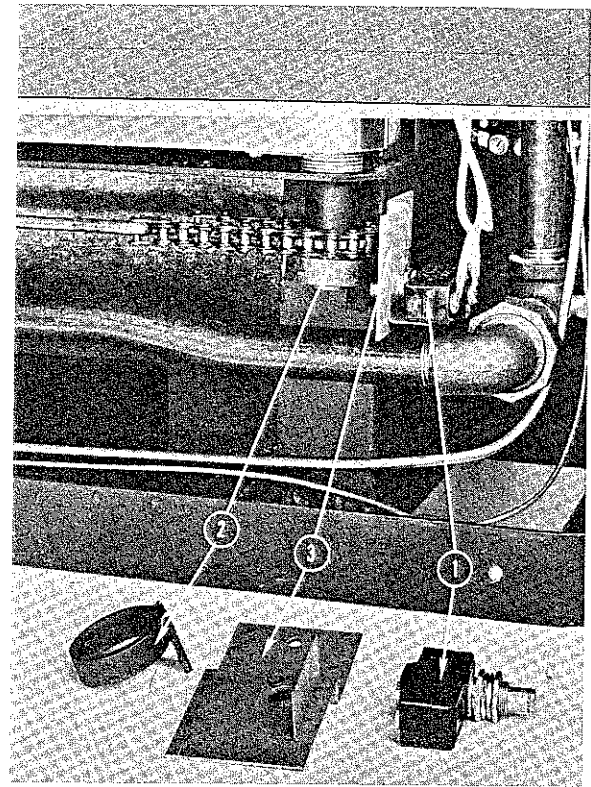

FIG. 16

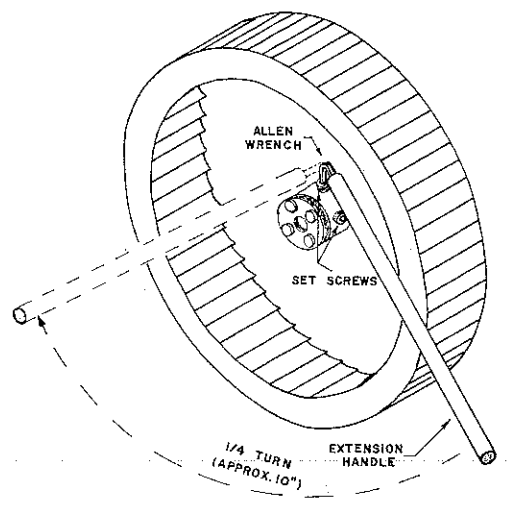

FIG. 17

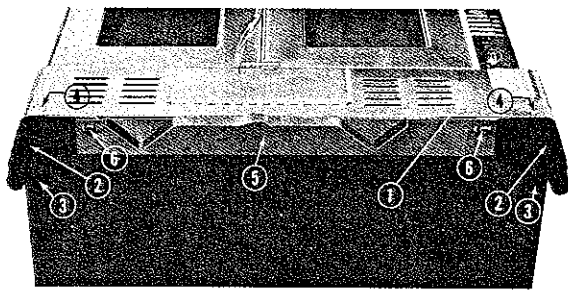

FIG. 18

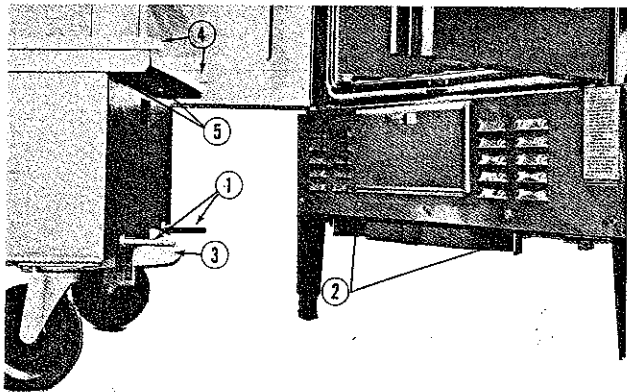

FIG. 19

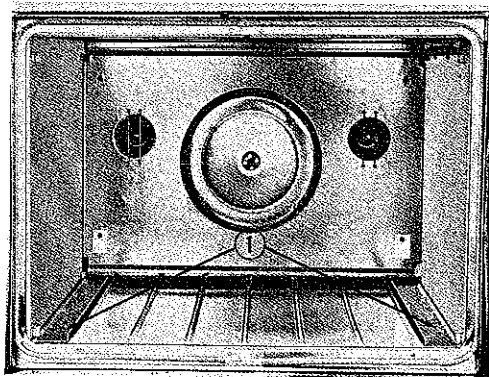

FIG. 20

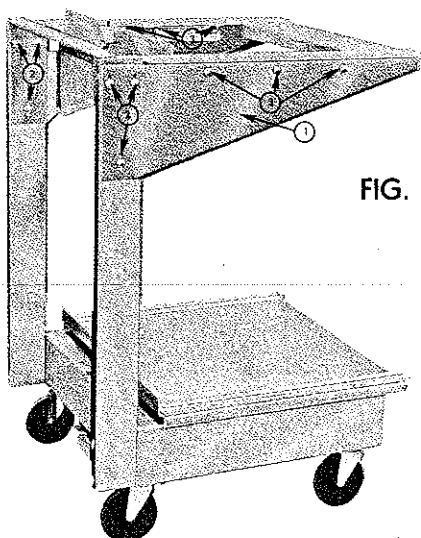

FIG. 21

INSTALLATION INSTRUCTIONS FOR FA-100-RI, FA-102-RI, GZL-10-RI, GZL-20-RI

Leg Assembly Attachment.

1. First remove the combustion compartment cover (Fig. 18, No. 1). Tip the oven back and place the front legs (Fig. 18, No. 2) so as to line up with the three attaching bolt holes. Insert two of the $\frac{1}{2}$ " bolts through the leg attaching plate and thread into oven frame (Fig. 18, No. 3). Insert two $\frac{1}{2}$ " bolts through the corner of the frame from combustion side and thread into legs (Fig. 18, No. 4). Place docking assembly (Fig. 18, No. 5) on lower frame of oven, as shown, align slots with bolt holes and insert two $\frac{1}{2}$ " bolts (Fig. 18, No. 6) and thread into oven frame. Leave these bolts loose for later adjustment. When attaching docking assembly, make sure hooks on back side are placed above the angle iron on the oven frame.
2. After installing front legs, lift oven and attach rear legs in similar manner.

LEVELING RI OVENS

1. The -RI ovens require special 7" (178mm) legs, make sure that your oven has them. If they don't, replace them (see instructions on leg attachment). Your oven has a leveling adjustment at the bottom of each leg. Start with this adjustment screwed all the way in. With a spirit level first placed on top front of the oven, check level from side to side. Next place the spirit level on the top right or left side, check oven level from front to back.
2. After leveling, note that distance from bottom side of oven to floor underneath should be as close to 7" (178mm) as possible to facilitate docking alignment to transport cart. (See Figure 19.)

TO ALIGN DOCKING MECHANISM

NOTE: Steps 1 through 4 are for a single cart and the lower platform of a double cart. Refer to step 5 for the upper platform adjustment for double carts.

1. Open oven doors fully.
2. Move and latch transport cart into place at front of oven. The two alignment pins on front of cart (Fig. 19, No. 1) should line up with channeled openings in docking assembly (Fig. 19, No. 2). The locking bar (Fig. 19, No. 3) will also lock to docking assembly. If there is difficulty with the locking bar engaging the docking assembly, adjust the assembly forward or backwards to allow latching.
3. Align inner vertical edge of tracks on transport cart (Fig. 19, No. 4) with same vertical edge of tracks located on oven liner bottom. (Fig. 20, No. 1). This adjustment can be made by moving the docking assembly either left or right. With the docking assembly adjusted for both latching and alignment tighten the two $\frac{1}{2}$ " bolts (Fig. 18, No. 6).
4. The transport cart has been adjusted for height before being shipped, however, a final adjustment may be required at the installation site. The tracks on the transport cart should be the same height as the tracks on the oven liner bottom. This adjustment is made by raising or lowering the nuts on the four leveling screws located in each corner of the transport cart (Fig. 19, No. 5).
5. Further alignment may be made by loosening screws which hold tracks in place on oven liner bottom. Move tracks, which are slotted, to left or right to line up with tracks on either single or double transport cart. Tighten screws.

DOUBLE TRANSPORT CART

When aligning a double transport cart Model CTRG-2, further adjustment may be required on the top platform assembly (Fig. 21, No. 1). The entire top platform may be raised or lowered by loosening six nuts on inside of both vertical posts. (Fig. 21, No. 2). When tracks on top platform are aligned with tracks on the upper oven liner, tighten six nuts. To adjust tracks forward or backward loosen six nuts on inside of both track support arms (Fig. 21, No. 3) of top platform and slide tracks on top platform to meet tracks on upper oven liner. When tracks are adjusted tighten nuts.

OPERATION

In forced convection ovens heated air is constantly circulated inside a closed chamber by means of a fan or blower.

The moving air continually strips away a thin layer of moisture and cool air from the top of the goods allowing the heat to penetrate more quickly, thus shortening the cooking time and permitting the use of lower temperatures.

For example, in a conventional oven sheet cake is baked at 375°F (190°C) for 25-30 minutes. In a Blodgett Zephair Convection Oven, with the temperature reduced to 335°F (170°C), the baking time is cut to 16-18 minutes.

A general rule of reducing temperature settings 50°F (25°C) from recipe temperatures used on conventional deck ovens is a good starting point. However, on some products the user may find the best results are obtained from even lower or slightly higher temperatures.

Check the product for doneness in about half the time it would take to bake in a conventional oven. Depending on the item and the type of pan used, time savings may run from 15% to as high as 50%.

If products brown on the outside and are not done inside, it means that too high a temperature is being used. On the next batch try dropping an additional 15°-25°F (10°-15°C).

In loading, keep pans toward the front of the racks. If pans are pushed to the rear, some light batters might be ingested into the blower wheel. Always load each shelf evenly, spacing pans away from each other and the sides or back of the oven.

It is unnecessary to frequently open the doors of the Blodgett ZEPHAIRE oven because of the large tempered glass windows and the interior lighting. Shifting of the product is generally unnecessary.

If blower wheel should become dirty remove and immerse 15-20 minutes in ammoniated water. Then scrub off with small stiff brush.

Normally the fan should be left on at all times even when the oven is empty between loads. Prolonged heating with the fan off will damage the motor.

It is possible to leave the fan off for a period not in excess of 10 minutes. This may be helpful on very light items such as meringue shells where baking with the fan off for five minutes will allow the product to set.

When loading oven with transport cart, be sure cart is securely locked to the oven before transferring load. To move load into oven push down on upper foot pedal (Fig. 22 No. 1) and push load into oven. The roll-in basket dolly should be all the way into the oven before removing transport cart. This prevents load spillage and allows proper door closing. To remove transport cart from oven push down on lower foot pedal (Fig. 22 No. 2) and pull cart away from oven. Close doors.

When unloading oven, transport cart must be securely locked to front before transferring load. Load is pulled from oven onto cart. **CAUTION:** Be sure basket carrier is locked securely on transport cart before releasing transport cart from oven.

Ventilating tab on control panel keeps steam in when you want moist heat . . . but permits you to let it out for dry heat (Figure 11, No. 4).

TURN ON LIGHTS ONLY TO CHECK THE PRODUCT. CONTINUAL BURNING OF LIGHTS WILL RESULT IN SHORT BULB LIFE.

DISCONNECT OVEN FROM POWER SOURCE BEFORE DOING ANY SERVICE WORK.

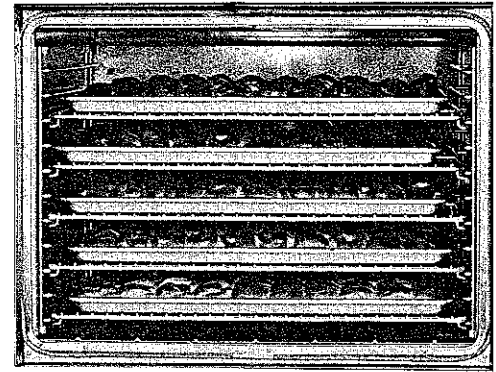

For most baking operations use five racks starting with bottom rack.

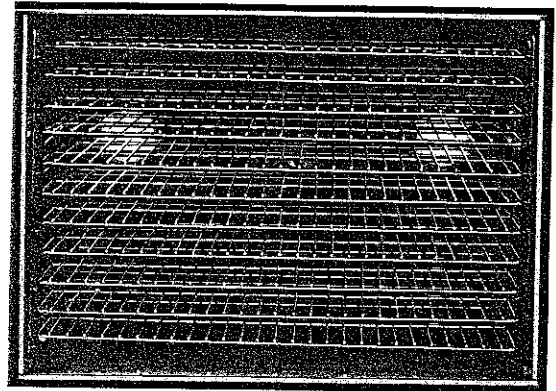

Eleven rack arrangement, an extra-cost option, speeds production of such popular items as hamburgers and frozen dinners.

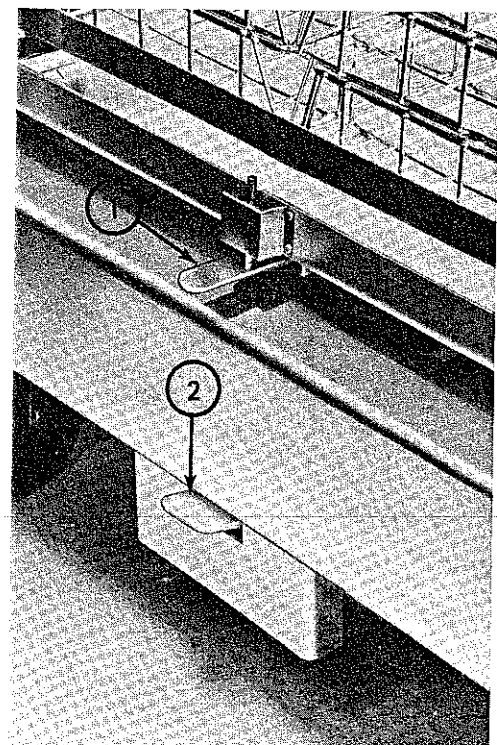

FIG. 22

SUGGESTED TIMES AND TEMPERATURES

	PRODUCT	FAHRN.	CELSIUS	TIME	# SHELVES	
MEATS <i>Beef</i>	Hamburger Patties (5 per lb.)	400°F	205°C	8—10 mins.	11	
	Meat Loaf	325°F	165°C	40—45 mins.	3	
	Steamship Round (80 lb. Quartered)	275°F	135°C	2¾ hrs.	2	
	Rolled Beef Roast (12-15 lbs.)	275°F	135°C	2½ hrs.	3	
	Standing Rib Choice (20 lbs. Trimmed, Rare)	235°F	115°C	2¾ hrs.	2	
	Banquet Shell Steaks (10 oz. meat)	450°F	235°C	7-8 mins.	5	
	Beef Pot Pies	400°F	205°C	30—35 mins.	5	
	Stuffed Peppers	350°F	175°C	15—20 mins.	3	
	Lasagna	250-270°F	130°C	90 mins.	3	
	Swiss Steak after Braising	275°F	135°C	60 mins.	5	
Hot Dogs, 10-1 lb. (18 x 26 Pan)	325°F	165°C	10—15 mins.	5		
<i>Pork, Veal & Lamb</i>	Baked Stuffed Pork Chop	375°F	190°C	25—30 mins.	5	
	Boned Veal Roast (15 lbs.)	300°F	150°C	3 hrs. 10 mins.	2	
	Lamb Chops (small loin)	400°F	205°C	7—8 mins.	5	
	Bacon (on Racks in 18 x 26 Pans)	400°F	205°C	5—7 mins.	11	
POULTRY	Chicken Breast & Thigh	350°F	175°C	40 mins.	5	
	Chicken Back & Wing	350°F	175°C	35 mins.	5	
	Chicken (2½ lbs. Quartered)	350°F	175°C	30 mins.	5	
	Turkey Rolled (18 lbs. Rolls)	310°F	155°C	3¾ hrs.	3	
	Chicken—Turkey Pot Pies	400°F	205°C	30—35 mins.	5	
FISH & SEAFOOD	Fish Sticks	335°F	170°C	16—18 mins.	11	
	Halibut Steaks, Cod Fish (Frozen 5 oz.)	350°F	175°C	20 mins.	5	
	Baked Stuffed Shrimp	400°F	205°C	6—7 mins.	5	
	Baked Stuffed Lobster (1½ lb.)	400°F	205°C	10 mins.	3	
	Lobster Tails (Frozen)	425°F	220°C	9 mins.	5	
CHEESE	Macaroni & Cheese Casserole	350°F	175°C	30 mins.	5	
	Melted Cheese Sandwiches	400°F	205°C	8 mins.	11	
POTATOES	Idaho Potatoes (120 ct.)	400°F	205°C	50 mins.	5	
	Frozen French Fries — Cooking times and temperatures will vary according to vendor.					
	Oven Roasted Potatoes (Sliced or Diced)	325°F	165°C	10 mins.	5	
BAKED GOODS	<i>Fruit Pies</i>	Frozen Berry Pies (22 oz.)	350°F	175°C	34 mins.	5 (30 pies)
	<i>&</i>	Frozen Fruit Pies (46 oz.)	350°F	175°C	45—50 mins.	5 (20 pies)
	<i>Turnovers</i>	Fresh Apple Pie (20 oz.)	350-375°F	175-190°C	25—30 mins.	5 (30 pies)
		Pumpkin Pies	300°F	150°C	30—35 mins.	5
		Fruit Crisp	300°F	150°C	25 mins.	5
		Fruit Cobbler	300°F	150°C	30 mins.	5
		Apple Turnovers	350°F	175°C	15 mins.	5
	<i>Bread & Rolls</i>	Bread (24-1 lb. Loaves)	340°F	170°C	30 mins.	3
		Corn Bread (Northern)	335°F	170°C	25 mins.	5
		Corn Bread (Southern)	375°F	190°C	15—20 mins.	5
		Hamburger Rolls	300°F	150°C	15 mins.	5
		Yeast Rolls	325°F	165°C	25 mins.	5
		Baking Soda Biscuits	400°F	205°C	6 mins.	5
		Brown & Serve Rolls	350°F	175°C	15 mins.	5
			Sheet Cakes (5 lbs. Mixed Batter per pan)	335°F	170°C	16—18 mins.
	<i>Cakes & Cookies</i>	Chocolate Cake	335°F	170°C	20 mins.	5
		Fruit Cakes	275°F	135°C	70 mins.	3
		Brownies	350°F	175°C	15 mins.	5
		Danish	335°F	170°C	12 mins.	5
		Cinnamon Buns	335°F	170°C	20 mins.	5
Sugar Cookies		300°F	150°C	15 mins.	11	
Cream Puffs		350°F	175°C	20—25 mins.	5	
Chocolate Chip		350°F	175°C	10 mins.	11	
Peanut Butter		325°F	165°C	10 mins.	11	
PIZZA		Pizza (5' Frozen)	450°F	235°C	5 mins.	5
	Pizza (Pre-baked Crust)	450°F	235°C	3—5 mins.	5	

NOTE: The suggested times and temperatures may vary considerably from those shown above. They are affected by weight of load, temperature of the product, recipe, type of pan and calibration of thermostat. Should your recipe vary write in your proven time and temperature for ready reference.

CAUTION: Before performing any maintenance on this oven, disconnect from Main Power Supply. Shut off gas supply to oven before performing any maintenance or replacement of gas lines, controls or burners.

Gas Burners Won't Light

1. Insufficient gas supply
2. Manual gas valve not on
3. Thermostat OFF or too low setting
4. Safety pilot tip (Fig. 12) not glowing cherry red from pilot burner flame
5. Safety pilot flame not lit

- a. Check that main supply line valve is open.
 - a. Turn manual gas valve to "ON".
 - a. Turn thermostat to required setting for product.
 - a. Refer to Instruction Manual Page 4, Section C — "Pilot Burner Adjustment."
 - a. Refer to Instruction Manual Page 5, Oven Operation Section A, "Lighting."

Gas Burners Won't Stay Lit

1. Oven has reached proper temperature and shut off
2. Safety Pilot tip not glowing cherry red from pilot burner flame
3. Safety Pilot flame not lit

- a. This is normal operation
 - a. Refer to Instruction Manual Page 4, Section C — "Pilot Burner Adjustment"
 - a. Refer to Instruction Manual, Page 5, Oven Operation, Section A, "Lighting."

Safety Pilot Flame Goes Out or Won't Stay Lit After Release Of Pilot Control Plunger (Red Button) ON FMEA Automatic Safety Valve

1. Pilot burner not properly adjusted
2. Flame does not engulf bulb at end of capillary and glow cherry red
3. FMEA Automatic Safety Valve defective

- a. Refer to Page 4, Section C, "Pilot Burner Adjustment"
 - a. Check for proper pilot orifice and make sure orifice is clear of any foreign material.
 - a. Remove control stack. Refer to Instruction Manual, Page 9, item (g), "Control Stack Removal." Remove and replace defective FMEA Automatic Safety valve in control stack. Replace control stack.

Defective FMEA Automatic Safety Valve

1. To test FMEA in oven: Set cold oven to 500° F (260° C), turn on Manual gas valve, heat bulb at end of capillary with Bernzomatic or Propane Hand torch until bulb is cherry to orange red. If main burner comes on full, valve is okay. If main burner comes on with low flame or will not come on, replace complete FMEA.

- a. Remove control stack. Refer to Instruction Manual, Page 9, item (g), "Control Stack Removal." Remove and replace defective FMEA Automatic Safety valve in control stack. Replace control stack.

Defective Thermostat

1. Thermostat will not shut off burners at temperature setting (Runaway thermostat)
2. Thermostat will not maintain calibration per instruction. Refer to Installation Manual, Page 5, "To Adjust or Calibrate FDO Thermostat."
3. Thermostat bulb or capillary are cut, bent or unnecessarily flattened.

- a. Replace thermostat. Refer to Instruction Manual, Page 9, item (g), "Control Stack Removal." Remove and replace defective thermostat in control stack. Replace control stack.
 - a. Replace thermostat. See 1 (a) above.
 - a. Replace thermostat. See 1 (a) above.

NOTE: Most operating difficulties blamed upon the thermostat are not necessarily true. Insufficient gas input, low pressure, over gassing, poor flue, incorrect mixes, over and under proofing, incorrect temperatures and warping pans frequently can be at fault.

Indicator Light Inoperative

1. If full flames on burners and indicator light will not operate

- a. Check electrical supply to oven.
- b. Replace indicator light. Refer to Instruction Manual, Page 11, item (r), "Indicator Lamp Removal."
- c. Replace Pressure switch. Refer to Instruction Manual, Page 11, item (t), "Pressure Switch Removal."

NOTE: Wiring Diagram for this oven is supplied in Installation Manual. Also, one wiring diagram label is found on back of oven near junction box and one inside of removable control panel.

Blower Motor Inoperative

1. Blower switch ON, Cool down switch AUTO, doors closed.
- d. Check door interlock switch operation. Refer to In-

Blower Wheel Noisy

1. Blower rubbing on compartment baffle.
2. Blower rubbing on motor mount front panel.
3. Blower loose on motor shaft.
4. Blower loose on motor shaft and motor shaft badly worn.

Lights Inoperative

1. Light switch ON

- a. Check for proper electrical supply to oven.
- b. Check blower switch for proper continuity. Replace if faulty. Refer to Instruction Manual, Page 11, item (r).
- c. Check cool down switch for continuity. Replace if faulty. Refer to Instruction Manual, Page 11, item (r).
- d. Check door interlock switch operation. Refer to Instruction Manual, Page 11, item (w) paragraph 4. Replace if faulty. Refer to Instruction Manual, Page 11, item (w).
- e. Replace Motor. Refer to Instruction Manual, Page 10, item (n), "Motor Removal."

- a. Move motor back in motor mount. Found from rear of oven.
- a. Move motor forward in motor mount. Found from rear of oven.
- a. Re-tighten blower. Refer to Instruction Manual, Page 9, item (l), "Blower Wheel Replacement," paragraph 6.
- a. Replace motor and blower wheel. Refer to Instruction Manual, Page 10, item (n), "Motor Removal" and Page 9, item (l), "Blower Wheel Replacement."

- a. Check for proper electrical supply to oven.
- b. Remove baffle in rear of oven compartment by removing 3 wing bolts. Remove and replace defective light bulbs. Replace baffle.
- c. Check light switch for continuity. If defective replace. Refer to Instruction Manual, Page 11, item (s), "Lamp Switch Replacement."

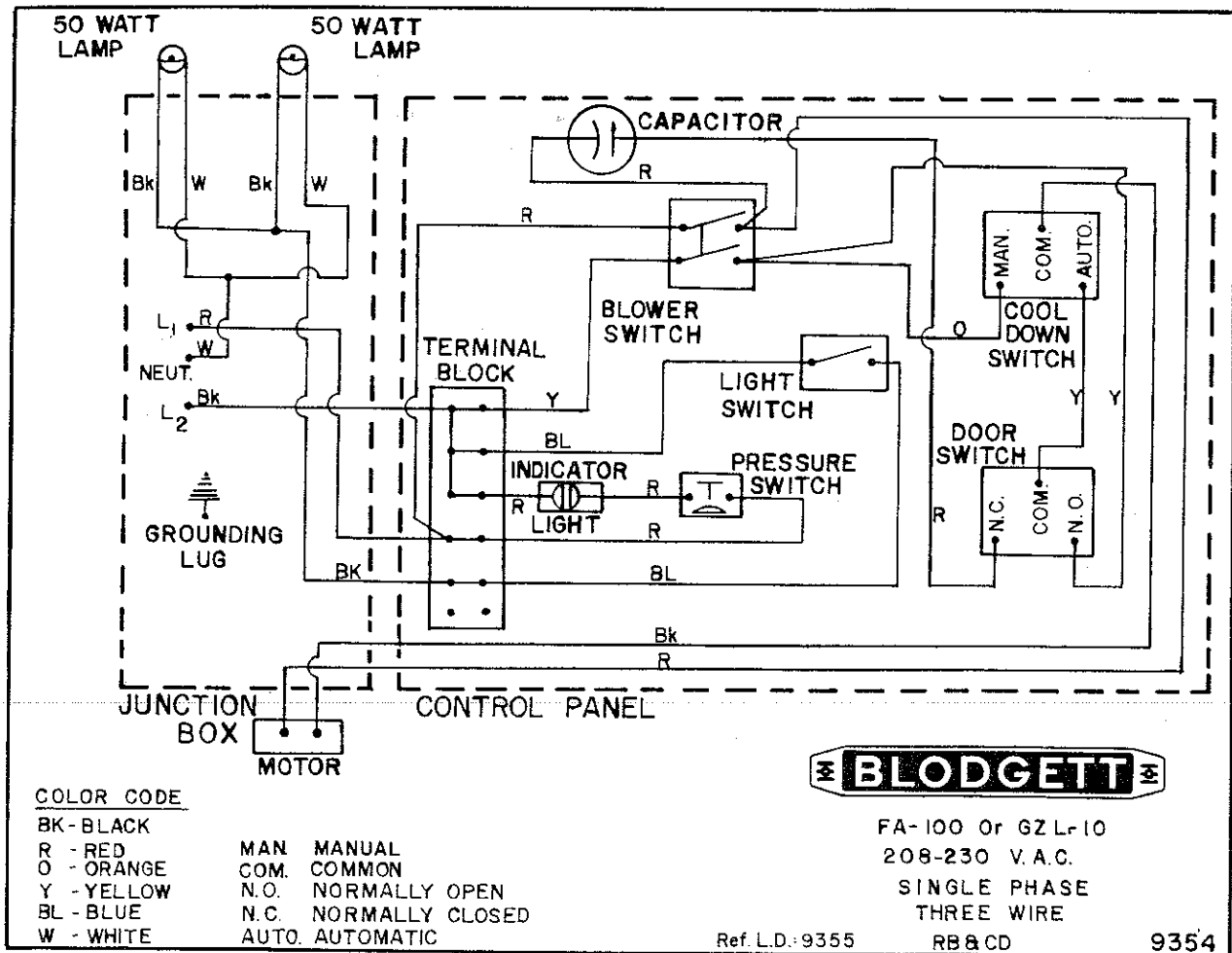
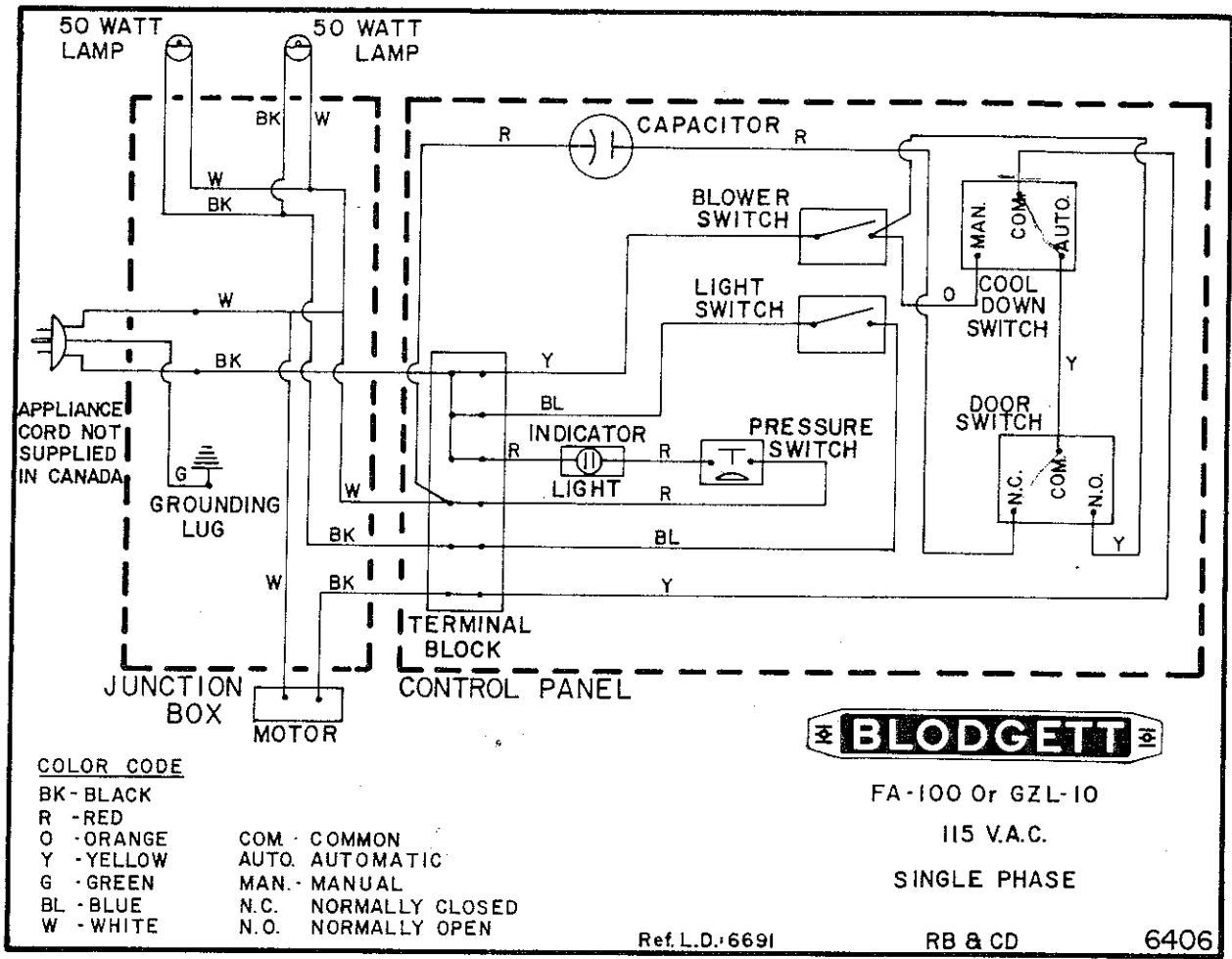

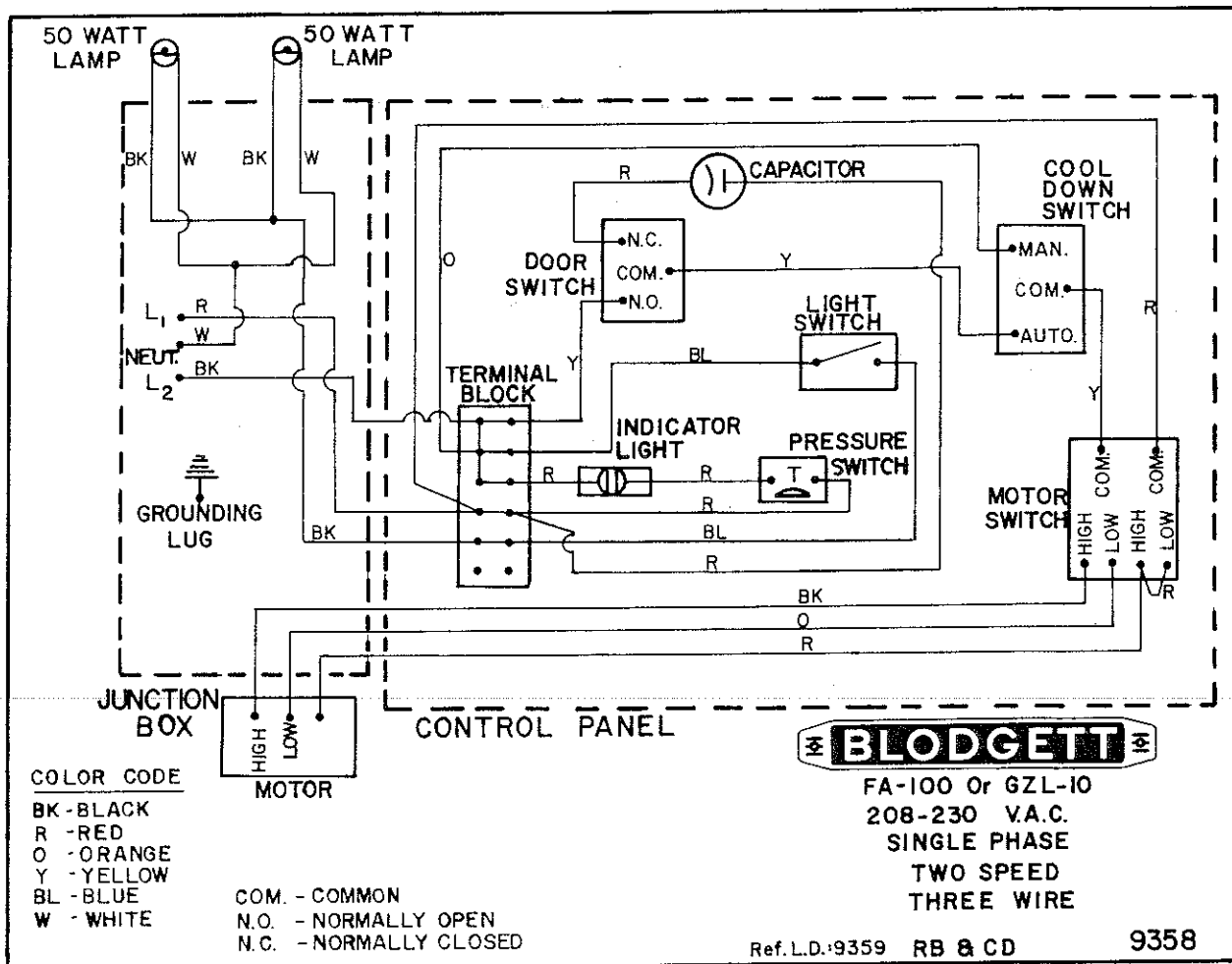
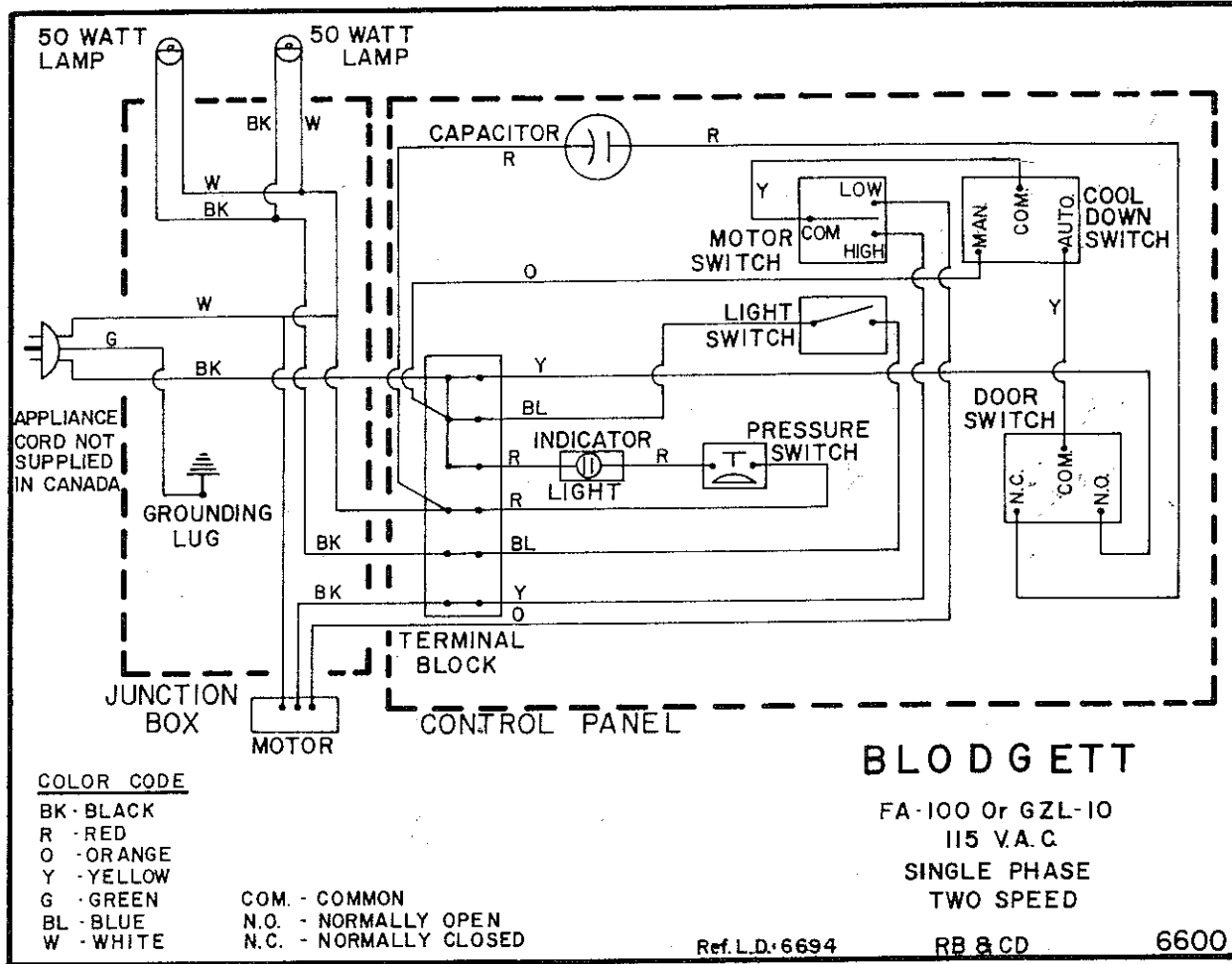

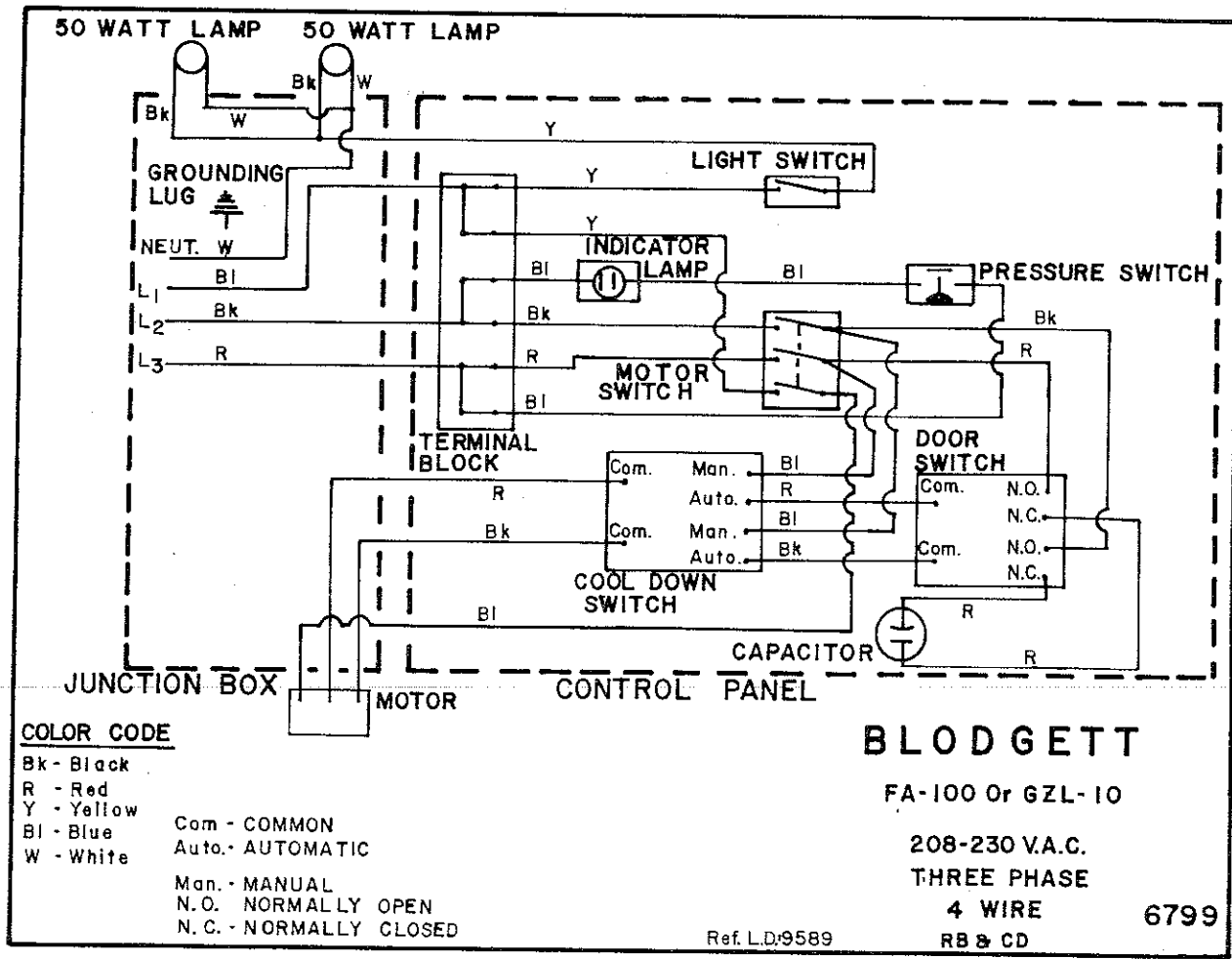
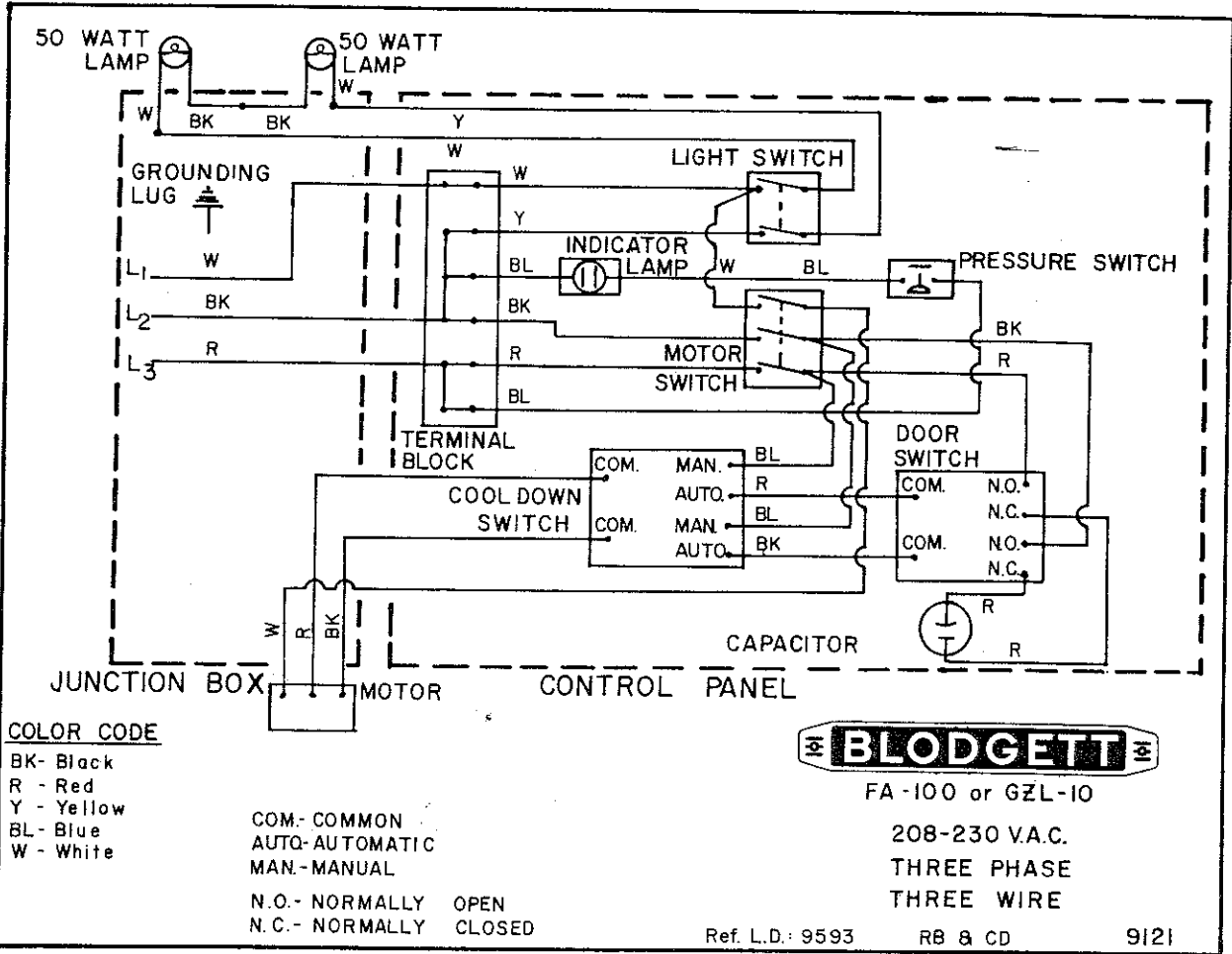

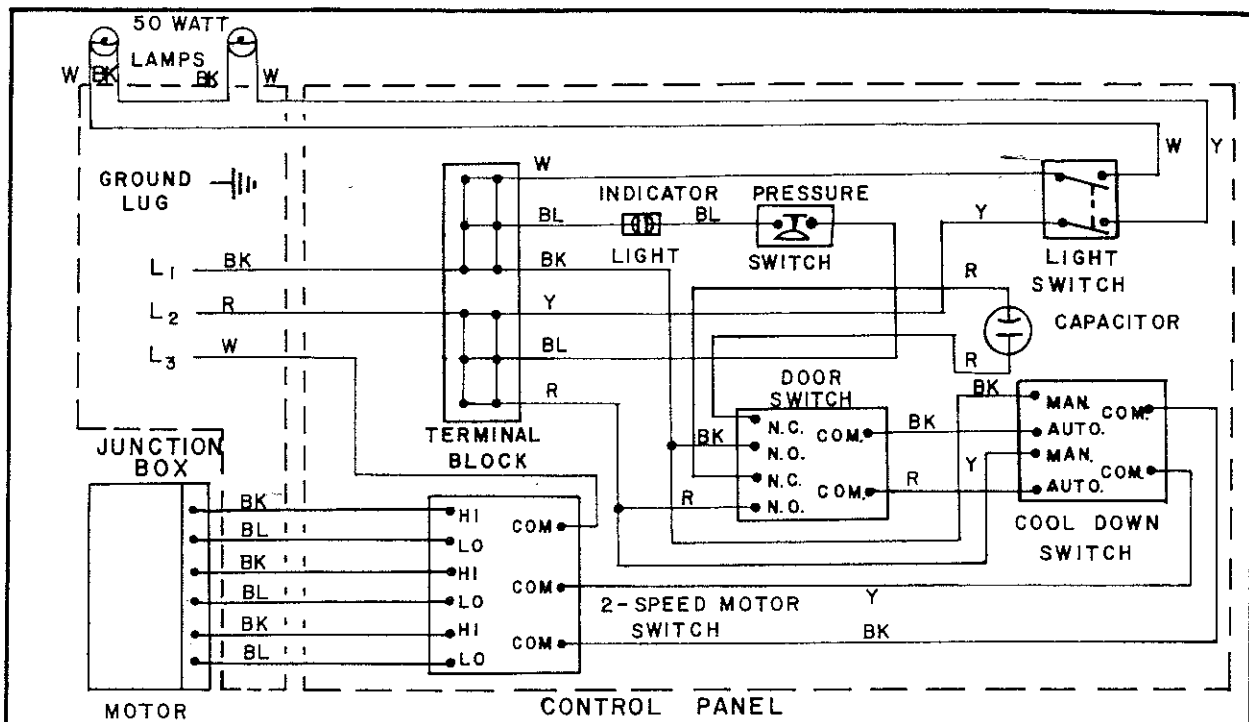

COLOR CODE

BK - BLACK
 R - RED
 O - ORANGE
 Y - YELLOW
 BL - BLUE
 W - WHITE

COM. COMMON
 N.O. NORMALLY OPEN
 N.C. NORMALLY CLOSED

BLODGETT

FA-100 or GZL-10
 208-230 V.A.C.
 THREE PHASE
 TWO SPEED

Ref L.D.: 9591 RB & CD 7427

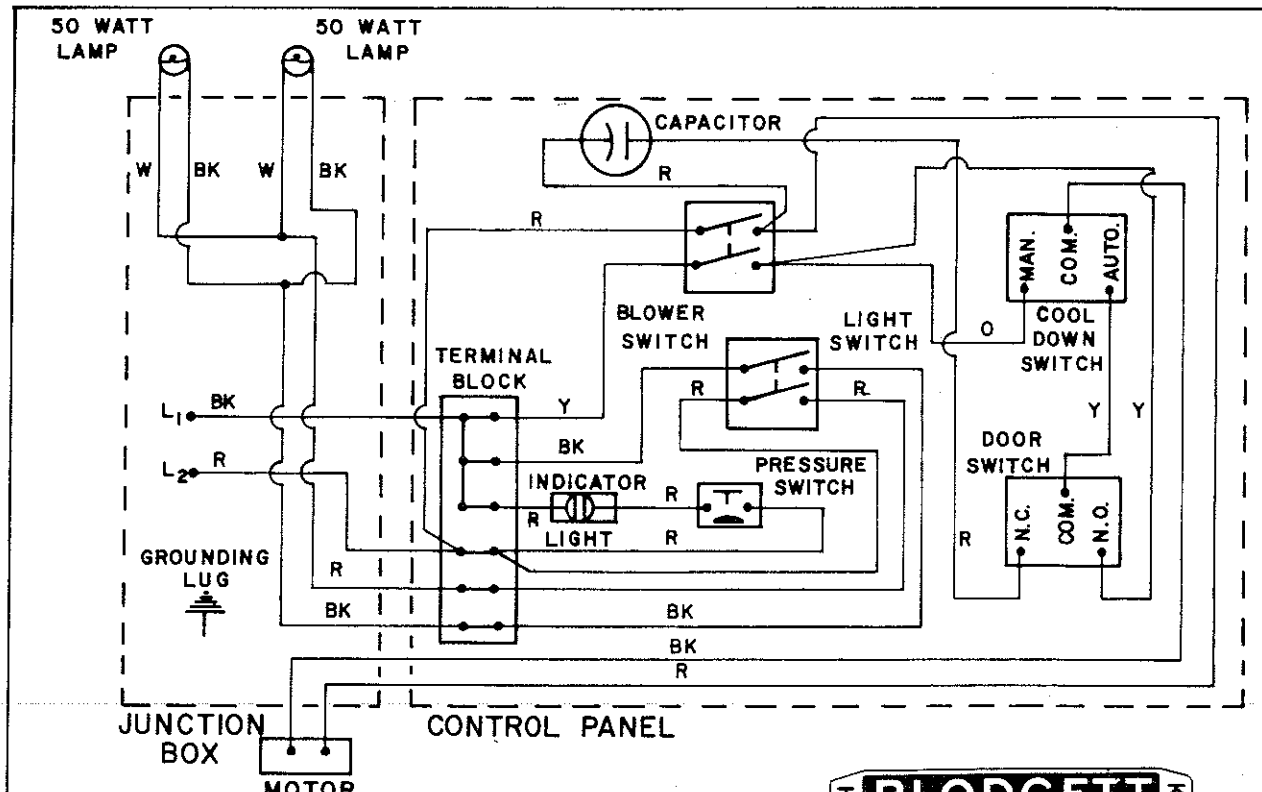

COLOR CODE

BK - BLACK
 R - RED
 O - ORANGE
 Y - YELLOW
 BL - BLUE
 W - WHITE

MAN. MANUAL
 COM. COMMON
 N.O. NORMALLY OPEN
 N.C. NORMALLY CLOSED
 AUTO. AUTOMATIC



FA-100 Or GZL-10
 208-230 V.A.C.
 SINGLE PHASE
 W/220 VOLT BULBS
 RB & CD

7760



*IMPORTANT:
THIS IS YOUR SPANNER KEY
PLEASE SAVE FOR FUTURE USE*

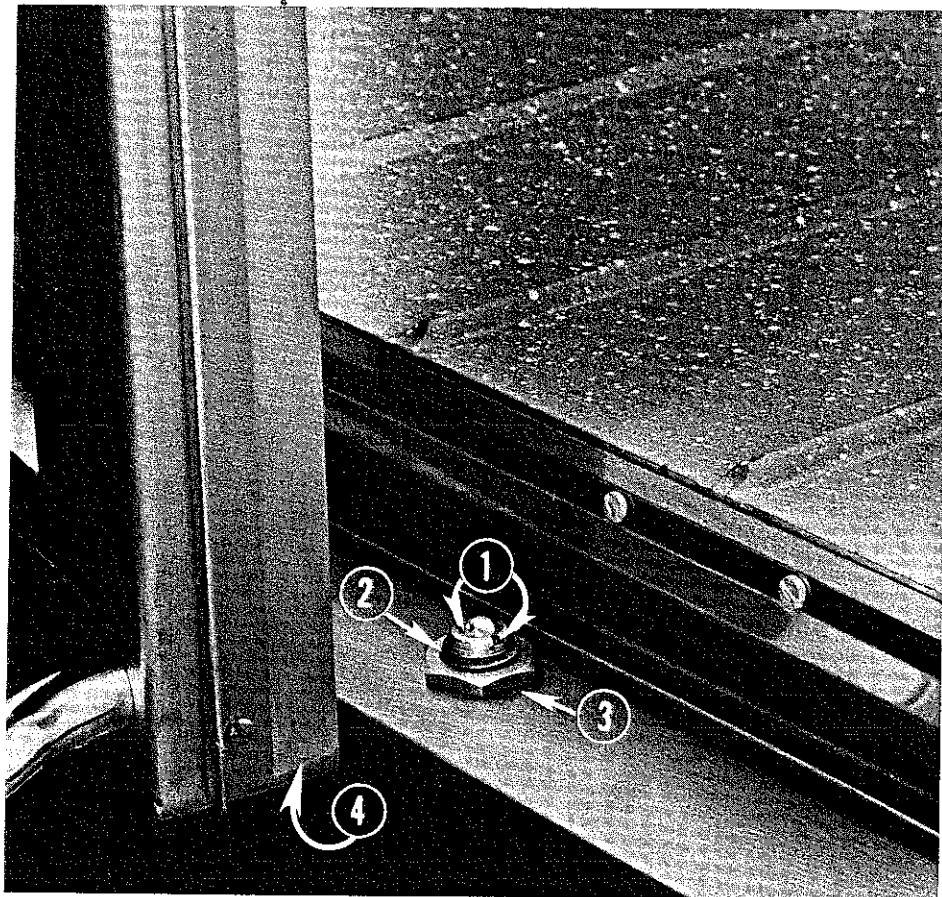

To adjust the ball plunger catch, insert spanner key (supplied above) in notches (1) on both sides of ball plunger (2) located in bottom center of doorway (shown above) and loosen jam nut (3) with 7/8" wrench. Adjust ball plunger by turning left or right with spanner key until plunger engages in striker plate on bottom side door (4) for best operation. With spanner key still inserted in ball plunger notches, tighten jam nut with wrench and oven door is ready for normal operation.

FA/GZL SERIES

	BTU	Spec. Gravity	W.C. Pressure
<input type="checkbox"/> Nat. Gas	1050	.63	4.8" ★
<input type="checkbox"/> Propane Gas	2550	1.53	11"
<input type="checkbox"/> Propane Gas	2550	1.53	10" ★

★ Supplied with pressure regulator.

Model	BTU	Main Burner Orifice	
		NAT	LP
FA-100 -----	85,000 BTU (42,500 per burner)	32	51
FA-102 -----	170,000 BTU (42,500 per burner)	32	51
GZL-10 -----	100,000 BTU (50,000 per burner)	30	49
GZL-20 -----	200,000 BTU (50,000 per burner)	30	49

Main Burner Port Diameter for all gases is 48 MTD.

The Safety Pilot Orifices are set as follows:

Nat. Gas .018

LP Gas .010

ORIGINAL EQUIPMENT WARRANTY

The G. S. Blodgett Company warrants to the original user its electrically-heated or gas-fired ovens to be free from defects in material and workmanship for which it is responsible. The Company's obligation under this warranty shall be limited to replacing without charge any part found to be defective and expense incurred (labor and material) for its installation for a period of ninety (90) days from date of shipment from the factory.

The G. S. Blodgett Company agrees to pay any recognized kitchen equipment service agency within the Continental United States for any labor required to repair or replace at our option any part which proves to be defective due to defects in material or workmanship during the warranty period. This warranty does include travel time not to exceed 2 hours and mileage not to exceed 50 miles.

This warranty does not cover any defect due to or resulting from handling, abuse, misuse, or harsh chemical action, nor shall it extend to any unit from which the serial number has been removed or altered, or modifications made by unauthorized service personnel or damage by flood, fire or other acts of God. Adjustments such as calibrations, leveling, tightening of fasteners or plumbing connections normally associated with original installation are the responsibility of the dealer or installer and not that of the Corporation.

The Corporation shall not be liable, directly or indirectly, under any circumstances for consequential or incidental damages, including, but not limited to: (i) any loss of business or profits; and (ii) labor, material or other charges, claims, losses or damages incurred or suffered from, in connection with or in consequences of the working upon, alteration, or repair of any such defective products or parts by persons or firms other than the Corporation.

