



MODEL MARK V

Full Size Electric Convection Oven



Project _____

Item No. _____

Quantity _____

Standard depth baking compartment - accepts five 18" x 26" standard full-size baking pans in left-to-right positions.

All data is shown per oven section, unless otherwise indicated.

Refer to operator manual specification chart for listed model name.

EXTERIOR CONSTRUCTION

- Full angle-iron frame
- Stainless steel front, top and sides
- Dual pane thermal glass windows encased in stainless steel door frames
- Porcelain door handle with simultaneous door operation
- Triple-mounted pressure lock door design with turnbuckle assembly
- Modular slide out front control panel for easy access
- Solid mineral fiber insulation at top, back, sides and bottom

INTERIOR CONSTRUCTION

- Double-sided porcelainized baking compartment liner (14 gauge) for easy cleaning
- Aluminized blower wheel
- Five chrome-plated racks, eleven rack positions with a minimum of 1-5/8" (41mm) spacing
- Interior lights

OPERATION

- Three tubular heaters
- Solid state thermostat with temperature control range of 200°F (93°C) to 500°F (260°C)
- Two speed fan motor
- 1/3 horsepower blower motor with automatic thermal overload protection
- Control area cooling fan
- Two halogen oven lamps

STANDARD FEATURES

- Solid state manual control with separate dials to control thermostat and timer
- 25" (635mm) adjustable stainless steel legs (for single units)
- 6" (152mm) adjustable stainless steel legs (for double sections)
- Three year oven parts and labor warranty* **
- Five year limited oven door warranty**

* Certain exclusion may apply. Contact factory for details

** For all international markets, contact your local distributor.

OPTIONS AND ACCESSORIES

(AT ADDITIONAL CHARGE)

- **Control options:**
 - Pulse Plus®
 - Cook & hold
 - Solid state digital control with LED display, cook and hold, and Pulse Plus®
 - Blodgett IQ2® multi-stage programmable control
- **Legs/casters/stands:**
 - 6" (152mm) seismic legs
 - 6" (152mm) casters
 - 4-1/4" (108mm) low profile casters (double only)
 - 25" (635mm) stainless steel open stand with rack guides
- Stainless steel oven liner
- Extra oven racks
- Solid stainless steel back
- 440 volt, 3 phase
- 480 volt, 3 phase
- Prison package (includes security control panel and stainless steel back)
- Security control panel
- Vent connector

OPTIONS AND ACCESSORIES

(AT NO CHARGE)

- Solid stainless steel doors



BLODGETT OVEN COMPANY

www.blodgett.com

44 Lakeside Avenue, Burlington, VT 05401

Phone: (802) 658-6600 • Fax: (802) 864-0183



MODEL MARK V

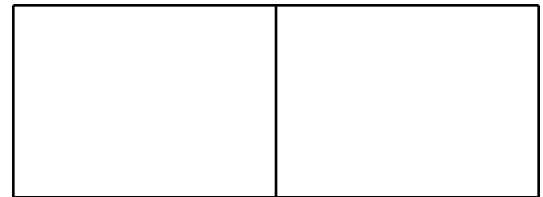

APPROVAL/STAMP

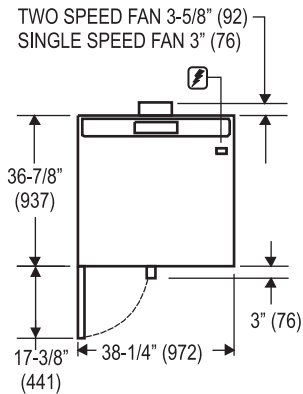

TOP VIEW

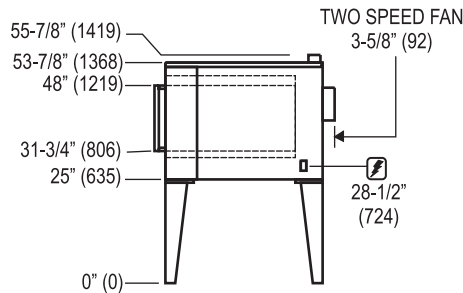

SINGLE

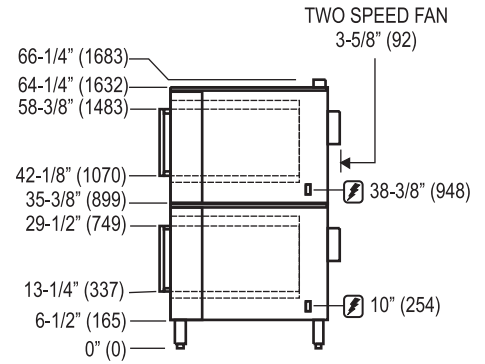

DOUBLE

Dimensions are in inches (mm)

SHORT FORM SPECIFICATIONS

Provide Blodgett full-size convection oven model MARK V, (single/double) compartment. Each compartment shall have (porcelainized/stainless) steel liner and shall accept five 18" x 26" standard full-size bake pans. Doors shall (be solid stainless steel/ have dual pane thermal glass windows) with single porcelain handle and simultaneous operation. Unit shall be electrically heated with three tubular heaters. Air in baking chamber distributed by single inlet blower wheel powered by a two-speed, 1/3 HP motor with thermal overload protection. Each chamber shall be fitted with two halogen lamps and five chrome-plated removable racks. Control panel shall be recessed with Cook/Cool Down mode selector, solid state (manual/digital) thermostat (200 - 500° F), (93-260°C) and 60-minute timer. Provide three year parts and labor warranty (check for exclusions). Provide options and accessories as indicated.

DIMENSIONS:

- Floor space** 38-1/4" (972mm) W x 36-7/8" (937mm) D
- Product clearance** 1/2" (12mm) from combustible and non-combustible construction
- Interior** 29" (737mm) W x 20" (508mm) H x 24-1/4" (616mm) D
- If oven is on casters add to all height dimensions:**
 - Single Add 4-1/2" (114mm) to all height dimensions
 - Double Height dimensions remain the same
 - Double Low Profile Subtract 2.5" (64mm) from all height dimensions

POWER SUPPLY:

V.A.C.	Hz	Phase	K.W.H.	Amperes (L1-L2-L3)
DOMESTIC				
208	60	1	11	51/0/51
208	60	3	11	31/29/29
220/240	60	1	11	44/0/44
220/240	60	3	11	26/24/24
440	60	3	11	15/14/14
480	60	3	11	14/13/13
1/3 H.P., 2 speed motor, 1140 and 1725 RPM (60Hz.)				

INTERNATIONAL

220/240	50	1	11	48/0/48
240/415	50	3	11	18/14/14
230/400	50	3	11	18/15/15

NOTE: The company reserves the right to make substitutions of components without prior notice.

MAXIMUM INPUT:

- Single 11KW
- Double 22KW (11KW each section)

MINIMUM ENTRY CLEARANCE:

- Uncrated 28-7/8" (733mm)
- Crated 34-1/16" (876mm)

SHIPPING INFORMATION:

Approx. Weight:

- Single 490 lbs. (222 kg)
- Double 1020 lbs. (463 kg)

Crate sizes:

- 37-1/2" (952mm) x 43-1/2" (1105mm) x 51-3/4" (1315mm)
- (2 crates required for double)

BLODGETT OVEN COMPANY

www.blodgett.com

44 Lakeside Avenue, Burlington, VT 05401 • Phone: (802) 658-6600 • Fax: (802) 864-0183