



XR8-G

Gas Mini Rotating Rack Bakery Oven

XR8-G ROTATING RACK OVEN

Project _____

Item No. _____

Quantity _____

Refer to operator manual specification chart for listed model names.



XR8-G with 12 pan stand

EXTERIOR CONSTRUCTION

- Fully welded angle iron frame
- Double pane tempered glass doors
- Semi-rigid mineral fiber insulation at top, back, sides and bottom
- Removable independent door design
- Control panel rotates out for easy access

INTERIOR CONSTRUCTION

- 304 stainless steel interior
- Rotating rack can be removed without tools
- Rack slide spacing can be adjusted without tools in any configuration using 1" increments.
- Stainless steel heat exchanger system
- Four side mounted halogen lights for superior illumination

OPERATION

- Indirect-fired with in-shot burners
- Internal steamer system
- Holds 8 pans (18" x 26") based on 4" adjustable slide spacing
- Digital programmable controls
- Separate bake and steam times
- Cool-down mode
- Blower delay
- Two speed, 3/4 horsepower, convection motor with automatic thermal overload protection

STANDARD FEATURES

- Pre-plumbed gas and water lines
- Two year parts and one year labor oven warranty*

* For all international markets, contact your local distributor.

OPTIONS AND ACCESSORIES

(AT ADDITIONAL CHARGE)

- **Gas hose with quick disconnect and restraining device:**
 - 48" (1219mm) hose
 - 36" (914mm) hose
- **Venting**
 - Draft diverter
 - Draft hood
- 12 pan stand with adjustable spacing, removeable crumb trays and low profile casters
- VFD control can hold multi-stage programming for up to 100 products
- Additional rack slides
- Wire rack for half-size pans



BLODGETT OVEN COMPANY

www.blodgett.com

44 Lakeside Avenue, Burlington, VT 05401 • Phone: (802) 658-6600 • Fax: (802) 864-0183



XR8-G Rotating Rack Oven

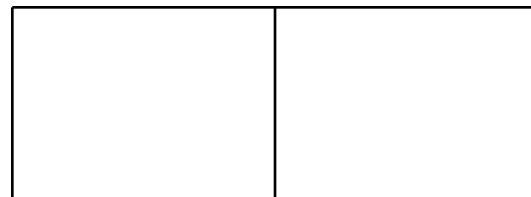

APPROVAL/STAMP

DIMENSIONS ARE IN INCHES (MM)

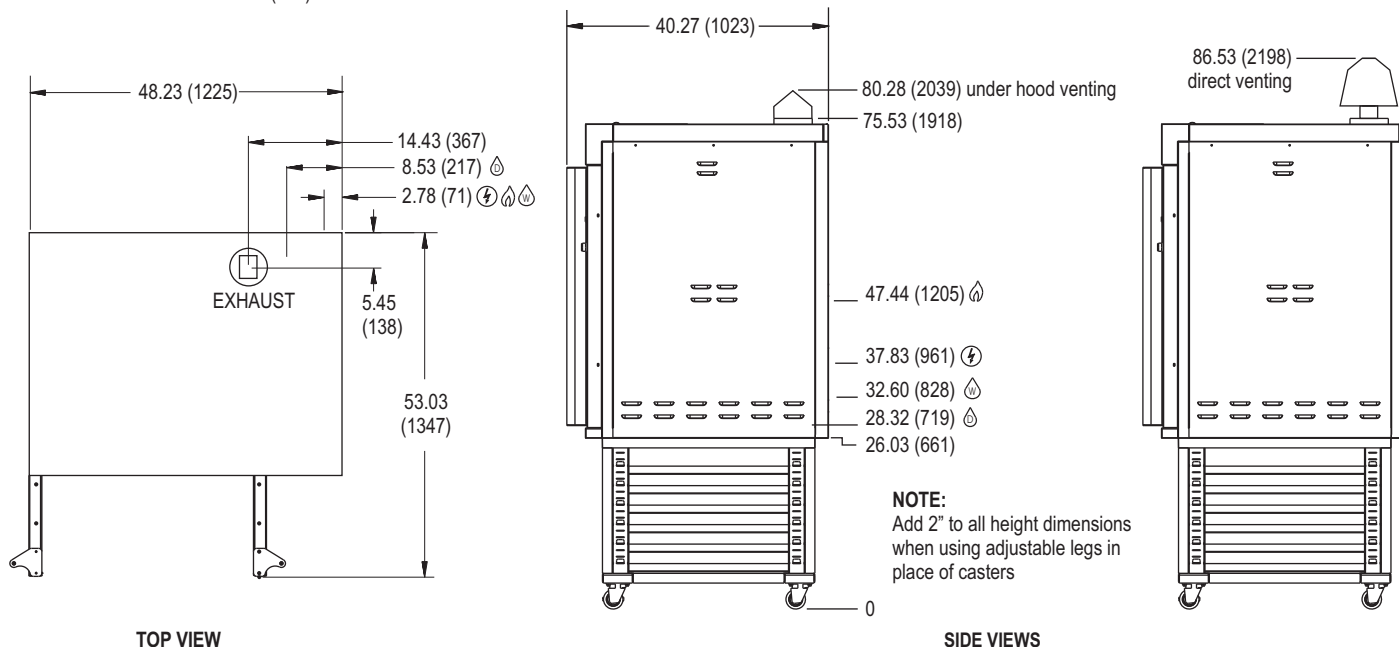

SHORT FORM SPECIFICATIONS

Provide Blodgett gas mini rotating rack bakery oven model XR8-G. Unit shall have a single compartment with fully welded angle iron frame, and 304 stainless steel interior. Unit shall accept eight 18" x 26" standard full-size bake pans and have rack slides with spacing that can be adjusted without tools in any configuration using 1" increments. Rotating rack shall be removable without tools. Unit shall have stainless steel front, top and sides. Doors shall be stainless steel, independent design with dual pane thermal glass windows. Unit shall be gas heated with electronic spark ignition and shall cook by means of indirect fired inshot burners. Unit shall have internal steamer system with pre-plumbed water lines. Unit shall be fitted with four side mounted, halogen lamps. Control panel shall be digital programmable controls, separate bake and steam times, cool-down mode, and blower delay. Manual gas service cut-off switch on front panel. Two year oven parts and one year labor warranty. Provide options and accessories as indicated.

DIMENSIONS:

Floor space 48.23" (1225 mm) W x 40.27" (1023 mm) D

Interior 32" (813 mm) W x 32" (813 mm) D

Product clearance

0" from combustible and non-combustible construction

GAS SUPPLY:

3/4" NPT

Manifold Pressure:

- Natural – 3.5" W.C.
- Propane – 10" W.C.

Inlet Pressure:

- Natural – 5.0" W.C. min. – 14.0" W.C. max.
- Propane – 11.0" W.C. min. – 14.0" W.C. max.

MAXIMUM INPUT:

XR8-G 110,000 BTU/hr

POWER SUPPLY:

XR8-G 120V, 60Hz, 1 phase, 15 amp maximum dedicated circuit

NOTE: The company reserves the right to make substitutions of components without prior notice

COLD WATER SUPPLY:

Pipe Size 3/4" GHT

Pressure 30-75 psi. (21-52 kPa) minimum

Flow Rate 1.12 gal/min (4.5 liters/min.)

Appliance is to be installed with backflow protection in accordance with Federal, State or Local codes.

DRAIN:

XR8-G 3/4" NPT rear drain connection

MINIMUM ENTRY CLEARANCE:

Uncrated* 33" (838 mm)

Crated 49.25" (1251mm)

* Unit will fit through standard 36" door with the doors, control panel, and back panel removed.

SHIPPING INFORMATION:

Approx. Weight:

XR8-G 950 lbs. (431 kg)

Stand 175 lbs. (79 kg)

Crate sizes:

XR8-G 49.25" (1251mm) x 54.25" (1378mm)

Stand 54" (1371mm) x 34" (864mm) x 28" (711mm)

BLODGETT OVEN COMPANY

www.blodgett.com

44 Lakeside Avenue, Burlington, VT 05401 • Phone: (802) 658-6600 • Fax: (802) 864-0183