



# KLT-G Gas Floor Model Tilting Kettle



### OPTIONS AND ACCESSORIES (AT ADDITIONAL CHARGE)

- **Faucets**
  - Single pantry faucet with swing spout
  - Double pantry faucet with swing spout
- **Draw Off valves and accessories**
  - 2" (50mm) draw off valve
  - 3" (76mm) draw off valve
  - 2" (50mm) dairy valve
  - 3" (76mm) dairy valve
  - Perforated strainer for draw off
  - Solid stainless steel disc for draw off valve
- **Etched markings**
  - Gallons
  - Litres
- Spring assist hinged stainless steel cover
- 316 stainless steel liner for 60 gallon models
- Triple basket assembly
- Graduated measuring strip
- Strainer hook
- Pour strainer
- Correctional package

Project \_\_\_\_\_

Item No. \_\_\_\_\_

Quantity \_\_\_\_\_

- Model KLT-20G - 20 gallon (76 litres) gas floor model tilting kettle
- Model KLT-40G - 40 gallon (151 litres) gas floor mode tilting kettle
- Model KLT-60G - 60 gallon (227 litres) gas floor mode tilting kettle

### CONSTRUCTION

- 304 stainless steel construction
- 2/3 jacketed with factory sealed distilled water enclosure
- Hemispherical design on bottom of kettle for superior heat circulation
- Drip proof stainless steel console
- Legs fitted with two hole adjustable flanged feet for securing to floor
- Self-locking tilt mechanism with trunnions connected to the gear and control consoles permit the kettle to tilt forward 90° for emptying
- Stainless steel control housing
- 316 stainless steel liner for 20 and 40 gallon models
- High efficiency power burner system

### OPERATION

- Integrally mounted controls
- Power switch
- Pressure switch
- Direct immersion thermostat
- Water sight glass
- Cook indicator light
- Pressure gauge
- Low water light
- Low water shut off
- Pressure relief valve
- 165-275°F (74-135°C) temperature range

### STANDARD FEATURES

- Manual control
- Stainless steel faucet bracket
- 120 VAC, 1 phase, 60 Hz
- One year parts and labor warranty\*

\* For all international markets, contact your local distributor.



KLT-G FLOOR MODEL TILTING KETTLE

**BLODGETT**

[www.blodgett.com](http://www.blodgett.com)

44 Lakeside Avenue, Burlington, VT 05401 • Phone: (802) 658-6600 • Fax: (802) 864-0183



# KLT-G FLOOR MODEL TILTING KETTLE



APPROVAL/STAMP

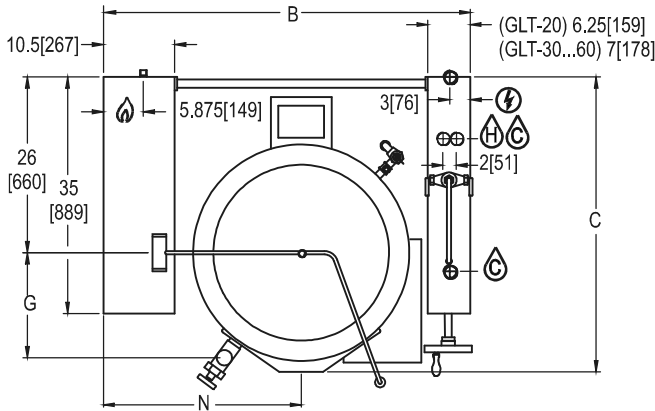

DIMENSIONS ARE IN INCHES [MM]

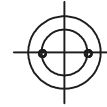

**FLANGED FOOT DETAIL**  
2 EQUALLY SPACED  
Ø7/16" [11mm] HOLES  
ON 2.5 [63] B.C.

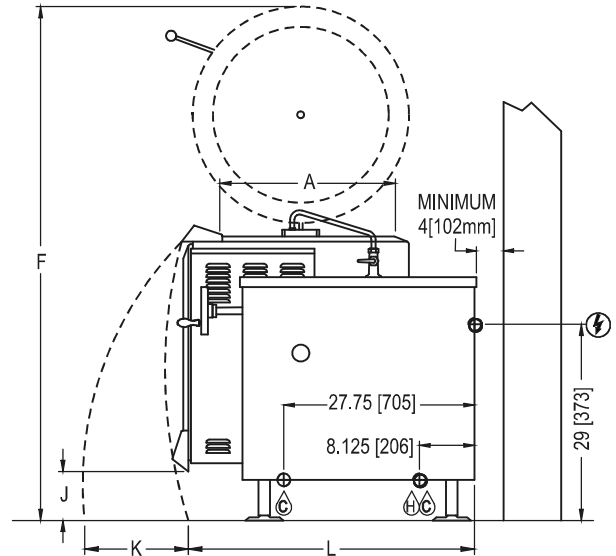
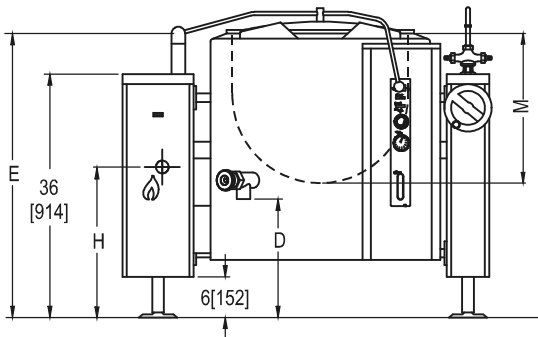

MODEL	A	B	C	D	E	F	G	H	J	K	L	M	N
KLT-20G	20[508]	48.13[1222]	40.63[1032]	19[483]	40.13[1019]	76.5[1943]	16.5[419]	24[610]	11[279]	22[559]	40.5[1029]	18.38[467]	25.5[648]
KLT-40G	26[660]	55.25[1403]	43.63[1108]	16.5[419]	43.25[1099]	76[1930]	15.5[394]	22.25[565]	7.5[191]	23[584]	42.5[1080]	22.13[562]	28.5[724]
KLT-60G	30[762]	59[1499]	45.63[1159]	17.88[454]	43.88[1115]	82[2083]	19.5[495]	22.25[565]	5.5[140]	23[584]	45.5[1156]	24.75[629]	30.5[775]

## SHORT FORM SPECIFICATIONS

Provide Blodgett model KLT-20G (20 gallon), KLT-40G (40 gallon) or KLT-60G (60 gallon) gas fired tri-leg tilting kettle. The unit shall have a double wall interior to form a steam jacket around the lower 2/3 of the kettle. The jacket enclosure shall contain distilled water which is factory sealed. The bottom of the kettle shall be of hemispherical design for superior heat circulation. The console shall be drip proof, stainless steel clad and shall be mounted on 6" removable legs fitted with two hole adjustable flanged feet for securing to floor. The unit shall pivot on trunnions connected to the tilt mechanism and the outboard bearing connected to the gear and control consoles and shall permit the kettle to tilt forward a full 90° for complete emptying. The tilt mechanism shall be self locking for positive stop action. Construction shall be of all welded satin finish 304 stainless steel. The controls shall be integrally mounted and shall include a power switch, direct immersion thermostat water site glass with range of 165-275°F (74-135°C), a cook indicator light, pressure gauge, pressure relief valve, low water light and low water shut off. Unit shall be ASME code stamped and National Board registered. Provide options and accessories as indicated.

## MAXIMUM INPUT:

KLT-20G 80,000 BTU  
KLT-40G 100,000 BTU  
KLT-60G 120,000 BTU

## GAS SUPPLY:

3/4" IPS supply line required

## Minimum Inlet Pressure:

Natural 6.0" W.C. static to unit  
Propane 11.0" W.C. static to unit

## POWER SUPPLY:

120VAC, 1 phase, 60 Hz., 2-wire w/ground

## SHIPPING INFORMATION:

### Approx. Weight:

KLT-20G 750 lbs. (340 kg)  
KLT-40G 980 lbs. (444 kg)  
KLT-60G 1195 lbs. (542 kg)

**NOTE:** The company reserves the right to make substitutions of components without prior notice.

**BLODGETT**

[www.blodgett.com](http://www.blodgett.com)

44 Lakeside Avenue, Burlington, VT 05401 • Phone: (802) 658-6600 • Fax: (802) 864-0183