



BLT-G

Gas Floor Model Braising Pan
with Manual Tilt



OPTIONS AND ACCESSORIES

(AT ADDITIONAL CHARGE)

- **Faucets**
 - Single pantry faucet with swing spout
 - Double pantry faucet with swing spout
- **Etched markings**
 - Gallons
 - Litres
- **Draw off valves**
 - 2" (50mm) draw off valve
 - 3" (76mm) draw off valve
- 220 VAC, 1 phase, 60 Hz
- Pan carrier
- Steam pan insert
- Correctional package

Project _____

Item No. _____

Quantity _____

- Model BLT-30G (30 gallon electric braising pan with manual tilt)
- Model BLT-40G (40 gallon electric braising pan with manual tilt)

CONSTRUCTION

- #4 finish 10 gauge stainless steel pan with polished interior
- Coved corners
- 5/8" thick stainless steel clad plate
- Side trunnions connected to gear and control consoles for tilting
- Welded stainless steel tubular legs with bullet feet on front legs and flanged adjustable feet on back legs

OPERATION

- Integrally mounted controls
- Ignition indicator light
- Power switch
- Thermostat
- Cook indicator light
- High temperature cut-off
- 100-450°F (38-232°C) temperature range

STANDARD FEATURES

- Spring assist hinged stainless steel cover with handle
- No drip condensate guide
- Removable pour strainer
- Manual control
- 120 VAC, 1 phase, 60 hz
- One year parts and labor warranty*

* For all international markets, contact your local distributor.



BLT-G BRAISING PAN WITH MANUAL TILT

BLODGETT

www.blodgett.com

44 Lakeside Avenue, Burlington, VT 05401 • Phone: (802) 658-6600 • Fax: (802) 864-0183



BLT-G GAS BRAISING PAN W/MANUAL TILT



APPROVAL/STAMP

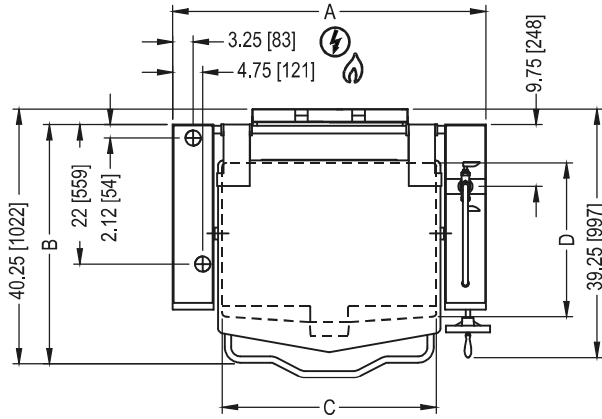

REAR FLANGED FOOT DETAIL
 4 EQUALLY SPACED
 Ø7/16" [11mm] HOLES
 ON 3 [76] B.C.

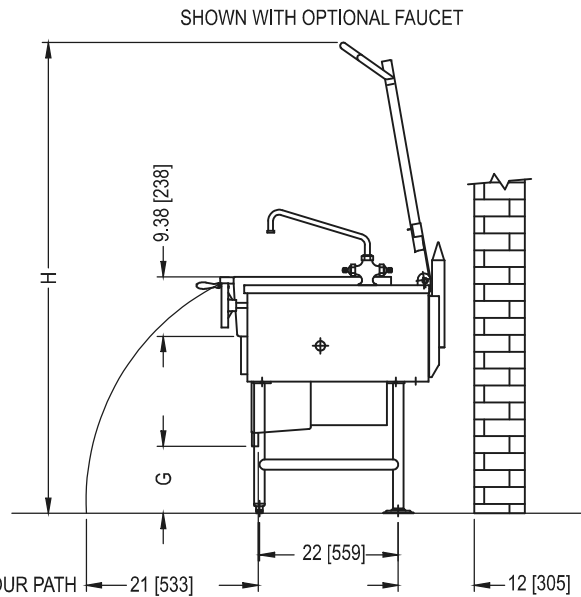
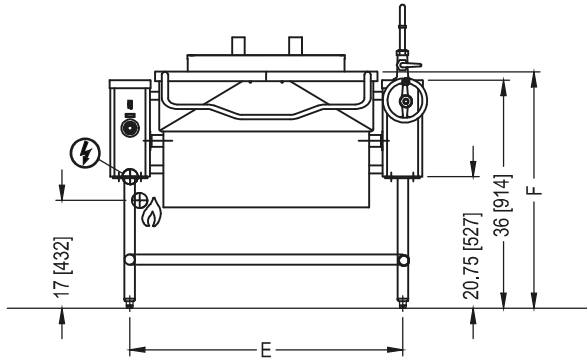

DIMENSIONS ARE IN INCHES [MM]

POUR PATH ← 21 [533] →

MODEL	A	B	C	D	E	F	G	H
BLT-30G	49.5[1257]	37.25[959]	33.5[851]	24[610]	43.13[1095]	37.25[946]	10.5[267]	74.25[1886]
BLT-40G	58.5[1486]	38.88[988]	43.5[1105]	24[610]	51.75[1314]	37.25[946]	10.5[267]	74.25[1886]

SHORT FORM SPECIFICATIONS

Provide Blodgett model BLT-30G, 30 gallon (114 litre) or BLT-40G (152 litre) gas braising pan with manual tilt. The unit shall have a one-piece covered corner, 10 gauge stainless steel pan with #4 exterior finish and polished interior. Cooking surface shall be 5/8" thick stainless clad plate ensuring even heat transfer over entire cooking surface. Pan shall pivot on side trunnions connected to the gear and control consoles. The consoles shall be drip proof, stainless steel clad and shall be supported by an all welded 1-5/8" (41mm) stainless steel pipe frame with front legs fitted with adjustable bullet feet and rear legs fitted with flange adjustable feet for securing to the floor. The worm and gear tilt mechanism shall allow the pan to tilt forward manually for complete emptying of contents. The controls shall be integrally mounted in the right hand console and shall include a power switch, thermostat with range of 100-450°F (38-232°C), a cook indicator light, ignition indicator light, and high temperature cut-off. Provide options and accessories as indicated.

MAXIMUM INPUT:

BLT-30G 80,000 BTU/hr
 BLT-40G 100,000 BTU/hr

POWER SUPPLY:

120VAC, 1 phase, 60 Hz., 2-wire w/ground
 6' (1.8m) electric cord set furnished.

GAS SUPPLY:

1/2" IPS supply line required

Minimum Inlet Pressure:

Natural 7.0" W.C. static to unit
 Propane 11.0" W.C. static to unit

SHIPPING INFORMATION:

Approx. Weight:

BLT-30G 630 lbs. (286 kg)
 BLT40G 740 lbs. (336 kg)

NOTE: The company reserves the right to make substitutions of components without prior notice.

BLODGETT

www.blodgett.com

44 Lakeside Avenue, Burlington, VT 05401 • Phone: (802) 658-6600 • Fax: (802) 864-0183