

BUNN®

CWT-CS ***CWTF-CS***

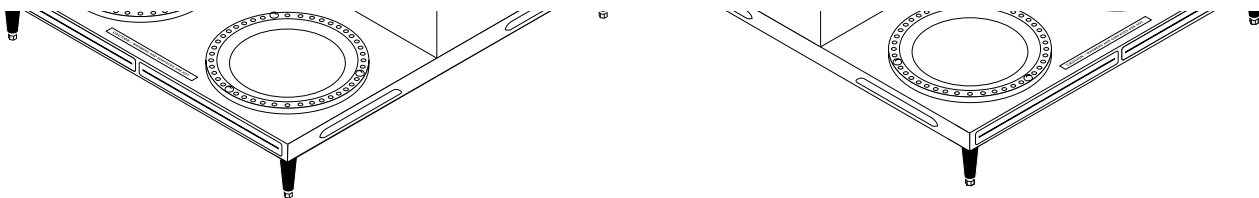

DISCONTINUED VERSION
Parts listed in this catalog
may no longer be available.



ILLUSTRATED PARTS CATALOG

Designs, materials, weights, specifications, and dimensions for equipment or replacement parts are subject to change without notice.

BUNN-O-MATIC CORPORATION

POST OFFICE BOX 3227

SPRINGFIELD, ILLINOIS 62708-3227

PHONE: (217) 529-6601 FAX: (217) 529-6644

BUNN-O-MATIC COMMERCIAL PRODUCT WARRANTY

Bunn-O-Matic Corp. ("BUNN") warrants equipment manufactured by it as follows:

- 1) All equipment other than as specified below: 2 years parts and 1 year labor.
- 2) Electronic circuit and/or control boards: parts and labor for 3 years.
- 3) Compressors on refrigeration equipment: 5 years parts and 1 year labor.
- 4) Grinding burrs on coffee grinding equipment to grind coffee to meet original factory screen sieve analysis: parts and labor for 3 years or 30,000 pounds of coffee, whichever comes first.

These warranty periods run from the date of installation BUNN warrants that the equipment manufactured by it will be commercially free of defects in material and workmanship existing at the time of manufacture and appearing within the applicable warranty period. This warranty does not apply to any equipment, component or part that was not manufactured by BUNN or that, in BUNN's judgment, has been affected by misuse, neglect, alteration, improper installation or operation, improper maintenance or repair, damage or casualty. This warranty is conditioned on the Buyer 1) giving BUNN prompt notice of any claim to be made under this warranty by telephone at (217) 529-6601 or by writing to Post Office Box 3227, Springfield, Illinois 62708-3227; 2) if requested by BUNN, shipping the defective equipment prepaid to an authorized BUNN service location; and 3) receiving prior authorization from BUNN that the defective equipment is under warranty.

THE FOREGOING WARRANTY IS EXCLUSIVE AND IS IN LIEU OF ANY OTHER WARRANTY, WRITTEN OR ORAL, EXPRESS OR IMPLIED, INCLUDING, BUT NOT LIMITED TO, ANY IMPLIED WARRANTY OF EITHER MERCHANTABILITY OR FITNESS FOR A PARTICULAR PURPOSE. The agents, dealers or employees of BUNN are not authorized to make modifications to this warranty or to make additional warranties that are binding on BUNN. Accordingly, statements by such individuals, whether oral or written, do not constitute warranties and should not be relied upon.

If BUNN determines in its sole discretion that the equipment does not conform to the warranty, BUNN, at its exclusive option while the equipment is under warranty, shall either 1) provide at no charge replacement parts and/or labor (during the applicable parts and labor warranty periods specified above) to repair the defective components, provided that this repair is done by a BUNN Authorized Service Representative; or 2) shall replace the equipment or refund the purchase price for the equipment.

THE BUYER'S REMEDY AGAINST BUNN FOR THE BREACH OF ANY OBLIGATION ARISING OUT OF THE SALE OF THIS EQUIPMENT, WHETHER DERIVED FROM WARRANTY OR OTHERWISE, SHALL BE LIMITED, AT BUNN'S SOLE OPTION AS SPECIFIED HEREIN, TO REPAIR, REPLACEMENT OR REFUND.

In no event shall BUNN be liable for any other damage or loss, including, but not limited to, lost profits, lost sales, loss of use of equipment, claims of Buyer's customers, cost of capital, cost of down time, cost of substitute equipment, facilities or services, or any other special, incidental or consequential damages.

TABLE OF CONTENTS

Electrical and Operating Controls (Without Faucet)	18
Electrical and Operating Controls (With Faucet)	20
Faucet and Tubing	16
Fill Basin	8
Funnel	24
Hood, Trunk, Panels and Base (Without Faucet)	4
Hood, Trunk, Panels and Base (With Faucet)	6
Numerical Index	26
Strainer, Flow Control, Solenoid and Lines	14
Tank and Components (Without Faucet)	10
Tank and Components (With Faucet)	12
Warmer Assemblies	22

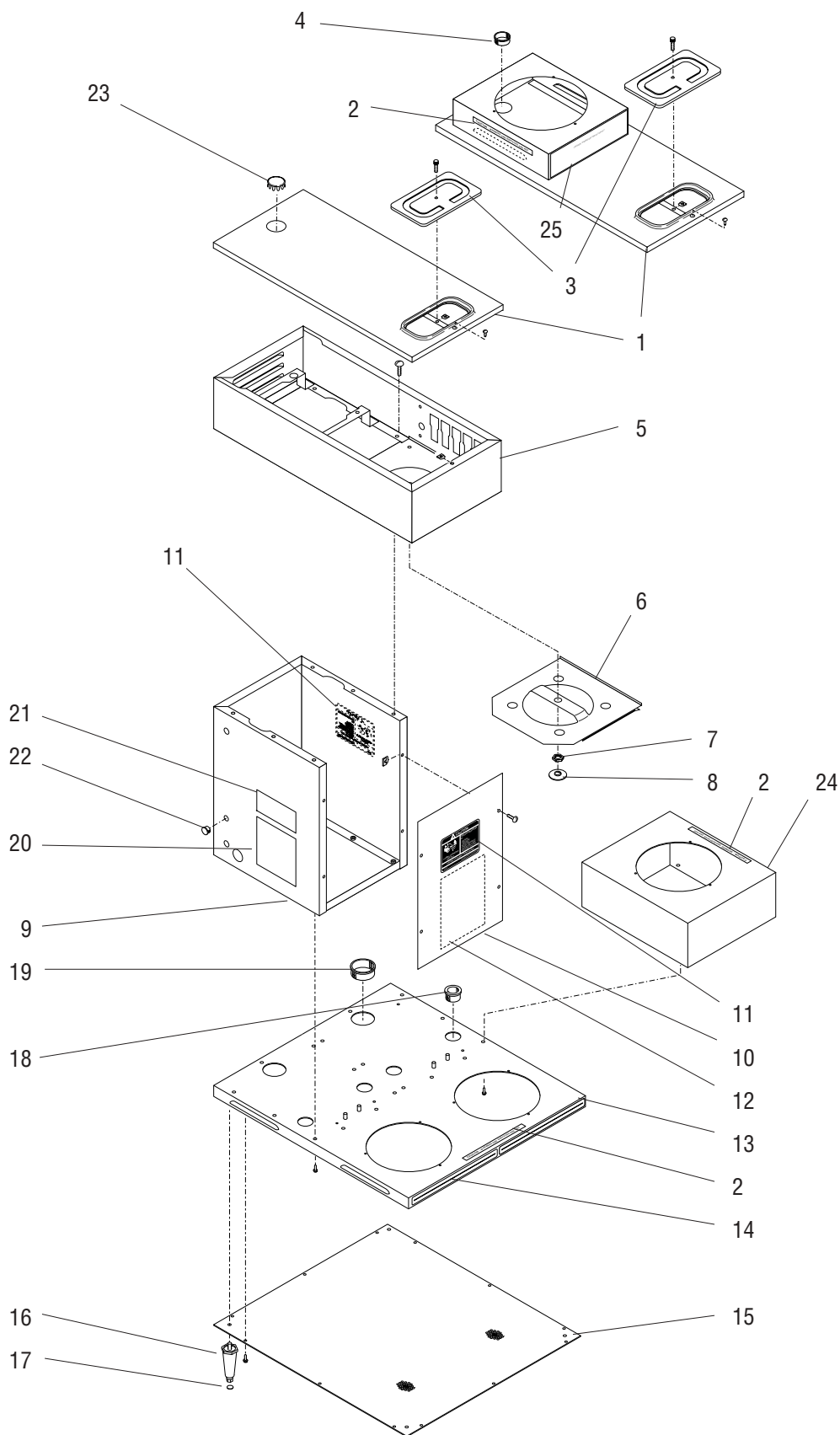

HOOD, TRUNK, PANELS AND BASE W/OUT FAUCET

ITEM	PART NO.	QTY.	DESCRIPTION
1	25310.0001	1	Cover, Top
	25633.0003	1	Cover, Top (Brewers W/ Top Warmer. Includes items 2, 4 & 25)
	01303.0000	1	Screw, Pan Head #4-40 x .50"
	00916.0000	1	Fastener, J-Type #4.40
2	12364.0000	4	Decal, Caution - Warmers and Surfaces Are Hot (Two less used on brewers without top warmer)
3	02722.0000	1	Lid, Pour-In
	01319.0000	1	Screw, Thumb #8-32 x .75"
	00912.0000	1	Fastener, J-Type #8-32
4	01592.0001	1	Bushing, Snap 1.188" Dia
5	13350.0013	1	Housing, Hood
	02308.0000	6	Screw, Pan Head #8-32 x .375"
6	13354.0000	1	Plate, Swivel W/Funnel Rails
7	-----	1	Nut (See Tank and Components)
8	-----	1	Sprayhead (See Tank and Components)
9	26513.0000	1	Trunk W/Decals (Includes Items 11, 20 thru 22)
10	25144.0004	1	Panel W/Decals (Includes items 11 & 12)
	01382.0000	4	Screw, Truss Head SST #6-32 x .375"
	00988.0000	4	Fastener, U-Type #6-32
11	00658.0000	2	Decal, Caution - Decanter/Funnel
12	10836.0000	1	Schematic, Electrical 120V & 120V/240V
13	25657.0000	1	Housing W/Decals, Base (Includes items 2 & 14)
	02308.0000	16	Screw, Pan Head #8-32 x .38"
14	22306.0000	2	Decal, Decorative Stripe
15	12667.0001	1	Cover, Base
	02332.0002	12	Screw, Hex-Crimptite #6 x .38"
16	03359.0001	4	Leg, 4" Adjustable BLK (Order item 26)
17	03993.0000	4	Pad, Anti-Skid, Rubber (.70" Dia.) (Order item 26)
18	01592.0000	2	Bushing, Snap 1" Dia.
19	01593.0000	2	Bushing, Snap 1.5" Dia.
20	00831.0000	1	Decal, Warning - Electrical
21	00656.0000	1	Decal, Comply To Plumbing Code
22	00670.0000	1	Plug, Hole - .437" Hole Dia
23	02999.0000	1	Plug, Hole 1.19" Dia (Early Models)
24	25658.0001	1	Housing W/Decals, Side Warmer (Includes item 2)
25	02765.0000	1	Decal, Caution - Surfaces and Warmers are Hot
26	13255.0005	-	Leg Kit (Includes items 16 & 17)

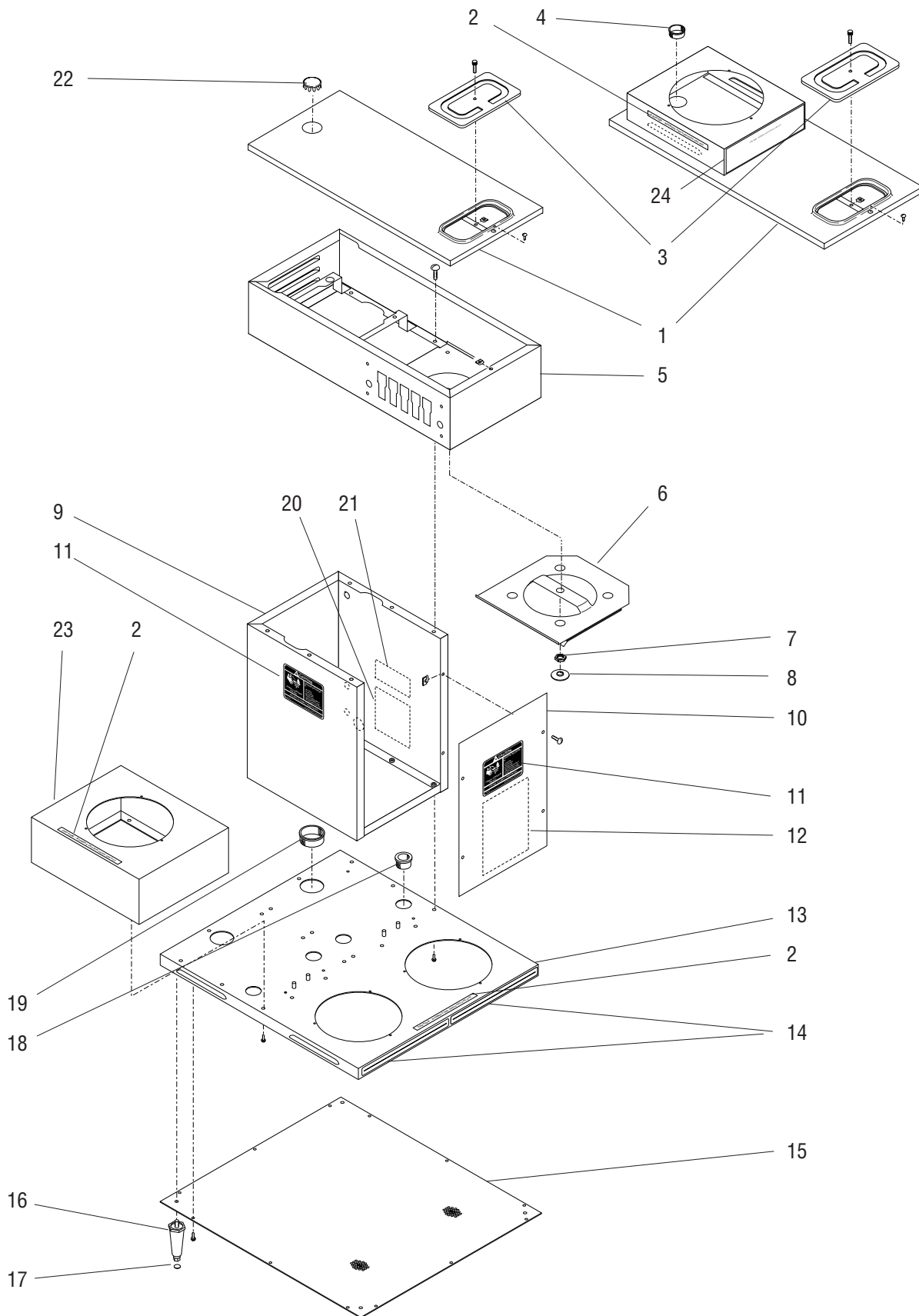

HOOD, TRUNK, PANELS AND BASE W/FAUCET

ITEM	PART NO.	QTY.	DESCRIPTION
1	25310.0001	1	Cover, Top
	25633.0003	1	Cover, Top (Brewers W/ Top Warmer. Includes items 2, 4 & 24)
	01303.0000	1	Screw, Pan Head #4-40 x .50"
	00916.0000	1	Fastener, J-Type #4.40
2	12364.0000	4	Decal, Caution - Warmers and Surfaces Are Hot (Two less used on brewers without top warmer)
3	02722.0000	1	Lid, Pour-In
	01319.0000	1	Screw, Thumb #8-32 x .75"
	00912.0000	1	Fastener, J-Type #8-32
4	01592.0001	1	Bushing, Snap 1.188" Dia
5	13350.0012	1	Housing, Hood
	02308.0000	6	Screw, Pan Head #8-32 x .375"
6	13354.0000	1	Plate, Swivel W/Funnel Rails
7	-----	1	Nut (See Tank and Components)
8	-----	1	Sprayhead (See Tank and Components)
9	26513.0001	1	Trunk W/Decals (Includes Items 11, 20 and 21)
10	25144.0004	1	Panel W/Decals (Includes items 11 & 12)
	01382.0000	4	Screw, Truss Head SST #6-32 x .375"
	00988.0000	4	Fastener, U-Type #6-32
11	00658.0000	2	Decal, Caution - Decanter/Funnel
12	10836.0000	1	Schematic, Electrical 120V & 120V/240V
13	25657.0000	1	Housing W/Decals, Base (Includes items 2 & 14)
	02308.0000	16	Screw, Pan Head #8-32 x .38"
14	22306.0000	2	Decal, Decorative Stripe
15	12667.0001	1	Cover, Base
	02332.0002	12	Screw, Hex-Crimptite #6 x .38"
16	03359.0001	4	Leg, 4" Adjustable BLK
17	03993.0000	4	Pad, Anti-Skid, Rubber (.70" Dia.)
18	01592.0000	2	Bushing, Snap 1" Dia.
19	01593.0000	2	Bushing, Snap 1.5" Dia.
20	00831.0000	1	Decal, Warning - Electrical
21	00656.0000	1	Decal, Comply To Plumbing Code
22	02999.0000	1	Plug, Hole 1.19" Dia (Early Models)
23	25658.0001	1	Housing W/Decals, Side Warmer (Includes item 2)
24	02765.0000	1	Decal, Caution - Surfaces and Warmers are Hot

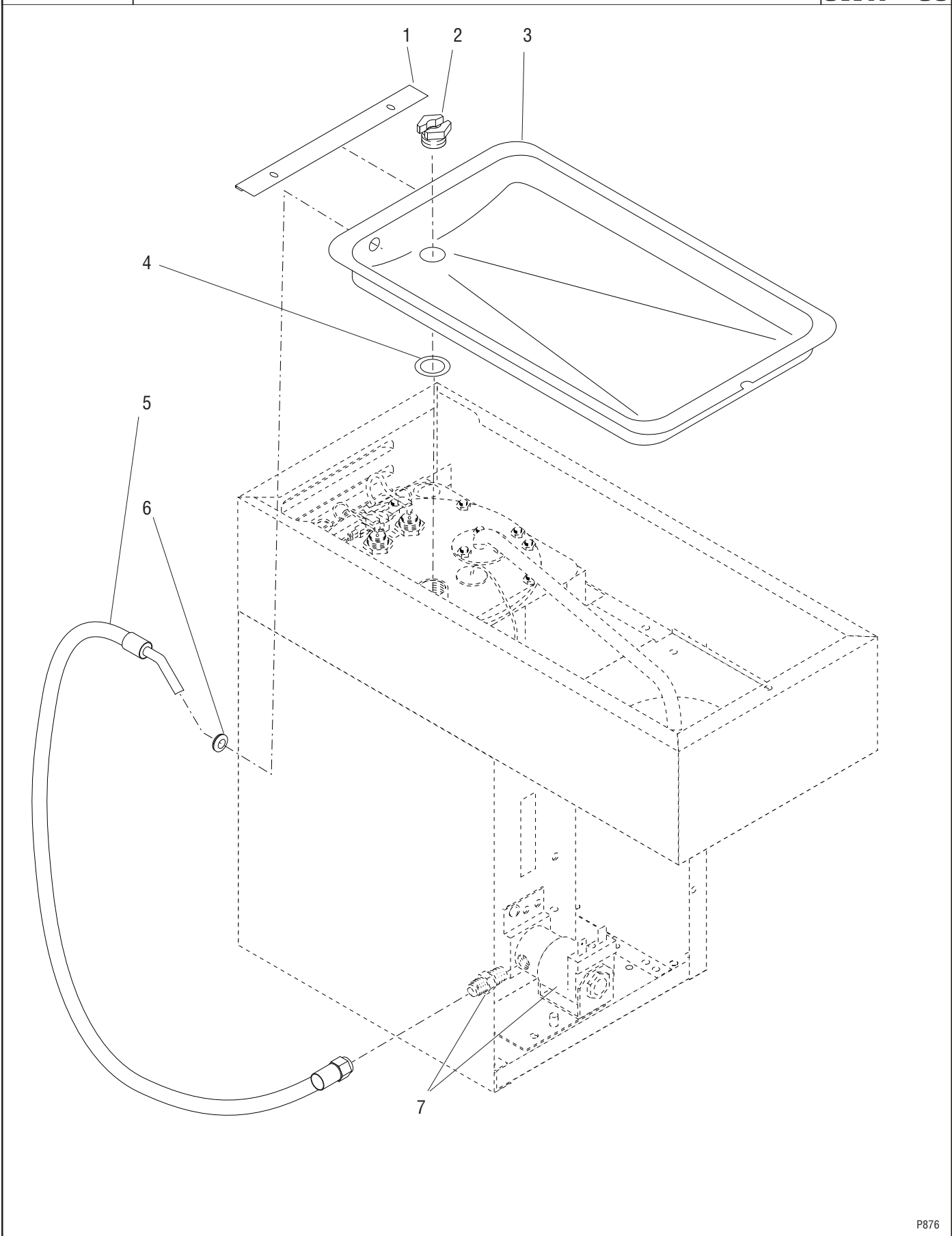

FILL BASIN

ITEM	PART NO.	QTY.	DESCRIPTION
1	11424.0000	1	Plate, Splash Guard
2	01212.0000	1	Fitting, Tank Inlet
3	04270.0002	1	Fill Basin
4	01201.0000	1	Gasket, Tank Inlet
5	12914.0002	1	Tube Assembly, Solenoid To Fill Basin (Includes item 6)
6	12928.0000	1	Grommet, Basin
7	-----	-	Solenoid (See STRAINER-FLOW CONTROL, SOLENOID & LINES)

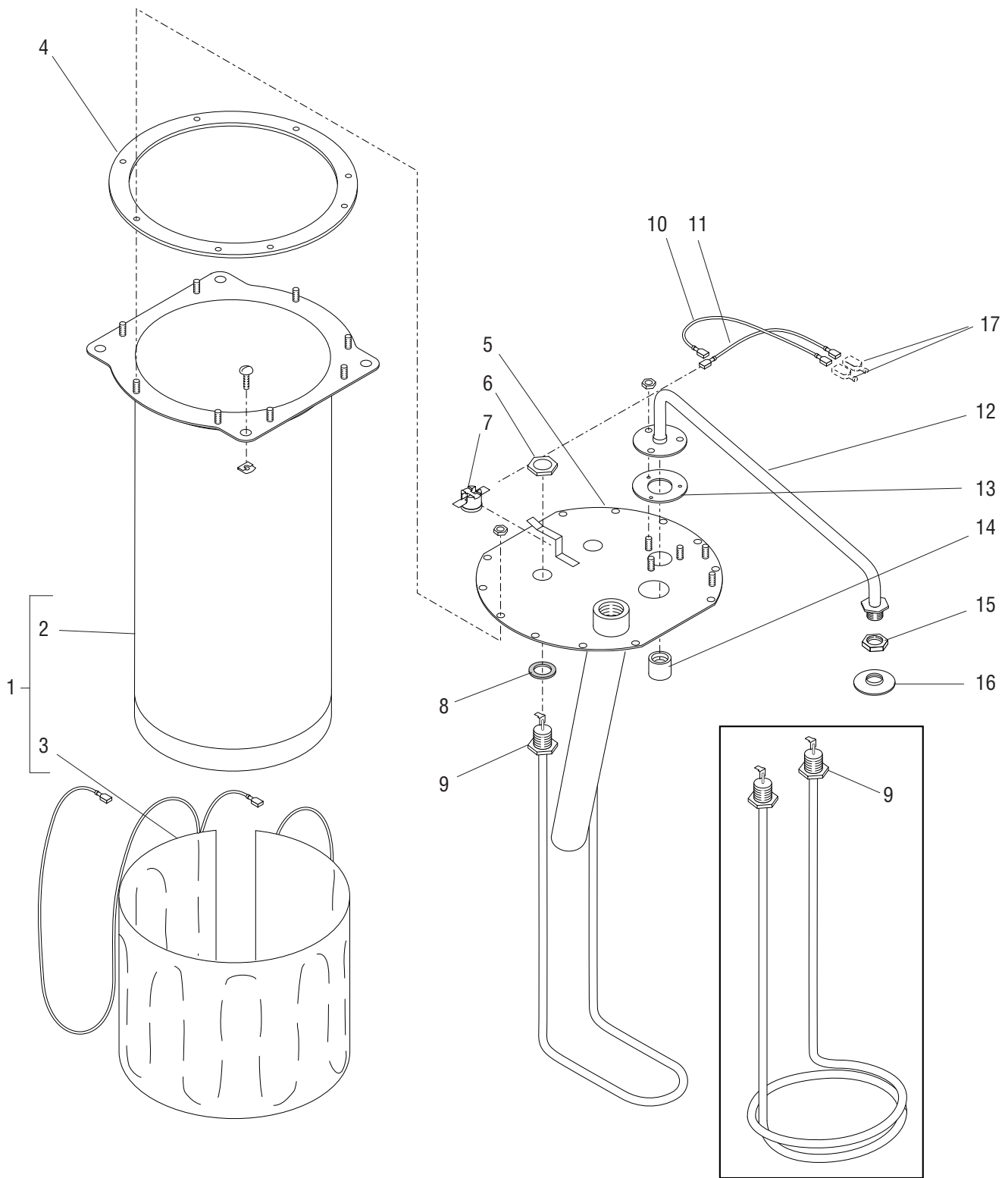

TANK AND COMPONENTS W/OUT FAUCET

ITEM	PART NO.	QTY.	DESCRIPTION
-	25319.1000	1	Tank Assy, 1320W 120V (Includes items 1 thru 14)
	25319.1001	1	Tank Assy, 1800W 120V (Includes items 1 thru 14)
	25319.1002	1	Tank Assy, 3500W 120/240V (Includes items 1 thru 14)
	01315.0000	2	Screw, Truss Head #8-32 x .3/8"
	00912.0000	2	Fastener, J-Type #8-32
1	04119.0000	1	Tank W/Blanket Warmer, 120V (Includes items 2 & 3)
2	04118.0000	1	Tank
3	04260.0000	1	Blanket Warmer, 50W 120V
4	04221.0000	1	Gasket, Tank Lid
5	25158.0002	1	Tank Lid Weldment
	00908.0000	8	Nut, Hex #8-32
6	00942.0000	2	Nut, Hex .50"-20
7	29329.1000	1	Thermostat, Limit
8	00943.0000	2	Gasket, Tank Heater
9	04236.1000	1	Tank Heater, 1320W 120V
	04636.1000	1	Tank Heater, 1800W 120V
	04637.1000	1	Tank Heater, 3500W 240V
			} Includes item 8
10	23769.0000	1	Lead, Electrical BLK (Thermostat to Heater)
11	23768.0000	1	Lead, Electrical BLU(Thermostat to Limit)
12	11431.0002	1	Sprayhead Tube Kit (Includes 3 mounting nuts below & items 13 & 14)
	00908.0000	3	Nut, Hex #8-32
13	05515.0000	1	Gasket, Sprayhead Tube
14	05518.0000	1	Hub, Syphon
15	01075.0000	1	Nut, Hex .438" - 20
16	01082.0007	1	Sprayhead, 1-Hole (Brewers with Pouch-Pack Funnel)
17	-----	-	Thermostat Leads (See Electrical and Operating Controls)

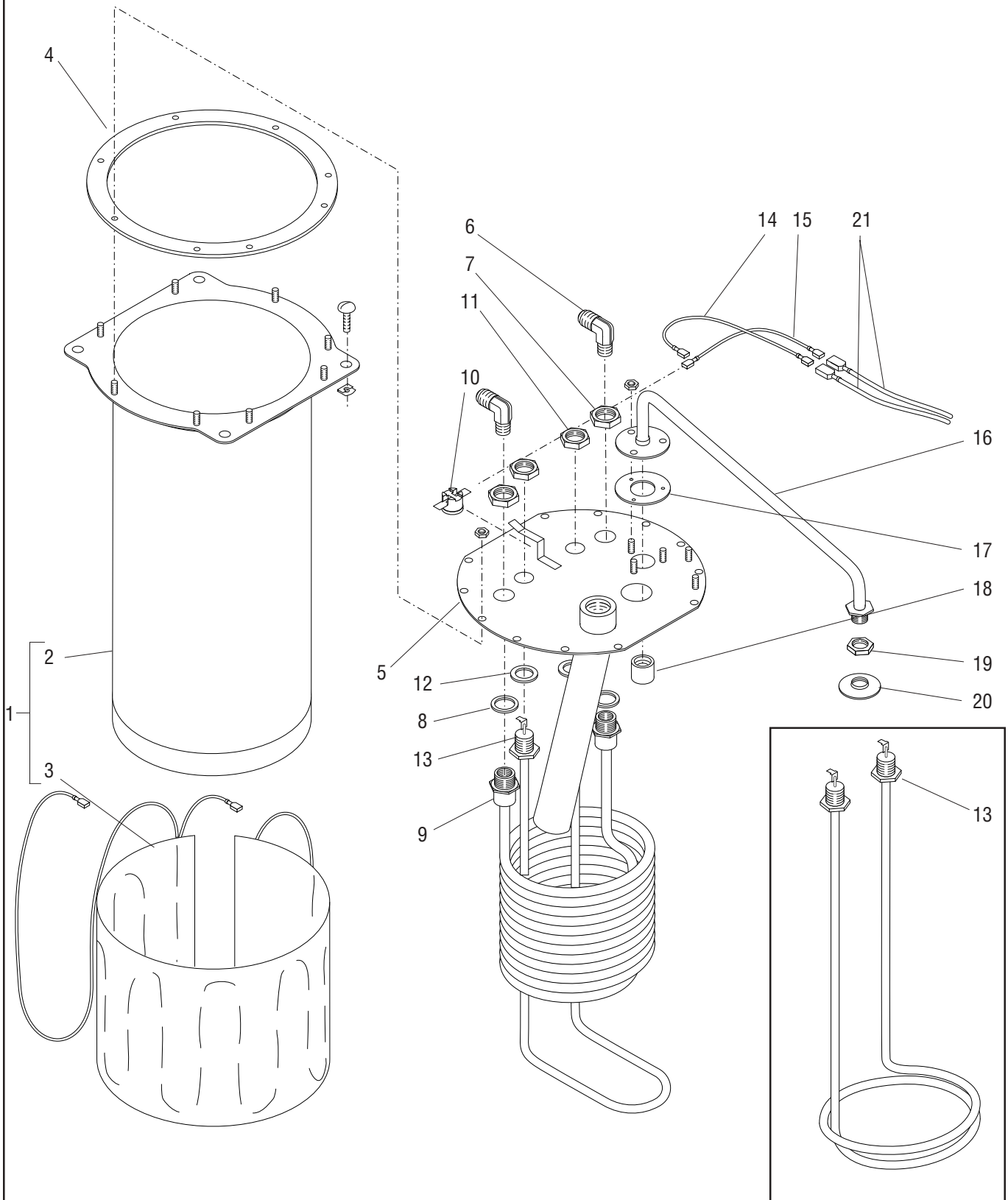

TANK AND COMPONENTS W/FAUCET

ITEM	PART NO.	QTY.	DESCRIPTION
-	25320.1000	1	Tank Assy, 1320W 120V (Includes items 1 thru 18)
	25320.1001	1	Tank Assy, 1800W 120V (Includes items 1 thru 18)
	25320.1002	1	Tank Assy, 3500W 120/240V (Includes items 1 thru 18)
	01315.0000	2	Screw, Truss Head #8-32 x .375"
	00912.0000	2	Fastener, J-Type #8-32
1	04119.0000	1	Tank W/Blanket Warmer, 120V (Includes items 2 & 3)
2	04118.0000	1	Tank
3	04260.0000	1	Blanket Warmer, 50W 120V
4	04221.0000	1	Gasket, Tank Lid
5	25158.0003	1	Tank Lid Weldment
	00908.0000	8	Nut, Hex #8-32
6	00400.0001	2	Elbow, Male .250" Flare x .125" MPT
7	12687.0000	2	Nut, Hex Brass .562"-24 (Water Coil)
8	12688.0000	2	Gasket, Water Coil
9	12689.1000	1	Coil Assy, Hot Water (Includes item 8)
10	29329.1000	1	Thermostat, Limit
11	00942.0000	2	Nut, Hex .50"-20 (Tank Heater)
12	00943.0000	2	Gasket, Tank Heater
13	04236.1000	1	Tank Heater, 1320W 120V
	04636.1000	1	Tank Heater, 1800W 120V
	04637.1000	1	Tank Heater, 3500W 240V
			} Includes item 12
14	20211.0100	1	Thermal Safety Fuse (Thermostat to Heater)
15	23768.0000	1	Lead, Electrical BLU (Thermostat to Limit)
16	11431.0002	1	Sprayhead Tube Kit (Includes 3 mounting nuts below & items 17 & 18)
	00908.0000	3	Nut, Hex #8-32
17	05515.0000	1	Gasket, Sprayhead tube
18	05518.0000	1	Hub, Syphon
19	01075.0000	1	Nut, Hex .438"-20
20	01082.0007	1	Sprayhead, 1-Hole (Brewers With Pouch-Pack Funnel)
21	-----	-	Thermostat Leads (See Electrical and Operating Controls)

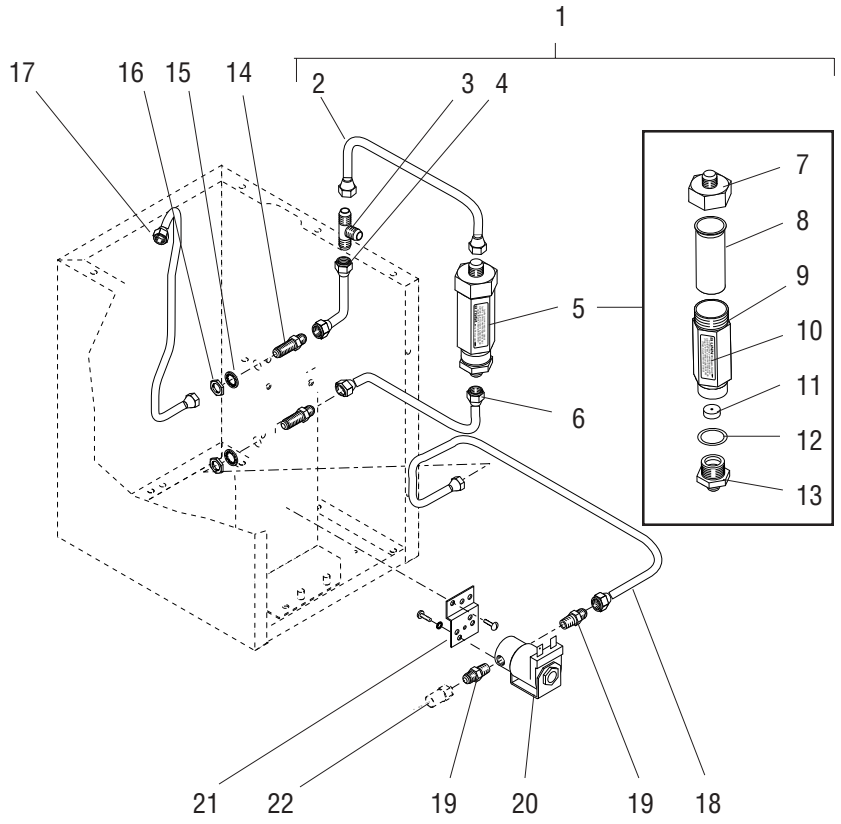

BREWERS WITH FAUCET

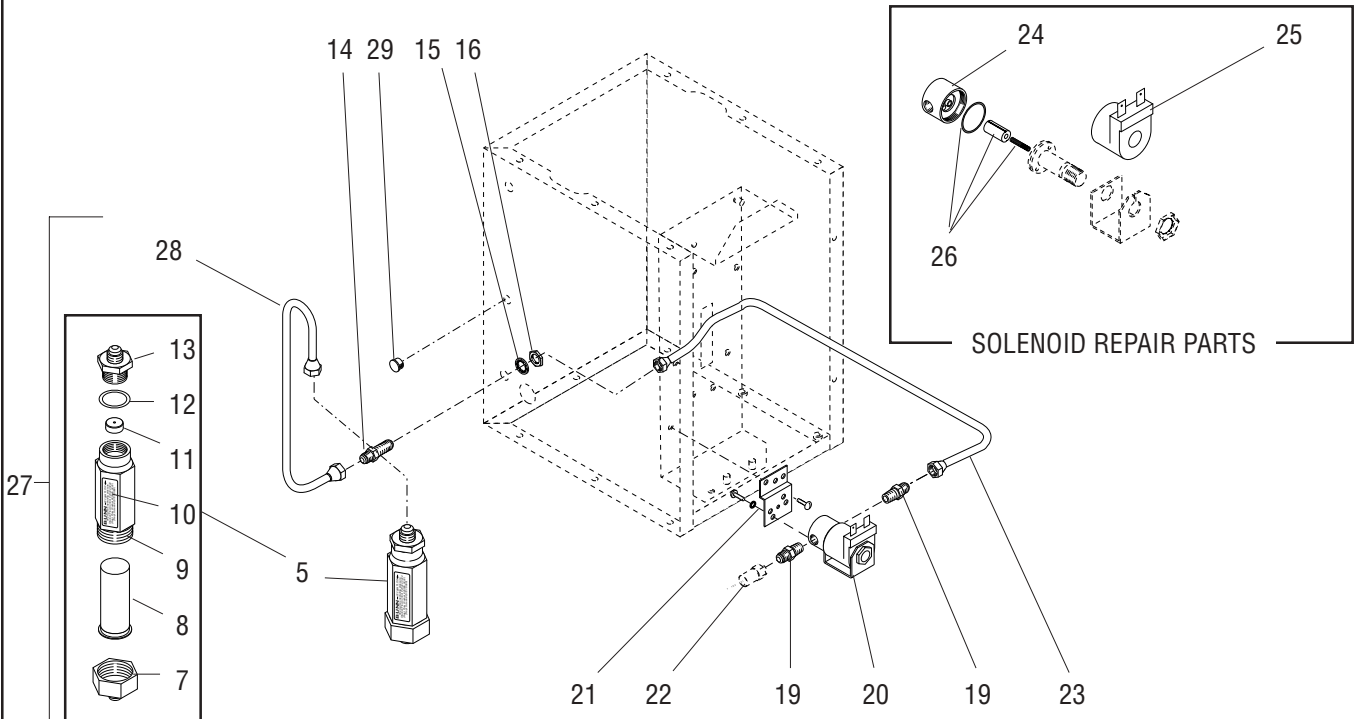

BREWERS WITHOUT FAUCET

STRAINER - FLOW CONTROL, SOLENOID AND LINES

ITEM	PART NO.	QTY.	DESCRIPTION
1	26440.0222	1	Strainer/Flow Control Assembly (.222 GPM) (Includes items 2 thru 6)
2	26216.0000	1	Tube Assembly, Flow Control to Tee
3	20577.0001	1	Tee, .250" Flare
4	21812.0010	1	Tube Assembly, Tee to Bulkhead
5	22300.0222	1	Strainer/Flow Control Assembly (.222 GPM)(Includes items 7 thru 13)
6	26217.0001	1	Tube Assembly, Flow Control to Bulkhead
7	22249.0000	1	Fitting, Flow Control Inlet
8	23721.0000	1	Screen
9	-----	1	Body (Not Available. Order Item 5)
10	22307.0222	1	Decal, (.222 GPM)
11	20526.1222	1	Flow Washer/Gasket Set (.222 GPM)(Includes item 12)
12	01155.0000	1	Gasket, Flow Control
13	01154.0000	1	Fitting, Flow Control Outlet
14	00459.0000	2	Fitting, Bulkhead .250" Flare
15	01532.0000	2	Lockwasher, Internal Tooth .438"
16	00463.0000	2	Nut, Hex .438"-20
17	26322.0000	1	Tube Assembly, Bulkhead to Coil
18	26320.0000	1	Tube Assembly, Bulkhead to Solenoid
19	00402.0001	2	Connector, Male .250" Flare x .125"MPT
20	01085.0000	1	Solenoid Valve, 120V
	01327.0000	2	Screw, Pan Head #10-32 x .375"
	01502.0000	2	Lockwasher, Split #10
21	07441.0000	1	Bracket, Solenoid Mounting
	02308.0000	2	Screw, Pan Head Serrated #8-32 x .375"
22	-----	1	Tube Assembly, Solenoid to Fill Basin (See FILL BASIN)
23	26319.0000	1	Tube Assembly, Bulkhead to Solenoid
24	01079.0000	1	Solenoid Valve Base
25	01101.0000	1	Solenoid Valve Coil, 120V
26	01111.0000	1	Solenoid Valve Repair Kit (Includes Plunger, Seal and Spring)
27	24356.0222	1	Strainer/Flow Control Assembly (.222 GPM) (Includes items 5 & 28)
28	24354.0000	1	Tube Assembly, Flow Control to Bulkhead
29	00670.0000	1	Plug, Hole .437" I.D. (Brewers without Faucet)

One less used on Brewers without Faucet

Solenoid Repair Parts

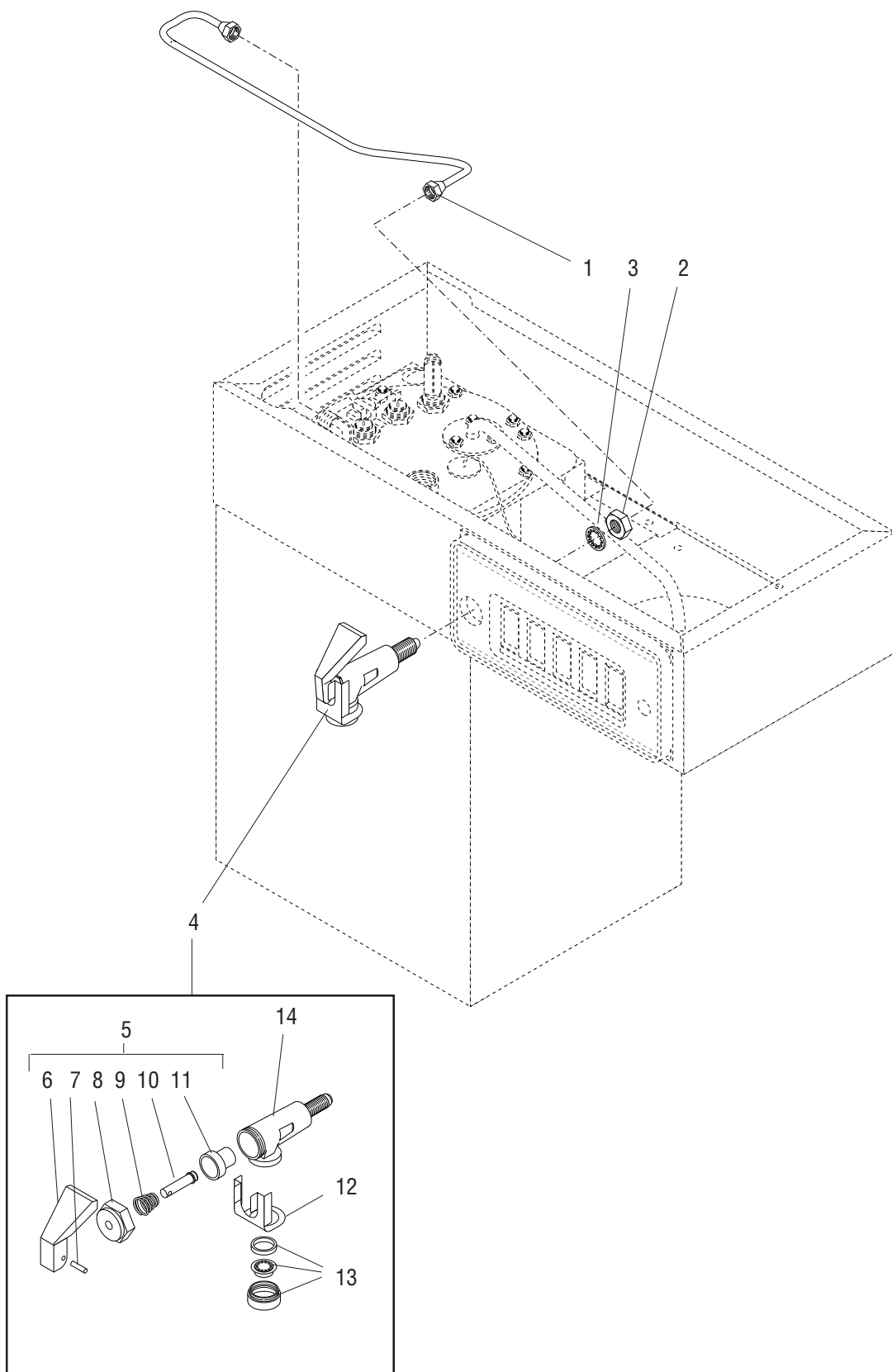

FAUCET AND TUBING

ITEM	PART NO.	QTY.	DESCRIPTION
1	26456.0000	1	Tube Assembly, Coil to Faucet
2	13059.0000	1	Faucet Jam Nut
3	01532.0000	1	Lockwasher, Internal Tooth .438" I.D.
4	12915.0000	1	Faucet, Hot Water (Includes items 5 thru 14)
5	13061.0000	1	Faucet Handle/Stem Assembly (Includes items 6 thru 11)
6	13053.0000	1	Faucet Handle Kit (Includes item 7)
7	02858.0000	1	Pin, Spring .125" Dia x .50"
8	13060.0000	1	Faucet Bonnet Nut
9	13055.0000	1	Faucet Spring
10	13054.0000	1	Faucet Stem
11	13056.0000	1	Faucet Seat Cup
12	13057.0000	1	Faucet Safety Clip
13	13058.0000	1	Faucet Aerator Kit
14	-----	1	Body, Faucet (Not available. Order item 4)

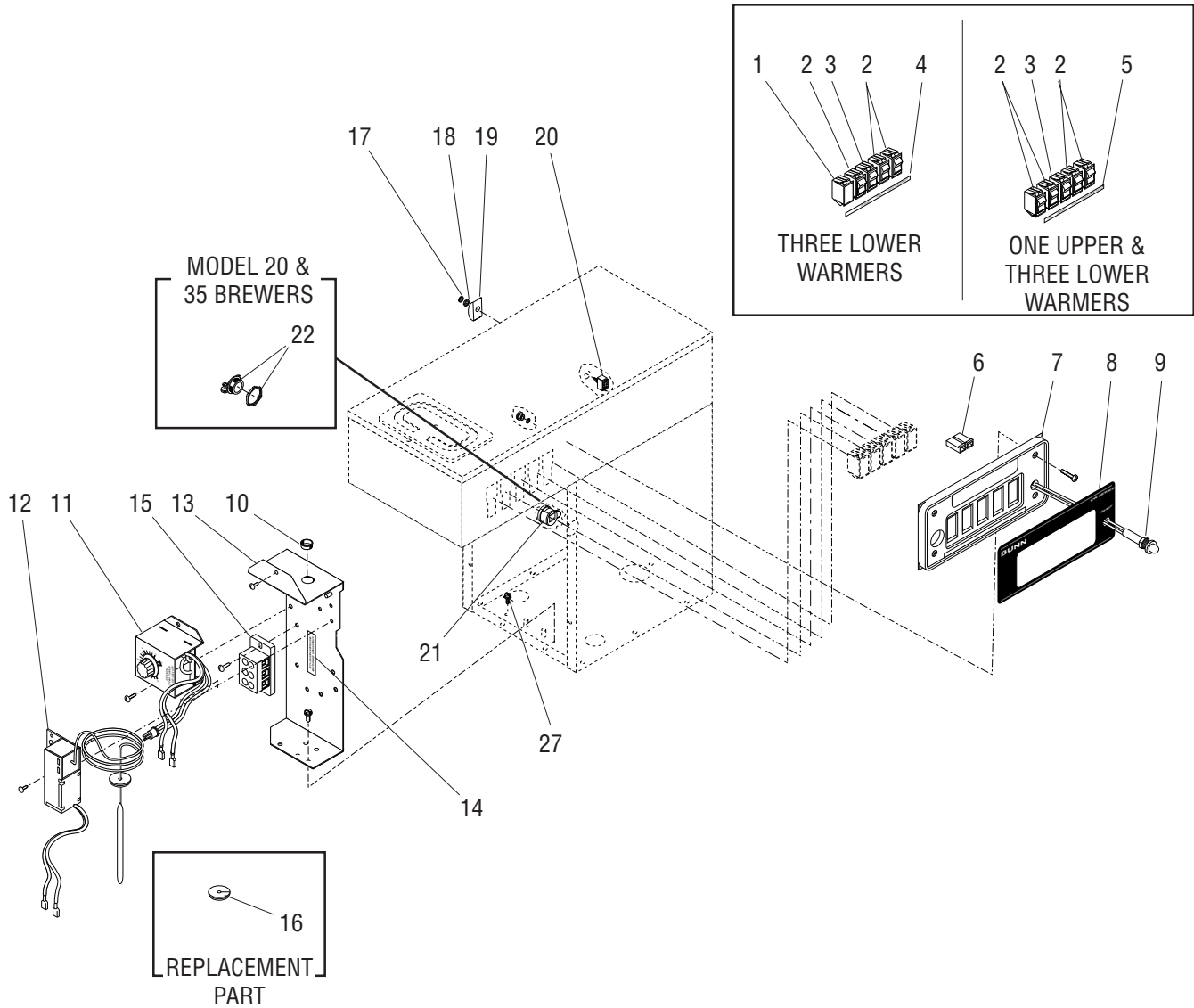

ELECTRICAL AND OPERATING CONTROLS W/OUT FAUCET

ITEM	PART NO.	QTY.	DESCRIPTION
1	12921.0000	1	Switch Blank, BLK
2	12920.0000	4	Switch ON/OFF 120V (One less used on brewers w/out top warmer)
3	01063.0000	1	Switch, Momentary Start
4	22295.0013	1	Label, Switch ON/OFF (Three lower warmer brewer)
5	22295.0014	1	Label, Switch ON/OFF (Four warmer brewer)
6	04243.0000	2	Terminal Housing, Receptacle
7	13352.0008	1	Control Panel
	02301.0000	4	Screw, Phillip Pan Head #6-32 x .625"
	01510.0000	4	Lockwasher, External Tooth #6
	02371.0000	4	Thumb Nut, Knurled #6-32
8	22289.0001	1	Decal, Control Panel
9	12984.0002	1	Light Assembly, 120V Green
	12984.0004	1	Light Assembly, 240V Green
			} Includes Item 6
10	01663.0000	1	Bushing, Snap .875" Dia
11	02235.1000	1	Timer, 5 Min. 120V
	02308.0000	1	Screw, Pan Head-Serrated #8-32 x .375"
12	04227.1001	1	Thermostat Kit
	02308.0000	1	Screw, Pan Head #8-32 x .375"
13	12698.0000	1	Bracket Assembly, Component Mounting
	01347.0000	1	Screw, Truss Head #6-32 x .375" (Early Models)
	02308.0000	1	Screw, Pan Head #8-32 x .375" (Late Models)
	02332.0001	1	Screw, Hex-Crimptite #6 x .250"
14	00870.0000	1	Decal, Use Copper Wire Only
15	07038.0000	1	Terminal Block, 3 Pole-Red/White/Black
	01317.0000	2	Screw, Truss Head #8-32 x .50"
16	07073.0000	1	Grommet, Thermostat
17	23697.0000	1	Facenut, Plastic
18	23696.0000	1	Nut, Hex
19	25102.0000	1	Bracket, Switch Indicator/Guard
20	23522.0000	1	Switch, ON/OFF Toggle (Includes item 18)
21	01686.0000	1	Bushing, Strain Relief (Model 115 Brewers)
22	01685.0000	1	Connector, Cable .50 MPT (Model 20 & 35 Brewers)
23	01719.0000	1	Power Cord Assembly (Model 15 Brewers Only)
24	12985.0000	1	Wiring Harness, Ready Light
25	25328.0000	1	Wiring Harness, Main 120V
	25329.0000	1	Wiring Harness, Main 120V/240V
26	12919.0000	-	Cap, Terminal (Use as required)
27	02337.0001	1	Screw, Hex Head #10 x .375" (Cord Ground)

} Not Illustrated

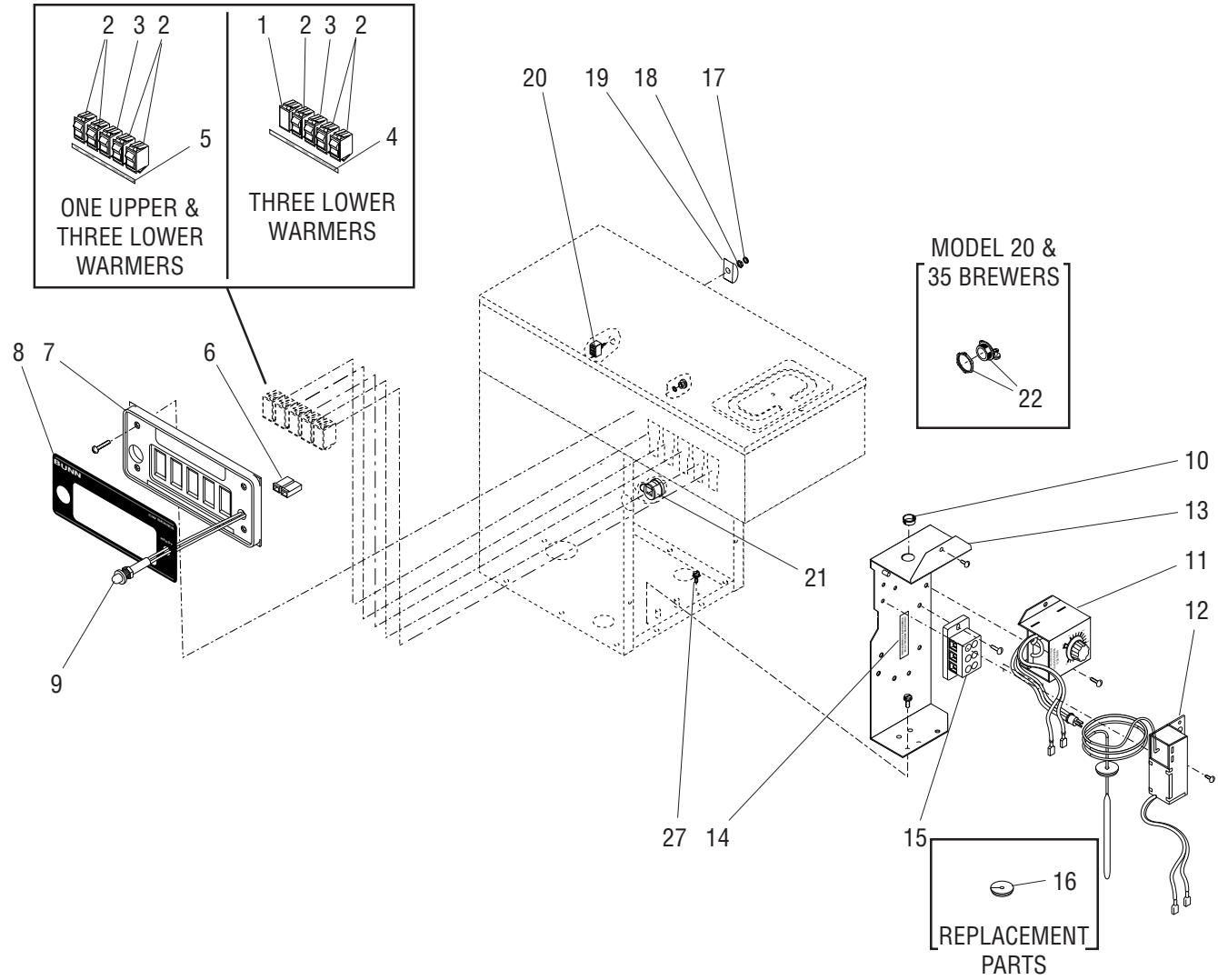

ELECTRICAL AND OPERATING CONTROLS W/FAUCET

ITEM	PART NO.	QTY.	DESCRIPTION
1	12921.0000	1	Switch Blank, BLK
2	12920.0000	4	Switch ON/OFF 120V (One less used on brewers w/out top warmer)
3	01063.0000	1	Switch, Momentary Start
4	22295.0013	1	Label, Switch ON/OFF (Three lower warmer brewer)
5	22295.0014	1	Label, Switch ON/OFF (Four warmer brewer)
6	04243.0000	2	Terminal Housing, Receptacle
7	13352.0008	1	Control Panel
	02301.0000	4	Screw, Phillip Pan Head #6-32 x .625"
	01510.0000	4	Lockwasher, External Tooth #6
	02371.0000	4	Thumb Nut, Knurled #6-32
8	22289.0003	1	Decal, Control Panel
9	12984.0002	1	Light Assembly, 120V Green
	12984.0004	1	Light Assembly, 240V Green
			} Includes item 6
10	01663.0000	1	Bushing, Snap .875" Dia
11	02235.1000	1	Timer, 5 Min. 120V
	02308.0000	1	Screw, Pan Head-Serrated #8-32 x .375"
12	04227.1001	1	Thermostat Kit
	02308.0000	1	Screw, Pan Head #8-32 x .375"
13	12698.0000	1	Bracket Assembly, Component Mounting
	01347.0000	1	Screw, Truss Head #6-32 x .375" (Early Models)
	02308.0000	1	Screw, Pan Head #8-32 x .375" (Late Models)
	02332.0001	1	Screw, Hex-Crimptite #6 x .250"
14	00870.0000	1	Decal, Use Copper Wire Only
15	07038.0000	1	Terminal Block, 3 Pole-Red/White/Black
	01317.0000	2	Screw, Truss Head #8-32 x .50"
16	07073.0000	1	Grommet, Thermostat
17	23697.0000	1	Facenut, Plastic
18	23696.0000	1	Nut, Hex
19	25102.0000	1	Bracket, Switch Indicator/Guard
20	23522.0000	1	Switch, ON/OFF Toggle (Includes item 18)
21	01686.0000	1	Bushing, Strain Relief (Model 15 Brewers)
22	01685.0000	1	Connector, Cable .50 MPT (Model 20 & 35 Brewers)
23	01719.0000	1	Power Cord Assembly (Model 15 Brewers Only)
24	12985.0000	1	Wiring Harness, Ready Light
25	25328.0000	1	Wiring Harness, Main 120V
	25329.0000	1	Wiring Harness, Main 120V/240V
26	12919.0000	-	Cap, Terminal (Use as required)
27	02337.0001	1	Screw, Hex Head #10 x .375" (Cord Ground)

} Not Illustrated

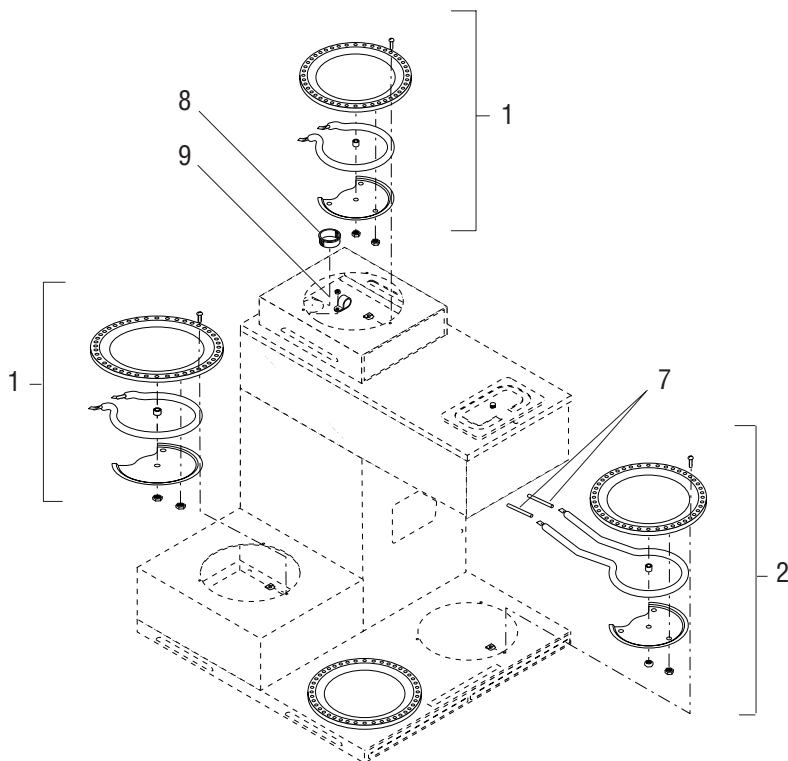
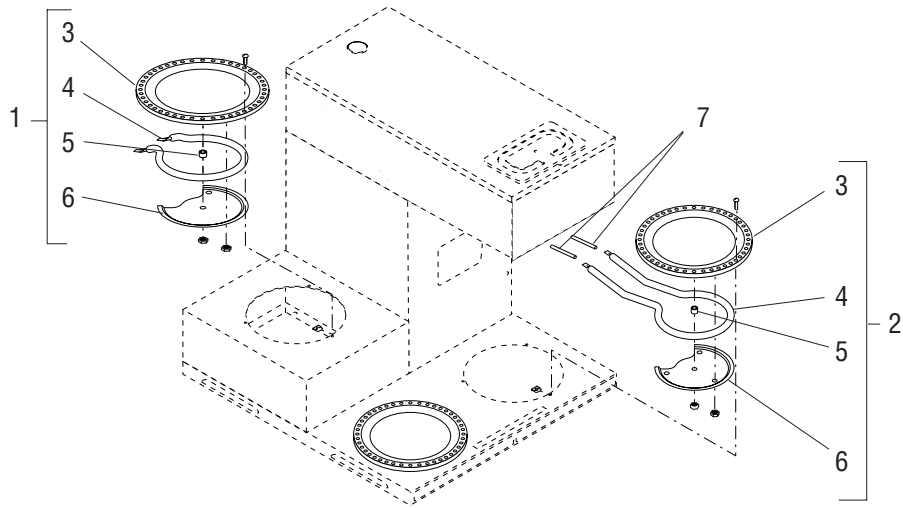

WARMER ASSEMBLIES

ITEM	PART NO.	QTY.	DESCRIPTION
1	03652.0000	1	Warmer Assembly 100W 120V, Top and Side Warmers (Includes items 3 thru 6)
	01303.0000	3	Screw, Pan Head #4-40 x .50"
	00916.0000	3	Fastener, J-Type #4-40
2	11440.0005	1	Warmer Assembly 100W 120V, Base Warmers (Includes items 3 thru 6)
	01303.0000	3	Screw, Pan Head #4-40 x .50"
	00916.0000	3	Fastener, J-Type #4-40
3	03656.0000	1	Warmer Dish, Blk 45 Hole
4	01227.0000	1	Warmer Element 100W 120V Top and Side Warmers
	11442.0000	1	Warmer Element 100W 120V Base Warmers
5	13042.0001	1	Spacer, .174" I.D. x .188
6	05212.0000	1	Plate, Element Retaining
	00970.0000	2	Nut, Keps #8-32
7	-----	2	Tube, Silicone .250" Dia x 1.88" LG. (Order Item 11)
8	-----	1	Bushing, Snap 1.188" Dia. (See Hood And Top Covers)
9	28382.0000	1	Clamp, Routing
10	25348.0000	1	Wiring Harness, Top Warmer 120V
	24204.0001	1	Wiring Harness, Three Warmer Brewers 120V
	25326.0000	1	Wiring Harness, Four Warmer Brewers 120V
11	04828.1001	-	Tube, Silicone .250" Dia. x 24" LG (Use as required)

Not
Illustrated

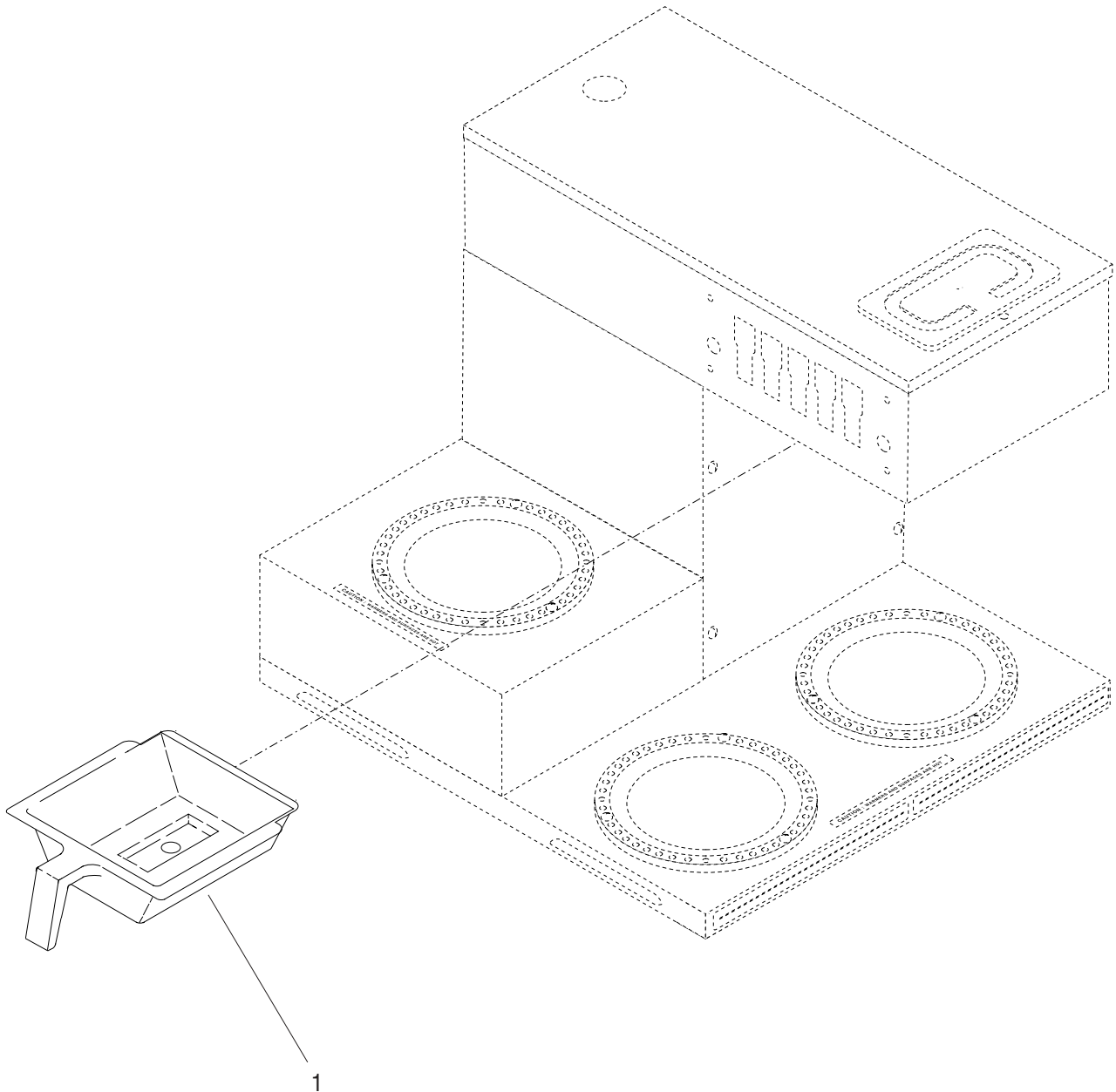

FUNNEL

ITEM	PART NO.	QTY.	DESCRIPTION
1	04274.0002	1	Funnel, Pouch-Pack Black (Large)(7.125")

NUMERICAL INDEX

PART NO.	PAGE NO.	PART NO.	PAGE NO.	PART NO.	PAGE NO.	PART NO.	PAGE NO.
00400.0001	13	02765.0000	5,7	13060.0000	17	26513.0000	5
00402.0001	15	02858.0000	17	13061.0000	17	26513.0001	7
00459.0000	15	02999.0000	5,7	13255.0005	5	28382.0000	23
00463.0000	15	03359.0001	5,7	13350.0012	7	29329.1000	11,13
00656.0000	5,7	03652.0000	23	13350.0013	5		
00658.0000	5,7	03656.0000	23	13352.0008	19,21		
00670.0000	5,15	03993.0000	5,7	13354.0000	5,7		
00831.0000	5,7	04118.0000	11,13	20211.0100	13		
00870.0000	19,21	04119.0000	11,13	20526.1222	15		
00908.0000	11,13	04221.0000	11,13	20577.0001	15		
00912.0000	5,7,11,13	04227.1001	19,21	21812.0010	15		
00916.0000	5,7,23	04236.1000	11,13	22249.0000	15		
00942.0000	11,13	04243.0000	19,21	22289.0001	19		
00943.0000	11,13	04260.0000	11,13	22289.0003	21		
00970.0000	23	04270.0002	9	22295.0013	19,21		
00988.0000	5,7	04274.0002	25	22295.0014	19,21		
01063.0000	19,21	04636.1000	11,13	22300.0222	15		
01075.0000	11,13	04637.1000	11,13	22306.0000	5,7		
01079.0000	15	04828.1001	23	22307.0222	15		
01082.0007	11,13	05212.0000	23	23522.0000	19,21		
01085.0000	15	05515.0000	11,13	23696.0000	19,21		
01101.0000	15	05518.0000	11,13	23697.0000	19,21		
01111.0000	15	07038.0000	19,21	23721.0000	15		
01154.0000	15	07073.0000	19,21	23768.0000	11,13		
01155.0000	15	07441.0000	15	23769.0000	11		
01201.0000	9	10836.0000	5,7	24204.0001	23		
01212.0000	9	11424.0000	9	24354.0000	15		
01227.0000	23	11431.0002	11,13	24356.0222	15		
01303.0000	5,7,23	11440.0005	23	25102.0000	19,21		
01315.0000	11,13	11442.0000	23	25144.0004	5,7		
01317.0000	19,21	12364.0000	5,7	25158.0002	11		
01319.0000	5,7	12667.0001	5,7	25158.0003	13		
01327.0000	15	12687.0000	13	25310.0001	5,7		
01347.0000	19,21	12688.0000	13	25319.1000	11		
01382.0000	5,7	12689.1000	13	25319.1001	11		
01502.0000	15	12698.0000	19,21	25319.1002	11		
01510.0000	19,21	12914.0002	9	25320.1000	13		
01532.0000	15,17	12915.0000	17	25320.1001	13		
01592.0000	5,7	12919.0000	19,21	25320.1002	13		
01592.0001	5,7	12920.0000	19,21	25326.0000	23		
01593.0000	5,7	12921.0000	19,21	25328.0000	19,21		
01663.0000	19,21	12928.0000	9	25329.0000	19,21		
01685.0000	19,21	12984.0002	19,21	25348.0000	23		
01686.0000	19,21	12984.0004	19,21	25633.0003	5,7		
01719.0000	19,21	12985.0000	19,21	25657.0000	5,7		
02235.1000	19,21	13042.0001	23	25658.0001	5,7		
02301.0000	19,21	13053.0000	17	26216.0000	15		
02308.0000	5,7,15,19,21	13054.0000	17	26217.0001	15		
02332.0001	19,21	13055.0000	17	26319.0000	15		
02332.0002	5,7	13056.0000	17	26320.0000	15		
02337.0001	19,21	13057.0000	17	26322.0000	15		
02371.0000	19,21	13058.0000	17	26440.0222	15		
02722.0000	5,7	13059.0000	17	26456.0000	17		