

Features

Gourmet Ice® System

- Three large 3½ gallon hoppers for high volume serving capacity.
- Engineered for long reliable life with heavy-duty motors, compressor, and seals.
- Advanced electronic controls are designed for easy operation and provide perfect ice consistency.
- Full one year parts and labor warranty. See the product manual for additional details.
- Includes timer for automatic night setting.
- 2-year warranty on compressor.
- Sanitation listed by ETL to NSF Standard 18 (includes dairy & alcohol) and safety listed by ETL to UL Standard (UL 471) and CSA Standard (C22.2 No. 120).



Model CDS-3

ITEM#

PROJECT

DATE

Model

CDS-3

For available variations to some BUNN products, please contact your BUNN sales representative.

BUNN recommends the use of our Easy Clear® Water Quality Systems to assure perfect taste.

Easy Clear® EQ-11-TL
Product No. : 30344.1001
Dimensions:
15⁷/₈" H x 3⁵/₈" W x 4¹⁷/₃₂" D

Easy Clear® ED-11-TL
Product No. : 30244.1001
Dimensions:
14³/₁₆" H x 5¹/₁₆" W x 5¹/₁₆" D



Autofill System

- Easy to install.
- Completely self-contained and electronically controlled.
- Includes three independent pumps and refill probes.
- Mix range on post-mix model - 1:1 up to 8:1.
- Separate product and water lines to improve sanitation.

AFPO-3 SL Autofill System (Post-Mix)

Product No. : 28400.0005 (Specifications on back)



BUNN®

Corporate Offices
1400 Stevenson Drive
Springfield, Illinois 62703
Phone
800-637-8606
217-529-6601
Fax
217-529-6644
Technical Services
800-286-6070
Internet
<http://www.bunnomatic.com>

Western Regional Office
16431 Carmenita Road,
Cerritos, California 90701
Phone
562-926-0764
Fax
562-926-0858

Canadian Office
280 Industrial Parkway South
Aurora, Ontario, L4G 3T9
Phone
905-841-2866
Fax
905-841-2775

Patents
Apply



Dimensions & Specifications

Model	Product #	Volts	Amps	Capacity	Cu. Ft.	Shipping Weight	Cord Attached
CDS-3 (White/Stainless)	29300.0002	120	20	3 hoppers @ 3½ gal. each	31.5	209 lbs. (102.3 kg)	Yes
CDS-3 (Black/Stainless)*	29300.0015	120	20	3 hoppers @ 3½ gal. each	31.5	209 lbs. (102.3 kg)	Yes
CDS-3 (White/Stainless)†	29300.0000	120	20	3 hoppers @ 3½ gal. each	31.5	209 lbs. (102.3 kg)	Yes
CDS-3 (White/Stainless)**	29300.0003	120	20	3 hoppers @ 3½ gal. each	31.5	209 lbs. (102.3 kg)	Yes
CDS-3 (All Black)*	29300.0016	120	20	3 hoppers @ 3½ gal. each	31.5	209 lbs. (102.3 kg)	Yes
AFPO-3 SL (post-mix)	28400.0005	120	15	108 oz./minute (max.)	2.6	44 lbs. (20.0 kg)	Yes
Autofill Hopper Only	28079.1001	n/a	n/a	3½ gallons	2.6	8 lbs. (3.6 kg)	n/a

* Models are non-stock items. ** Model has Autofill-Ready hoppers. † Model has a black drip tray.

CDS-3 (All Models)

Electrical: Models require 2-wires plus ground service rated 120V, single phase, 60 Hz.

AFPO-3 SL

Electrical: Model requires 2-wires plus ground service rated 120V, single phase, 60 Hz.

Plumbing: 20-90 psi (138-621 kPa). Machine supplied with ¼" male flare fitting.

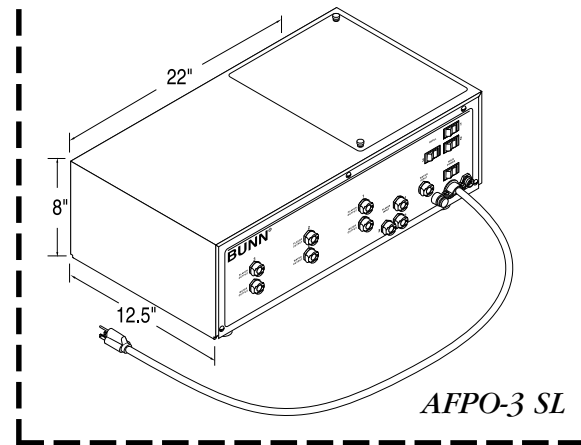

AFPO-3 SL

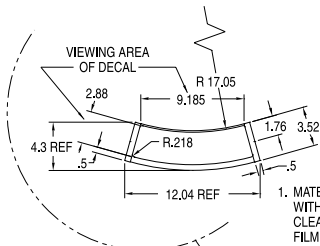
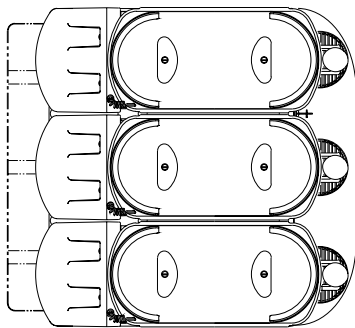

1. MATERIAL: .030 POLYCARBONATE WITH HARD COAT - GE HP92 CLEAR LEXAN PROTECTIVE FILM OVER HARD COAT.
2. ARTWORK AND DIECUT TO BE REGISTERED AS SHOWN.
3. SECOND SURFACE PRINTED.

