

Thermal Server Coffee Brewer

Features

Thermal Server Coffee Brewer

- Brew capacity varies by model. See back for details.
- Brewer measures only 9" (22.9 cm) wide.
- Convenient thermal servers keep coffee hot and fresh for hours.
- Thermal servers are easily transported to remote meeting rooms, breakfast bars, etc.
- Pourover feature included on all models.
- Internal components are constructed from stainless steel.
- Hot water faucet on all models.
- SplashGard® funnel deflects hot liquids away from the hand.
- Holds up to 4" (10.2 cm) cup.



**Model CWTF TS
with Thermal Server**
(Thermal Server sold separately)
Dimensions: 27.6" H x 9" W x 18.5" D
(70.1cm H x 22.9cm W x 47cm D)

For current specification sheets and other information, go to www.bunn.com.

International models may vary in appearance.

Related Products

Easy Clear® EQ-17-TL
Product No. : 30200.1000



Easy Clear® ED-17-TL
Product No. : 30201.1001

Paper Filter Pack
Product No. : 20115.0000
Packed per case: 1,000



Thermal Server Booster*
Product No. : 18010.6000



Thermal Server-Black
Product No. : 23300.0007



**To be used in conjunction with Thermal Server without base. Product No. : 23300.0010 & 23300.0006*

Dimensions & Specifications

Model	Product #	Volts	Amps	Tank Heater Watts	Total Watts	Brewing Capacity	Shipping Weight	Cord Attached	Agency
CWTFA-TS	23000.0023	230	9	2000	2100	5.7 gal./hr. (21.6 L/hr.)	32 lbs. (14.6 kg)	No	☐☐
CWTFA35-TS	23000.0019	230	14.2	3200	3280	7.5 gal./hr. (28.4 L/hr.)	32 lbs. (14.6 kg)	No	☐☐
CWTFA35-TS	23000.0031	220	13.6	2941	3000	7.5 gal./hr. (28.4 L/hr.)	33.9 lbs. (15.4 kg)	No	☐☐
CWTFB-TS	23000.0033	100	12.9	1250	1290	3.6 gal./hr. (13.6 L/hr.)	33.9 lbs. (15.4 kg)	Yes	
CWTFB-TS	23000.0034	200	18	3500	3600	7.5 gal./hr. (28.4 L/hr.)	33.9 lbs. (15.4 kg)	No	

Brewing capacity: base on incoming water temp of 60°F/15°C (140°F/60°C rise) per 1/2 gallon.

Electrical: 230V model requires 2-wires plus ground service rated 220-240V, single phase, 50/60 Hz.

220V model requires 2-wires plus ground service rated 220-240V, single phase, 60 Hz.

100/200V model requires 2-wires plus ground service rated 220-240V, single phase, 60 Hz.

Plumbing: 20-90 psi (69-621 kPa). Supplied with 1/4" male flare fitting.

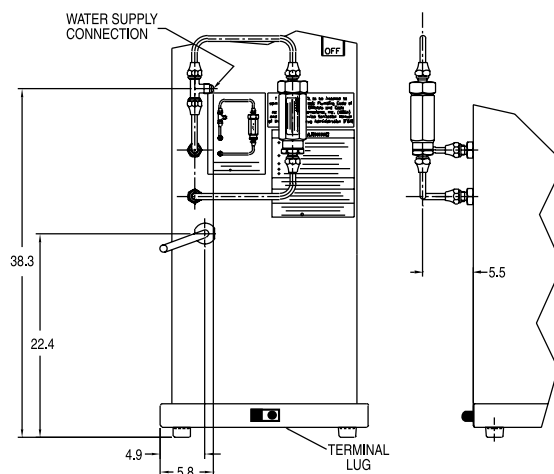
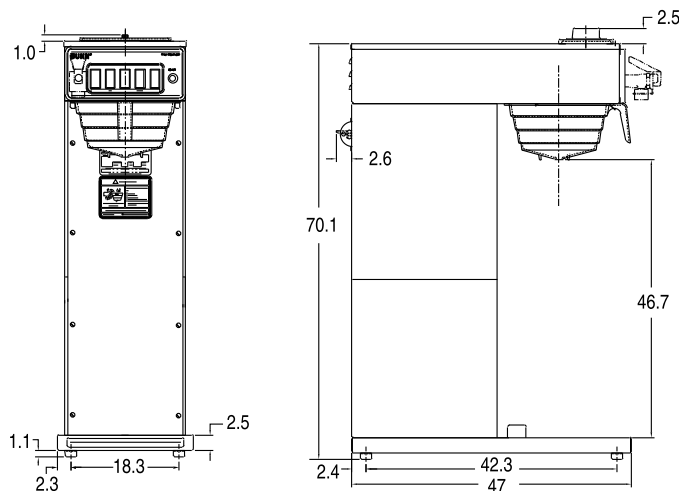

Bunn-O-Matic® Corporation - 1400 Stevenson Drive Springfield, Illinois 62703 • USA • +1-217-529-6601 • Fax +1-217-529-2827 • www.bunn.com

BUNN® practices continuous product research and improvement. We reserve the right to change specifications and product design without notice. Such revisions do not entitle the buyer to corresponding changes, improvements, additions or replacements for previously purchased equipment.

All dimensions shown in centimeters. Bunn-O-Matic Corporation owns all copyrights relating to materials in this publication. Please contact BUNN to request permission to reproduce any portion of this publication.