



# PH188, PH1820 & PH1840 HEAVY-DUTY HEATED TRANSPORT CARTS (top mounted heating system) Universal Slides

CARTER-HOFFMANN

**11**

FOOD SERVICE EQUIPMENT  
HEATED TRANSPORT CARTS

# SPECIFICATIONS

Printed in U.S.A. F30 0909  
Carter-Hoffmann is a trademark  
of Carter-Hoffmann LLC

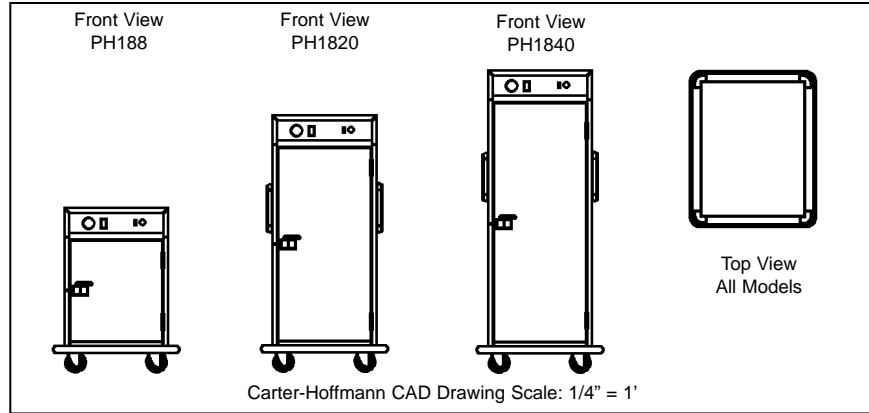

Model Number	Tray/Pan Capacity*		Slide Pairs Standard	Inside Working Height		Overall Dimensions						Caster Diameter		Shipping Weight	
	18"x26"	12"x20"		in	mm	Height		Depth		Width		in	mm	lbs	kgs
						in	mm	in	mm	in	mm				
<input type="checkbox"/> PH188	6	12	6	23 <sup>1</sup> / <sub>4</sub>	591	40 <sup>1</sup> / <sub>4</sub>	1022	38	965	31 <sup>1</sup> / <sub>2</sub>	800	5	127	335	152
<input type="checkbox"/> PH1820	12	24	12	45 <sup>3</sup> / <sub>4</sub>	1162	62 <sup>3</sup> / <sub>4</sub>	1594	38	965	31 <sup>1</sup> / <sub>2</sub>	800	6	152	440	200
<input type="checkbox"/> PH1840	15	30	15	57 <sup>1</sup> / <sub>2</sub>	1461	75 <sup>7</sup> / <sub>8</sub>	1927	38	965	31 <sup>1</sup> / <sub>2</sub>	800	6	152	500	227

\* Capacity shown at 3 1/2" spacing. Tray slides adjustable on 1 3/4" increments. Universal models will accommodate Gastronorm 2/1 pans (1 per slide), 1/1 pans (2 per slide) And 12"x20" glass racks.

**CONSTRUCTION...** Completely welded cabinet construction and top corners, with outer cabinet formed to base and welded. All seams turned in to eliminate raw edges. Tamper-resistant fasteners.

**CABINET MATERIAL...** All stainless steel construction; 20 gauge polished exterior and 24 gauge interior.

**BASE FRAME...** 12 gauge stainless steel full depth bolsters with 1"x1" 14 gauge stainless steel perimeter tube supports welded to bolsters.

**CASTERS...** 5" (PH188) and 6" (PH1820 & PH1840) diameter, all swivel, polyurethane tread. Sealed roller bearing and double ball bearing swivel. Zerk grease fittings. Plated mounted and bolted to base in offset wheel-ahead pattern.

**BUMPER...** Non-marking gray vinyl bumper set in heavy-duty 3/16" thick extruded aluminum frame with reinforced corner cutouts.

**INSULATION...** High density fiberglass, full 1" thick continuous wrap-around type fiberglass insulation.

**DOORS...** Removable, flush mounted design. Double panel stainless steel; 20 gauge polished exterior and 20 gauge interior. Filled with 1" thick high density fiberglass insulation.

**HINGES...** 12 gauge stainless steel butt style hinges with 3/8" diameter stainless steel rod pins, fully welded to cabinet.

**LATCH...** Flush mounted heavy-duty slide latch for positive closing of door.

**HANDLES...** PH1820 & PH1840: two 1" diameter stainless steel tubular handles, vertically mounted and welded to cabinet.

**TRAY RACK ASSEMBLIES...** 16 gauge universal slides, fully adjustable at 1 3/4" spacing, placed into 18 gauge stainless steel baffles. Standard spacing at 3 1/2". Security hold down device for rack assembly.

**THERMOMETER...** Dial type with remote sensing bulb. Set flush with control panel. Protective Lexan cover.

**HEATING SYSTEM...** Top mounted, all stainless steel construction. 1500 watt inconel-sheathed heating element. High impedance protected, internally cooled fan motor. Manual reset high-limit switch to protect all internal components. Features include removable large capacity humidifying pan, on/off toggle switch, power indicating light, thermostat control knob, recessed 12 gauge stainless steel cord wrap, remote thermostat sensing bulb. Heater security hold-downs require tools to remove heater.

**ELECTRICAL CHARACTERISTICS...** Operates on 120 volts, 60 cycle, single phase, 1500watts, 13 amps. Ten foot 3 wire rubber cord with 3 prong grounding plug. NEMA 5-15P.

**PERFORMANCE...** Capable of heating to 200° F (94° C). Preheat to 160° F (71° C) in approximately 25 minutes.

**ACCESSORIES/OPTIONS...**

- Locking door latch
- Menu card holder
- Alternate caster sizes and types
- Alternate electrical configurations

Specifications subject to change through product improvement & innovation.

**CARTER-HOFFMANN**

1551 McCormick Ave., Mundelein, IL 60060  
(847) 362-5500 • (800) 323-9793 • Fax (847) 367-8981  
[www.carter-hoffmann.com](http://www.carter-hoffmann.com)



# FEATURES & BENEFITS

## PH188, PH1820 & PH1840 HEAVY-DUTY HEATED TRANSPORT CARTS

*Since 1947, foodservice equipment that delivers!*

### TOP MOUNTED HEATER...

Blower heating system with side mounted interior heat ducts for fast heat up, recovery and even heat distribution throughout cabinet. Removable with tools for easy maintenance and cleaning.

### COMPLETELY WELDED TURNED-IN SEAM CONSTRUCTION...

Adds rigidity to entire cabinet and eliminates raw edges for easy cleaning and safety.

### HEAVY-DUTY STAINLESS STEEL BASE FRAME...

12 gauge caster bosters with tubular perimeter frame to withstand heavy loads and harsh transport conditions.

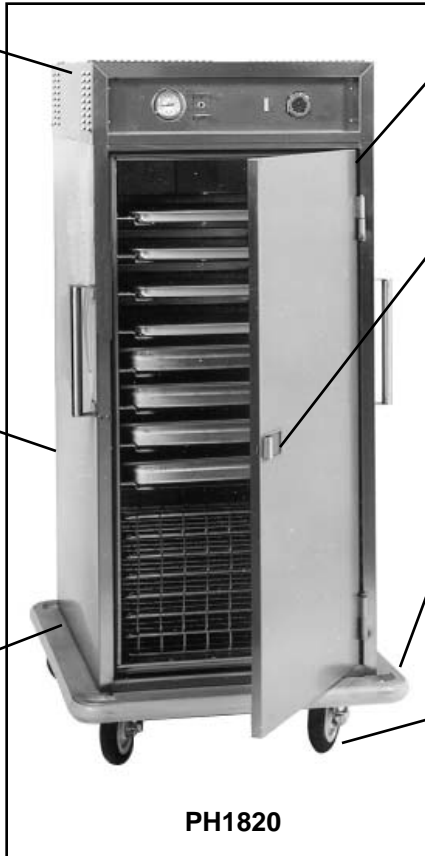

PH1820

**RECESSED DOOR...** Flush mounted design protects door and hinges from damage during transport.

**FLUSH MOUNTED SLIDING DOOR LATCH...** Exclusively designed for transport applications. Door remains closed during transport. Flush design protects latch from damage.

**NON-MARKING BUMPER SET IN HEAVY-DUTY 3/16" THICK EXTRUDED ALUMINUM FRAME...** Protects doorways, walls and cart from damage.

**OFFSET "WHEEL AHEAD" PATTERN...** Only one wheel can pass over uneven surfaces at a time for easy handling and steering.

**POLYURETHANE TREAD  
CASTERS WITH SEALED  
ROLLER BEARING...** Long lasting, easy rolling for maximum load and minimum maintenance.

1551 McCormick Avenue, Mundelein, Illinois 60060  
Tel. (847)362-5500 • (800)323-9793 • Fax (847)367-8981  
[www.carter-hoffmann.com](http://www.carter-hoffmann.com)

