



Countertop Display Refrigerators



*Keeps
Food & Beverages
Chilled*

Standard Features



- **Choice** – Model CTR2.68LD with illuminated header display or model CTR3.75 with extra capacity.
- **Adjustable Thermostat** – Temperature can be adjusted between 34°F and 45°F.
- **Energy Efficient** – Double pane thermal glass door with strong magnetic gasket.
- **Impulse Sales** – Merchandise packaged food & beverages.
- **ETL Sanitation Conforms To NSF 7 Standard.**
- **Durable Black Powder Coated Exterior Finish.**
- **Bright Interior Merchandise Lighting.**
- **Adjustable PVC Coated Wire Shelves.**
- **Secure Built-In Door Lock.**

Specifications subject to change without notice.

Countertop Display Refrigerators



Models & Dimensions

CTR2.68LD Refrigerator with Illuminated Header

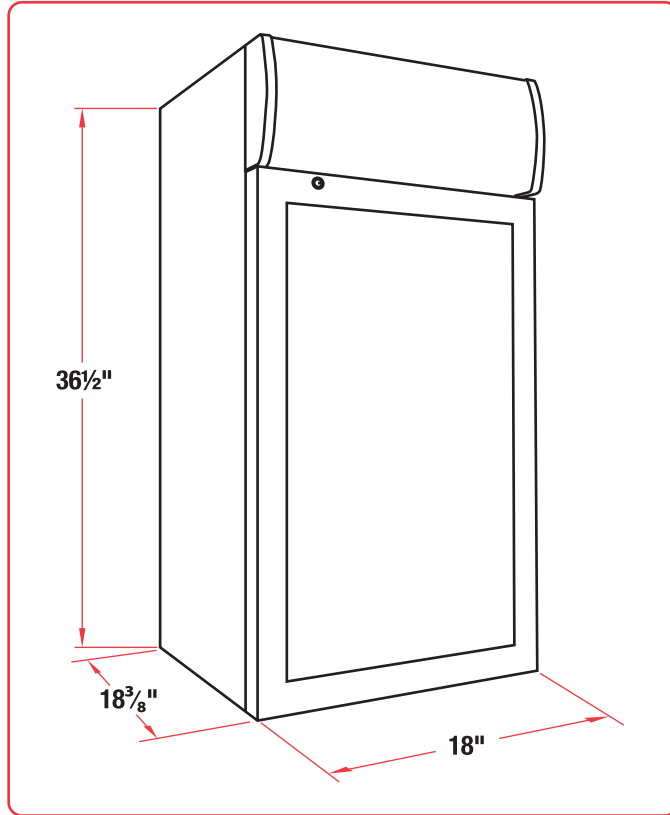

CTR3.75 Five Shelf Refrigerator

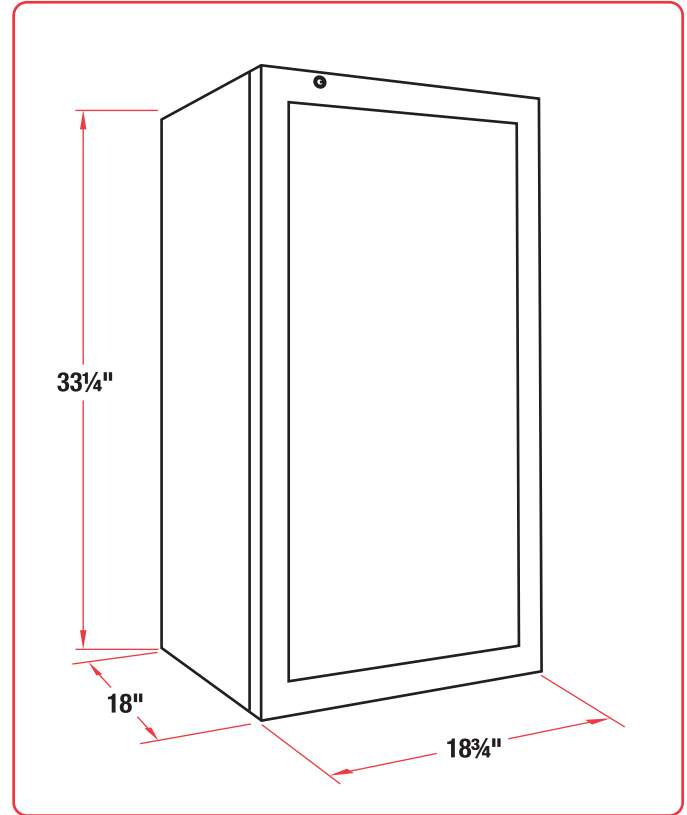

Options

Additional Shelves For CTR2.68LD Part # 08725 Additional Shelves For CTR3.75 Part # 08727

Custom display graphics are available for CTR2.68LD at an additional charge, please contact Cecilware marketing for more information.



Specifications

Model	Cubic Ft.	Shelves	Temp.	HP	Dimensions W x D x H	Electrical	Ship Weight
CTR2.68LD	2.7	4	34°F - 45°F	1/8	18" x 18 3/8" x 36 1/2"	120V, .09KW, 1.8A	90 lbs.
CTR3.75	3.8	5	34°F - 45°F	1/8	18 3/4" x 18" x 33 1/4"	120V, .09KW, 2A	85 lbs.

Electrical: Cord & plug set included, Nema plug 5-15P. Refrigerant: R-134a. Finish: Black.

Specifications subject to change without notice.

WARRANTY
One year on parts and labor.
Five years on compressor.
(U.S.A. Only)



Cecilware Corporation
43-05 20th. Avenue, LIC NY 11105
Tel: 800.935.2211 / 718.932.1414
Fax: 718.932.7860 • www.cecilware.com
Email: customer.service@cecilware.com