



www.cornelius.com

Installation Manual

ICE/BEVERAGE DISPENSER

Model: Enduro-200/250

IMPORTANT:

TO THE INSTALLER.

It is the responsibility of the Installer to ensure that the water supply to the dispensing equipment is provided with protection against backflow by an air gap as defined in ANSI/ASME A112.1.2-1979; or an approved vacuum breaker or other such method as proved effective by test.

Water pipe connections and fixtures directly connected to a potable water supply shall be sized, installed, and maintained according to Federal, State, and Local Codes.

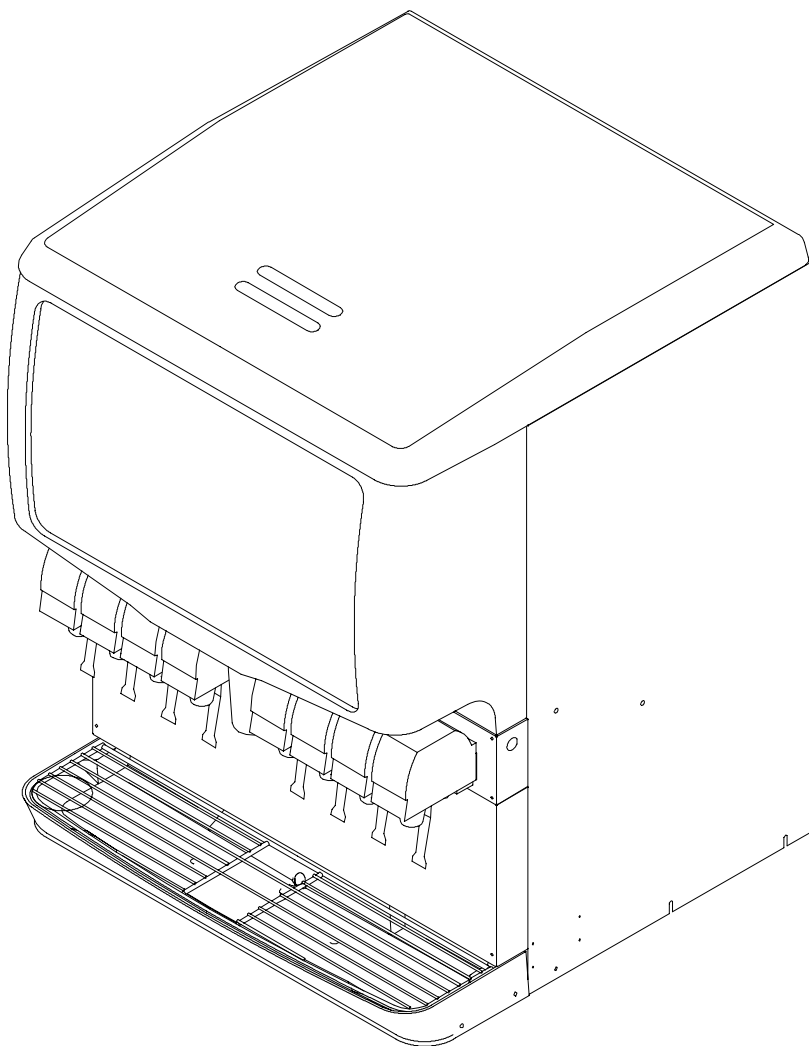

Part No. 92181INS
March 24, 2004
Revised: April 14, 2009
Revision: E

THIS DOCUMENT CONTAINS IMPORTANT INFORMATION

This Manual must be read and understood before installing or operating this equipment

TABLE OF CONTENTS

	Page
SAFETY PRECAUTIONS	1
DESCRIPTION	1
SPECIFICATIONS	1
INSTALLATION INSTRUCTIONS	3
GATE RESTRICTOR PLATE ADJUSTMENT	3
TROUBLESHOOTING	13
BLOWN FUSE OR CIRCUIT BREAKER.	13
GATE DOES NOT OPEN. AGITATOR DOES NOT TURN.	13
GATE DOES NOT OPEN OR IS SLUGGISH. AGITATOR TURNS.	13
ICE DISPENSES CONTINUOUSLY.	13
SLUSHY ICE. WATER IN HOPPER.	13
BEVERAGES DO NOT DISPENSE.	13
BEVERAGES TOO SWEET.	13
BEVERAGE NOT SWEET ENOUGH.	14
BEVERAGES NOT COLD (UNITS WITH BUILT-IN COLD PLATE).	14
FLAVOR SYRUPS DO NOT DISPENSE.	14
FLAVOR DISPENSES FOR MORE THAN 1 SEC.	14
FLAVOR DISPENSES MORE THAN .5 OZ.	14
WARRANTY	15

LIST OF FIGURES

FIGURE 1. DRIP TRAY DRAIN ASSEMBLY	3
FIGURE 2. GATE RESTRICTOR PLATE	4
FIGURE 3. MOUNTING TEMPLATE	4
FIGURE 4. FLOW DIAGRAM ("BC" UNIT WITH SIX BEVERAGE FAUCETS) .	5
FIGURE 5. FLOW DIAGRAM ("BC" UNIT WITH EIGHT BEVERAGE FAUCETS)	6
FIGURE 6. FLOW DIAGRAM ("BC" UNIT WITH TEN BEVERAGE FAUCETS) .	7
FIGURE 7. FLOW DIAGRAM ("B" UNIT WITH EIGHT BEVERAGE FAUCETS)	8
FIGURE 8. WIRING DIAGRAM (115 VOLT UNIT)	9
FIGURE 9. SCHEMATIC (115 VOLT UNIT)	10
FIGURE 10. WIRING DIAGRAM (220-240 VOLT UNIT)	11
FIGURE 11. SCHEMATIC (220-240 VOLT UNIT)	12

SAFETY PRECAUTIONS

Always: Disconnect power to the dispenser before servicing or cleaning.

Never: Place hands inside of hopper or gate area without disconnecting power to the dispenser. Agitator rotation occurs automatically when dispenser is energized!

This ice dispenser has been specifically designed to provide protection against personal injury and eliminates contamination of ice. To insure continued protection and sanitation, observe the following:

ALWAYS: Be sure the removable lid is properly installed to prevent unauthorized access to the hopper interior and possible contamination of the ice.

ALWAYS: Be sure the upper and lower front panels are securely fastened.

ALWAYS: Keep area around the dispenser clean of ice cubes.

This appliance is not intended for use by young children or infirm persons unless they have been adequately supervised by a responsible person to ensure that they can use the appliance safely. Young children should be supervised to ensure that they do not play with the appliance.



CAUTION: Dispenser cannot be used with crushed or flaked ice. Use of bagged ice which has frozen into large chunks can void warranty. The dispenser agitator is not designed to be an ice crusher. Use of large chunks of ice which "jam up" inside the hopper will cause failure of the agitator motor and damage to the hopper. If bagged ice is used, it must be carefully and completely broken into small, cube-sized pieces before filling into the dispenser hopper.

DESCRIPTION

The "ENDURO" series of ice dispensers solves your ice and beverage service needs in a sanitary, space saving, economical way. Designed to be manually filled with ice from any remote ice making source, these dispensers will dispense cubes (up to 1-1/4 in. in size), cubelets, and hard-chipped or cracked ice; and in addition, several flavors of post-mix beverages. The "BC" units include beverage faucets and a cold plate and are designed to be supplied direct from syrup tanks and a carbonator, with no additional cooling required.

SPECIFICATIONS

Model	ED200 (ice only)	ED250 (ice only)
	B (Beverage Faucets)	B (Beverage Faucets)
	C (Cold Plate)	C (Cold Plate)
	Z (No drip tray)	Z (No drip tray)
	N (No Lid)	N (No Lid)
	F (Flavor)	F (Flavor)
	H (Internal Carb)	H (Internal Carb)
Ice storage	200 pounds	250 pounds
Maximum No. of Beverage Faucets Available	10	10
Cold Plate (Built-In)	Yes, On BC Model Only	Yes, On BC Model Only
Electrical	120/1/60, 3.5 Amps 220-240/1/50-60, 2.0 Amps	120/1/60, 3.5 Amps 220-240/1/50-60, 2.0 Amps
Dimensions	30 in. Wide X 30-11/16 in. Deep X 35-5/8 in. High	30 in. Wide X 30-11/16 in. Deep X 39-5/8 in. High
Z Model	30 in. Wide X 23-1/16 in. Deep X 35-5/8 in. High	30 in. Wide X 23-1/16 in. Deep X 39-5/8 in. High

INSTALLATION INSTRUCTIONS

1. Locate the dispenser indoors on a level counter top.

A. LEG OPTION

Note: Before installing legs, the plastic plugs must be removed.

Unpack the four (4) legs and install them into the threaded holes provided in the bottom of the unit. The installer must provide flexibility in the product and utility supply lines to permit shifting the position of the dispenser sufficiently to clean the area beneath it.

Rotate the line support bracket, located under base, to the down position and route all the lines above the bracket.

B. COUNTER MOUNTING

The ice dispenser must be sealed to the counter. The MOUNTING TEMPLATE (see Figure 3) indicates where openings can be cut in the counter. Locate the desired position for the dispenser, then mark the outline dimensions on the counter using the MOUNTING TEMPLATE. Cut openings in the counter.

Rotate the line support bracket, located under base, to the up position and route all the lines below the bracket.

Apply a continuous bead of National Sanitation Foundation (NSF) listed silastic sealant (Dow 732 or equal) approximately 1/4" inside of the unit outline dimensions and around all openings. Then, position the unit on the counter within the outline dimensions. All excess sealant must be wiped away immediately.

2. The beverage tubes, drain tube and power cord are routed through the large opening in the bottom of the unit. See the MOUNTING TEMPLATE (see Figure 3), for locating the required clearance hole in the counter for these utility lines.
3. DRIP TRAY DRAIN ASSEMBLY (see Figure 1). Route the drain tube to an open drain with the end of the tube above the "flood" level of the drain. Use the tubing, fittings, clamps, and insulation provided with the Dispenser to assemble the drain. The completed drain line *must* pitch continuously downward and contain no "traps" or improper drainage will result.

NOTE: This equipment must be installed with adequate backflow protection to comply with federal, state, and local codes.

4. Connect the beverage system product tubes as indicated in the applicable Flow Diagram. This work should be done by a qualified Service Person. Any non-carbonated water tubing must be connected to the outlet of the check valve.

Note: See applicable Flow Diagram (see Figure 4 through 7) or decal on lower front panel of the unit for the location of syrup and water connections.

Note: Water pipe connections and fixtures directly connected to a potable water supply shall be sized, installed and maintained according to Federal, State and Local Laws.

5. Clean the hopper interior (see Owner's Manual P/N 92108 for cleaning instructions).
6. Connect the power cord to a 120 volt, 60 cycle, 3-wire grounded receptacle. For 220-240 volt units, a 3-wire power cord is provided. An adapter plug for the particular country will need to be provided by the equipment Installer.
7. Maximum and minimum ambient temperature rating for correct operation is 40 to 105°F.
8. The unit is not suitable for installation in an area where a water jet could be used.
9. The unit has to be placed in a horizontal position.
10. If the supply cord is damaged, it must be replaced by the manufacturer, its service agent or similarly qualified persons in order to avoid a hazard.

GATE RESTRICTOR PLATE ADJUSTMENT



CAUTION: Disconnect power to dispenser before installing, removing or adjusting restrictor.

The restrictor plate may be adjusted up or down as shown in Figure 2 to reduce or increase the ice dispensing rate, especially desirable when using glasses or other containers with small openings. Adjustment can be made by sliding the restrictor plate up or down with nuts loosened, to obtain the desired ice dispensing rate.

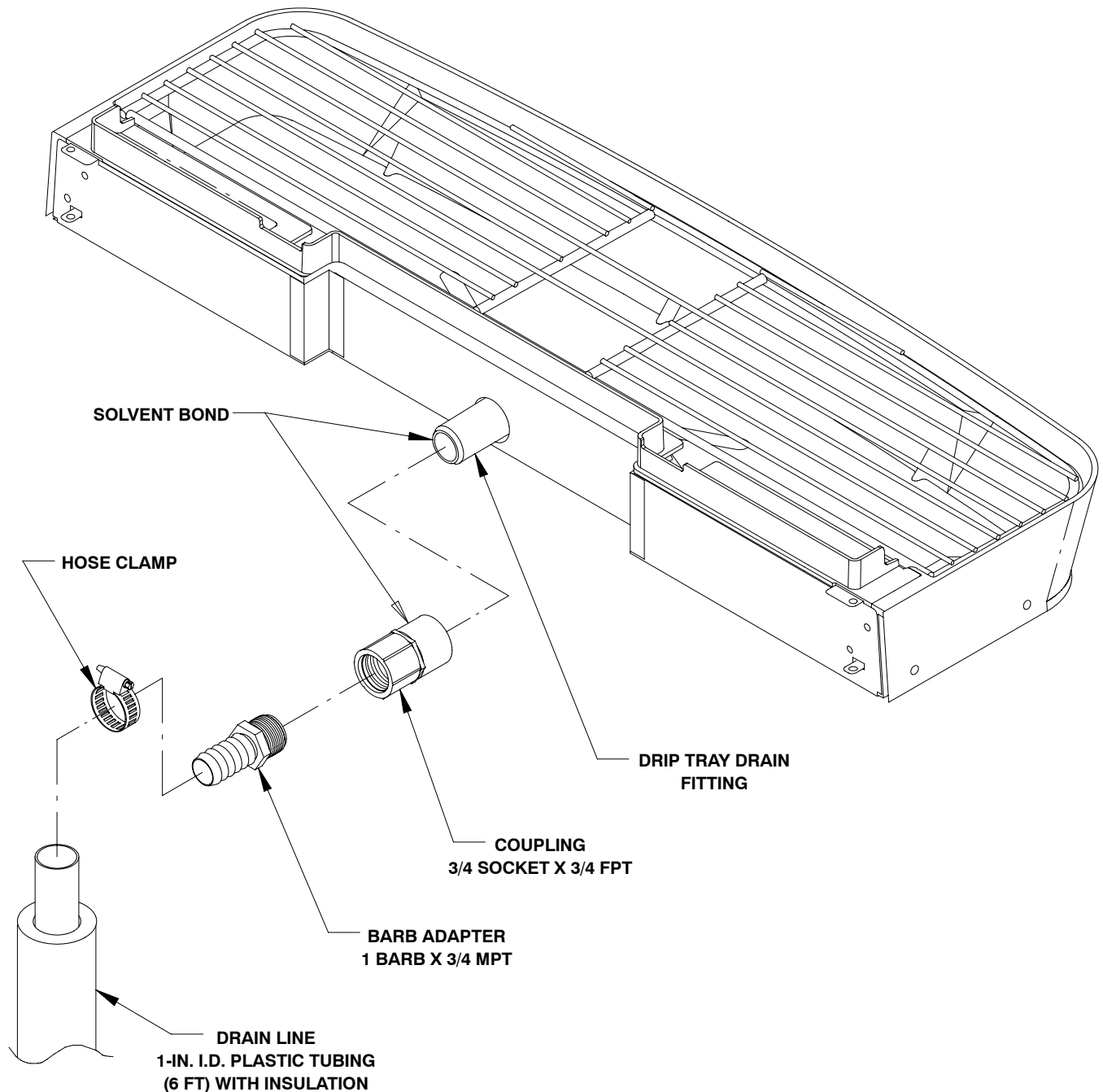
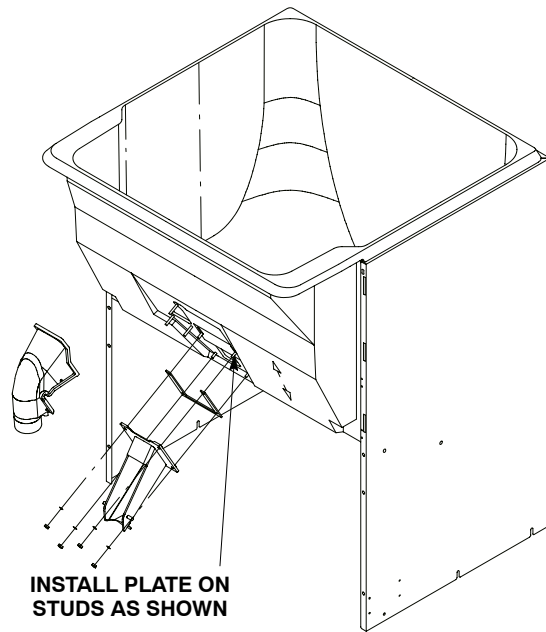

FIGURE 1. DRIP TRAY DRAIN ASSEMBLY



INSTALL PLATE ON STUDS AS SHOWN

FIGURE 2. GATE RESTRICTOR PLATE

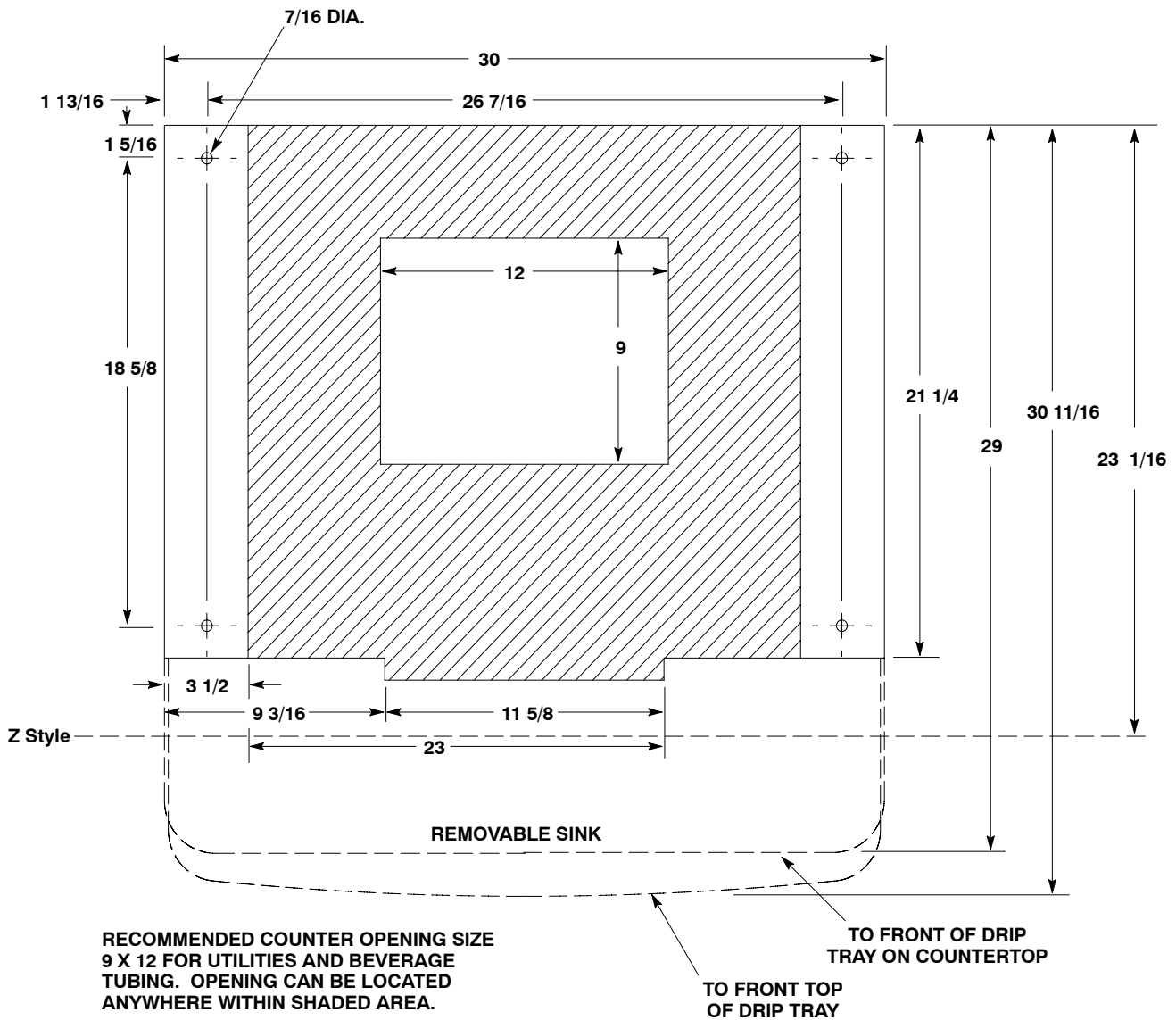

FIGURE 3. MOUNTING TEMPLATE

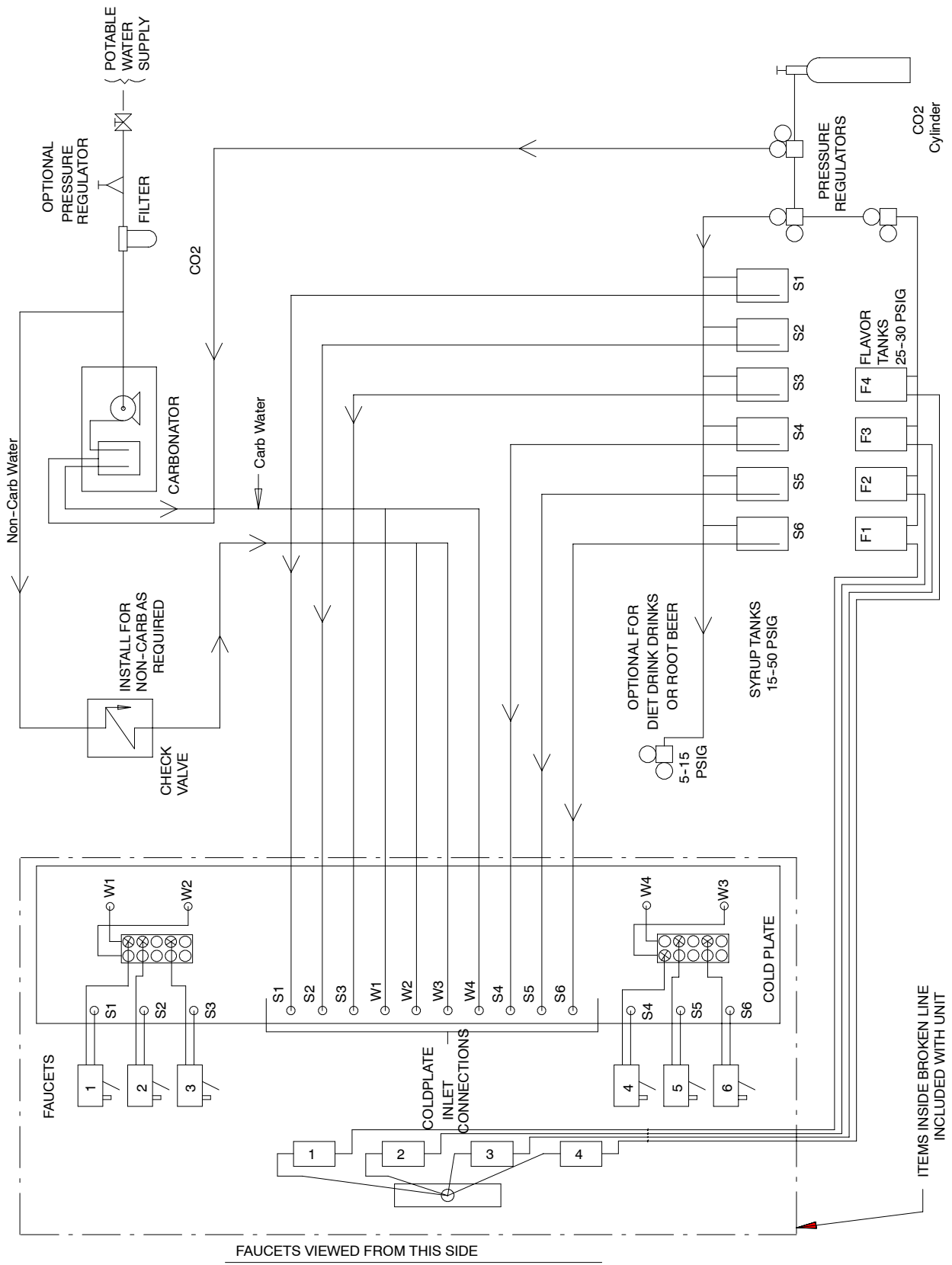

FIGURE 4. FLOW DIAGRAM (UNIT WITH SIX FAUCETS)

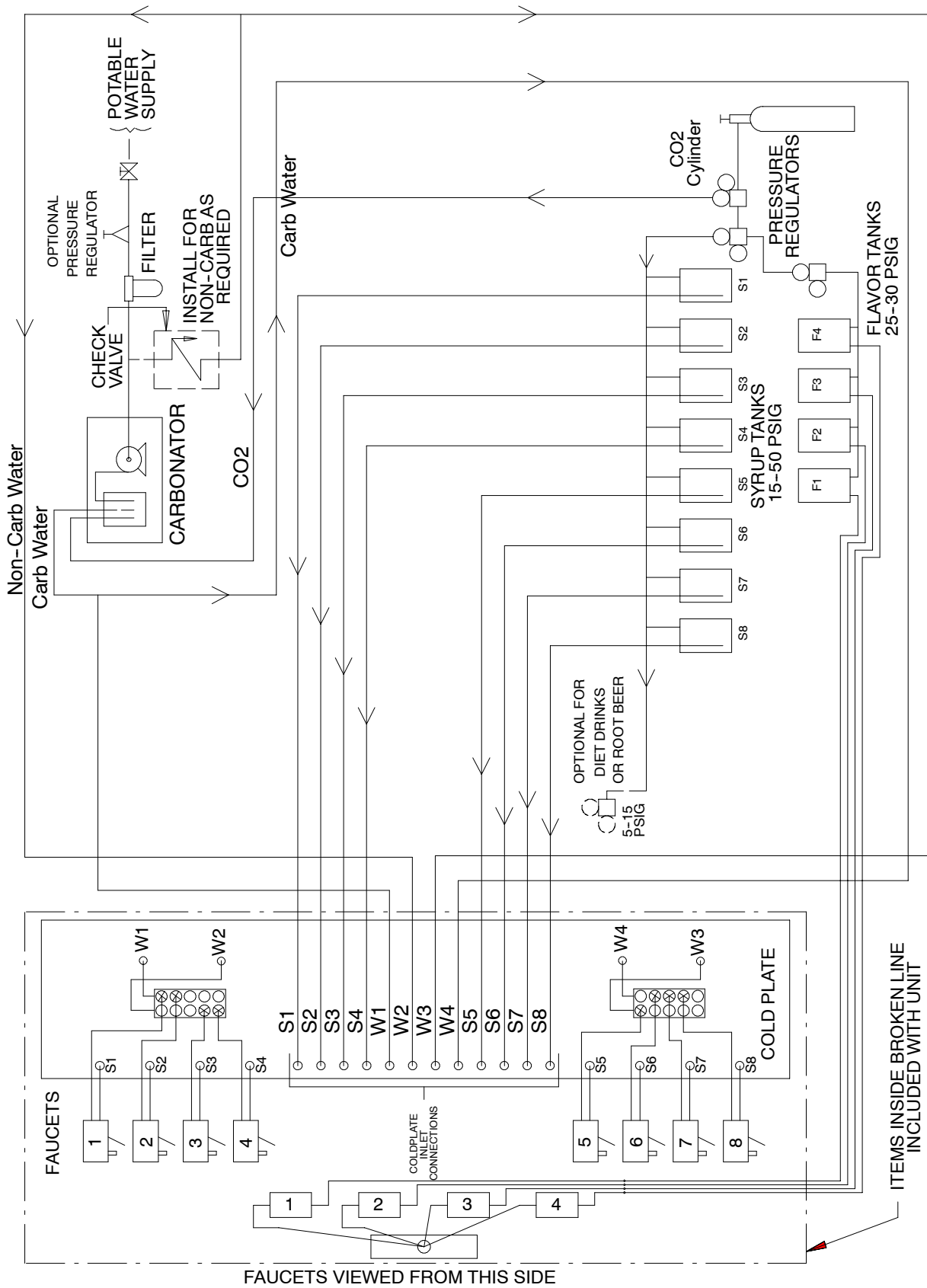
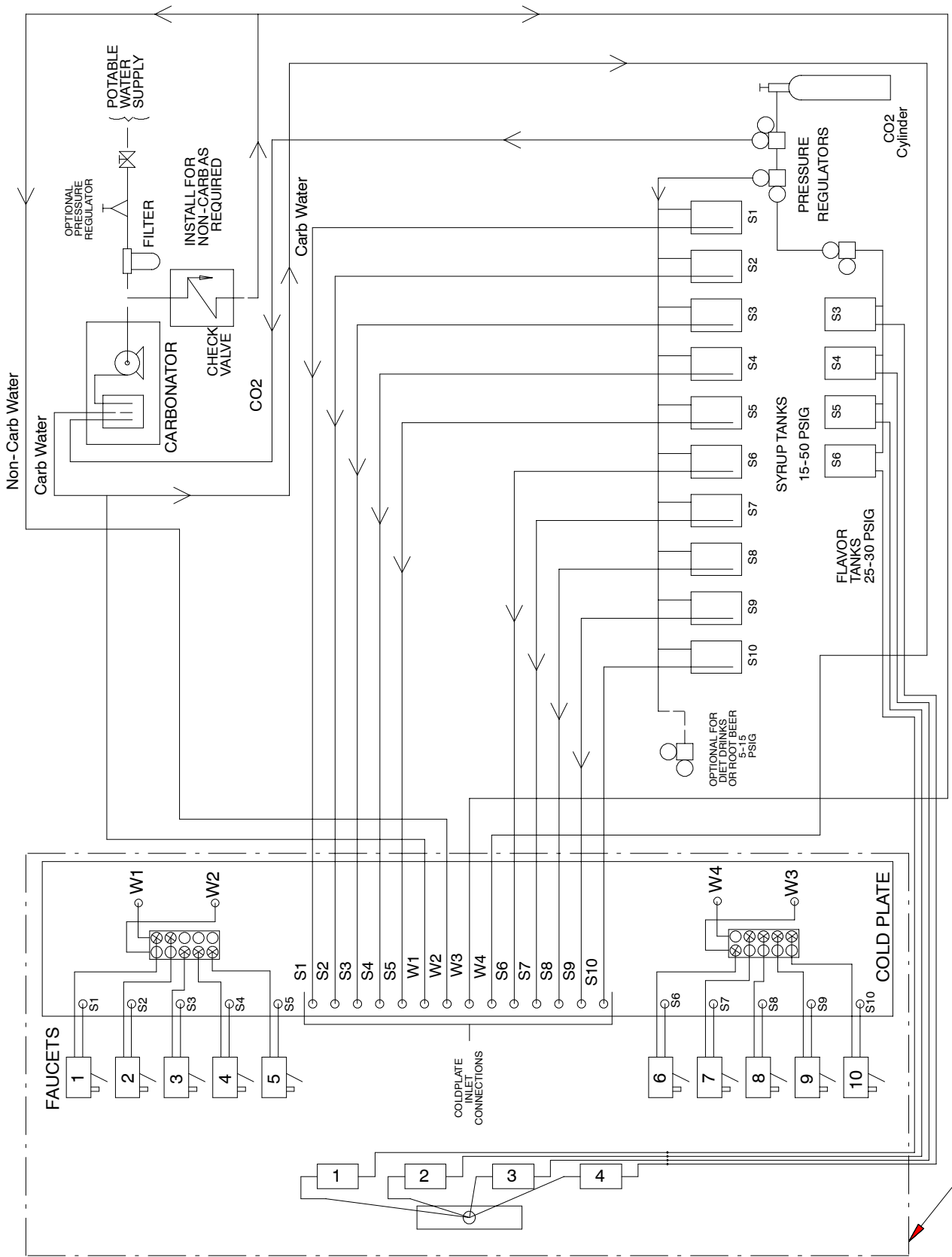

FIGURE 5. FLOW DIAGRAM (UNIT WITH EIGHT FAUCETS)



FAUCETS VIEWED FROM THIS SIDE
FIGURE 6. FLOW DIAGRAM (UNIT WITH TEN FAUCETS)

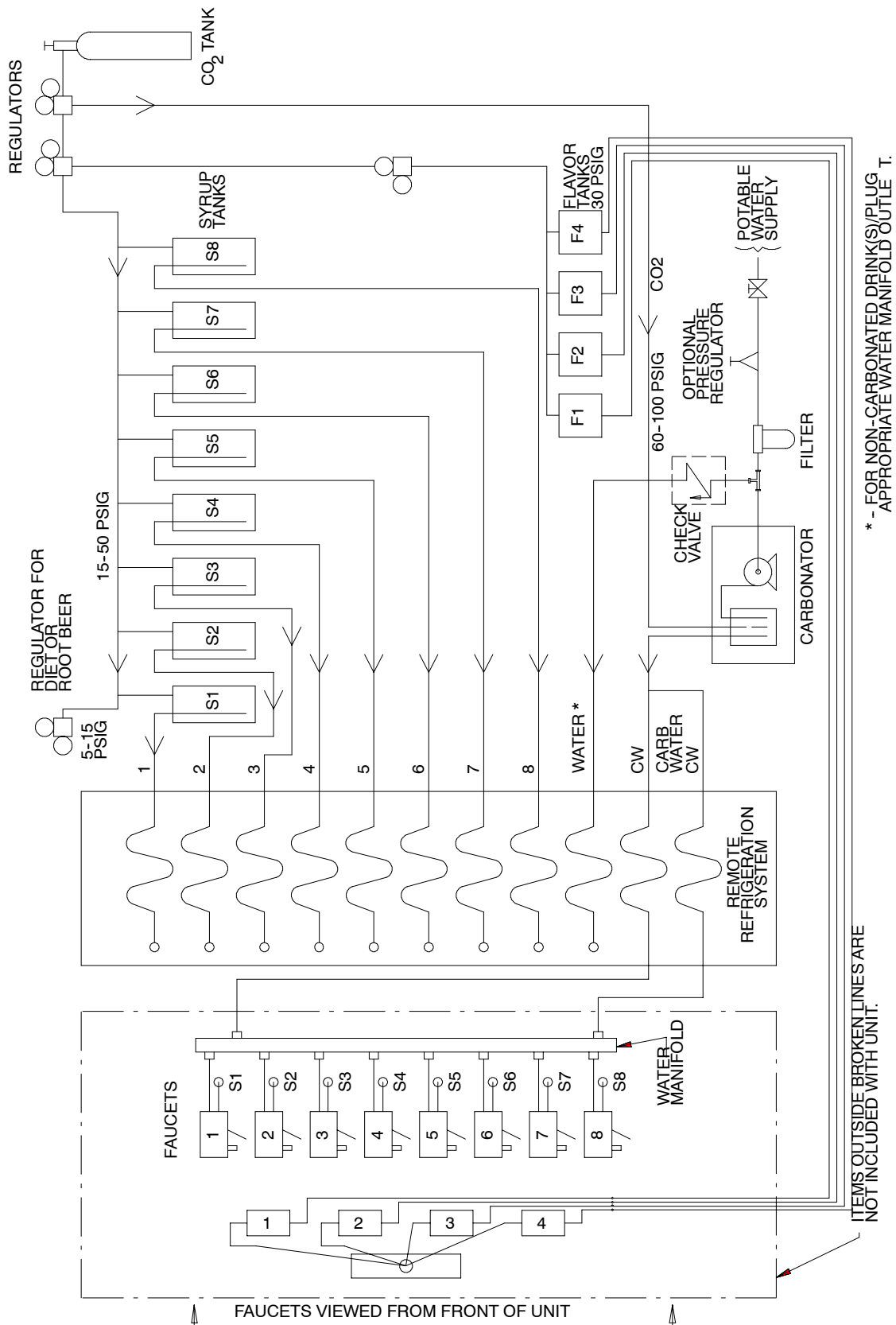

FIGURE 7. FLOW DIAGRAM ("B" UNIT WITH EIGHT BEVERAGE FAUCETS)

* - FOR NON-CARBONATED DRINK(S)/PLUG, APPROPRIATE WATER MANIFOLD OUTLET 1.

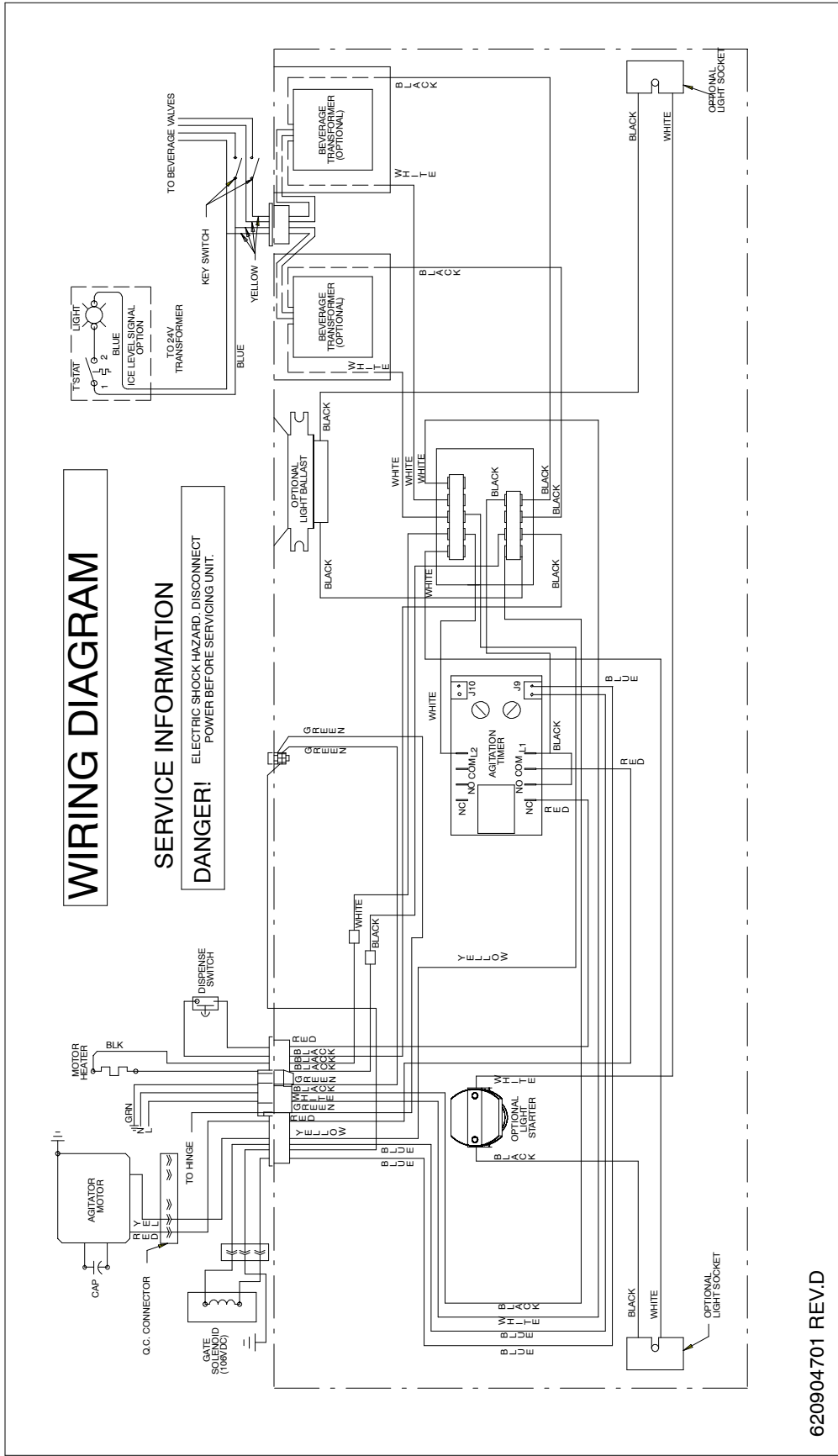

FIGURE 8. WIRING DIAGRAM (115 VOLT UNIT)

620904701 REV.D

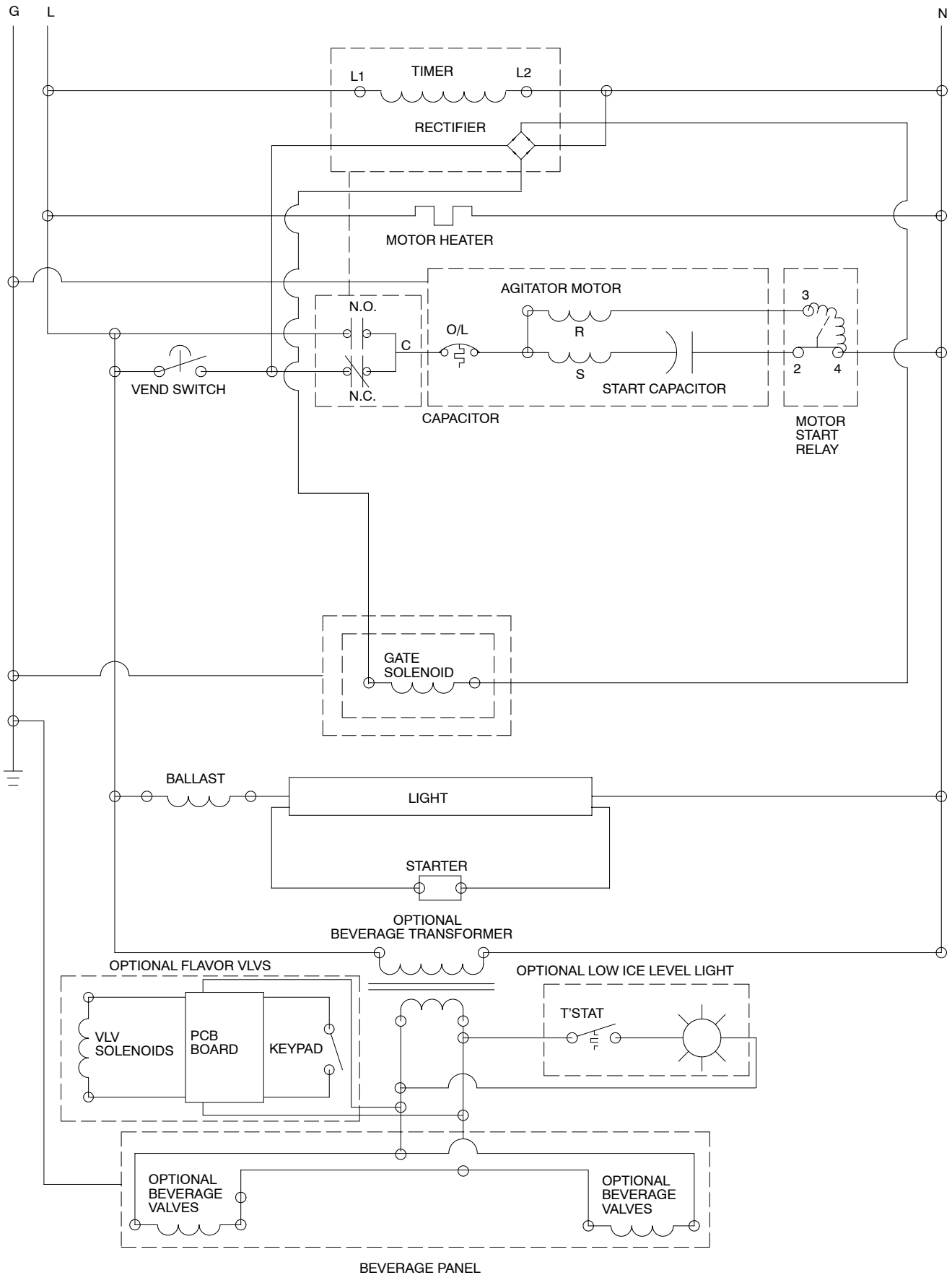

FIGURE 9. SCHEMATIC (115 VOLT UNIT)

WIRING DIAGRAM

SERVICE INFORMATION

(220-240 VAC)

DANGER! ELECTRIC SHOCK HAZARD. DISCONNECT POWER BEFORE SERVICING UNIT.

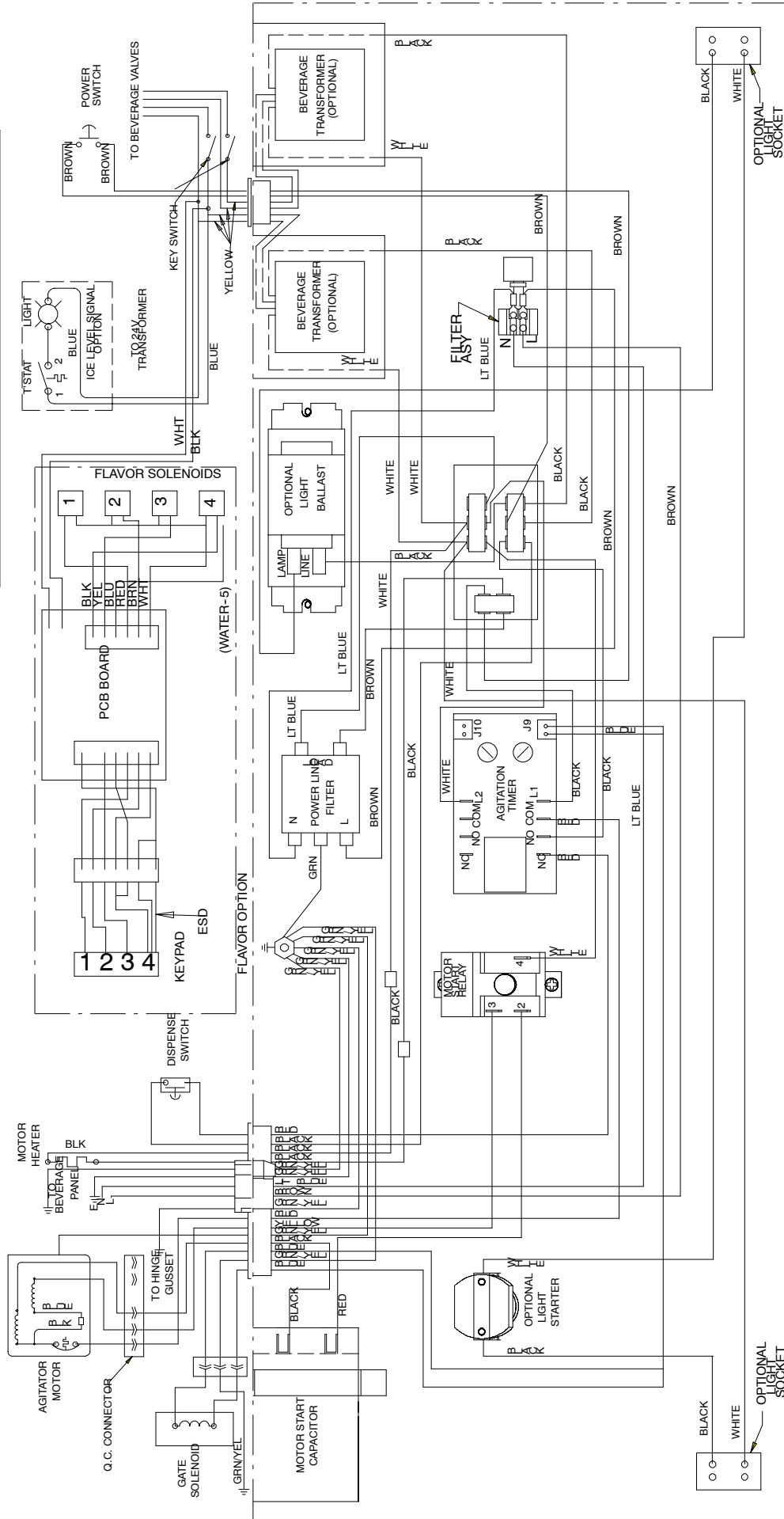

FIGURE 10. WIRING DIAGRAM (220-240 VOLT UNIT)

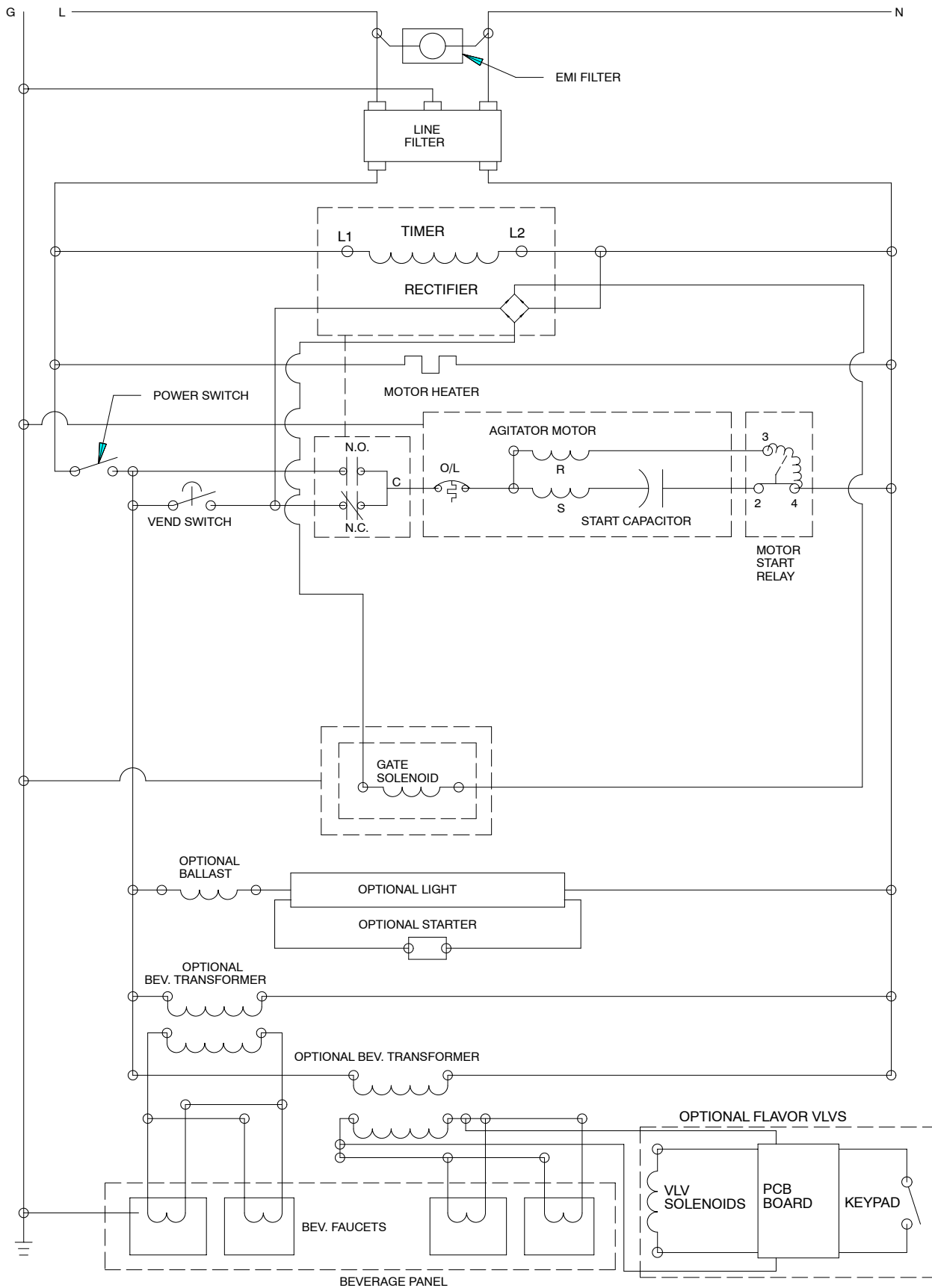

FIGURE 11. SCHEMATIC (220-240 VOLT UNIT)

TROUBLESHOOTING

IMPORTANT: Only qualified personnel should service internal components or electrical wiring.



WARNING: If repairs are to be made to a product system, remove quick disconnects from the applicable product tank, then relieve the system pressure before proceeding. If repairs are to be made to the CO₂ system, stop dispensing, shut off the CO₂ supply, then relieve the system pressure before proceeding. If repairs are to be made to the refrigeration system, make sure electrical power is disconnected from the unit.

Should your unit fail to operate properly, check that there is power to the unit and that the hopper contains ice. If the unit does not dispense, check the following chart under the appropriate symptoms to aid in locating the defect.

Trouble	Probable Cause
BLOWN FUSE OR CIRCUIT BREAKER.	<ul style="list-style-type: none"> A. Short circuit in wiring. B. Defective gate solenoid. C. Defective agitator motor.
GATE DOES NOT OPEN. AGITATOR DOES NOT TURN.	<ul style="list-style-type: none"> A. No power. B. Bent depressor plate (does not actuate switch). C. Defective dispensing switch.
GATE DOES NOT OPEN OR IS SLUGGISH. AGITATOR TURNS.	<ul style="list-style-type: none"> A. Defective gate solenoid. B. Excessive pressure against gate slide. C. Defective Rectifier.
ICE DISPENSES CONTINUOUSLY.	<ul style="list-style-type: none"> A. Stuck or bent depressor plate (does not release switch). B. Defective dispensing switch. C. Improper switch installation.
SLUSHY ICE. WATER IN HOPPER.	<ul style="list-style-type: none"> A. Blocked drain. B. Unit not level. C. Poor ice quality due to water quality or icemaker problems. D. Improper use of flaked ice.
BEVERAGES DO NOT DISPENSE.	<ul style="list-style-type: none"> A. No 24 volt power to faucets. B. No CO₂ pressure.
BEVERAGES TOO SWEET.	<ul style="list-style-type: none"> A. Carbonator not working. B. No CO₂ pressure in carbonator. C. Faucet brix requires adjusting.

Trouble	Probable Cause
BEVERAGE NOT SWEET ENOUGH.	A. Empty syrup tank. B. Faucet brix requires adjusting.
BEVERAGES NOT COLD (UNITS WITH BUILT-IN COLD PLATE).	A. Unit standing with no ice in hopper or no ice in cold plate cabinet.
FLAVOR SYRUPS DO NOT DISPENSE.	A. No 24 volt power to PC board. B. No CO2 pressure. C. Empty syrup tank. D. Kinked tubing. E. Clogged inner nozzle. F. Defective PC board. G. Defective harness from keypad. H. Defective Flow control. I. Defective solenoid harness. J. Defective keypad.
FLAVOR DISPENSES FOR MORE THAN 1 SEC.	A. Dip switch settings on control board incorrect. B. PC board defective. C. Defective flow control.
FLAVOR DISPENSES MORE THAN .5 OZ.	A. Dip switch settings on control board incorrect. B. Flow control incorrectly set. C. PC board defective. D. Defective flow control.

Contact your local syrup or beverage equipment distributor for additional information and troubleshooting of beverage system.



WARRANTY

IMI Cornelius Inc. warrants that all equipment and parts are free from defects in material and workmanship under normal use and service. For a copy of the warranty applicable to your Cornelius product, in your country, please write, fax or telephone the IMI Cornelius office nearest you. Please provide the equipment model number and the date of purchase.

IMI Cornelius Offices

AUSTRALIA ● P.O. 210, ● RIVERWOOD, ● NSW 2210, AUSTRALIA ● (61) 2 533 3122 ● FAX (61) 2 534 2166
AUSTRIA ● AM LANGEN FELDE 32 ● A-1222 ● VIENNA, AUSTRIA ● (43) 1 233 520 ● FAX (43) 1-2335-2930
BELGIUM ● BOSKAPPELLEI 122 ● B-2930 BRAASCHAAT, BELGIUM ● (32) 3 664 0552 ● FAX (32) 3 665 2307
BRAZIL ● RUA ITAOCARA 97 ● TOMAS COELHO ● RIO DE JANEIRO, BRAZIL ● (55) 21 591 7150 ● FAX (55) 21 593 1829
ENGLAND ● TYTHING ROAD ALCESTER ● WARWICKSHIRE, B49 6 EU, ENGLAND ● (44) 789 763 101 ● FAX (44) 789 763 644
FRANCE ● 71 ROUTE DE ST. DENIS ● F-95170 DEUIL LA BARRE ● PARIS, FRANCE ● (33) 1 34 28 6200 ● FAX (33) 1 34 28 6201
GERMANY ● CARL LEVERKUS STRASSE 15 ● D-4018 LANGENFELD, WEST GERMANY ● (49) 2173 7930 ● FAX (49) 2173 77 438
GREECE ● 488 MESSOGION AVENUE ● AGIA PARASKEVI ● 153 42 ● ATHENS, GREECE ● (30) 1 600 1073 ● FAX (30) 1 601 2491
HONG KONG ● 1104 TAIKOTSUI CENTRE ● 11-15 KOK CHEUNG ST ● TAIKOKTSUE, HONG KONG ● (852) 789 9882 ● FAX (852) 391 6222
ITALY ● VIA PELLIZZARI 11 ● 1-20059 ● VIMARCATI, ITALY ● (39) 39 608 0817 ● FAX (39) 39 608 0814
NEW ZEALAND ● 20 LANSFORD CRES. ● P.O. BOX 19-044 AVONDALE ● AUCKLAND 7, NEW ZEALAND ● (64) 9 8200 357 ● FAX (64) 9 8200 361
SINGAPORE ● 16 TUAS STREET ● SINGAPORE 2263 ● (65) 862 5542 ● FAX (65) 862 5604
SPAIN ● POLIGONO INDUSTRIAL ● RIERA DEL FONOLLAR ● E-08830 SANT BOI DE LLOBREGAT ● BARCELONA, SPAIN ● (34) 3 640 2839 ● FAX (34) 3 654 3379
USA ● ONE CORNELIUS PLACE ● ANOKA, MINNESOTA ● (763) 421-6120 ● FAX (763) 422-3255