

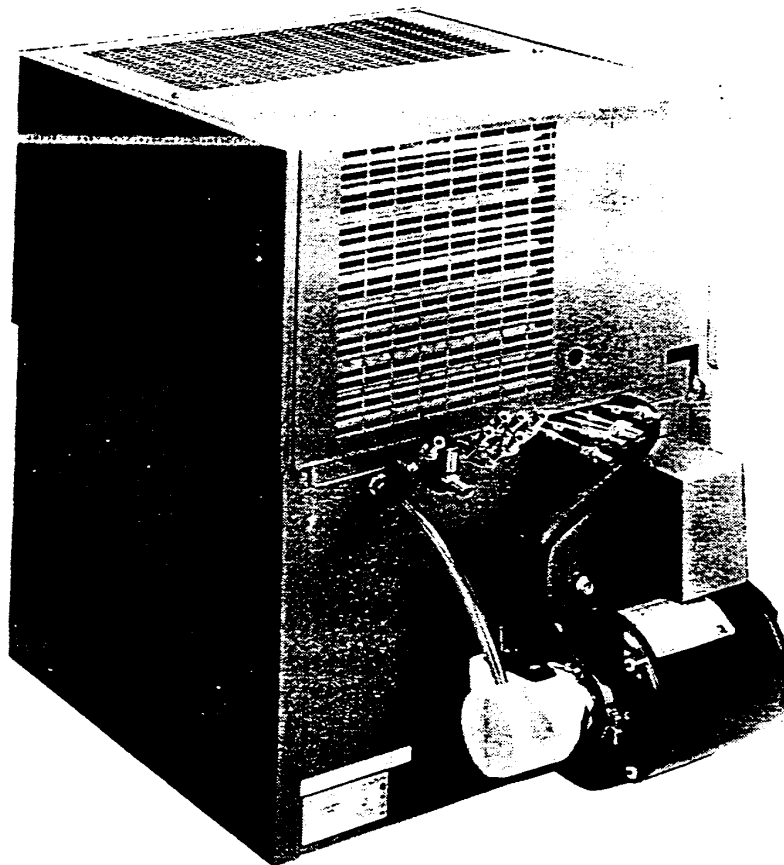

REMOTE COOLING UNIT

UC-40 and UCC-40

Installation and Service Manual



Release Date: September 28, 2004

Publication Number: 710160089

Revision Date: N/A

Revision: N/A

Visit the IMI Cornelius web site at www.cornelius.com for all your Literature needs.



INSTALLATION AND SERVICE MANUAL

The products, technical information, and instructions contained in this manual are subject to change without notice. These instructions are not intended to cover all details or variations of the equipment, nor to provide for every possible contingency in the installation, operation or maintenance of this equipment. This manual assumes that the person(s) working on the equipment have been trained and are skilled in working with electrical, plumbing, pneumatic, and mechanical equipment. It is assumed that appropriate safety precautions are taken and that all local safety and construction requirements are being met, in addition to the information contained in this manual.

To inquire about current revisions of this and other documentation or for assistance with any Cornelius product contact:

www.cornelius.com
800-238-3600

Trademarks and copyrights:

Aurora, Cornelius, Decade, Hydro Boost, Sitco, Spirit, UF-1, Vanguard, Venture, Olympus, and Vista are registered trademarks of IMI Cornelius Inc.

Optifill trademark is pending.

This document contains proprietary information and it may not be reproduced in any way without permission from Cornelius.

Printed in U.S.A.

Copyright © 2004, All Rights Reserved, IMI Cornelius, Inc.

IMPORTANT INFORMATION AND SAFETY NOTES. PLEASE READ BEFORE INSTALLING DISPENSER.

- Always transport equipment in an upright position and never drag over rough floors or down steps.
- A trained person, who is qualified to make connections to water, electrical and/or compressed gas supplies must only carry out installation and maintenance. Local by-laws/regulations must be followed.
- Switch off and unplug electrical power to unit during maintenance operations. Do not attempt to remove any protective covers.
- Locate equipment on a firm, level surface and protect from physical damage. Mounting surface must be able to support 500 lbs. (227kg) weight. Never allow air vents/louvers to become blocked and do not place any non-specified items on top. Regularly clean condensers and louvers with a soft brush or vacuum.
- This dispenser is for indoor use only. Do not expose equipment to extremes of temperature, water spillage, spray, steam, or high humidity or clean with water jet into dispenser components because this could cause damage to electrical components and shock to personnel. Do not place or store objects on top of unit.
- This dispenser must be connected to correctly rated electrical power outlet, preferably protected by a safety cutout and is easily accessible for isolation of the equipment. The equipment must be earth grounded.
 - Use and ELCB (earth leakage circuit breaker)/GFCI (ground fault interrupt) for electrical power protection.
 - Use an HVAC circuit breaker to the power outlet circuit supplying the dispenser.
 - Each module or accessory requires a 120 VAC 15 Amp 60 HZ grounded outlet. If 230 VAC 50/60 HZ, use a minimum of 10 Amp outlet for each module or accessory.
- Ambient temperature must not exceed 90°F (32.3°C) on units with merchandisers.

WATER SYSTEM

- Insufficient water supply to carbonator will cause pump damage.

WARNING: If the installation is idle and exposed to freezing temperatures, disconnect water supply lines and blow out all water from pump, carbonator tank, and dispensing system.

WARNING: UNDETECTED CO2 LEAKS MAY CAUSE HARM OR DEATH DUE TO ASPHYXIATION. CO2 tank must be located next to a solid wall and chained to the wall. CO2 cylinders must be secured in a vertical position and only connected to dispensing equipment via a suitable pressure regulator. Check connections for leaks.

WARNING: DO NOT lift dispenser modules by valve housing assemblies. Lifting by the valve housing assemblies will cause damage to the housing.

WARNING: System must be sanitized in accordance with the procedures found in this manual under the cleaning and maintenance section.

WARNING: Before attempting to remove the refrigeration deck, disconnect all electrical power. Melt the ice bank and thoroughly drain the water bath. See additional notes in Water Bath Cleaning Section in the manual.

SPECIFICATIONS

DIMENSIONS

See Illustration Below

SHIPPING WEIGHT

135 lbs. (61.4 kg)

OPERATING WEIGHT

241 lbs. (109.5 kg)

ELECTRICAL RATING

115 VAC/60HZ/14.6 AMPS; 220VAC/50-60HZ/7.3 AMPS

Transformer: (Built In) 24VAC Secondary

REFRIGERATION

1/3 HP (Lift Out Type)

Condenser: Air Cooled

Refrigerant: R134a

APPROVAL

U.L., C.S.A., N.S.F.

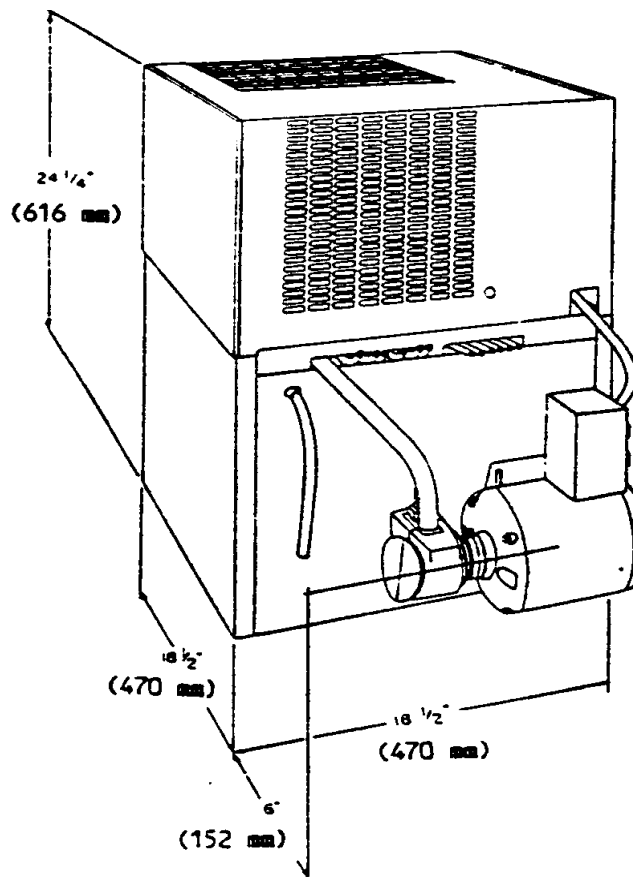

MECHANICAL SERVICE REQUIREMENTS

LOCATION

The dispenser will tolerate a surface +/- 1/2° or +/- 1/8" per foot or +/- 10.4mm per meter maximum slope without affecting refrigeration capacity or cause water spillage from water bath.

Do not install dispenser next to any heat producing equipment such as furnaces, ovens, deep-fat fryers.

Never store items on top of dispenser which will restrict the air flow through the air-cooled condenser coil.

Clearance: The space above the dispenser must have a minimum of 16 inches (406mm). Of clearance to allow for the removal of the top cover and refrigeration chassis and to provide adequate ventilation.

There should be at least 1 inch (25.4mm) of clearance on each side and to the rear of the dispenser for servicing and ventilation.

ELECTRICAL

The electrical power supply should conform with that printed on dispenser name plate.

All other electrical connections are to comply with local codes.

A wiring diagram can be found in Section 7.0 of this instruction manual.

A separate electrical circuit with a minimum rating equal to the electrical ratings shown on the dispenser nameplate (amperage and voltage) is recommended for satisfactory operation.

WATER SUPPLY & DRAINAGE

A water supply having a 1/2" O.D. (12.7mm) copper water tube, minimum is required with a minimum 20 PSIG (1.4 bar) line pressure.

A shut-off valve within three feet (1 meter) of the unit is recommended.

A suitable water filter is recommended to ensure top quality drinks.

A water pressure regulator or reducing valve should be installed in line to the main water supply and set at 30 to 40 psi (2.1 to 2.8 bar). By limiting the incoming water pressure, a 15 psi (1.05 bar) pressure differential (water pressure versus higher carbonator CO₂ gas pressure) will ensure that flooding of the carbonator tank does not occur.

Teflon pipe tape should be used (as required) on any fittings used in the water system.

Any contaminants such as dirt, cutting oil, pipe dope left in the system may affect the quality of the finished drink. Therefore, flush water lines prior to start up.

CARBON DIOXIDE (CO₂) GAS SUPPLY TO CARBONATOR

For the product tank supply line use a CO₂ regulator capable of 0 psig to 100 psig (6.8 bar) normal working pressure. Recommended setting 75 psi (5.17 bar).

A minimum CO₂ gas supply pressure 15 psi (1.05 bar) greater than the incoming water pressure will ensure that flooding of the carbonator tank will not occur.



SYRUP COMPONENTS

Syrup containers, sold as an accessory, are stainless steel with a capacity of five gallons (18.9 liters). They are equipped with a CO2 gas quick disconnect fitting and syrup quick disconnect fitting.

The dispenser's syrup outlets are 1/4" (6.4mm) barb fittings, and are located at the front wall, mid-height, of the dispenser.

Each syrup inlet is labeled with the valve number that it services.

If the "syrup in" lines need replacement or extension, a .265 I.D. (6.7 mm I.D.) polytube is recommended. Avoid using soft or easily collapsible tubing on the "syrup in" lines.

Only stainless steel or plastic, barb or compression type fittings should be used on any syrup or soda water connections.

Optional bag-in-box system is also suitable for use with this beverage cooler.

INSTALLATION AND START UP PROCEDURE

1. Remove dispenser and related parts from the corrugated shipping carton.
2. Locate dispenser at point of operation.
3. Connect the building's electrical supply to the dispenser's main power box (see wiring diagram).
4. It is recommended that the unit's drain be permanently plumbed to the building drain and conform to all plumbing codes and regulations.
5. Remove the dispenser's top cover by removing two screws found on the top surface of cover.
6. Remove the filler cap found on the refrigeration platform. Pour clean cool water through the filler hole until water is seen flowing from the overflow tube which is connected to the building's plumbing system. Replace filler cap and top cover.
7. Now start the refrigeration system by plugging the system's main power cord into the outlet provided in the cabinet's main electrical box.
8. It is normal to see a small amount of water being displaced from the water bath through the overflow tube as the ice bank is built.
9. A generalized fluid/gas diagram is provided at the end of this manual.
10. Position the CO₂ gas tank in a secure location. Assemble high pressure regulator to CO₂ gas cylinder and run jumper line to low pressure regulator.
11. Position the syrup tanks or bag-in-box components in the desired location. Attach the CO₂ gas lines leading from the low pressure regulator to these tanks, or B.I.B. manifold.
12. Connect syrup lines from tanks or bag-in-box system to the appropriate inlets at the front of the unit. The syrup outlet lines from the cooling unit to the dispensing tower(s) are now connected using (normally .265" I.D.) insulated polytubing conduit.
13. The low pressure gas regulator which controls the flow of syrup to each dispensing valve is normally set at 25 psig to 35 psig (1.75 to 2.45 bar) or as required for proper operation of the valve. For diet type syrup, the tank pressures should be set at from 3 to 8 psi (.21 to .56 bar) or as recommended by the syrup supplier. Additional pressure may be necessary depending on the distance from the syrup tank to the unit.
14. Mount the water filter assembly (if used) and water regulator in a convenient location.
15. Connect water inlet line to water regulator, set at 30 to 40 psig (2.1 to 2.8 bar), to water filter, and then to the 3/8" (9.5mm) barbed water inlet of the UCC-40.
16. Connect a (.265" I.D.) (6.7mm I.D.) CO₂ gas line from the high pressure CO₂ regulator to the 1/4" (6.4mm) barbed "CO₂ Supply Connection" fitting at the UCC-40. This fitting supplies CO₂ gas to the built-in carbonator tank. The normal setting range of the high pressure CO₂ gas regulator is 55 to 80 psi (3.85 to 5.6 bar), but may be set as high as 100 psi (7 bar).
17. The soda water outlet fitting of the UCC-40 (a pump with tag) is connected to the dispensing tower(s) using the 3/8" I.D. (9.5mm I.D.) line of an insulated polytubing conduit.
18. The recirculating (return) soda water from the dispensing tower(s) is connected to the 3/8" (9.5mm) barb fitting (tag) of the UCC-40 using a 3/8" I.D. (9.5mm) line of an insulated polytubing conduit.
19. After all connections to water, CO₂ gas, electrical power and syrup containers are made, check for leaks.
20. Be sure syrup tanks or BIB boxes contain syrup.
21. Turn on water. Open the pressure relief valve on the carbonator tank by lifting the wire ring, and hold it open until water flows from the relief valve. Close the relief valve and turn on the CO₂ gas and electrical power in that order. DO NOT operate carbonator pump with water supply shut off.
22. To fill all lines with carbonated water, cycle the carbonator several times by operating the dispensing valves. If valves do not operate check that the valve switch it "ON".
23. The recirculating soda water "pump/motor" is controlled by the rocker switch at the unit's electrical box identified as "RECIRC. PUMP SWITCH". This switch is now turned "ON".
24. The dispensing valves should be adjusted in accordance to the instructions of the dispensing tower or valve manufacturer.

ICE BANK CONTROL REPLACEMENT

1. Disconnect power to dispenser.
2. Remove cap from drain tube and position the drain tube in the drain pan and drain the water bath.
3. Refill water bath with warm water at a temperature of 120°F (49°C). Let stand for ten (10) minutes to melt ice bank. If ice remains, repeat Steps 2 and 3 until all ice is melted. Failure to melt all ice may cause the dispenser to freeze-up after the new ice bank control is installed.
4. Remove two screws from dispenser top and remove top.
5. Remove old ice bank control.
6. Install new ice bank control by pushing probe down into the 3/4" tube until it stops on the bottom of the tube. Secure probe with tape.
7. Fill water bath with fresh water. Replace dispenser top and secure with two screws.
8. Connect dispenser to power source and turn ON.

CLEANING AND MAINTENANCE

NOTE: The dispenser must be cleaned and sanitized after installation and, thereafter, as required by state and local health departments, or every three months minimum.

Continuous maintenance of this unit is a basic requirement for proper operation and sanitation, including all support equipment utilized in the daily operation of this equipment.

1. On a daily basis, clean the external cabinet (splash areas) with mild soap and warm water. Wash the cup rest and drip pan in cleaning solution and rinse with warm tap water. DO NOT use strong bleach or detergents or they may discolor and corrode the cabinet materials. DO NOT use steel wool or other abrasive scouring pads.
2. DO NOT use excessively hot water which may cause damage to plastic components.
3. The water bath should be cleaned two to four times annually, depending upon local water conditions and in accordance with state and local health departments.
4. Cleaning of the refrigeration components should be performed by a qualified service person. Disconnect power before removing the dispenser top. The dispenser top grilles should be cleaned periodically to maintain efficient refrigeration. Condenser fins should be combed, if needed, to maintain adequate circulation. Clogged condensers can lead to premature compressor failure.

SANITIZING, CLEANING, & MAINTENANCE

This section details the following:

- A. Sanitizing of System
- B. Daily Cleaning
- C. Ice Water Bath Maintenance

It will be necessary to periodically check and correct the water level of the water bath.

The frequency of filling will depend on the environment within which the dispenser is operating and consequently, the degree of evaporation of water.

Noisy operation and/or reduced cooling capacity can be caused by insufficient water in the water bath.

The condenser coil will require periodical cleaning to ensure correct air flow and cooling at the condenser. The frequency of cleaning will depend on the environment within which the dispenser operates.

All refrigeration components have been factory lubricated for life-time service and will require no further lubrication.

CLEANING AND SANITIZING PROCEDURE

Water Circuits: Cleaning and sanitizing is not required for potable water circuits. Potable water lines should remain connected and operational during the cleaning and sanitizing procedures for syrup circuits.

NOTE: Carbonated Water Lines must remain connected and operational during cleaning and sanitizing of the syrup circuits. Sanitizing of the valve without the carbonated water side operational, may leave bacteria in the nozzle, diffuser, and syrup tube.

CLEANING EQUIPMENT AND SUPPLIES

- Recommended cleaner: A.C. Fergusson Company #3391 or any caustic-base (low sudsing, non-perfumed, easily rinsed) detergent solution which provides a minimum 2% sodium hydroxide. The solution should be prepared in accordance with the manufacturer's instructions. Solution should be room temperature.
- Recommended sanitizer: A.C. Fergusson Company SuperChlor (1 ounce in 5 gallons of water) or any sanitizer which provides a minimum of 200 parts per million of available chlorine. Solution should be room temperature.

- Three five (5) gallon figals (syrup tanks) and fittings, cleaned and sanitized (one for water; one for cleaner; one for sanitizer)
- Containers for cleaner and sanitizer solutions
- Clean, nonabrasive cloths
- Bucket
- Small brush
- Extra nozzles
- Extra jumpers

CLEANING PROCEDURES

1. Disconnect each syrup container from its product line. Fill a figal with clean water, pressurize to 40 to 60 psig and connect the pressurized figal to the syrup product line. Remove syrup from the lines by activating the dispensing valve. Continuously activate the dispensing valve until all syrup has been purged from the product lines and valves as noted by the flow of clean water from the valves. All product lines should be sequentially purged of syrup using this procedure.
2. Clean all lines and fittings with cleaning solution and rinse with clean, room temperature water to remove all traces of residual product.
3. Clean each valve product line as follows: Fill a figal with dissolved cleaning solution, pressurize to 40 to 60 psig and connect the pressurized figal to the syrup product line. Activate the dispensing valve continuously for one (1) minute to remove all air bubbles. Pressurize the lines by pulsing the valves, 15 seconds ON, OFF, then immediately ON again for fifteen (15) cycles, then allow the valve to remain flowing for three (3) minutes. Repeat pulsing and flowing the valves again until all cleaning solution has been used.

WARNING: DO NOT allow cleaning and sanitizing solutions to remain in syrup systems longer than is necessary to complete these procedures. Exceeding contact time will result in damage to valve components.

4. Wait three (3) minutes and then flush the cleaning solution from the lines with clean water by connecting a pressurized figal with clean water. Pressurize and flush the valves by pulsing the valve for (15) cycles and then flushing three (3) minutes as described in the previous paragraph. Continue pulsing and flushing until testing with phenolphthalein shows the rinse water is free of residual detergent.
5. Sanitize each valve product line as follows: Be sure all connections are cleaned and sanitized before connecting to each product line. Fill a figal with dissolved sanitizing solution, pressurize to 40 to 60 psig and connect the pressurized figal to the syrup product line. Activate the dispensing valve continuously for one (1) minute to remove all air bubbles. Allow the sanitizing solution to flow through each valve while activating the valves for fifteen (15) cycles, then leave valves OFF and allow to stand pressurized for thirty (30) minutes. Activate the valves for fifteen (15) cycles, then flush remaining sanitizer continuously through the valves.
6. Remove the nozzles and the diffuser assemblies from the valves, disengage diffuser assembly components and clean with cleaning solution. Agitate the assemblies to assure assemblies are clean. Place them in a container of sanitizing solution for fifteen (15) minutes. Wearing sanitary gloves, remove the nozzles and diffuser assemblies from the sanitizing solution, drain dry, then reassemble them to the valves.
7. Reconnect the syrup containers to their respective circuits and ready the unit for operation.
8. Draw drinks to refill lines and flush the sanitizing solution from the dispenser. Taste the beverage to verify that there is no off-taste (chlorine).

WATER BATH CLEANING

It is recommended that the water bath be cleaned two to four times annually, depending upon local conditions and/or required by state and local health departments. The water bath should be clean to obtain maximum cooling efficiency.

WARNING: Melt ice bank completely, disconnect electrical power and the wiring harness quick disconnect on the refrigeration deck before draining the water bath and attempting to remove the refrigeration deck from the water bath or permanent damage to the deck or coil basket may result.

The water bath compartment is well insulated and it may take five or six hours for the ice to melt. Refilling with warm water may help to melt the ice more rapidly.

1. Remove plug from the drain tube (located under the drip tray) and position the tube to drain into the drain pan.
2. After the ice has melted, remove the deck.
3. Thoroughly clean around all the coils and between all crevasses with a brush and cleaning solution to remove all algae and foreign matter. Dry the water bath.
4. Clean the condenser with a vacuum cleaner or a soft bristle brush.
5. Clean compressor, agitator motor and fan assembly with a cloth, wiping off accumulated dust.
6. Place the refrigeration deck into its original position.
7. Replace drain tube plug and fill the water bath with clean cold water.
8. Reconnect the wire harness on the refrigeration deck.
9. Place cabinet top back onto the unit in its original position and secure.
10. Clean and sanitize product lines and valves per number 4 above before placing dispenser into service.

LIQUID LEVEL CONTROL WITH TIMER

PURPOSE OF L.L.C. WITH TIMER

The liquid level control with timer is designed to protect the pump of a carbonation system against running dry and consequent pump damage.

OPERATION

Designed to operate as a normal liquid level control under normal conditions. The timer circuit monitors the running time of the pump motor. If the pump motor runs continuously for the specified time period, the timer circuit will discontinue the operation of the pump motor until the reset switch is manually reset.

NOTE: The built-in carbonator normal refill time for the UCC-40 is 3 to 5 seconds (15 fl oz. [444 ml] normal refill volume).

Usually, when the water flow to the pump is interrupted for any extended period, the residual water present in the pump warms up and will eventually evaporate, but as it warms up it continues to lubricate the wear points of the pump. Experience has shown that a seven minute interruption in water flow is not significantly detrimental to the future operation of the pump.

WARNING: The L.L.C. with timer will give no protection against the initial startup of a new carbonator pump with no water being present at the pump. A new pump which has never pumped water is considered dry and will suffer damage in a matter of 2 to 3 minutes.

FEATURES

220v/50z and 115v/60z models are available.

3-minute and 7-minute models are available.

Designed to control and protect a 1/2hp maximum pump motor.

Reset

A. Challenger and Enterprise carbonator.

- Separate manual reset switch (#35-0181) ensures that the cause of the problem has been corrected before continued use of the pump motor. This feature has been provided in these carbonators since January 1, 1995.
- Carbonators built before January 1, 1995 can be fitted with the time style liquid level control and can be manually reset by disconnecting the power supply cord from the electrical supply and then reconnecting same.

B. Overcounter Dispensers with built-in Carbonators (models CTC-20, CTC-40)

- These models have a rocker switch which controls the power supply to the liquid level control (carbonation system). This switch is accessible through the top surface of the top cover of the CTC-40, and located on the top left corner of the front valve mounting plate of the model CTC-20. The timer can be reset by turning this rocker switch "off" and then "on" again.

WIRING DIAGRAM

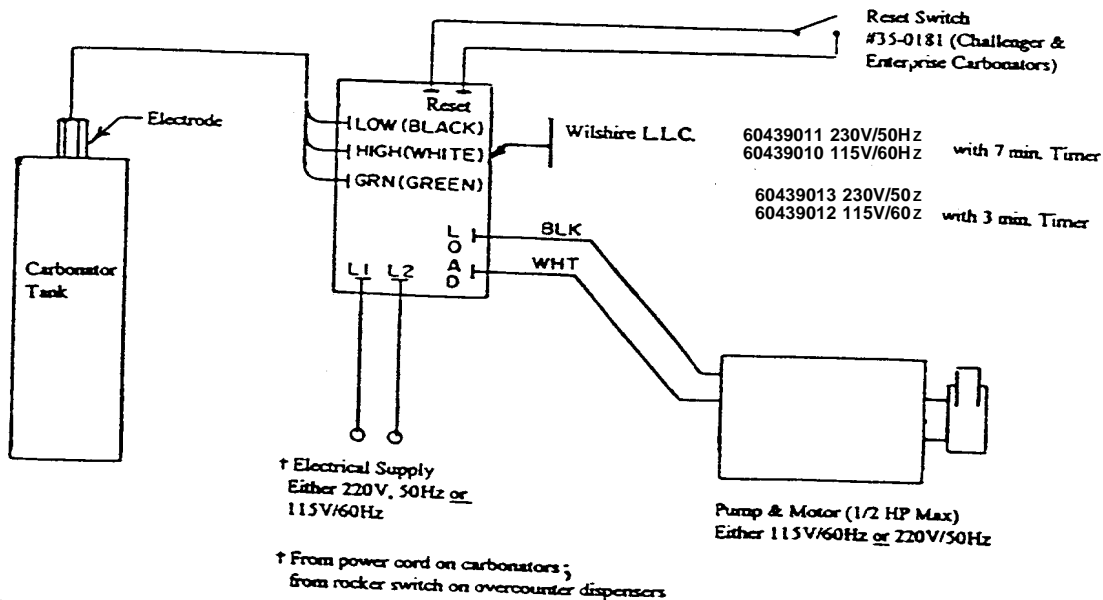

FLUIDS/GAS DIAGRAM

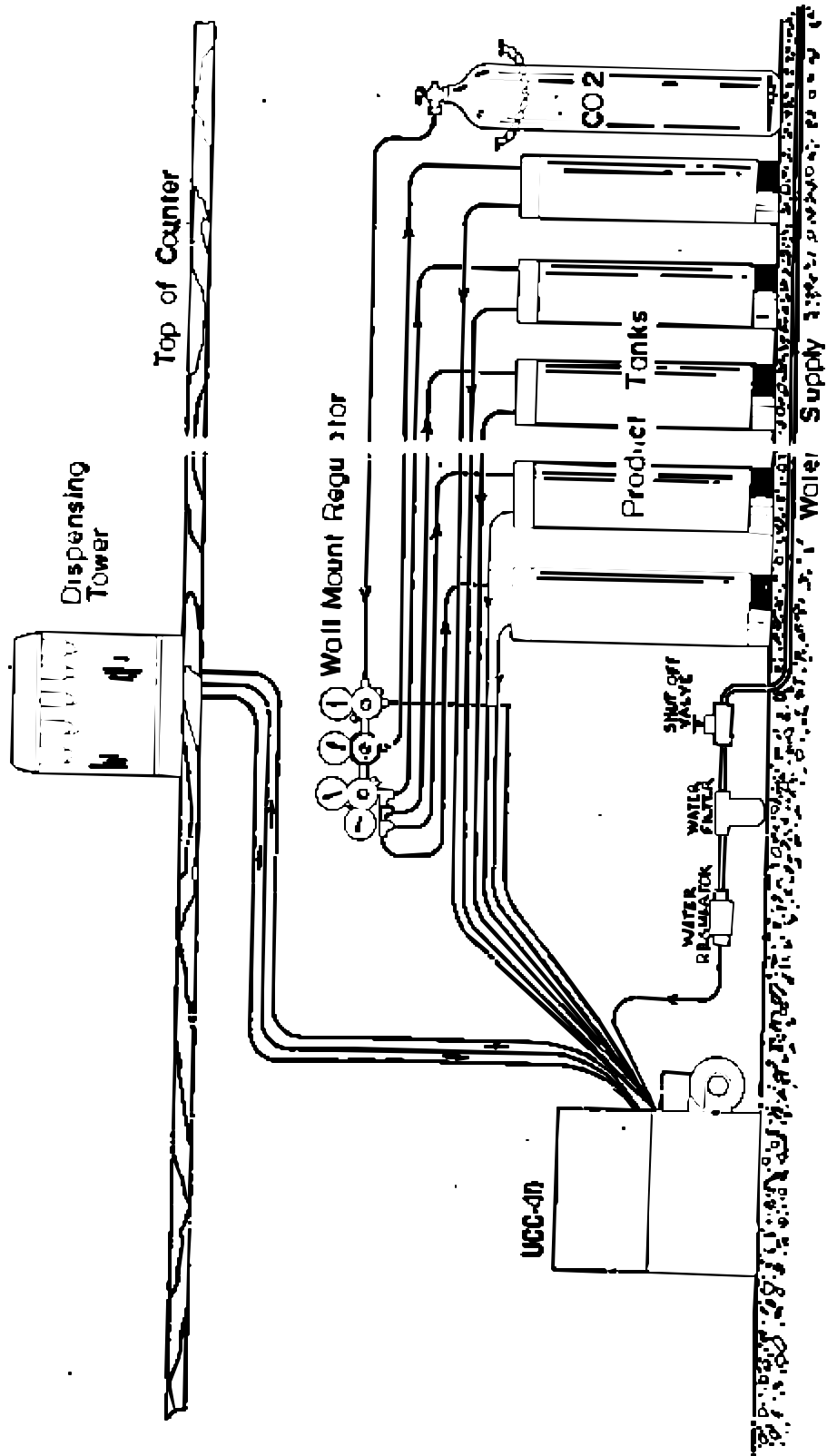

**UCC-40 WITH BUILT-IN CARBONATOR
FLUIDS/GAS DIAGRAM**

WIRING DIAGRAM

UCC-40 WIRING DIAGRAM

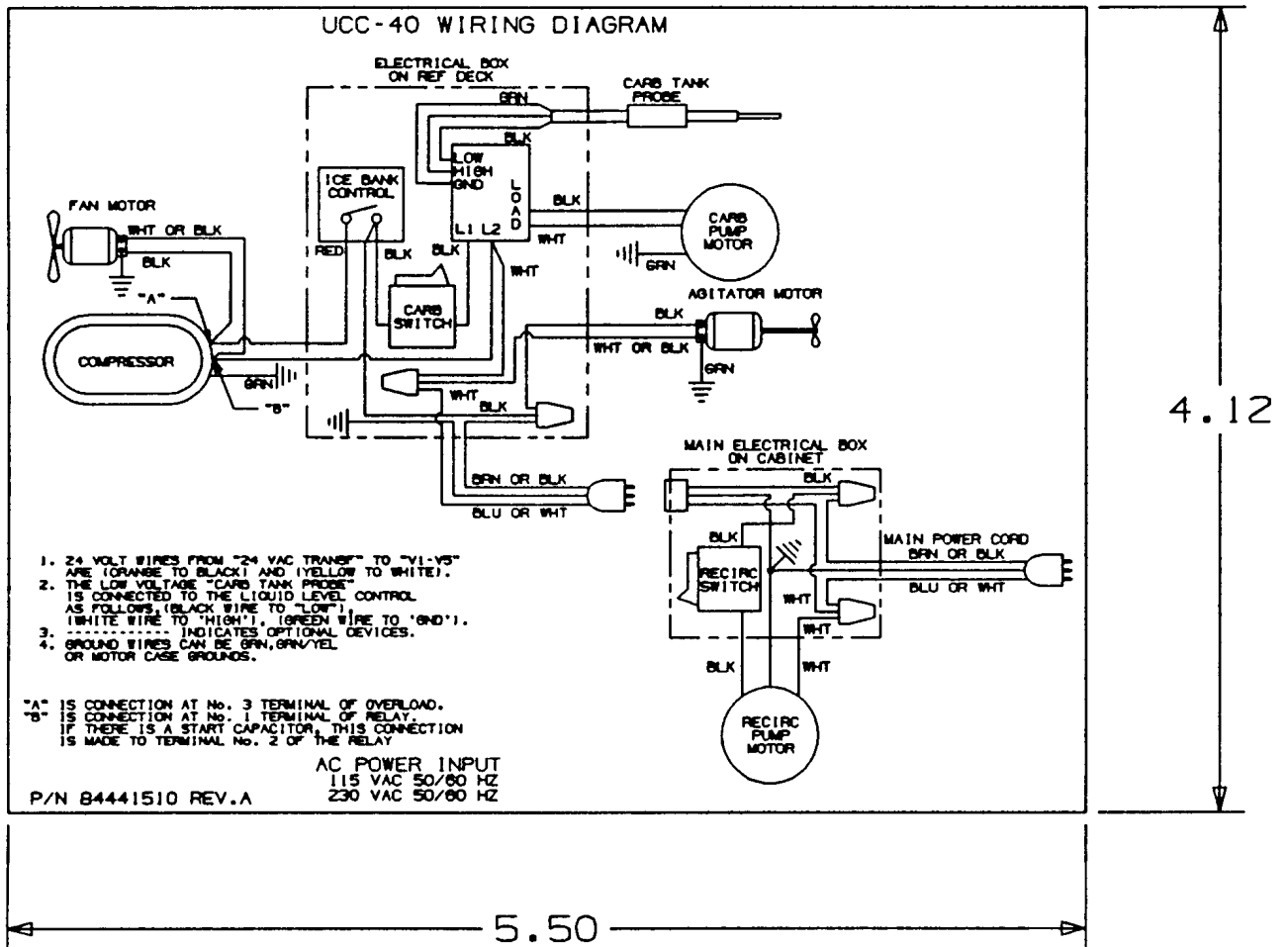

UCC-40 PARTS EXPLODED DIAGRAM

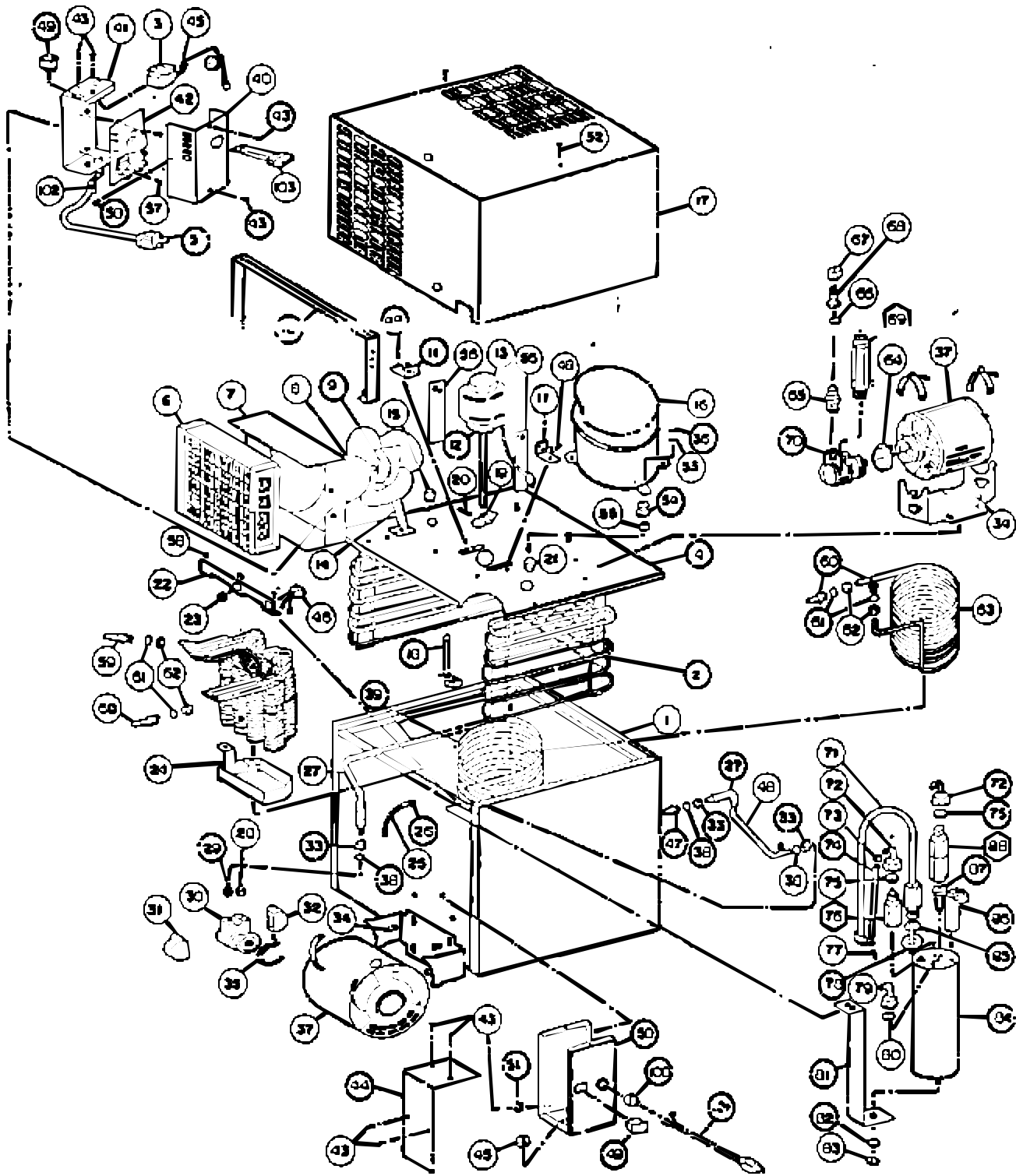



UCC-40 PARTS LIST

Item	New Part No	Description	Old Part No.	Torrington Part No.
1	26-0064	Cabinet Ass'y	119-178-007	
2	26-0146	Coil Ass'y - Freon	119-184-001	
3	55-0339	Control - Temperature	155-969-000	186074001
4	23-0218	Plate - Compressor (1/3 hp)	119-066-004	
5	35-0128	Power Cord (115v)	119-360-000	
	35-0124	Power Cord (220v)	115-558-000	
6	55-0087	Condenser	101-434-000	
7	23-0510	Shroud - Fan	115-194-000	
8	35-0015	Blade - Fan	105-240-000	
9	35-0094	Motor - Fan (115v)	119-646-000	
	35-0097	Motor - Fan (220v)	119-805-220	
10	23-0302	Handle	119-118-000	
11	23-0040	Bracket - Agitator Motor (2 Required)	115-659-000	
12	40-0411	Washer	106-141-000	
13	35-0078	Motor - Agitator 115v	119-447-009	
	35-0079	Motor - Agitator 220v	119-447-229	
14	23-0107	Bracket - Fan Motor	103-024-000	
15	55-0031	Bushing	103-067-000	
16a	26-0360	Compressor Ass'y 1/3hp 115v		
	35-0148	Relay 1/3 hp 115v	101-049-000	
	35-0104	Overload 1/3hp 115v	101-050-000	
16b	26-0366	Compressor Ass'y 1/3hp 220v/50hz		
	35-0151	Relay 1/3hp 220v/50hz	119-803-001	
	35-0106	Overload 1/3hp 220v/50hz	119-803-002	
16c	26-0362	Compressor Ass'y 1/3hp 220v/60hz		
	35-0152	Relay 1/3hp 220v/60hz	119-803-261	
	35-0107	Overload 1/3hp 220v/60 hz	119-803-262	
17	23-0419	Lid Gray	119-165-007	
18	26-0061	Bulb Holder (Temperature Control)	112-544-675	
	23-0064	Bracket - Bulb Holder	119-791-097	
19	26-0058	Blade - Agitator	115-790-001	
20	40-0252	Pin - Cotter S.S.	106-140-000	
21	40-0262	Plug - Cap	113-035-000	31699012
22	23-0130	Bracket - Line	119-185-707	
23	55-0033	Bushing	119-426-875	34065
24	23-0208	Basket - Product Coil	119-192-001	
25	65-0085	Tube - Vinyl	104-299-000	
26	40-0019	Clamp	108-111-000	48114005
27	65-0047	Tube - Insulation 3/8 I.D.	104-249-000	
28	40-0081	Connector S.S. 3/8 MPT x 3/8B	115-576-000	77081400
29	40-0243	Fitting - Compression 3/8 Tube x 3/8 MPT	119-688-002	
30	55-0275	Pump S.S. 50 GPH	107-776-000	
31	55-0215	Cover Insulation (Left)	115-396-000	
32	55-0214	Cover Insulation (Right)	115-395-000	
33	40-0249	Nut - Pack 3/8	119-689-000	
34	40-0297	Screw	110-861-902	718400297
35	35-0035	Clamp V c/w Bolt	100-361-000	20543
36	35-0115	Pin - Hitch	101-046-002	
37	35-0072	Motor 1/3hp 115v	115-442-000	60030058
	35-0075	Motor 1/3hp 220v 50/60hz	115-442-220	71860673
38	40-0208	O Ring	103-123-000	31525012
39	26-0136	Coil Assembly CO2 Water	119-993-728	
40	23-0231	Cover - Electrical Box	119-446-001	
41	23-0819	Wrapper Electrical Box 115v	119-465-006	
	23-0783	Wrapper Electrical Box 220v	119-465-001	
42	35-0062	Control - Liquid Level 115v	110-863-000	
	35-0065	Control - Liquid Level 220v 50/60hz	110-863-220	60439010
43	40-0288	Screw	103-462-000	



44	23-0230	Cover - Electrical Box (115 v only)	119-070-002	
45	55-0035	Bushing	119-446-000	
46	35-0137	Receptacle Single Outlet (115v only)	119-425-000	
47	40-0038	Fitting - Compression 3/8B x 3/8 Tube	119-688-000	60285002
48	26-0888	CO2 Water Return	119-993-729	
49	35-0182	Switch - Rocker	115-650-000	
50	23-0185	Box Electrical (115v only)	119-070-006	
51	40-0424	Washer - Cup	119-435-001	
52	40-0282	Screw	119-435-001	
53	40-0407	Washer	103-296-000	
54	35-0055	Grommet	101-162-001	60065064
55	35-0158	Sleeve	119-622-000	
56	23-0303	Heat Sink	105-139-000	
57	40-0284	Screw	102-649-000	
58	40-0294	Screw	108-120-000	
59	40-0241	Fitting Compression 1/4 Tube x 3/8 B	119-334-000	
60	40-0240	Fitting Compression	119-078-000	77030402
61	40-0204	O Ring	103-074-000	
62	40-0244	Nut - Pack 1/4	105-313-000	
63	26-0345	Coil Pre-Chill	119-865-002	
64	35-0035	Clamp V c/w Bolt	100-361-000	20543
65	40-0046	Connector Brass 3/8MPT x 3/8 F	115-109-375	
66	40-0418	Washer 3/8 Flare	115-354-000	48033002
67	40-0175	Nut - Swivel 3/8F	110-918-000	77030100
68	40-0153	Nipple - Swivel 1/4B	110-919-000	
69	26-0431	Filter Assembly	110-934-000	
70	55-0276	Pump - Brass 125 GPH	110-872-000	
71	26-0421	Electrode Assembly 19"	119-915-019	
72	40-0116	Elbow S.S. 1/4B X 1/4 Swivel Nut	112-708-000	77040100
73	40-0016	Clamp	105-039-000	48114003
74	65-0003	Tube - Braid	115-115-000	174478000
75	40-0409	Washer 1/4 Flare	104-053-000	30359
76	26-0038	Back Check Single	113-139-000	65259001
77	40-0065	Connector S.S. 1/4B X 1/4B	100-826-000	77040200
78	40-0412	Washer	110-861-004	
79	40-0120	Elbow S.S. 3/8B X 1/4 Swivel Nut	115-512-000	77040900
80	40-0418	Washer 3/8 Flare	115-534-000	4803002
81	23-0070	Bracket - Mounting Carb Tank	119-891-006	
82	40-0422	Washer - Lock S.S.	119-903-000	40734001
83	40-0188	Nut S.S. 1/4	119-464-001	
84	55-0073	Carb Tank Ass'y	119-862-007	
85	40-0216	O Ring	113-180-000	
86	26-0685	Valve - Pressure Relief	110-948-000	71860230
87	55-0040	Insert - Water Inlet .087	110-862-087	
88	26-0037	Back Check - Double Valve	110-947-000	
89	55-0198	Body - Filter Brass 3/8 NPT	110-924-00	
90	55-0197	Screen - Filter	103-948-000	
91	40-0206	O Ring	103-113-000	
92	40-0130	Fitting Inlet Brass 3/8 F	110-924-000	
93	40-0208	O Ring	103-123-000	31525012
94	55-0013	Spring - Back Check	115-050-000	
95	55-0012	Ball - S.S. Back Check	115-049-000	64560
96	55-0011	Seat Fitting - Back Check	115-048-000	
97	40-0207	O Ring	103-122-000	31525003
98	55-0010	Body - Single Back Check 1/4 Flare	115-046-000	
99	55-0016	Body - Double Back Check	115-449-000	

IMI Cornelius Inc.
www.cornelius.com