



IMI CORNELIUS INC ■ One Cornelius Place ■ Anoka, MN 55303-6234

Telephone (800) 238-3600

Facsimile (612) 422-3246

# Installation Manual

## VANTAGE

### PRE-MIX DISPENSER

#### **IMPORTANT:**

##### TO THE INSTALLER.

It is the responsibility of the Installer to ensure that the water supply to the dispensing equipment is provided with protection against backflow by an air gap as defined in ANSI/ASME A112.1.2-1979; or an approved vacuum breaker or other such method as proved effective by test.

Water pipe connections and fixtures directly connected to a potable water supply shall be sized, installed, and maintained according to Federal, State, and Local Codes.

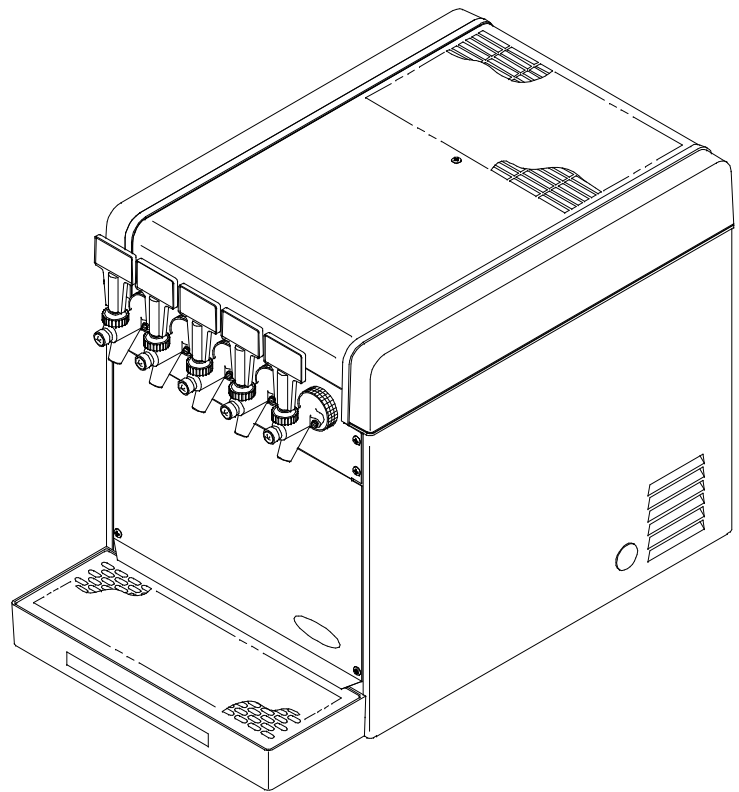

Part No. 560001790  
August 11, 1997  
Control Code A

#### THIS DOCUMENT CONTAINS IMPORTANT INFORMATION

This Manual must be read and understood before installing or operating this equipment

# TABLE OF CONTENTS

	Page
<b>SAFETY</b> .....	<b>1</b>
SAFETY INFORMATION .....	1
RECOGNIZE SAFETY INFORMATION .....	1
UNDERSTAND SIGNAL WORDS .....	1
FOLLOW SAFETY INSTRUCTIONS .....	1
<b>GENERAL INFORMATION</b> .....	<b>3</b>
GENERAL DESCRIPTION .....	3
UNIT DESCRIPTION .....	3
WARRANTY REFERENCE INFORMATION .....	3
THEORY OF OPERATION .....	5
<b>INSTALLATION</b> .....	<b>7</b>
UNPACKING AND INSPECTION .....	7
IDENTIFICATION OF LOOSE-SHIPED PARTS .....	7
SELECTING LOCATION .....	7
INSTALLATION .....	8
INSTALLING UNIT ON COUNTERTOP .....	8
FILL WATER TANK AND START REFRIGERATION SYSTEM .....	8
ROUTING AND CONNECTING PRODUCT INLET LINES .....	9
INSTALLING DISPENSING VALVES KNOBS .....	9
CONNECTING CO2 GAS LINES TO PRODUCT TANKS .....	9
PREPARING UNIT FOR OPERATION .....	10
UNIT OPERATION .....	10
<b>OPERATOR'S INSTRUCTIONS</b> .....	<b>11</b>
OPERATING CONTROLS .....	11
DISPENSING VALVE .....	11
DAILY PRE-OPERATION CHECK .....	11
UNIT OPERATION .....	11
ADJUSTMENTS .....	11
PRODUCT TANK CO2 REGULATORS .....	11
ADJUSTING DISPENSED PRODUCT FLOW RATE .....	11
REPLENISHING CO2 SUPPLY .....	12
REPLENISHING PRODUCT SUPPLY .....	12
CLEANING AND SANITIZING .....	12
DAILY CLEANING OF UNIT .....	12
SANITIZING UNIT .....	12
CHECKING DROP-IN REFRIGERATION ASSEMBLY CONDENSER COIL FOR RESTRICTIONS .....	12
CHECKING ICE WATER BATH .....	13
CLEANING CO2 GAS CHECK VALVES .....	13
<b>SERVICE AND MAINTENANCE</b> .....	<b>15</b>
PREPARING UNIT FOR SHIPPING OR RELOCATING .....	15
HOOD, FRONT ACCESS PANEL AND DRIP TRAY REMOVAL .....	15
HOOD REMOVAL .....	15

## TABLE OF CONTENTS (cont'd)

	<b>Page</b>
FRONT ACCESS PANEL REMOVAL .....	15
DRIP TRAY REMOVAL .....	17
PERIODIC INSPECTION .....	17
ADJUSTMENTS .....	17
ADJUSTING PRODUCT TANKS CO2 REGULATORS .....	17
ADJUSTING DISPENSED PRODUCT FLOW RATE .....	17
CLEANING AND SANITIZING .....	17
DAILY CLEANING OF UNIT EXTERIOR .....	17
WEEKLY CLEANING OF DISPENSING VALVES .....	18
SANITIZING UNIT .....	18
CLEANING DROP-IN REFRIGERATION ASSEMBLY CONDENSER COIL ....	20
CHECKING ICE WATER BATH .....	20
CLEANING WATER TANK .....	20
REPLENISHING CO2 SUPPLY .....	21
REPLENISHING PRODUCT SUPPLY .....	22
PRODUCT FLAVOR CHANGE .....	22
CLEANING CO2 SYSTEM CO2 GAS CHECK VALVES .....	22
<b>TROUBLESHOOTING .....</b>	<b>25</b>
TROUBLESHOOTING DISPENSING SYSTEM .....	25
NO PRODUCT DISPENSED. ....	25
DISPENSED PRODUCT COMES OUT OF DISPENS- ING VALVE CLEAR BUT FOAMS IN CUP. ....	25
DISPENSED PRODUCT FOAMS AS IT LEAVES DISPENSING VALVE. ...	25
TROUBLESHOOTING REFRIGERATION SYSTEM .....	26
COMPRESSOR DOES NOT OPERATE. ....	26
COMPRESSOR OPERATES CONTINUOUSLY BUT DOES NOT FORM SUFFICIENT ICE BANK. ....	26
CONDENSER FAN MOTOR NOT OPERATING. ....	26
AGITATOR MOTOR NOT OPERATING. ....	26
<b>WARRANTY .....</b>	<b>28</b>

### LIST OF FIGURES

FIGURE 1. VANTAGE FIVE-FLAVOR PRE-MIX DISPENSER SHOWN .....	3
FIGURE 2. FLOW DIAGRAM (FIVE-FLAVOR UNIT SHOWN) .....	6
FIGURE 3. UNIT PRODUCT INLET CONNECTIONS .....	9
FIGURE 4. PARTS IDENTIFICATION (FIVE-FLAVOR UNIT SHOWN) .....	16
FIGURE 5. DISPENSING VALVE PARTS IDENTIFICATION .....	19
FIGURE 6. CO2 GAS CHECK VALVE .....	22
FIGURE 7. WIRING DIAGRAM .....	23

### LIST OF TABLES

TABLE 1. DESIGN DATA .....	4
TABLE 2. LOOSE-SHIPED PARTS .....	7

# SAFETY

## SAFETY INFORMATION

### Recognize Safety Information

This is the safety-alert symbol. When you see this symbol on our machine or in this manual, be alert to the potential for personal injury.

Follow recommended precautions and safe operating practices.



### Understand Signal Words

A signal word - *DANGER*, *WARNING*, OR *CAUTION* is used with the safety-alert symbol. *DANGER* identifies the most serious hazards.

Safety signs with signal word *DANGER* or *WARNING* are typically near specific hazards.

General precautions are listed on *CAUTION* safety signs. *CAUTION* also calls attention to safety messages in this manual.



### Follow Safety Instructions

Carefully read all safety messages in this manual and on your machine safety signs. Keep safety signs in good condition. Replace missing or damaged safety signs. Learn how to operate the machine and how to use the controls properly. Do not let anyone operate the machine without instructions. Keep your machine in proper working condition. Unauthorized modifications to the machine may impair function and/or safety and affect the machine life.

**Claims:** In the event of shortage, notify the carrier as well as IMI Cornelius immediately. In the event of damage, notify the carrier. **IMI Cornelius is not responsible for damage occurring in transit, but will gladly render assistance necessary to pursue your claim. Merchandise must be inspected for concealed damage within 15 days of receipt.**

<b>Warranty Registration Date</b> (to be filled out by customer)
<b>Unit Part Number:</b>
<b>Serial Number:</b>
<b>Install Date:</b>
<b>Local Authorized Service Center:</b>

THIS PAGE LEFT BLANK INTENTIONALLY

# GENERAL INFORMATION

**IMPORTANT: To the user of this manual** - This manual is a guide for installing, operating, and maintaining this equipment. Refer to Table of Contents for page location of detailed information pertaining to questions that arise during installation, operation, service and maintenance, or troubleshooting this equipment.

This Unit contains no User serviceable parts and must be installed and serviced by a qualified Service Person.

## GENERAL DESCRIPTION

This section gives the Unit description, theory of operation, and design data for the four and five-flavor Vantage Pre-Mix Dispensers hereafter referred to as Units.

## UNIT DESCRIPTION

The Units are compact with stainless-steel lower housings. The Units may be island-mounted or installed on front or rear countertop. These Units are equipped with drop-in type 1/3 H.P. refrigeration assemblies and are removable for service and maintenance.

Installation of Unit on countertop, installation of LOOSE-SHIPPED PARTS, filling water tank with water, connection of Unit to product tanks with regulated CO<sub>2</sub> pressure, and connection of Unit to electrical outlet with proper electrical requirements is all that is required to set Unit up for operation.



**CAUTION: Before shipping, storing, or relocating this Unit, the product systems *must* be sanitized and all sanitizing solution *must* be purged from the product systems with potable water. A freezing ambient environment will cause residual water remaining inside the Unit to freeze resulting in damage to the internal components.**

## WARRANTY REFERENCE INFORMATION

<b>Warranty Registration Date (to be filled out by customer)</b>
<b>Unit Part Number:</b>
<b>Serial Number:</b>
<b>Install Date:</b>
<b>Local Authorized Service Center:</b>

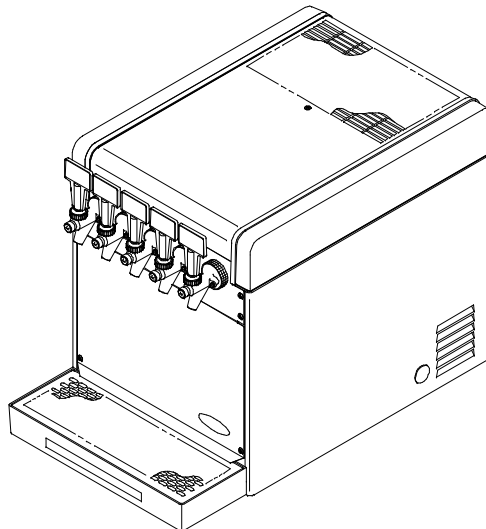

**FIGURE 1. VANTAGE FIVE-FLAVOR PRE-MIX DISPENSER SHOWN**

**Table 1. Design Data**

<b>Table 1. Design Data</b>	
<b>Unit Part Numbers:</b>	
<b>60 Hz Units</b>	
Four-Flavor 120 VAC, 60 Hz	281604XXX
Five-Flavor 120 VAC, 60 Hz	281605XXX
Four-Flavor 230 VAC, 60 Hz	481604XXX
Five-Flavor 230 VAC, 60 Hz	481605XXX
<b>50 Hz Units (CE Units)</b>	
Four-Flavor 230 VAC, 50 Hz	481704XXX
Five-Flavor 230 VAC, 50 Hz	481705XXX
<b>Overall Dimensions:</b>	
Width	15-inches
Height	18-1/2 inches
Depth (with drip tray in place on Unit)	26-inches
<b>Weight (approximate):</b>	
Shipping (one carton)	90 pounds
Dry Weight (approximate)	88 pounds
Ice Bank Weight (approximate)	12 pounds
Drop-In Refrigeration Assembly	48 pounds
Water Bath Capacity (no ice bank)	5.75 gallons

Dispensing Rate: (approximate)

No. of Valves	No. of 6-oz. Drinks/Min	*No. of drinks 38° F or below (minimum)
4	4	100
5	4	100

\*Number of 6-oz. drinks dispensed 38° F or below @ 75° F product inlet temperature and 75° F ambient.

<b>Refrigeration Requirement:</b>	
Refrigerant	See Unit Nameplate
Ambient Operating Temperature	50° F to 105° F
<b>Electrical Requirements:</b>	
Operating Voltage	See Unit Nameplate
Current Draw	See Unit Nameplate

## THEORY OF OPERATION

(see Figure 2)

A CO<sub>2</sub> cylinder delivers carbon dioxide (CO<sub>2</sub>) gas through adjustable CO<sub>2</sub> regulators to the product tanks. When dispensing valve is opened, CO<sub>2</sub> pressure exerted upon product tank contents pushes product from the product tank, through the Unit cooling coil, and on to the dispensing valve resulting in a dispensed drink.

When Unit power cord is plugged into an electrical outlet, the compressor, condenser fan motor, and agitator motor will start and begin forming an ice bank in the water tank. When full ice bank has been formed, compressor and condenser fan motor will stop but agitator motor will continue to operate circulating ice water in water tank. The water tank ice bank control will cycle compressor and condenser fan motor on and off as required to maintain a full ice bank.



**WARNING: CO<sub>2</sub> displaces oxygen. Strict attention *must* be observed in the prevention of CO<sub>2</sub> (carbon dioxide) gas leaks in the entire CO<sub>2</sub> and soft drink system. If a CO<sub>2</sub> gas leak is suspected, particularly in a small area, *immediately* ventilate the contaminated area before attempting to repair the leak. Personnel exposed to high concentration of CO<sub>2</sub> gas will experience tremors which are followed rapidly by loss of consciousness and suffocation.**



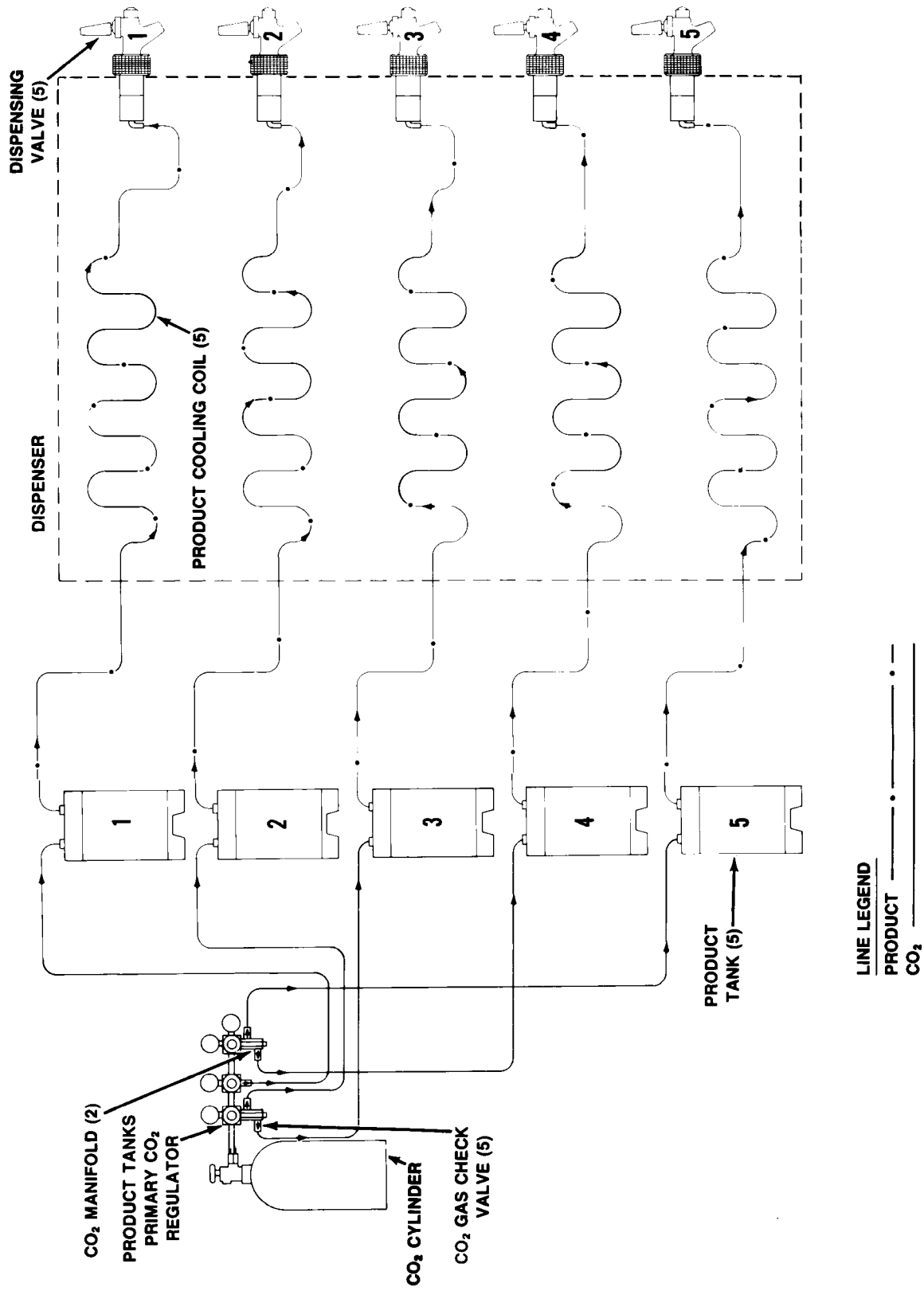

FIGURE 2. FLOW DIAGRAM (FIVE-FLAVOR UNIT SHOWN)

# INSTALLATION

This section covers unpacking and inspection, identification of LOOSE-SHIPPED PARTS, selecting location, installing Unit, preparing Unit for operation, and Unit operation.

## UNPACKING AND INSPECTION

(see Figure 4)

**NOTE: The Unit was thoroughly inspected before leaving the factory and the carrier has accepted and signed for it. Any damage or irregularities should be noted at time of delivery (or not later than 15 days from date of delivery) and immediately reported to the delivering carrier. Request a written inspection report from Claims Inspector to substantiate any necessary claim. File claim with the delivering carrier, not with IMI Cornelius Inc.**

1. After Unit has been unpacked, remove shipping tape and other packing material.
2. Remove hood by loosening screw on top of hood until screw disengages from drop-in refrigeration assembly, then lift hood up off Unit.
3. Unpack LOOSE-SHIPPED PARTS. Make sure all items are present and in good condition.

Item No.	Part No.	Name	Qty.	
			4-fl	5-fl
1	4537	Drip Tray	1	1
2	4547	Cup Rest	1	1
3	317904XXX	Flavor Decal Kit	1	1
4	151741039	Knob, Dispensing Valve	4	5

## IDENTIFICATION OF LOOSE-SHIPPED PARTS

(see Figure 4)

1. DRIP TRAY (item 1) to be installed on the Unit, then CUP REST (item 2) to be installed in the drip tray.
2. Individual flavor decals included in the FLAVOR DECAL KIT (item 3) are to be installed on the DISPENSING VALVES KNOBS (item 4), then knobs are to be installed on the dispensing valves .

## SELECTING LOCATION



**DANGER: To avoid possible fatal electrical shock or serious injury to the operator, it is highly recommended that a GFCI (ground fault circuit interrupt) be installed in the electrical circuit for the domestic Units. It is required that an ELCB (earth leakage circuit breaker) be installed in the electrical circuit for the export Units**

This Unit may be island-mounted or installed on a front or rear counter. Locate the Unit so the following requirements are satisfied.

1. The Unit *must* be installed near a properly grounded electrical outlet with proper electrical requirements. The electrical circuit should be fused at 20-amps (“slow-blow”) or circuit *must* be connected through an equivalent HACR circuit breaker. The electrical outlet *must* be accessible for ease of connecting and disconnecting the Unit power cord from the outlet. No other electrical equipment should be connected to this circuit. **ALL ELECTRICAL WIRING MUST CONFORM TO NATIONAL AND LOCAL ELECTRICAL CODES.**



**CAUTION: Do not place or store anything on top of the Unit.**

2. Locate the Unit to provide the following clearances—A minimum of 18-inches clearance *must* be maintained above the Unit to the nearest obstruction (shelf, cupboard, ceiling, etc.). A minimum clearance of 12-inches must be maintained on the back side and 6-inches clearance on both sides of the Unit to allow for proper air flow through the Unit. The Unit must be located close to a permanent drain if a drip tray drain hose will be connected to the drip tray.

## INSTALLATION

### INSTALLING UNIT ON COUNTERTOP

The product inlet supply lines, Unit power cord, water tank drain hose, and drip tray drain hose (if used) may be either routed through hole cut in the countertop under the Unit or over back edge of the countertop behind the Unit. Proceed as follows to install the Unit.

1. Place Unit in position on the countertop.
2. To comply with National Sanitation Foundation (NSF) requirements, Unit base must be sealed to the countertop and all access holes to inside of the Unit base must be closed and sealed.

**NOTE: An alternate arrangement to avoid sealing Unit base to countertop as described would be to install the optional Leg Kit (4923).**

- A. Tilt Unit up to expose bottom of base.
- B. Liberally apply a silastic sealant such as Dow Corning RTV 731 or equivalent on base bottom edges.

**NOTE: Do not move Unit after positioning or seal from Unit base to countertop will be broken.**

- C. Lower Unit into operating position on countertop to complete seal from Unit base to countertop.
- D. Apply additional sealant around bottom of Unit base. Seal must have a minimum radius of 1/2-inch to prevent crevices and to insure a complete seal.

### FILL WATER TANK AND START REFRIGERATION SYSTEM

(see Figure 4)

**NOTE: Use low-mineral-content water where a local water problem exists.**

1. Remove the Unit front access panel, then make sure plug in water tank drain hose located behind the panel is securely in place.
2. Lift insulation pad covering front section of the water tank.
3. Fill water tank with clean water until water runs out of the water tank overflow tube which will empty into the drip tray. *USE LOW-MINERAL-CONTENT WATER WHERE A LOCAL WATER PROBLEM EXISTS.*
4. Replace insulation pad over front section of the water tank.



**WARNING: The Unit must be electrically grounded to avoid possible fatal electrical shock or serious injury to the operator. The Unit power cord is equipped with a three-prong plug. If a three-hole (grounded) electrical outlet is not available, use an approved method to ground the Unit.**

5. Plug Unit power cord into a properly grounded electrical outlet. The refrigeration system will start after a 2-second time delay.

## ROUTING AND CONNECTING PRODUCT INLET LINES

(see Figures 2, 3, and 4)

1. Route product inlet lines (numbered for identification) up over edge of the countertop behind the Unit or up through hole cut in the countertop underneath the Unit. Route product inlet lines up to a point behind the Unit front access panel close to the barbed product inlet connections on the Unit.

**NOTE: The Unit barbed product inlet lines connections to the dispensing valves are labeled to identify the dispensing valve they serve. For example: the line labeled "1" must be connected to system that provides product to be dispensed from NO.1 dispensing valve. (NO. 1 dispensing valve is the valve on right side when facing front of Unit.)**

**IMPORTANT**

**TO THE INSTALLER: DO NOT CUT CLAMPS SECURING BARBED FITTINGS ON ENDS OF THE UNIT PRODUCT INLET CONNECTIONS.**

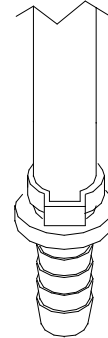

**FIGURE 3. UNIT PRODUCT INLET CONNECTIONS**

2. Connect product inlet lines to the barbed product inlet connections on the Unit. Secure connections with tubing clamps.
3. All access holes to inside of the Unit base must be closed and sealed.

## INSTALLING DISPENSING VALVES KNOBS

(see Figure 4)

1. Install dispensing valves knobs (LOOSE-SHIPPED with the Unit) on the dispensing valves.

## CONNECTING CO<sub>2</sub> GAS LINES TO PRODUCT TANKS

(see Figure 2)



**WARNING: CO<sub>2</sub> displaces oxygen. Strict attention *must* be observed in the prevention of CO<sub>2</sub> (carbon dioxide) gas leaks in the entire CO<sub>2</sub> and soft drink system. If a CO<sub>2</sub> gas leak is suspected, particularly in a small area, *immediately* ventilate the contaminated area before attempting to repair the leak. Personnel exposed to high concentration of CO<sub>2</sub> gas will experience tremors which are followed rapidly by loss of consciousness and suffocation.**



**WARNING: To avoid personal injury and/or property damage, always secure CO<sub>2</sub> cylinder in upright position with a safety chain to prevent it from falling over. Should valve become accidentally damaged or broken off, CO<sub>2</sub> cylinder can cause serious personal injury.**

1. Position CO<sub>2</sub> cylinder in upright position and secure with safety chain.

2. Install primary CO<sub>2</sub> regulator on CO<sub>2</sub> cylinder. *MAKE SURE NYLON WASHER IS INSIDE REGULATOR ASSEMBLY COUPLING NUT BEFORE CONNECTING TO CYLINDER.*
3. Connect CO<sub>2</sub> lines, with quick disconnects on their ends (not provided), to primary CO<sub>2</sub> regulator assembly. *DO NOT CONNECT CO<sub>2</sub> LINES TO PRODUCT TANKS AT THIS TIME.*

## PREPARING UNIT FOR OPERATION



**CAUTION:** Before opening CO<sub>2</sub> cylinder shutoff valve, turn primary CO<sub>2</sub> regulators adjusting screws to the left (counterclockwise) until all tension is relieved from adjusting screws springs.

1. Open (counterclockwise) CO<sub>2</sub> cylinder shutoff valve slightly to allow lines to slowly fill with gas, then open valve fully to back-seat valve. (Back-seating valve prevents leakage around valve shaft.)
2. Adjust product tanks primary CO<sub>2</sub> regulators pressure settings as instructed in SERVICE AND MAINTENANCE section of this manual..
3. Connect CO<sub>2</sub> and product lines to product tanks. Check for leaks and tighten loose connections.

## UNIT OPERATION

1. Dispense from each dispensing valve until air is purged from systems and product is dispensed.
2. Check for leaks and tighten loose connections.
3. Adjust dispensing valves for dispensed product flow rate as instructed in SERVICE AND MAINTENANCE section of this manual.
4. Install Unit front access panel and secure with screws.
5. Install hood on Unit and secure with screw. *MAKE SURE HOOD GRILLE IS POSITIONED OVER THE REFRIGERATION CONDENSER COIL WHEN HOOD IS IN PLACE ON THE UNIT.*
6. Install drip tray on the Unit, then install cup rest in the drip tray.

# OPERATOR'S INSTRUCTIONS

This section covers operators instructions for operating controls, daily pre-operation check, adjustments, replenishing CO<sub>2</sub> and product supplies, cleaning and sanitizing, checking drop-in refrigeration assembly condenser coil for restrictions, and checking ice water bath.



**WARNING:** Disconnect electrical power to Unit to prevent personal injury before attempting any internal maintenance. Only qualified personnel should service internal components or electrical wiring.



**CAUTION:** Do not place or store anything on top of the Unit.

**IMPORTANT:** Only qualified personnel should service the internal components or electrical wiring.

## OPERATING CONTROLS

(see Figure 4)

### DISPENSING VALVE

Place cup under dispensing valve nozzle. Pull dispensing valve knob forward until cup is full, of product then release knob.

## DAILY PRE-OPERATION CHECK

7. Make sure primary CO<sub>2</sub> regulator assembly 1800-psi gage indicator is not in shaded ("change CO<sub>2</sub> cylinder") portion of dial. If so, CO<sub>2</sub> cylinder is almost empty and must be replaced as instructed in SERVICE AND MAINTENANCE section of this manual.
8. Sufficient product supply in all product tanks. If not, replenish product supply as instructed in SERVICE AND MAINTENANCE section of this manual.
9. Make sure drip tray is clean and clean cup rest is in place in drip tray.

## UNIT OPERATION

Place cup or glass under dispensing valve. Pull dispensing valve knob forward until cup or glass is full of product, then release the knob.

## ADJUSTMENTS

### PRODUCT TANK CO<sub>2</sub> REGULATORS

Product tank CO<sub>2</sub> regulators should be periodically checked for proper pressure settings and if necessary, adjusted as instructed in SERVICE AND MAINTENANCE section of this manual.

### ADJUSTING DISPENSED PRODUCT FLOW RATE

Product flow rate of dispensed product should be periodically checked and if necessary, adjusted as instructed in SERVICE AND MAINTENANCE section of this manual.

## REPLENISHING CO<sub>2</sub> SUPPLY



**WARNING:** CO<sub>2</sub> displaces oxygen. Strict attention *must* be observed in the prevention of CO<sub>2</sub> (carbon dioxide) gas leaks in the entire CO<sub>2</sub> and soft drink system. If a CO<sub>2</sub> gas leak is suspected, particularly in a small area, *immediately* ventilate the contaminated area before attempting to repair the leak. Personnel exposed to high concentration of CO<sub>2</sub> gas will experience tremors which are followed rapidly by loss of consciousness and suffocation.

**NOTE:** When indicator on primary CO<sub>2</sub> cylinder regulator assembly 1800-psi gage is in shaded (“change CO<sub>2</sub> cylinder”) portion of the dial, CO<sub>2</sub> cylinder is almost empty and should be changed.

CO<sub>2</sub> supply should be checked daily and if necessary, replenished as instructed in SERVICE AND MAINTENANCE section of this manual.

## REPLENISHING PRODUCT SUPPLY

Product supply should be checked daily and if necessary, replenished as instructed in SERVICE AND MAINTENANCE section of this manual.

## CLEANING AND SANITIZING

### DAILY CLEANING OF Unit

Daily cleaning of Unit should be performed at end of daily operation as instructed in SERVICE AND MAINTENANCE section of this manual.

### SANITIZING UNIT

The product systems should be sanitized as instructed every 90-days as instructed in SERVICE AND MAINTENANCE section of this manual. The sanitizing procedure should be performed by a qualified Service Person.

## CHECKING DROP-IN REFRIGERATION ASSEMBLY CONDENSER COIL FOR RESTRICTIONS



**CAUTION:** The refrigeration assembly condenser coil must be cleaned every 30-days. Excessive accumulation of dust, lint, and grease on the condenser coil will restrict air flow through the coil and cause the refrigeration system to overheat. Operating the refrigeration system in an overheated condition will eventually lead to compressor failure and will automatically void the factory warranty.

**NOTE:** Circulating air required to cool condenser coil is drawn in through grille on top of the hood and is exhausted out through louvers on sides and back of the hood. Restricting air in and out of Unit will decrease its cooling efficiency.

Area on top of Unit hood must be kept free of obstructions at all times. *Make sure nothing is stored on top of hood.* Cooling Unit condenser coil should be periodically cleaned every 30-days as instructed in SERVICE AND MAINTENANCE section of this manual.

## **CHECKING ICE WATER BATH**

A “gurgle” heard from the Unit indicates water level in water tank is low and more water should be added as instructed for maximum product cooling. Refer to SERVICE AND MAINTENANCE section of this manual.

## **CLEANING CO<sub>2</sub> GAS CHECK VALVES**

(see Figure 2 and 6)

The CO<sub>2</sub> gas check valves *must* be inspected and serviced as instructed at least once a year under normal conditions and after any CO<sub>2</sub> system servicing or disruption. Servicing of gas check valves should be performed by qualified personnel. Refer to SERVICE AND MAINTENANCE section of this manual.





THIS PAGE LEFT BLANK INTENTIONALLY

# SERVICE AND MAINTENANCE

This section describes the service and maintenance procedures to be performed on the Unit.

**IMPORTANT:** Only qualified personnel should service the internal components or electrical wiring.



**DANGER:** To avoid possible fatal electrical shock or serious injury to the operator, it is *highly recommended* that a GFI (ground fault circuit interrupt) be installed in the electrical circuit for the 60 Hz Units. It *is required* that an ELCB (earth leakage circuit breaker) be installed in the electrical circuit for the 50 Hz Units.



**WARNING:** Disconnect electrical power from the Unit to prevent personal injury before attempting any internal maintenance. *Only* qualified personnel should service the internal components or electrical wiring.

## PREPARING UNIT FOR SHIPPING OR RELOCATING



**CAUTION:** The Unit is intended for indoor installation *only*. *Do not* install this Unit in an outdoor environment which would expose it to the outside elements.



**CAUTION:** Before shipping, storing, or relocating this Unit, the product systems *must* be sanitized and all sanitizing solution *must* be purged from the product systems. A freezing ambient environment will cause residual water remaining inside the Unit to freeze resulting in damage to internal components.

## HOOD, FRONT ACCESS PANEL AND DRIP TRAY REMOVAL

(see Figure 4)

### HOOD REMOVAL



**CAUTION:** *Do not* place or store anything on top of the Unit.

Remove screw securing hood, then lift hood straight up off the Unit. Make sure grille on top of the hood is positioned over the refrigeration condenser coil when re-installing the hood.

**IMPORTANT:** Circulating air, required to cool the refrigeration assembly condenser coil is drawn in through grille on top of the hood and is exhausted out through louvers on sides and back of the Unit.

### FRONT ACCESS PANEL REMOVAL

Remove two screws securing the front access panel, then remove the panel.

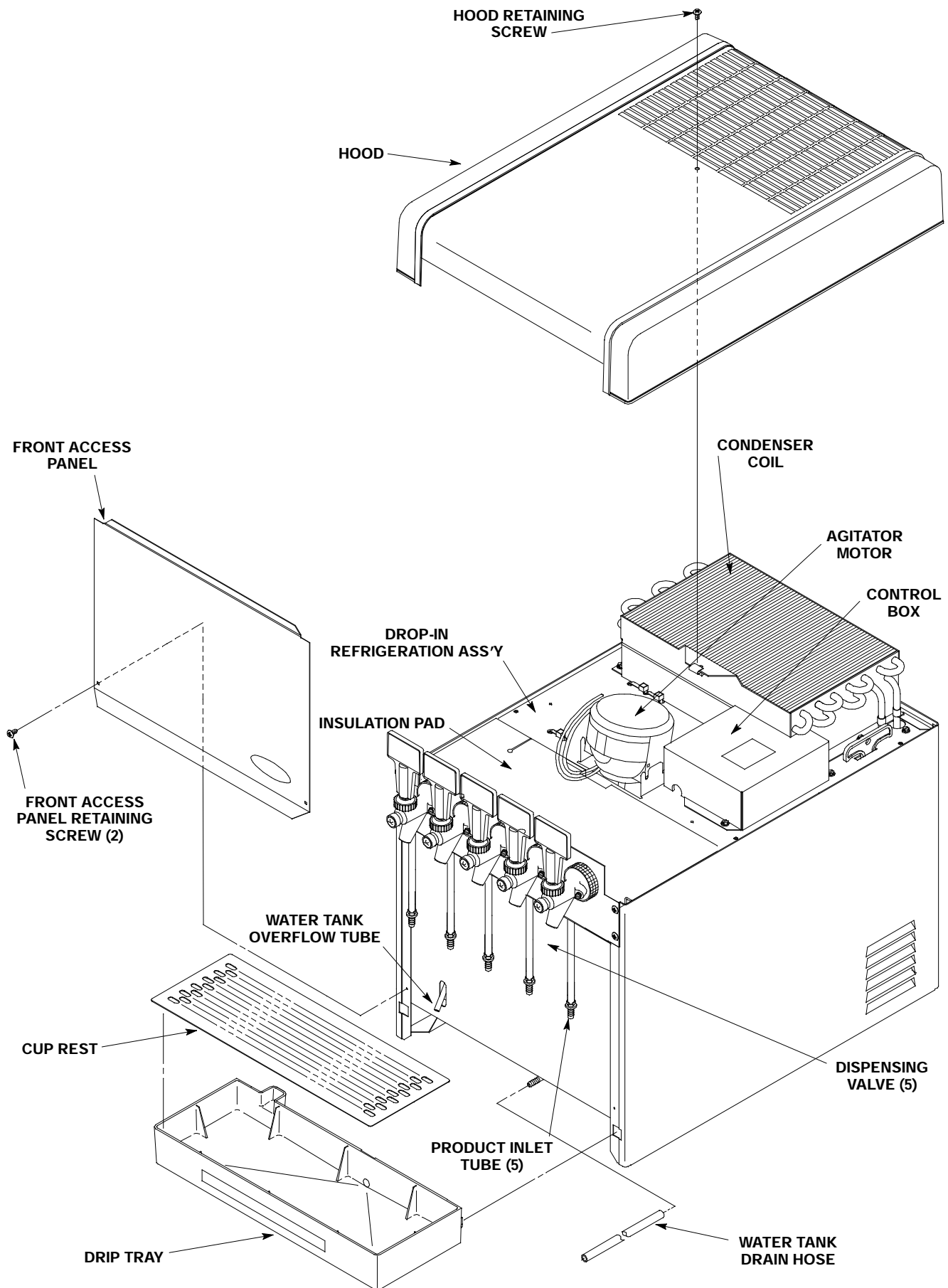

FIGURE 4. PARTS IDENTIFICATION (FIVE-FLAVOR UNIT SHOWN)

## DRIP TRAY REMOVAL



**CAUTION:** Use extreme care when removing and installing the drip tray to prevent breaking off plastic holding tabs on back of the tray.

Very carefully Lift drip tray up, then pull tray back to remove.

## PERIODIC INSPECTION

1. Clean the drop-in refrigeration assembly condenser coil every 30-days as instructed. Cleaning the condenser coil should be performed by a qualified Service Person. *DO NOT place objects on top of the hood or on back side of the Unit. Restricting circulating air in and out of the Unit will cause the refrigeration system to overheat.*
2. Check the dispensing valves for dripping that indicates leakage and repair as necessary.

## ADJUSTMENTS

### ADJUSTING PRODUCT TANKS CO<sub>2</sub> REGULATORS



**WARNING:** CO<sub>2</sub> displaces oxygen. Strict attention *must* be observed in the prevention of CO<sub>2</sub> (carbon dioxide) gas leaks in the entire CO<sub>2</sub> and soft drink system. If a CO<sub>2</sub> gas leak is suspected, particularly in a small area, *immediately* ventilate the contaminated area before attempting to repair the leak. Personnel exposed to high concentration of CO<sub>2</sub> gas will experience tremors which are followed rapidly by loss of consciousness and suffocation.

(see Figure 2)

Set product tanks CO<sub>2</sub> regulators, using Cornelius PRE-MIX COMPUTER slide rule or bottling room chart, at equilibrium pressure for highest temperature encountered between product tank storage area and Unit plus 5-psig operating pressure for lines 10-feet in length or less and no vertical lift. Add one pound for every 10-feet over initial 10-feet of product tank to Unit line length and one pound for every 2-feet of vertical lift. Add one pound for every product tank on line over three tanks.

### ADJUSTING DISPENSED PRODUCT FLOW RATE

(see Figure 5)

Rotate dispensing valve Compensator Adjusting Screw to the left (counterclockwise) for higher product flow rate or to the right (clockwise) for lower product flow rate.

## CLEANING AND SANITIZING

### DAILY CLEANING OF UNIT EXTERIOR

1. Remove cup rest and drip tray from the Unit.
2. Wash cup rest and drip tray, then rinse them with warm water.
3. Re-install cup rest and drip tray on the Unit.

4. Rinse out sponge with clean water, then wring excess water out of sponge and wipe off all external surfaces of Unit. Wipe Unit dry with a clean soft cloth. *DO NOT USE ABRASIVE TYPE CLEANERS.*

## WEEKLY CLEANING OF DISPENSING VALVES

(see Figure 5)

Dispensing valves should be cleaned at least weekly for proper operation. A convenient time to clean dispensing valves is at time unit is being sanitized. Perform following procedure to clean dispensing valves.

1. Remove quick disconnects (black) from product tanks outlets.
2. Open dispensing valves to relieve pressure on systems.
3. Remove dispensing valve knobs by pulling knobs up and off valves.
4. Using a spanner wrench, loosen and remove coupling nuts from dispensing valves, then remove valves from unit.
5. Remove phillips-head screw on end of dispensing valve, then remove outer sleeve, spring, and inner sleeve.
6. Loosen and remove knob lever bonnet securing lever in dispensing valve body, then remove lever.
7. Slide shaft and seat assembly out through rear of dispensing valve body.
8. Wash disassembled dispensing valve parts in warm potable water.
9. Assemble dispensing valve by reversing disassembly procedure steps 5 through 7 preceding.
10. Disassemble and clean remaining dispensing valve by performing steps 5 through 9 preceding.
11. Remove compensators from inside sleeve and coupling nut assemblies.
12. Wash compensators in warm potable water, then install compensators in sleeve and coupling nut assemblies.
13. Install dispensing valves on unit. Make sure coupling nuts are tight.
14. Install quick disconnects on product tanks outlets.
15. Open dispensing valves to bleed air from systems and until product flows from valves.

## SANITIZING UNIT

**NOTE: An alternate to the preferred sanitizing procedure outlined below would be to remove dispensing valves, then make necessary connections to circulate sanitizing solution through the product systems. After systems have been sanitized, dispensing valves may then be disassembled (see Figure 5) and cleaned before re-installing on Unit.**

**IMPORTANT: Only qualified personnel should perform sanitizing procedure.**

The product systems should be sanitized every 90-days following Sanitizer Manufacturer's recommendations. Use Chlor-Tergent (Oakite Products, Inc.) or equivalent sanitizer.

1. Remove quick disconnects from product tanks, then rinse quick disconnects in warm water.
2. Using clean empty product tank, prepare full tank of sanitizing solution by using 70° F to 100° F (max) plain water and .67 oz./gallon of sanitizer. This mixture will provide 200-ppm of chlorine.
3. Shake sanitizing solution tank to thoroughly mix solution, then connect tank into system to be sanitized.
4. Place waste container under applicable dispensing valve. Open dispensing valve to permit sanitizing solution to purge product out of system and valve. Continue to draw from dispensing valve until only sanitizing solution is dispensed, then close valve.

- Repeat steps 3 and 4 preceding to purge product from and install sanitizing solution in remaining systems.



**CAUTION: Do not allow sanitizing solution to remain in systems longer than recommended contact time. Exceeding contact time will result in damage to stainless steel components.**

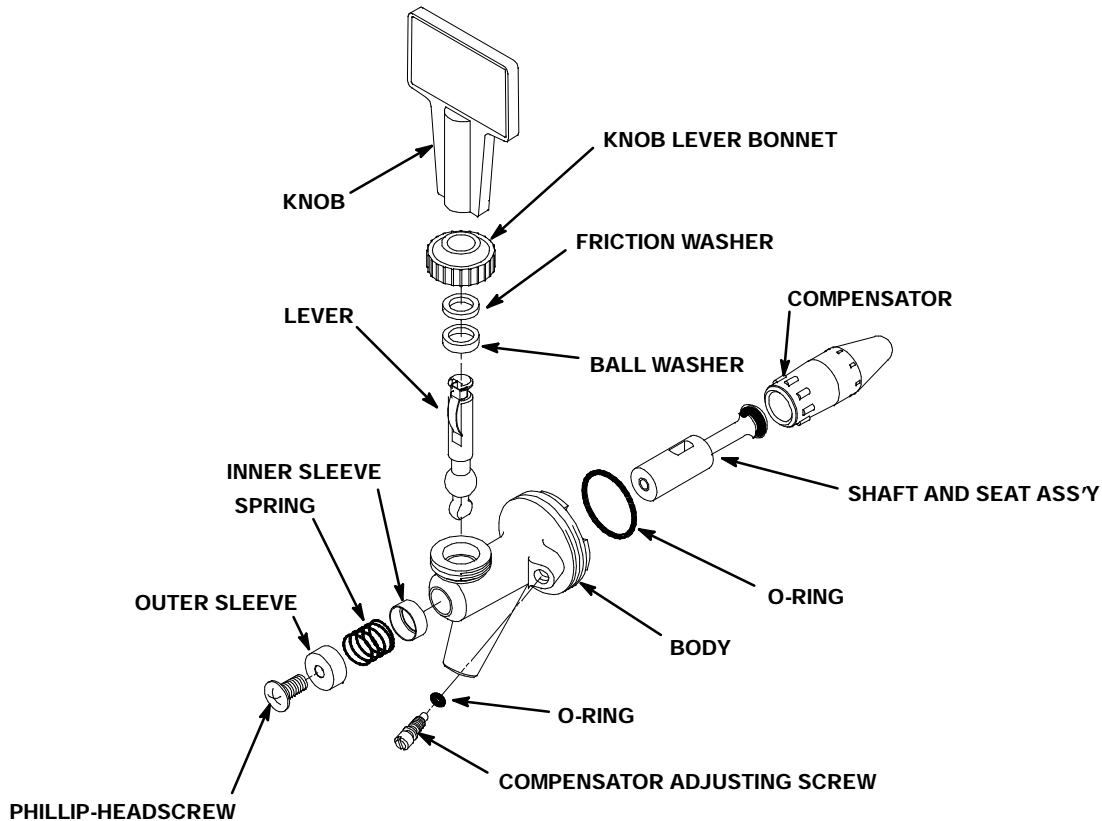

**FIGURE 5. DISPENSING VALVE PARTS IDENTIFICATION**

- Allow sanitizing solution to remain in systems for not less than 10 or no more than 15 minutes (max) contact time.
- Remove tank containing sanitizing solution from system, then connect tanks containing product into systems.



**WARNING: Flush sanitizing solution from systems as instructed. Residual sanitizing solution left in systems could create a health hazard.**

- Place waste container under dispensing valve. Open dispensing valve to permit product to purge sanitizing solution from system and dispensing valve. Continue to draw from valve until only product is dispensed from system, then close valve.
- Repeat step 8 to purge sanitizing solution out of remaining systems and until only product is dispensed.



**WARNING: To avoid possible personal injury or property damage, do not attempt to remove product tank cover until CO<sub>2</sub> pressure has been released from tank.**

- Thoroughly rinse inside and outside of product tank that was used for sanitizing solution to remove all solution residue.
- Clean exterior of Unit as instructed in DAILY CLEANING OF UNIT.

## CLEANING DROP-IN REFRIGERATION ASSEMBLY CONDENSER COIL

(see Figure 4)



**CAUTION:** The refrigeration assembly condenser coil must be cleaned every 30-days. Excessive accumulation of dust, lint, and grease on the condenser coil will restrict air flow through the coil and cause the refrigeration system to overheat. Operating the refrigeration system in an overheated condition will eventually lead to compressor failure and will automatically void the factory warranty.

Clean the drop-in refrigeration assembly coil as follows:

1. Unplug Unit power cord from the electrical outlet.
2. Remove screw securing the hood, then lift the hood straight up to remove.
3. Vacuum or use a soft brush to clean the condenser coil. If available, use low-pressure compressed air.
4. Clean dust and dirt from around top of the drop-in refrigeration assembly.
5. Install hood on the Unit and secure with screw.
6. Plug Unit power cord into electrical outlet. The refrigeration system will start after a 2-minute time delay.

## CHECKING ICE WATER BATH

(see Figure 4)

A “gurgle” heard from the Unit indicates water level in the water tank is low and more water should be added for maximum cooling. Before adding more water, check the ice water bath for cleanliness and check the water tank coils for excessive mineral deposit build-up.

1. Unplug Unit power cord from electrical outlet.
2. Remove screw securing the hood, then lift the hood straight up to remove.
3. Lift insulation pad covering front section of the water tank for visual inspection of the ice water bath and the ice bank.
4. Using a flashlight, inspect the ice water bath and ice bank for cleanliness. The ice water bath should be clear and the ice bank should be free of foreign particles.
5. If cleaning of the water tank is necessary, refer to CLEANING WATER TANK in this section.
6. Fill the water tank with clean water until water begins to run out of the overflow tube into the drip tray. *USE LOW-MINERAL-CONTENT WATER WHERE A LOCAL WATER PROBLEM EXISTS.*
7. Lower the insulation pad into proper position on top of the water tank.
8. Install Unit hood and secure with screw.
9. Plug Unit power cord into electrical outlet. The refrigeration system will start after a 2-minute time delay.

## CLEANING WATER TANK

(see Figure 4)

1. Unplug the Unit power cord from electrical outlet.
2. Remove two screws securing the Unit front access panel, then remove the panel.
3. Extend the water tank drain hose (located on front of Unit) to a waste container or floor drain. Remove plug from end of the drain hose and allow the water tank to drain.



4. Remove screw securing the hood, then lift the hood straight up to remove from the Unit.



**CAUTION:** The ice bank around the drop-in refrigeration assembly evaporator coils *must be completely melted* before attempting to lift the drop-in refrigeration assembly up and out of the Unit lower cabinet assembly. Attempting to lift the drop-in refrigeration assembly and ice bank together up out of the Unit lower housing assembly may cause damage to the evaporator coils.



**CAUTION:** Never use an ice pick or other instrument to remove ice from the drop-in refrigeration assembly evaporator coils. Such practice can result in a punctured refrigeration circuit.

5. Allow the ice bank around the drop-in refrigeration assembly evaporator coils to completely melt. Hot water may be used to speed up the melting process.
6. Remove four screws securing the drop-in refrigeration assembly in the Unit lower housing assembly.
7. *Very carefully*, lift the drop-in refrigeration assembly up and out of the Unit lower housing assembly.
8. Use a fiber brush and carefully clean mineral deposit build-up from the agitator motor shaft and the ice bank sensor.
9. Wash inside of the water tank and the drop-in refrigeration assembly evaporator coils, then rinse with clean water.
10. Install plug in end of the water tank drain hose.
11. *Very carefully*, install drop-in refrigeration assembly in Unit lower housing assembly by reversing the removal procedure.
12. Fill the water tank with clean water until water runs out of the water tank overflow hose. *USE LOW-MINERAL-CONTENT WATER WHERE A LOCAL WATER PROBLEM EXISTS.*
13. Plug Unit power cord into electrical outlet. The refrigeration system will start after a 2-minute time delay.
14. Install Unit hood and secure with screw.
15. Install Unit front access panel and secure with two screws.

## REPLENISHING CO<sub>2</sub> SUPPLY



**WARNING:** CO<sub>2</sub> displaces oxygen. Strict attention *must* be observed in the prevention of CO<sub>2</sub> (carbon dioxide) gas leaks in the entire CO<sub>2</sub> and soft drink system. If a CO<sub>2</sub> gas leak is suspected, particularly in a small area, *immediately* ventilate the contaminated area before attempting to repair the leak. Personnel exposed to high concentration of CO<sub>2</sub> gas will experience tremors which are followed rapidly by loss of consciousness and suffocation.

**NOTE:** When indicator on CO<sub>2</sub> cylinder primary CO<sub>2</sub> regulator assembly 1800-psi gage is in shaded ("change CO<sub>2</sub> cylinder") portion of dial, CO<sub>2</sub> cylinder is almost empty and should be changed.

1. Fully close (clockwise) CO<sub>2</sub> cylinder valve.
2. Slowly loosen primary CO<sub>2</sub> regulator assembly coupling nut allowing CO<sub>2</sub> pressure to escape, then remove regulator assembly from empty CO<sub>2</sub> cylinder.
3. Unfasten safety chain and remove empty CO<sub>2</sub> cylinder.



**WARNING:** To avoid personal injury and/or property damage, always secure CO<sub>2</sub> cylinder in upright position with safety chain to prevent it from falling over. Should valve become

4. Position CO<sub>2</sub> cylinder and secure with safety chain.
5. Make sure gasket is in place inside primary CO<sub>2</sub> regulator coupling nut, then install regulator on CO<sub>2</sub> cylinder.
6. Open (counterclockwise) CO<sub>2</sub> cylinder valve slightly to allow lines to slowly fill with gas, then open valve fully to back-seat valve. (Back-seating valve prevents leakage around valve shaft).

## REPLENISHING PRODUCT SUPPLY

**NOTE: The following instructions are applicable only when replenishing with the same flavor product. Refer to PRODUCT FLAVOR CHANGE when changing product flavor.**

1. Disconnect empty product tank from product system.
2. Check product tank quick disconnects for sticky or restricted operation. Wash disconnects in warm water.
3. Connect full tank of product into syrup system.

## PRODUCT FLAVOR CHANGE

1. Perform sanitizing procedure on product system product flavor change will be made on.
2. Check product tank quick disconnects for sticky or restricted operation. Wash disconnects in warm water.
3. Connect full tank of new flavor product into product system.

## CLEANING CO<sub>2</sub> SYSTEM CO<sub>2</sub> GAS CHECK VALVES

(see Figures 2 and 6 )

The CO<sub>2</sub> regulators and CO<sub>2</sub> manifold CO<sub>2</sub> gas check valves must be inspected and serviced at least once a year under normal conditions and after any servicing or disruption of the CO<sub>2</sub> system. **ALWAYS REPLACE BALL SEAT (QUAD RING SEAL) EACH TIME GAS CHECK VALVES ARE SERVICED.**

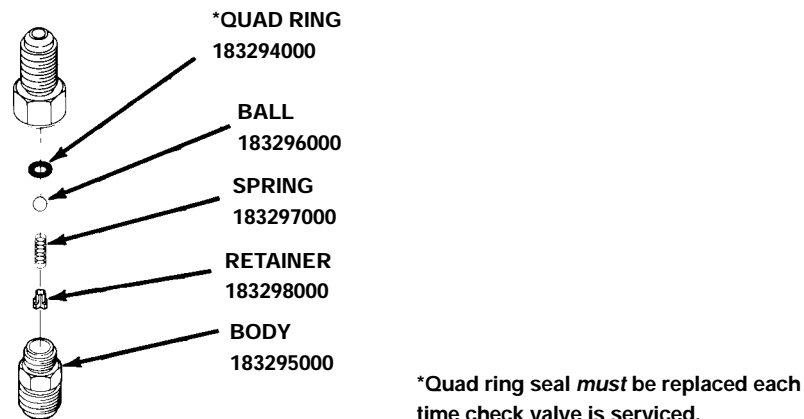
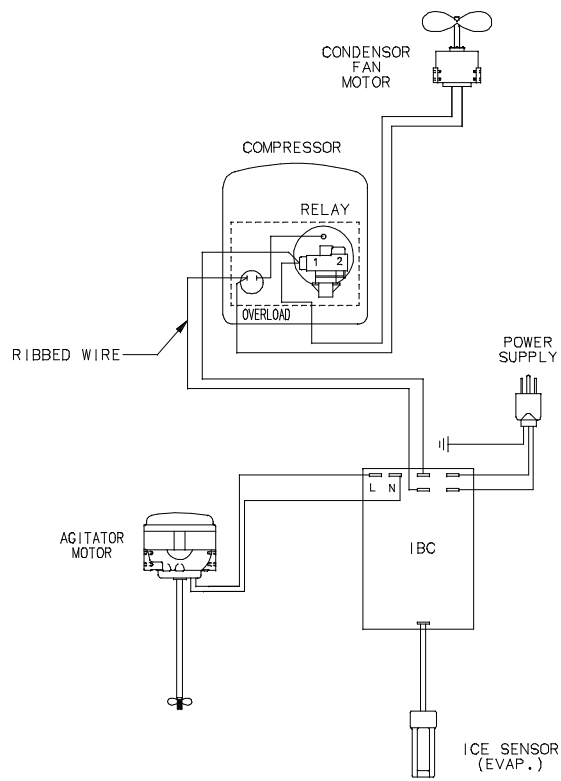

FIGURE 6. CO<sub>2</sub> GAS CHECK VALVE



**FIGURE 7. WIRING DIAGRAM**



THIS PAGE LEFT BLANK INTENTIONALLY

# TROUBLESHOOTING

**IMPORTANT:** Only qualified personnel should service internal components or electrical wiring.



**WARNING:** If repairs are to be made to a product system, remove quick disconnects from the applicable product tank, then relieve the system pressure before proceeding. If repairs are to be made to the CO<sub>2</sub> system, stop dispensing, shut off the CO<sub>2</sub> supply, then relieve the system pressure before proceeding. If repairs are to be made to the refrigeration system, make sure electrical power is disconnected from the unit.

Trouble	Probable Cause	Remedy
<b>TROUBLESHOOTING DISPENSING SYSTEM</b>		
NO PRODUCT DISPENSED.	A. Product tank quick disconnects not connected.	A. Connect quick disconnects.
	B. No product supply (tank empty).	B. Replenish product supply as instructed.
	C. No CO <sub>2</sub> supply.	C. Replenish CO <sub>2</sub> supply as instructed.
DISPENSED PRODUCT COMES OUT OF DISPENSING VALVE CLEAR BUT FOAMS IN CUP.	A. Oil film or soap scum in cups.	A. Use clean cups.
	B. Ice used for finished drink is sub-cooled.	B. Do not use ice directly from freezer. Allow ice to become "wet" before using. (Refer to following NOTE)
<b>NOTE: Crushed ice also causes dispensing problems. When finished drink hits sharp edges of ice, carbonation is released from dispensed drink.</b>		
DISPENSED PRODUCT FOAMS AS IT LEAVES DISPENSING VALVE.	A. Recovery rate of dispenser exceeded, ice bank depleted.	A. Allow ice bank to recover.
	B. Product tanks CO <sub>2</sub> regulator adjusted too high.	B. Adjust product tanks CO <sub>2</sub> regulator pressure as instructed.
	C. Dispensing valve restricted or dirty.	C. Sanitize system.
	D. Tapered gasket inside tube swivel nut connection distorted from being overtightened restricting product flow.	D. Replace tapered gasket. Make sure gasket is properly seated.
	E. Oil, water, or dirt in CO <sub>2</sub> supply.	E. Remove contaminated CO <sub>2</sub> . Clean CO <sub>2</sub> system (lines, regulators, etc.). Install a clean CO <sub>2</sub> supply.

Trouble	Probable Cause	Remedy
<b>TROUBLESHOOTING REFRIGERATION SYSTEM</b>		
COMPRESSOR DOES NOT OPERATE.	A. Ice bank sufficient.	A. Refrigeration not called for.
	B. Unit power cord unplugged.	B. Plug in Unit power cord.
	C. No power source (blown fuse) or tripped circuit breaker.	C. Replace fuse or reset circuit breaker. (Note: Fuse is not part of Unit)
	D. Low voltage.	D. Correct low voltage condition.
	E. Loose, disconnected, or broken wiring.	E. Tighten connections or replace broken wiring.
	F. Overload protector cut out; over-heated compressor. Condenser fan motor not operating as required.	F. Compressor will cool enough to restart. Do not overdraw cooling capacity of dispenser. Refer to "CONDENSER FAN MOTOR NOT OPERATING" in this section.
	G. Inoperative overload protector or start relay.	G. Replace inoperative part.
	H. Inoperative ice bank control.	H. Replace ice bank control.
	I. Inoperative compressor.	I. Replace compressor.
COMPRESSOR OPERATES CONTINUOUSLY BUT DOES NOT FORM SUFFICIENT ICE BANK.	A. Cooling capacity is exceeded by over-drawing.	A. Reduce amount of drinks drawn per given time.
	B. Unit located in excessively hot area or air circulation through condenser coil is restricted.	B. Relocate Unit or clean condenser coil as instructed.
	C. Refrigeration system leak.	C. Call refrigeration repairman.
<b>NOTE: Ice bank freezes from bottom of evaporator upward. A refrigerant leak or insufficient charge might show ice bank at bottom and not at top of evaporator.</b>		
<b>NOTE: If overload protector cuts out compressor, condenser fan motor will continue to run; otherwise; troubleshooting condenser fan motor problems is same as for "COMPRESSOR DOES NOT OPERATE" paragraph plus the following:</b>		
CONDENSER FAN MOTOR NOT OPERATING.	A. Jumper cord loose or disconnected from motor or terminal block. Broken wire in cord.	A. Tighten connections or replace cord.
	B. Fan blade obstructed.	B. Remove obstruction.
	C. Inoperative condenser fan motor.	C. Replace condenser fan motor.
AGITATOR MOTOR NOT OPERATING.	A. Unit power cord unplugged.	A. Plug in Unit power cord.
	B. No power source (blown fuse) or tripped circuit breaker.	B. Replace fuse or reset circuit breaker. (Note: Fuse is not part of Unit)
	C. Agitator motor propeller obstructed.	C. Remove obstructions.

Trouble	Probable Cause	Remedy
AGITATOR MOTOR NOT OPERATING (Cont'd)	D. Low voltage.	D. Correct low voltage condition.
	E. Loose, disconnected, or broken wiring.	E. Tighten connections or replace broken wiring.
	F. Inoperative agitator motor.	F. Replace agitator motor.



# WARRANTY

IMI Cornelius Inc. warrants that all equipment and parts are free from defects in material and workmanship under normal use and service. For a copy of the warranty applicable to your Cornelius, Remcor or Wilshire product, in your country, please write, fax or telephone the IMI Cornelius office nearest you. Please provide the equipment model number, serial number and the date of purchase.

## IMI Cornelius Offices

AUSTRALIA • P.O. 210, • RIVERWOOD, • NSW 2210, AUSTRALIA • (61) 2 533 3122 • FAX (61) 2 534 2166  
AUSTRIA • AM LANGEN FELDE 32 • A-1222 • VIENNA, AUSTRIA • (43) 1 233 520 • FAX (43) 1-2335-2930  
BELGIUM • BOSKAPELLEI 122 • B-2930 BRAASCHAAT, BELGIUM • (32) 3 664 0552 • FAX (32) 3 665 2307  
BRAZIL • RUA ITAOCARA 97 • TOMAS COELHO • RIO DE JANEIRO, BRAZIL • (55) 21 591 7150 • FAX (55) 21 593 1829  
ENGLAND • TYTHING ROAD ALCESTER • WARWICKSHIRE, B49 6 EU, ENGLAND • (44) 789 763 101 • FAX (44) 789 763 644  
FRANCE • 71 ROUTE DE ST. DENIS • F-95170 DEUIL LA BARRE • PARIS, FRANCE • (33) 1 34 28 6200 • FAX (33) 1 34 28 6201  
GERMANY • CARL LEVERKUS STRASSE 15 • D-4018 LANGENFELD, GERMANY • (49) 2173 7930 • FAX (49) 2173 77 438  
GREECE • 488 MESSOGION AVENUE • AGIA PARASKEVI • 153 42 • ATHENS, GREECE • (30) 1 600 1073 • FAX (30) 1 601 2491  
HONG KONG • 1104 TAIKOTSUI CENTRE • 11-15 KOK CHEUNG ST • TAIKOKTSUE, HONG KONG • (852) 789 9882 • FAX (852) 391 6222  
ITALY • VIA PELLIZZARI 11 • I-20059 • VIMARCATI, ITALY • (39) 39 608 0817 • FAX (39) 39 608 0814  
NEW ZEALAND • 20 LANSFORD CRES. • P.O. BOX 19-044 AVONDALE • AUCKLAND 7, NEW ZEALAND • (64) 9 8200 357 • FAX (64) 9 8200 361  
SINGAPORE • 16 TUAS STREET • SINGAPORE 2263 • (65) 862 5542 • FAX (65) 862 5604  
SPAIN • POLIGONO INDUSTRIAL • RIERA DEL FONOLLAR • E-08830 SANT BOI DE LLOBREGAT • BARCELONA, SPAIN • (34) 3 640 2839 • FAX (34) 3 654 3379  
USA • ONE CORNELIUS PLACE • ANOKA, MINNESOTA • (612) 421-6120 • FAX (612) 422-3255

LD004  
4/21/98

THIS PAGE LEFT BLANK INTENTIONALLY

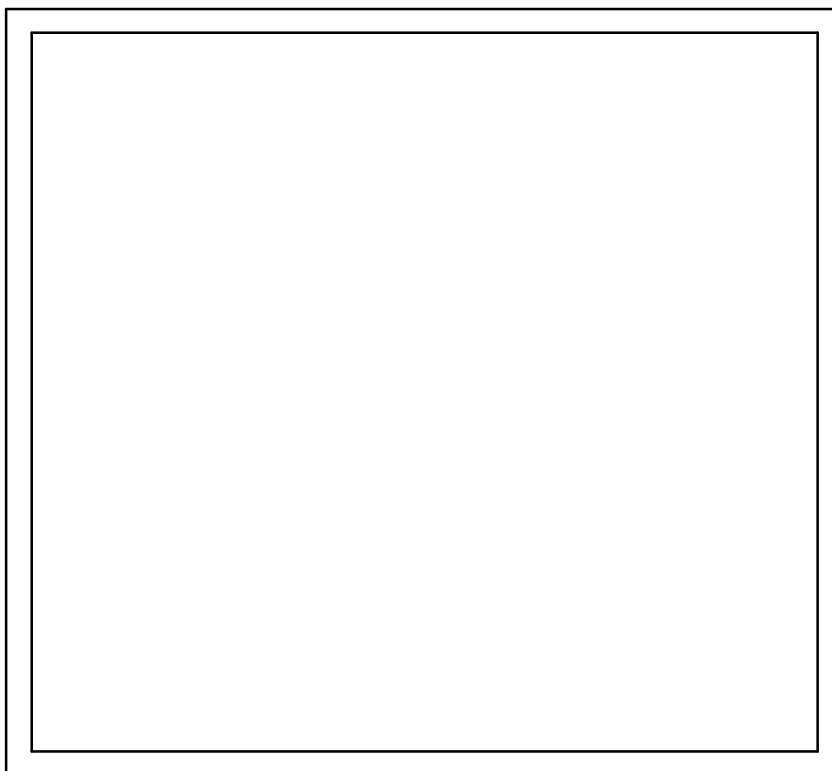

**IMI CORNELIUS INC.**

---

**CORPORATE HEADQUARTERS:**

**One Cornelius Place  
Anoka, Minnesota 55303-6234  
(612) 421-6120  
(800) 238-3600**

