

F13 Series

Service and Installation Manual

Please read this manual completely before attempting to install or operate this equipment!
Notify carrier of damage! Inspect all components immediately. See page 2.



Ice Cream Cabinets



CAUTION

**IMPORTANT INFORMATION
READ BEFORE USE
PLEASE SAVE THESE INSTRUCTIONS!**

Effective December 2006

Enodis[®]

CONTENTS SERIAL NUMBER LOCATION

SPECIFICATIONS..... 2
 RECEIVING & INSPECTING 3
 INSTALLATION 3
 OPERATION 4
 MAINTENANCE 4
 PRESSURE SETTINGS..... 4
 WIRING DIAGRAMS..... 5
 REFRIGERANT CHARGES & REPLACEMENT PARTS..... 6 & 7
 STANDARD LABOR GUIDELINES..... 8
 WARRANTIES..... 9 & 10

The serial number on self-contained units is located behind the louver near the compressor. The serial number on remote units is located in the mechanical area on the right side.

Always have the serial number of your unit available when calling for parts or service.

©2006 The Delfield Company. All rights reserved. Reproduction without written permission is prohibited. "Delfield" is a registered trademark of The Delfield Company.

SPECIFICATIONS

MODEL NUMBER	GALLON CAPACITY	NUMBER OF COVERS	H.P.	VOLTS/HERTZ PHASE	AMPS	BTU DESIGN LOAD	BTU SYS. CAP.	REF CHARGE OZ.	SHIP WEIGHT
Self-Contained Low Temp, Ice Cream Cabinet									
F13WC32	12	2	1/3	115/60/1	8.0	322	818	24	311 lbs/141 kg
F13WC44	24	4	1/3	115/60/1	8.0	506	983	24	380 lbs/173 kg
F13WC56	36	6	1/3	115/60/1	8.0	638	1073	24	408 lbs/185 kg
F13WC68	48	8	1/3	115/60/1	8.0	796	1160	24	475 lbs/216 kg

5-15P NEMA plug used on all lengths

MODEL NUMBER	GALLON CAPACITY	NUMBER OF COVERS	H.P.	VOLTS/HERTZ PHASE	AMPS	BTU DESIGN LOAD	EVAP. CAP. BTU/°TD	SHIP WEIGHT
Remote Low Temp, Ice Cream Cabinet								
F13WR24	12	2	N/A	115/60/1	1.5	322	27/29	195 lbs/89 kg
F13WR36	24	4	N/A	115/60/1	1.5	506	38/26	255 lbs/116 kg
F13WR48	36	6	N/A	115/60/1	1.5	638	46/23	295 lbs/134 kg
F13WR60	48	8	N/A	115/60/1	1.5	796	56/21	345 lbs/157 kg

*Recommended horsepower

MODEL NUMBER	GALLON CAPACITY	NUMBER OF COVERS	H.P.	VOLTS/HERTZ PHASE	AMPS	BTU DESIGN LOAD FRZR./RAIL	BTU SYS. CAP. FRZR./RAIL	REF CHARGE OZ.	SHIP WEIGHT
Self-Contained Low Temp, Ice Cream Cabinet With Syrup Rail									
F13BC44	24	4	1/3	115/60/1	8.0	506/192	983/828	24	435 lbs/197 kg
F13BC56	36	6	1/3	115/60/1	8.0	638/250	1073/979	24	480 lbs/218 kg
F13BC72	48	8	1/2	115/60/1	10.0	796/307	1309/1174	40	540 lbs/245 kg

5-15P NEMA plug used on all lengths

MODEL NUMBER	GALLON CAPACITY	NUMBER OF COVERS	H.P.	VOLTS/HERTZ PHASE	AMPS	BTU DESIGN LOAD FRZR./RAIL	BTU SYS. CAP. FRZR./RAIL	SHIP WEIGHT
Remote Low Temp, Ice Cream Cabinet With Syrup Rail								
F13BR36	24	4	N/A	115/60/1	1.5	506/192	38/11	285 lbs/129 kg
F13BR48	36	6	N/A	115/60/1	1.5	638/250	46/14	340 lbs/154 kg
F13BR60	48	8	N/A	115/60/1	1.5	796/307	56/17	400 lbs/182 kg



RECEIVING AND INSPECTING THE EQUIPMENT

Even though most equipment is shipped crated, care should be taken during unloading so the equipment is not damaged while being moved into the building.

1. Visually inspect the exterior of the package and skid or container. Any damage should be noted and reported to the delivering carrier immediately.
2. If damaged, open and inspect the contents with the carrier.
3. In the event that the exterior is not damaged, yet upon opening, there is concealed damage to the equipment notify the carrier. Notification should be made verbally as well as in written form.
4. Request an inspection by the shipping company of the damaged equipment. This should be done within 10 days from receipt of the equipment.
5. Check the lower portion of the unit to be sure legs or casters are not bent.
6. Also open the machine compartment housing and visually inspect the refrigeration package. Be sure lines are secure and base is still intact.
7. Freight carriers can supply the necessary damage forms upon request.
8. Retain all crating material until an inspection has been made or waived.

Uncrating the Equipment

First cut and remove the banding from around the crate. Remove the front of the crate material, use of some tools will be required. If the unit is on legs remove the top of the crate as well and lift the unit off the skid. If the unit is on casters it can be "rolled" off the skid.

INSTALLATION

Location

These units are for indoor use only. Be sure the location chosen has a floor strong enough to support the total weight of the cabinet and contents. Reinforce the floor if necessary to provide for maximum loading.

For the most efficient refrigeration, be sure to provide good air circulation inside and out.

Outside cabinet: Be sure that the unit has access to ample air. It is suggested that the rear of the unit be no less than two inches from any wall, partition or any other object which will restrict exhaust air flow. Avoid hot corners and locations near stoves and ovens.

Leveling

A level cabinet looks better and will perform better because the cabinet will not be subject to undue strain.

Self-contained models are provided with an **ON/OFF** power switch located directly behind the louvered panel of the compressor section. Also located behind the louver panel in the compressor section is the On/Off switch for the heater wires. On the remote units the thermostat may be provided with an **OFF** position which shuts off only the solenoid valve.



The power switch must be turned to the OFF position and power disconnected whenever doing the following:

- 1) Performing maintenance functions.
- 2) Cleaning the refrigerated cabinet area.
- 3) Performing service or repair functions.

Under no circumstances should the unit be operated without the louvered panel in place!

If receptacles are to be mounted in the unit backsplash, the power must be supplied from a separate electrical source and installed in accordance with the national Electrical Code and local electrical codes.



Electrical connection

Refer to the amperage data on the serial tag and your local code or the National Electrical Code to be sure the unit is connected to the proper power source. A protected circuit of the correct voltage and amperage must be run for connection of the line cord or permanent connection to the unit.

OPERATION

These units use a “cold wall” design — heat is removed from the storage compartments through the liner walls. Products next to or touching the walls of the compartment will often be colder than items at the center of the compartment. For best results, store items loosely and keep them away from the side walls as much as possible.

The units are not designed to reduce temperature quickly. When overloaded with warm items, it may

take several hours to return to normal temperature, Also, frequent or continuous opening of the lids can affect the temperature in the storage compartment.

Freezer compartments

Freezer compartments are designed to hold ice cream at 0°F to 5°F (-18°C to -15°C).

MAINTENANCE

Cleaning

The interior and exterior can be cleaned using soap and warm water. If this is not sufficient, try ammonia and water or non-abrasive liquid cleaner. When cleaning the exterior, always rub with the “grain” of the stainless steel to avoid marring the finish. Do not use an abrasive cleaner because it will scratch the stainless steel and plastic.

In order to maintain proper refrigeration performance, the condenser fins must be cleaned of dust, dirt, and grease regularly. It is recommended that this be done at least every three months. If conditions are such that the condenser is totally blocked in three months, the frequency of cleaning should be increased. Clean the condenser with a vacuum cleaner or stiff brush. If extremely dirty, a commercially available condenser cleaner may be required.

The compartment lids should be cleaned as required to maintain their ability to seal properly. A bristle brush and solution of soap and water should be all that is required to keep the lids clean. Do not use full strength degreasing agents on the rubber parts as they can cause the rubber to crack and become brittle.

Cleaning solutions need to be alkaline based or non-chloride cleaners. Any cleaner containing chlorides will damage the protective film of the stainless steel. Chlorides are also commonly found in hard water, salts, and household and industrial cleaners. If cleaners containing chlorides are used be sure to rinse repeatedly and dry thoroughly upon completion. Routine cleaning of stainless steel can be done with soap and water. Extreme stains or grease should be cleaned with a non-abrasive cleaner and plastic scrub pad. It is always good to rub with the grain of the steel. There are also stainless steel cleaners available which can restore and preserve the finish of the steels protective layer. Early signs of stainless steel breakdown can consist of small pits and cracks. If this has begun, clean thoroughly and start to apply stainless steel cleaners in attempt to restore the passivity of the steel.

Defrosting

These units do not have an automatic defrost system. Defrosting must be done manually after 3/8” frost accumulation. To defrost, turn the power switch to OFF. Allow the frost to melt and mop up with a sponge or soft cloth. When the defrost is complete, turn the power switch back to ON.



Do not use sharp utensils to scrape frost because they can damage important refrigeration components and scratch or dent the liner.

Expansion Valve Location

The expansion valve location for remote and self-contained models is located in the machine compartment of the unit.

Pressure Control

The temperature on self contained units is controlled by an adjustable pressure control located in the machine compartment. An adjustable control has the word COLDER near the knob, with an arrow to indicate the adjustment direction. These controls are field adjustable and do not require a service agent. If you have any questions, feel free to contact the Delfield Service Department.

In attempting to adjust the pressure control, you can do damage to your unit by accidentally adjusting the differential. Please make small incremental adjustments if a temperature adjustment is necessary, please contact the service department at Delfield (800) 733-8829 or your local service agent. Delfield is not responsible for charges incurred while having the pressure control adjusted.



Factory recommended low-pressure control settings for self-contained models are as follows:

Cut in 27# — cut out 11#
EPR valve for syrup rail is set at 65#

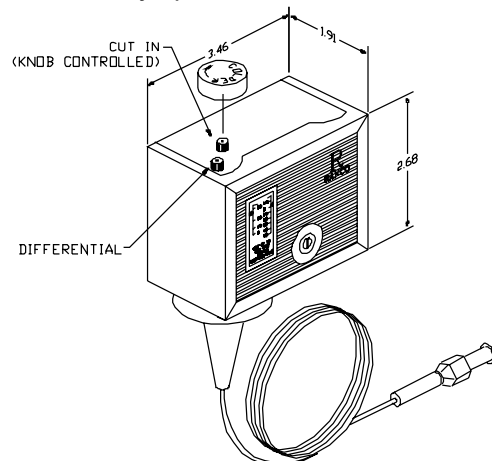

WIRING DIAGRAM: 13BC & WC SERIES

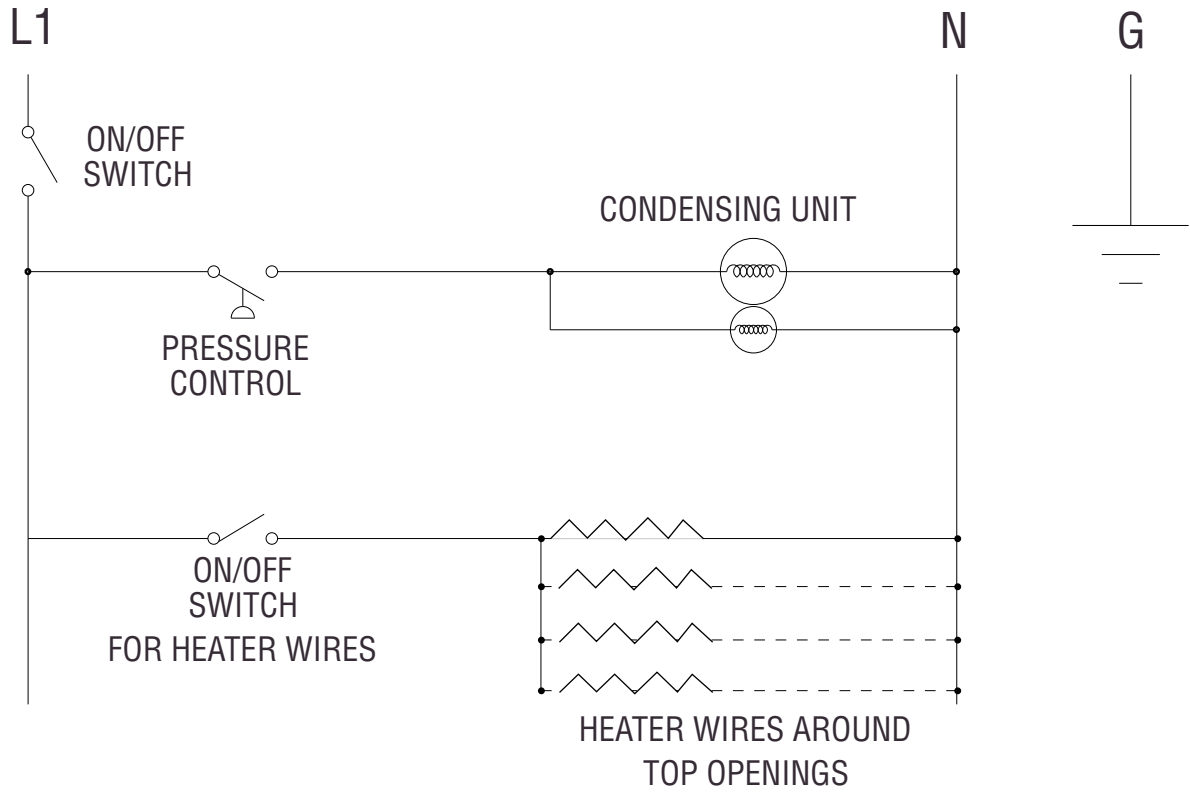

CONDENSING UNITS

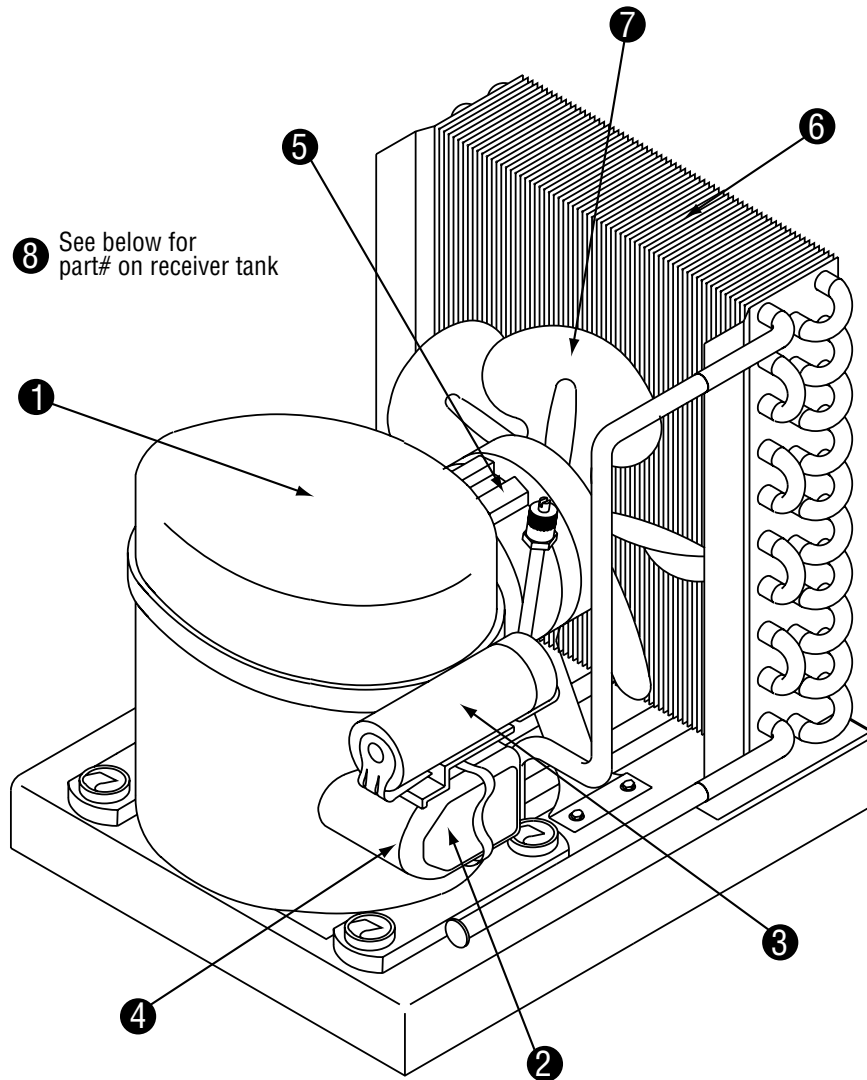

1/3 H.P. Condensing Units

KEY	DELFIELD PART#	COPELAND PART#	DESCRIPTION
	3526710	M4YL-0035-IAA-201	1/3 H.P. low condensing unit 404A
1	3526749	AS13C1E-1AA-908	compressor
2	2194469	040-C411-83	relay, current
3	2194452	014-0038-04	capacitor, starting
4	2194462	071-C100-38	overload protector
5	—	050-0259-10	motor fan
6	—	066-C223-00	coil, condenser
7	—	083-0122-00	blade, fan
8	—	077-C221-03	receiver tank

1/2 H.P. Condensing Units

KEY	DELFIELD PART#	COPELAND PART#	DESCRIPTION
	3526711	FJAF-A050-IAA-201	1/2 H.P. low condensing unit 404A
1	3526760	RS43C1E-IAA-958	compressor
2	2194473	040-0102-00	relay, current
3	2194458	014-0008-57	capacitor, starting
4	2194466	071-0329-15	overload protector
5	—	050-0259-10	motor fan
6	—	066-0303-00	coil, condenser
7	—	083-0130-00	blade, fan
8	—	577-0346-02	receiver tank

Used on all F13WC units and on F13BC44 and F13BC56.

Used on F13BC72 only.

REPLACEMENT PARTS LISTS

F13WR MODELS

REMOTE

Lid, large	3234188
Leg, 6" S/S, w/mount plate (4)	3234645
Valve, expansion, 1/4 Low, 404A	3516225
ON/OFF switch	2194099

F13WC MODELS SELF-CONTAINED

Lid, large	3234188
Louver, 14"	356-303-0030
Leg, 6" S/S, w/mount plate (4)	3234645
Condensing unit, 1/3 H.P., Low 404A	3526710
Valve, expansion, 1/4 Low, 404A	3516225
Cord & plug	2183348
ON/OFF switch	2194099

F13BR MODELS

REMOTE

Lid, small	3234187
Pump, chocolate	3234113
Jar, syrup, white "poly"	3234100
Pump, regular syrup	3234114
Cover, lift, lid & spoon	3234051
Jar, crushed fruit	3234099
Leg, 6" S/S, w/mount plate (4)	3234645
Valve, expansion, 1/4 Low, 404A	3516225
ON/OFF switch	2194099

F13BC MODELS SELF-CONTAINED

Lid, small	3234187
Pump, chocolate	3234113
Jar, syrup, white "poly"	3234100
Pump, regular syrup	3234114
Cover, lift, lid & spoon	3234051
Jar, crushed fruit	3234099
Louver, 14"	356-303-0030
Louver, 18"	356-303-0031
Leg, 6" S/S, w/mount plate (4)	3234645
Condensing unit, 1/3 H.P., Low 404A	3526710
Condensing unit, 1/2 H.P., Low 404A (72" only)	3526711
Valve, expansion, 1/4 Low, 404A	3516225
Valve, EPR 3/8 ODF, inlet/outlet	3516265
Control, low pressure	2193927
Cord & plug	2183348
ON/OFF switch	2194099

STANDARD REFRIGERANT CHARGES

1/3 low — 1/3 H.P. 24 oz. 404A

1/2 low — 1/2 H.P. 40 oz. 404A



There may be exceptions on specific models. Charge amount should match serial tag data.

STANDARD LABOR GUIDELINES TO REPAIR OR REPLACE PARTS ON DELFIELD EQUIPMENT

Advice and recommendations given by Delfield Service Technicians do not constitute or guarantee any special coverage.

- A maximum of 1-hour is allowed to **diagnose a defective component**.
- A maximum of 1-hour is allowed for **retrieval of parts** not in stock.
- A maximum **travel distance** of 100 miles round trip and 2-hours will be reimbursed.
- Overtime, installation/start-up, normal control adjustments, general maintenance, glass breakage, freight damage, and/or correcting and end-user installation error will not be reimbursed under warranty unless pre-approved with a **Service Work Authorization** from Delfield. You must submit the number with the service claim.

LABOR OF 1-HOUR IS ALLOWED TO REPLACE:

- Thermostat
- Transformer
- Solenoid Coil
- Hi-limit/Thermal Protector Switch
- Compressor Start Components and Overload Protector
- Defrost Timer
- Thermometer
- Contactor/Relay
- Evaporator/Condenser Fan Motor and Blade
- Circulating Fan Motor and Blade
- Fan Delay/Defrost Termination Switch
- Door Hinges, Locks, and Gaskets
- Condensate Element

LABOR OF 2 HOURS TO REPLACE:

- Defrost Element
- Solenoid Valve
- Pressure Control
- Locate/Repair Leak

LABOR OF 3 HOURS TO REPLACE:

- EPR or CPR Valve
- Expansion Valve
- Condenser or Evaporator Coil

LABOR OF 4 HOURS TO REPLACE

- Compressor

This includes recovery of refrigerant and leak check.

\$55.00 maximum reimbursement for refrigerant recovery (includes recovery machine, pump, torch, oil, flux, minor fittings, solder, brazing rod, nitrogen, or similar fees.)

REFRIGERANTS

- R404A A maximum of \$12.00/lb. or 75¢/oz. will be reimbursed.

STANDARD ONE YEAR WARRANTY (One year parts, 90 days labor.)

The Delfield Company (“Delfield”) warrants to the Original Purchaser of the Delfield product (herein called the “Unit”) that such Unit, and all parts thereof, will be free from defects in material and workmanship under normal use and service for a period of one (1) year from the date of shipment of the Unit to the Original Purchaser **or, if the Original Purchaser returns the warranty card completely filled out including the date of installation within thirty (30) days of receipt of the Unit, one (1) year from the date of installation.** During this one year warranty period, Delfield will repair or replace any defective part or portion thereof returned to Delfield by the Original Purchaser which Delfield determines was defective due to faulty material or workmanship. The Original purchaser will pay all labor, crating, freight and related costs incurred in the removal of the Unit of defective component and shipment to Delfield, except that during a period of either ninety (90) days from the date of shipment of the Unit to the Original Purchaser or, if the Original Purchaser returns the warranty card completely filled out including the date of installation within thirty (30) days of receipt of the Unit, ninety (90) days from the date of installation Delfield will pay all related labor costs. Delfield will pay the return costs if the Unit or part thereof was defective.

The term “Original Purchaser” as used herein means that person, firm, association, or corporation for whom the Unit was originally installed.

This warranty does not apply to any Unit or part thereof that has been subjected to misuse, neglect, alteration, or accident, such as accidental damage to the exterior finish, operated contrary to the recommendations specified by Delfield; or repaired or altered by anyone other than Delfield in any way so as to, in Delfield’s sole judgement, affect its quality or efficiency. This warranty does not apply to any Unit that has been moved from the location where it was originally installed. This warranty also does not cover the refrigerator drier or the light bulbs used in the Unit. **The warranty is subject to the user’s normal maintenance and care responsibility as set forth in the Service and Installation Manual, such as cleaning the condenser coil, and is in lieu of all other obligations of Delfield. Delfield neither assumes, nor authorizes any other person to assume for Delfield, any other liability in connection with Delfield’s products.**

Removal or defacement of the original Serial Number or Model Number from any Unit shall be deemed to release Delfield from all obligations hereunder or any other obligations, express or implied.

Parts furnished by suppliers to Delfield are guaranteed by Delfield only to the extent of the original manufacturer’s express warranty to Delfield. Failure of the Original Purchaser to receive such manufacturer’s express warranty to Delfield. Failure of the Original Purchaser to receive such manufacturer’s warranty shall in no way create any warranty, expressed or implied, or any other obligation or liability on Delfield’s part in respect thereof.

IF THE CUSTOMER IS USING A PART THAT RESULTS IN A VOIDED WARRANTY AND A DELFIELD AUTHORIZED REPRESENTATIVE TRAVELS TO THE INSTALLATION ADDRESS TO PERFORM WARRANTY SERVICE, THE SERVICE REPRESENTATIVE WILL ADVISE CUSTOMER THE WARRANTY IS VOID. SUCH SERVICE CALLS WILL BE BILLED TO CUSTOMER AT THE AUTHORIZED SERVICE CENTER’S THEN APPLICABLE TIME AND MATERIALS RATES. CONSIDER: CUSTOMER MAY INITIATE A SERVICE AGREEMENT WITHOUT PARTS COVERAGE.

If shipment of a replacement part is requested prior to the arrival in the Delfield factory of the part claimed to be defective, the Original Purchaser must accept delivery of the replacement part of a C.O.D. basis, with credit being issued after the part has been received and inspected at Delfield’s plant and determined by Delfield to be within this warranty.

Under no condition does this warranty give the Original Purchaser the right to replace the defective Unit with a complete Unit of the same manufacturer or of another make. Unless authorized by Delfield in writing, this warranty does not permit the replacement of any part, including the motor-compressor, to be made with the part of another make or manufacturer.

No claims can be made under this warranty for spoilage of any products for any reason, including system failure.

The installation contractor shall be responsible for building access, entrance and field conditions to insure sufficient clearance to allow any hood(s), vent(s), or Unit(s) if necessary, to be brought into the building. Delfield will not be responsible for structural changes or damages incurred during installation of the Unit or any exhaust system.

Delfield shall not be liable in any manner for any default or delay in performance hereunder caused by or resulting from any contingency beyond Delfield’s control, including, but not limited to, war, governmental restrictions or restraints, strike, lockouts, injunctions, fire, flood, acts of nature, short or reduced supply of raw materials, or discontinuance of the parts by the original part manufacturer.

Except as provided in any Additional Four Year Protection Plan, if applicable, and the Service Labor Contract, if applicable, the foregoing is exclusive and in lieu of all other warranties, whether written or oral, express or implied. This warranty supersedes and excludes any prior oral or written representations or warranties. Delfield expressly disclaims any implied warranties of merchantability, fitness for a particular purpose of compliance with any law, treaty, rule or regulation relating to the discharge of substances into the environment. The sole and exclusive remedies of any person relating to the Unit, and the full liability of Delfield for any breach of this warranty, will be as provided in this warranty.

Other than this Delfield Standard One Year Limited Warranty, any applicable Delfield Additional Four Year Protection Plan or applicable Delfield Service Labor Contract, the Original Purchaser agrees and acknowledges that no other warranties are offered or provided in connection with or for the unit or any other part thereof.

In no event will Delfield be liable for special, incidental or consequential damages, or for damages in the nature of penalties.

IF DURING THE WARRANTY PERIOD, CUSTOMER USES A PART FOR THIS DELFIELD EQUIPMENT OTHER THAN AN UNMODIFIED NEW OR RECYCLED PART PURCHASED DIRECTLY FROM DELFIELD OR ANY OF ITS AUTHORIZED SERVICE CENTERS AND/OR THE PART BEING USED IS MODIFIED FROM ITS ORIGINAL CONFIGURATION, THIS WARRANTY WILL BE VOID. FURTHER, DELFIELD AND ITS AFFILIATES WILL NOT BE LIABLE FOR ANY CLAIMS DAMAGES OR EXPENSES INCURRED BY THE CUSTOMER WHICH ARISE DIRECTLY OR INDIRECTLY, IN WHOLE OR IN PART, DUE TO THE INSTALLATION OF ANY MODIFIED PART AND/OR PART RECEIVED FROM AN UNAUTHORIZED SERVICE CENTER. If the warranty becomes void, Customer may purchase from Delfield, if available, a Service Agreement or service at the then current time and materials rate.

For more information on Delfield warranty’s log on and check out the service section of our web site at www.delfield.com.



ADDITIONAL FOUR YEAR PROTECTION PLAN (for Motor-Compressor only)

Delfield Model#	Serial #	Installation Date

In addition to the Standard One Year Warranty on the Motor-Compressor contained in the above listed Delfield product (the "Unit"), The Delfield Company ("Delfield") also agrees to repair, or exchange with similar or interchangeable parts in design and capacity at Delfield's option, the defective Motor-Compressor contained in the Unit (the "Motor-Compressor), or any part thereof, for the Original Purchaser only, at any time during the four (4) years following the initial one (1) year period commencing on the date of installation for the Original Purchaser. **Failure of the Original Purchaser to register the registration card containing the Original Purchasers name, address, date of installation, model number and serial number of the Unit containing the Motor-Compressor within 30 days from the date of installation shall void this warranty.** This additional warranty is only available if the Motor-Compressor is inoperative due to defects in material or factory workmanship, as determined by Delfield in its sole judgement and discretion. The Original Purchaser shall be responsible for returning the defective Motor-Compressor to Delfield prepaid, F.O.B. at the address shown on the back cover of this manual.

The term "Original Purchaser" as used herein means that person, firm, association, or corporation for whom the Unit was originally installed.

The term "Motor-Compressor" as used herein does not include unit base, air or water cooled condenser, receiver, electrical accessories such as relay, capacitors, refrigerant controls, or condenser fan/motor assembly. This warranty does not cover labor charges incidental to the replacement of parts. This warranty further does not include any equipment to which said condensing unit is connected, such as cooling coils, temperature controls or refrigerant metering devices. This warranty shall be void if the Motor-Compressor, in Delfield's sole judgement, has been subjected to misuse, neglect, alteration or accident, operated contrary to the recommendations specified by the Unit manufacturer, repaired or altered by anyone other than Delfield in any way so as, in Delfield's sole judgment, to affect its quality or efficiency or if the serial number has been altered, defaced or removed. This Warranty does not apply to a Motor-Compressor in any Unit that has been moved from the location where it was originally installed. The addition of methyl chloride to the condensing unit or refrigeration system shall void this warranty.

General Conditions

Delfield shall not be liable in any manner for any default or delay in performance hereunder caused by or resulting from any contingency beyond Delfield's control, including, but not limited to, war, governmental restrictions or restraints, strike, lockouts, injunctions, fire, flood, acts of nature, short or reduced supply of raw materials, or discontinuance of any part or the Motor-Compressor by the unit manufacturer.

Replacement of a defective Motor-Compressor is limited to one (1) Motor-Compressor by us during the four (4) year period. Delfield shall replace the Motor-Compressor at no charge.

This warranty does not give the Original Purchaser of the Motor-Compressor the right to purchase a complete replacement Motor-Compressor of the same make or of another make. It further does not permit the replacement to be made with a Motor-Compressor of another kind unless authorized by Delfield. In the event Delfield authorizes the Original Purchaser to purchase a replacement Motor-Compressor locally, only the wholesale cost of the Motor-Compressor is refundable.

Expressly excluded from this warranty are damages resulting from spoilage of goods.

Except as provided in any applicable Standard One Year Limited Warranty or applicable Service Labor Contract, the foregoing is exclusive and in lieu of all other warranties, whether written or oral, express or implied. This Warranty supersedes and excludes any prior oral or written representations or warranties. Delfield expressly disclaims any implied warranties of merchantability, fitness for a particular purpose or compliance with any law, treaty, rule or regulation relating to the Motor-Compressor, and the full liability of Delfield for any breach of this warranty, will be as provided in this warranty.

Other than any applicable Delfield Standard One year Limited Warranty, this Delfield Additional Four Year Protection Plan and any applicable Delfield Service Labor Contract, the Original Purchaser agrees and acknowledges that no other warranties are offered or provided in connection with or for the Motor-Compressor or any part thereof.

In no event will Delfield be liable for special, incidental or consequential damages, or for damages in the nature of penalties.



NOTES:



Mt. Pleasant, MI



Covington, TN

Thank you for choosing Delfield!

Help is a phone call away. Help our team of professional, courteous customer service reps by having your model number and serial number available at the time of your call (800) 733-8829.

Model: _____ S/N: _____

Installation Date: _____



**For a list of Delfield's authorized parts depots,
visit our website at www.delfield.com.**

