



# 307 Series

Glass Filler

Project \_\_\_\_\_

Item \_\_\_\_\_

Quantity \_\_\_\_\_

CSI Section 11400

Approved \_\_\_\_\_

Date \_\_\_\_\_

# 307 Series Glass Filler

## Models

- 307 Glass filler



307

## Standard Features

- Glass filler is 9.5" high
- Chrome plated wire strainer
- One year parts and 90 day labor standard warranty

## Options & Accessories

- Pitcher filler

## Specifications

Top is 20-gauge stainless steel with die-stamped perimeter and die-stamped drain opening fitted with chrome-plated wire strainer and 1" (25 mm) diameter drain fitting. Unit comes with 9.5" (24 cm) high glass filler.



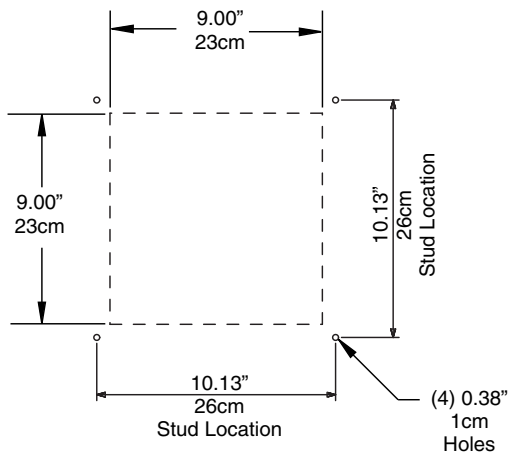

**Cutout Dimensions**

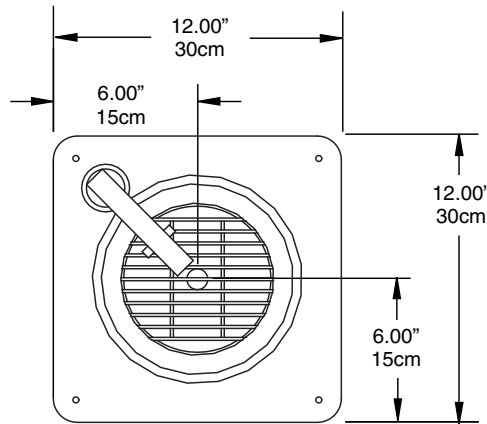

**Plan View**

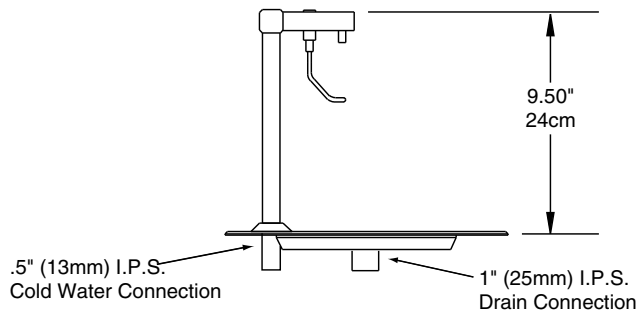

**Side View**

Specifications					
Model	L	W	D	Cutout Dimension	Ship Weight
307	12" (30cm)	12" (30cm)	9.5" (24cm)	9" x 9" & (4) 0.38" Holes 23cm x 23cm & (4) 1cm Holes	7lbs (3kg)

Delfield reserves the right to make changes to the design or specifications without prior notice.