



# 250

## Undercounter Sink, Ice And Water Station

Project \_\_\_\_\_  
 Item \_\_\_\_\_  
 Quantity \_\_\_\_\_  
 CSI Section 11400  
 Approved \_\_\_\_\_  
 Date \_\_\_\_\_

250 Undercounter Sink, Ice And Water Station

### Models

- 250 Undercounter sink, ice chest and water station



Model 250

### Standard Features

- 18-gauge stainless steel top with raised die stamped opening
- Galvanized exterior body
- 9" x 14" x 10" stainless steel sink
- Deck mount faucet
- Ice chest lift off cover shall be one piece stainless with handle
- Ice chest capacity is 45lbs.
- 1" diameter drain plumbed out the ice chest bottom
- High density environmentally friendly, Kyoto Protocol Compliant, Non ODP (Ozone Depletion Potential), Non GWP (Global Warming Potential) polyurethane foam throughout unit
- ABS plastic ice station interior line with coved corners
- Glass filler is 9.5" high, over a die stamped drain opening fitted chrome plated wire strainer
- One year parts and 90 day labor standard warranty

### Options & Accessories

- Pitcher filler

### Specifications

Top is 18-gauge stainless steel, has 6" (15.2cm) risers on back and sides, 1.62" (4.11cm) turn-down on front edge. Top has 9" x 14" (22.9cm x 35.6cm) sink welded in place, comes with chrome-plated faucet set. Top mounted 9.5" (24.1cm) glass filler, has die-stamped drain opening with chrome-plated wire strainer. Ice chest opening is 10.5" x 15.13" (26.7 x 38.4 cm), die-stamped with .19" (.48cm) raised edge and has one-piece lift-off cover in 20-gauge stainless steel. Ice bin capacity is 45 pounds.

Ice bin liner is high-impact ABS plastic with coved corners and pitched to 1" (2.54cm) diameter drain. Bin insulated on sides and bottom with high-density environmentally friendly, Kyoto Protocol Compliant, Non ODP (Ozone Depletion Potential), Non GWP (Global Warming Potential) polyurethane.

Outside body is 24-gauge galvanized steel. Unit comes with 13.19" x 45.75" (33.5cm x 116cm) front panel in 20-gauge stainless steel for field installation.



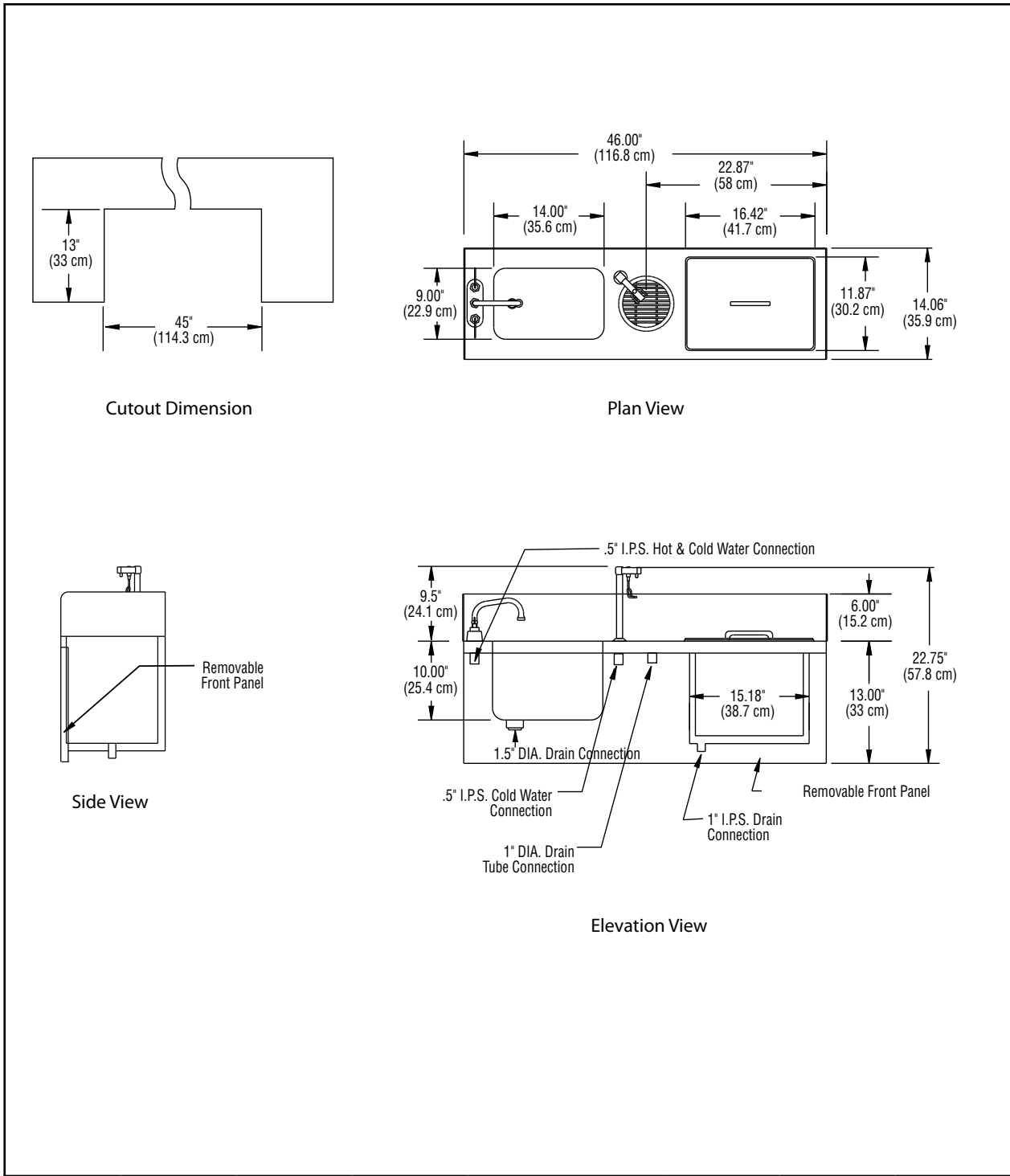

Specifications							
Model	L	D	H	Counter Cutout Dimension	Ice Capacity	Ship Weight	Freight Class
250	46" (116.8cm)	14.12" (35.9cm)	22.75" (57.8cm)	45" x 13" (114.3cm x 33.0cm)	45lbs (20kg)	81lbs (37kg)	85

Delfield reserves the right to make changes to the design or specifications without prior notice.

250 Undercounter Sink, Ice And Water Station