

(FASTRON.)<sup>®</sup>

## MEC-110 MERIDIAN SERIES

Built-In Cooking Controller  
10 Product Keys



Meridian<sup>™</sup>

### The (FASTRON.)<sup>®</sup> Meridian<sup>™</sup> Cooking Controller

A direct replacement for the popular (FASTRON.)<sup>®</sup> Silver Edition<sup>™</sup> Series controller or for fryers that have electromechanical or non-FAST controls.

#### Ensure Food Safety and Quality

Product that is undercooked or held too long in the Danger Zone (40°-140°F/5°-60°C) can potentially expose your customers and crew to dangerous food-borne illness. Bacteria multiplication can be prevented by controlling the time a product is cooked and/or held. The Meridian helps operators avoid food safety dangers by automatically monitoring these cook and hold times. Precisely timed products deliver consistently good-tasting food to your customers. Hold timers also ensure that expired product is never served.

#### Increase Yields

Independent tests show the (FAST.Flex)<sup>™</sup> cooking curve provides the best and most consistent yields across load sizes and cooking temperatures, regardless of product temperature and moisture content. A reduction in food waste can also be realized.

#### Easy to Program

(FAST.Nav)<sup>™</sup> mobile phone style and predictive text programming reduces training time and increases productivity.

#### User-Friendly Messaging

14-segment 8-character displays allow a greater range of names and prompts to be used. Create your own product menu and action alarm names, or choose from a pre-programmed library of standard menu items.

### Interchangeable with Other Fryers

Easily move your Meridian to another fryer eliminating the need to purchase a new control. The controller can be configured to work on fryers from a variety of manufacturers.

### Secure Operation

Separate pass codes for store managers and employees prevent unauthorized re-programming.

### Energy Savings (optional)

Save energy dollars with FAST's patented Set Back feature. The controller will automatically lower the appliance's temperature during inactive periods.

### Filter Lockout Oil

Reduce costs by extending the usable life of your oil with FAST's patented SmartStat<sup>™</sup> temperature control technology. Filtering your oil at pre-set time(s) of the day will not only give you longer oil life, but will also improve product flavor and reduce the amount of time and labor it takes to change out the oil.

### 24/7 Technical Support

As with all (FAST.) products, the (FASTRON.) Meridian comes with 24-hour programming assistance via toll-free phone.

### Standard Meridian Features

- ✓ 10 Product Keys to support ever-changing menus. More space for LTOs (limited time offers).
- ✓ Fully RoHS compliant
- ✓ Larger LED displays with 8 characters
- ✓ Appliance mode front-panel selectable: gas, electric, propane, etc.

- ✓ Replaceable menu strip for quick and easy menu changes.
- ✓ Replaceable feature key menu strip with globalized symbols
- ✓ SCK Xwire<sup>™</sup> wireless communications compatible for the networked kitchen
- ✓ (FAST.Edit)<sup>®</sup> and (FAST.Transfer)<sup>™</sup> compatible. Reduces time and cost to change recipes. Ensures consistent recipes across all appliances / restaurants.

### Optional Meridian PLUS Features

- ✓ Product and Action Alarm name library programming
- ✓ Adjustable audio alarm levels
- ✓ Diagnostic feature to assist with testing all inputs and outputs
- ✓ 3 pre-programmed fryer types (Universal Appliance Control)
- ✓ Energy-saving "set back" mode
- ✓ 3 action alarms per key
- ✓ 10 cooking stages instead of one
- ✓ Twice the hold times
- ✓ Filter lockout oil management
- ✓ SCK Link<sup>®</sup> software giving you the most advanced communications capability available for HACCP reporting and automated on-line kitchen management.



(FAST.)<sup>®</sup>

the time is right.

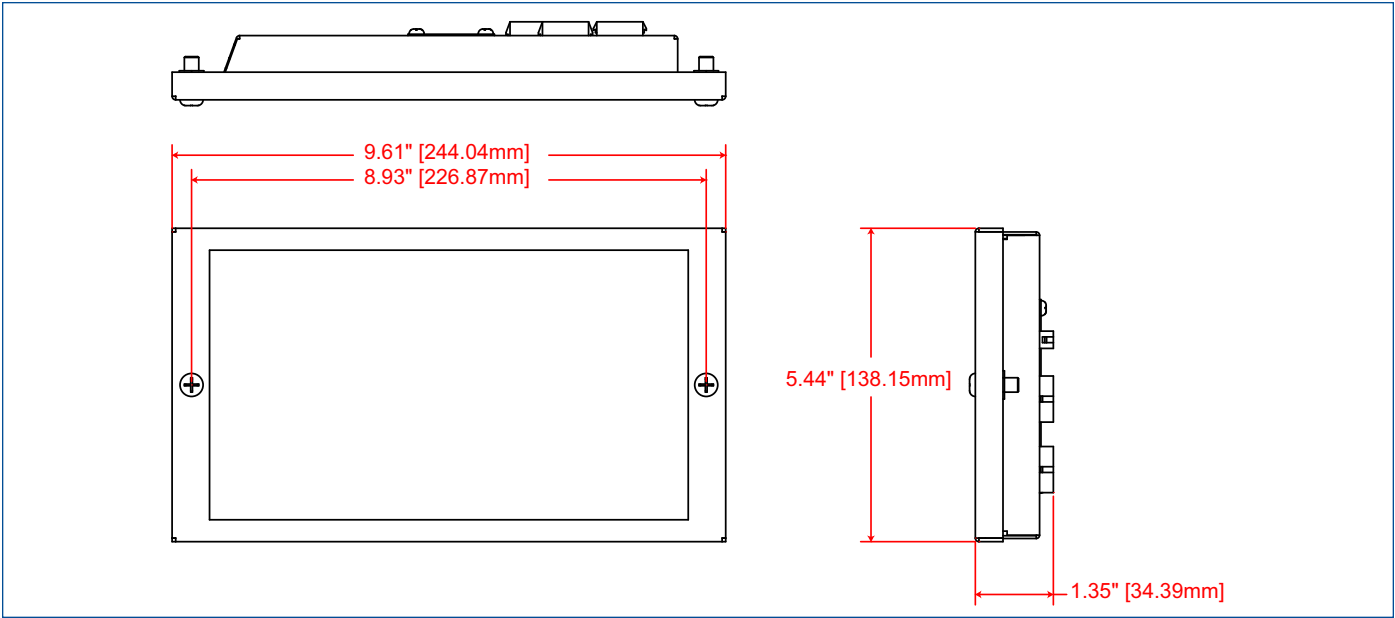

### SPECIFICATIONS

#### MECHANICAL

- Controller: .060 aluminum front panel
- Chassis: .040 aluminum
- Faceplate: polyester with back-printed text and removable menu strip
- Maximum ambient temperature: 158°F / 70°C, 90% max. RH non-condensing

#### ELECTRICAL

- Power Input: 24VAC 50/60 Hz +/- 10% supplied externally
- Digital Inputs: Four 24VDC or AC
- Temperature Inputs: 1 or 2 temperature sensing thermistor probes
- Outputs: Up to 8 DC outputs to drive remote relays, control heat sources, basket lifts and solenoid valves, or other requirements
- Surface mounted circuit design
- Switch life rating: >1 million cycles
- Status indicators rated life: 50,000 hours
- Noise spike protection: 4,000 Volt (minimum) (\*on timers and all properly installed controls)

#### SHIPPING WEIGHT

- Approx. 3 lbs. (1.4 Kg)

### ORDERING INFO

- |              |  |
|--------------|--|
| RM1-60210-04 | 10 Product Meridian,<br>1 Probe, Built-in, 24V         |
| RM1-60210-09 | 10 Product Meridian<br>PLUS, 1 Probe, Built-in,<br>24V |

Consult factory for other applications.



COMMERCIAL COOKING APPLIANCES ALSO CLASSIFIED BY ETL IN ACCORDANCE WITH NSF STANDARD NO. NSF 189. DESIGN EVALUATED BY ETL IN ACCORDANCE WITH ANSIA/CAN/CSA 14.6-07.



# (FAST.)<sup>®</sup>

**Food Automation - Service Techniques, Inc.**  
905 Honeyspot Road  
Stratford, CT 06615-7147 USA

Phone: +1-203-377-4414  
Sales: **1-800-FASTRON**  
Fax: +1-203-377-8187  
International Callers: +1-203-378-6860

**www.fastinc.com**

Toll-free technical support 24/7 from the U.S., Canada, and Caribbean: **1-800-243-9271**

This document contains confidential information. The dissemination, publication, copying, or duplication of this document without prior written authorization is strictly prohibited.

Specifications subject to change without notice.

### International offices are located in the United Kingdom, China and Singapore:

*Europe, Middle East, Africa, South Asia*  
FAST INTERNATIONAL  
31 Saffron Court  
Southfields Business Park  
Basildon, Essex SS15 6SS ENGLAND  
Phone: +44 0 1268-544000

*Asia Pacific*  
1803, 18F, No 922 Hengshan Rd  
Shanghai 200030, CHINA  
Phone: +86-13916 854 613

15-101, Block 290G, Bukit Batok St. 24  
SINGAPORE 65629  
Phone: +65 98315927

### WARRANTY

FAST warrants all new timers, computers, and controllers for 1 year from the date of purchase including computers, controllers, and timers. FAST warrants all other items for a period of 90 days unless otherwise stated at the time of purchase.

### PATENTS

The products manufactured by FAST are protected under one or more of the following U.S. Patents:

4,782,445	4,812,625	4,812,963	4,864,498
4,911,068	4,920,948	5,043,860	5,171,974
5,331,575	5,539,671	5,711,606	5,723,846
5,726,424	5,875,430	6,142,666	6,339,930
6,401,467	6,505,546	6,581,391	7,015,433

Plus foreign patents and patents pending. Plus licensed patent 5,973,297

SCK Link<sup>®</sup> is a registered trademark of Technology Licensing Corporation and use is subject to the appropriate license agreement.