

HCD1000R, HCD1000N Icemakers

Order parts online
www.follettice.com

Operation and Service Manual

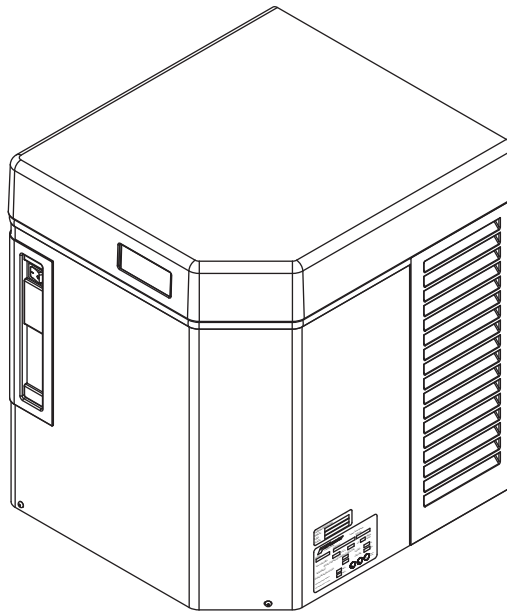

**Following installation, please forward this manual
to the appropriate operations person.**

**Follett Corporation
Equipment Return Policy**

Follett equipment may be returned for credit under the following conditions:

1. The equipment is new and unused.
2. A return authorization number has been issued by customer service within 30 days after shipment.
3. Follett receives the equipment at the factory in Easton, PA within 30 days after issuance of the return authorization number.
4. The equipment must be returned in Follett packaging. If the packaging has been damaged or discarded, Follett will forward, at the customer's expense, new packaging.

Note: Return freight charges are the responsibility of the customer. If equipment is returned and is damaged because of improper packaging, Follett Corporation will not be held responsible.

Credit will be issued when:
The equipment has been inspected by Follett and deemed suitable to be returned to stock.

Note: A 15% restocking charge will be deducted from the credit. If the cost to return the product to stock exceeds 15%, the actual cost will be deducted.

Table of contents

Welcome to Follett Corporation	4
Specifications	5
Operation	7
Cleaning, weekly exterior care	7
Cleaning, semi-annual evaporator cleaning	7
Service	12
Icemaker operation	12
Water system	13
Electrical system	14
Normal control board operation	14
Test points	15
Time delay and self-flushing jumpers	15
Error faults	15
Hard errors	15
Soft errors	15
Relay output indication	16
Compressor/refrigerant solenoid output	16
Wiring diagram, evaporator unit	17
Wiring diagram, condenser unit	18
Gearmotor data	18
Mechanical system	19
Evaporator disassembly	19
Evaporator reassembly	21
Refrigeration system	24
Condenser unit operation	24
Refrigerant pressure data	24
Refrigerant charges	24
Refrigeration system diagram	25
Refrigerant replacement requirements	26
Evacuation	26
Ambients (evaporator unit)	26
Ice capacity test	26
Bin full detection system	27
Troubleshooting	28
Replacement parts	30

Welcome to Follett

Follett equipment enjoys a well-deserved reputation for excellent performance, long-term reliability and outstanding after-the-sale support. To ensure that this equipment delivers the same degree of service, we ask that you review the installation manual (provided as a separate document) before beginning to install the unit. Our instructions are designed to help you achieve a trouble-free installation. Should you have any questions or require technical help at any time, please call our technical service group at (800) 523-9361 or (610) 252-7301.

Before you begin

After uncrating and removing all packing material, inspect the equipment for concealed shipping damage. If damage is found, notify the shipper immediately and contact Follett Corporation so that we can help in the filing of a claim, if necessary.

Check your paperwork to determine which model you have. Follett model numbers are designed to provide information about the type and capacity of Follett equipment. Following is an explanation of the different model numbers in the 1000 series.

Horizon Series Icemaker Model Number Configurations

<div style="display: flex; justify-content: space-around; align-items: center;"> <div style="border: 1px solid black; padding: 2px 5px;">HC</div> <div style="border: 1px solid black; padding: 2px 5px;">D</div> <div style="border: 1px solid black; padding: 2px 5px;">1000</div> <div style="border: 1px solid black; padding: 2px 5px;">R</div> <div style="border: 1px solid black; padding: 2px 5px;">V</div> <div style="border: 1px solid black; padding: 2px 5px;">S</div> </div>					
Icemaker Model Series	Voltage	Capacity Model Series	Condenser	Application	Configuration
HC Horizon Chewblet®	D Low side 115/60/1 Condenser 208-230/60/1 <i>(remote condensing only)</i>	1000 up to 1036 lbs (471kg)	A Air-cooled, self-contained W Water-cooled, self-contained	V Vision™ H Harmony™	S Satellite-fill™ T Top-mount
	C 208-230/60/1 <i>(self-contained only)</i>	1400 up to 1450 lbs (658kg)	R Air-cooled, remote condensing unit N Air-cooled, no condensing unit for connection to parallel rack system	B Ice storage bin J Drop-in	
	E 230/50/1 <i>(self-contained only)</i>				

Chewblet is a registered trademark of Follett Corporation, registered in the US.

CAUTION

- Outdoor installation of low side is not recommended and will void warranty.
- Moving parts. Do not operate with front cover removed.
- Hot parts. Do not operate with cover removed.
- To reduce risk of shock, disconnect power before servicing.
- Most ice machine cleaners contain citric or phosphoric acid, which can cause skin irritation. Read caution label on product and follow instructions carefully.
- Ice is slippery. Maintain counters and floors around dispenser in a clean and ice-free condition.
- Ice is food. Follow recommended cleaning instructions to maintain cleanliness of delivered ice.

Specifications

Electrical

Separate circuit and equipment ground required.

Evaporator unit

Standard electrical – 115/60/1

Maximum fuse – 15 amps

Amperage – 6 amps

Condenser unit

Standard electrical – 220V, 60Hz, 1 phase

Maximum fuse – 30 amps

Amperage – 17.6 amps

Evaporator plumbing

3/8" OD push-in water inlet

3/4" MPT

Notes: 3/4" vented drain line must slope a minimum of 1/4" per foot (6mm per 30.4cm run).

Drain to be hard piped and insulated.

Water shut-off recommended within 10 feet (3m).

Follett recommends installation of Follett water filter system (part# 00130286) in icemaker inlet water line.

Ambient

Evaporator unit

Air temperature 100°F/38°C max.

50°F/10°C min.

Water temperature 90°F/32°C max.

45°F/7°C min.

Water pressure 70 psi max. (483 kPa)

10 psi min. (69 kPa)

Condenser unit

Air temperature 120°F/49°C max.

- 20°F/-29°C min.

Refrigeration

3/8" liquid line

5/8" suction line

Note: Rack system installations require a reserve capacity of 7,500 BTU/hr at 2°F (-17°C) evaporator temperature.

Evaporator pressure regulator (not supplied) is required.

Weight

Evaporator unit

160 lbs (73kg)

Condenser unit

265 lbs (120kg)

Ice production

Air-cooled icemaker capacity/24 hrs.

		Ambient Air Temperature F/C						
		F	60	70	80	90	100	
Inlet Water Temperature F/C	C	16	21	27	32	38		
	50	1101	1036	969	901	811	lbs	
	10	499	470	440	409	368	kg	
	60	1045	980	913	845	755	lbs	
	16	474	445	414	383	342	kg	
	70	990	925	858	790	700	lbs	
	21	449	420	389	358	318	kg	
	80	935	870	803	735	645	lbs	
	27	424	395	364	333	293	kg	
	90	879	814	747	679	589	lbs	
	32	399	369	339	308	267	kg	

Dimensions and clearances

Entire front of icemaker must be clear of obstructions/connections to allow removal.

1" (26mm) clearance above icemaker for service.

1" (26mm) minimum clearance on sides.

Front View

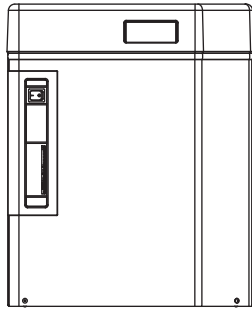

Side View

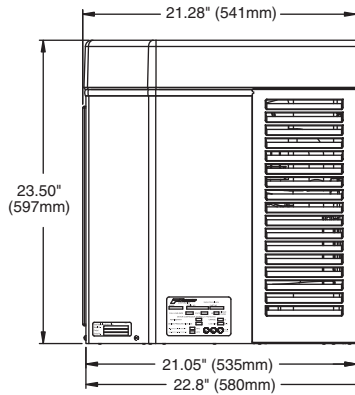

Back View

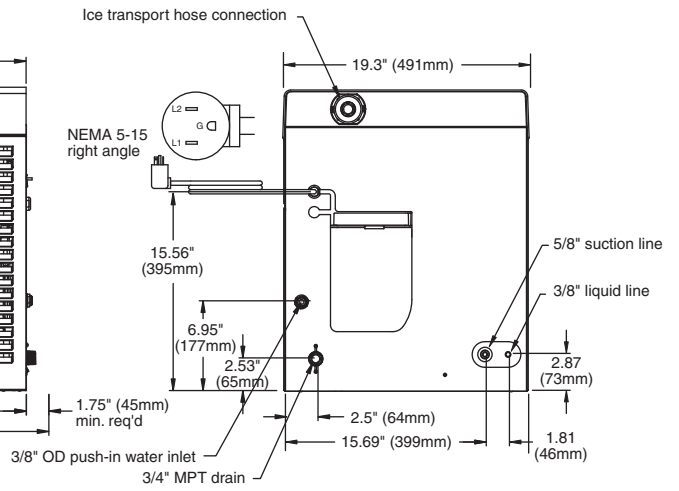

Condenser Front View

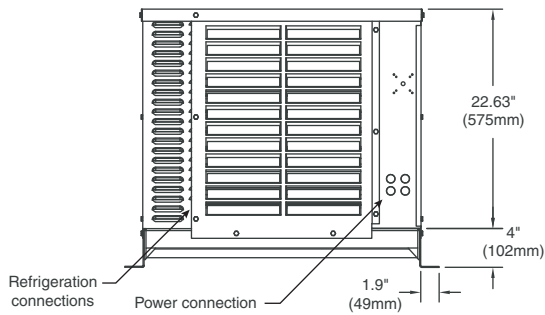

Condenser Side View

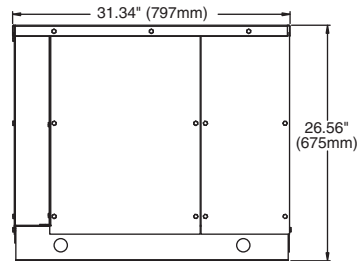

Operation

Cleaning and preventive maintenance (all models)

Note: Do not use bleach to sanitize or clean the icemaker.

Preventive maintenance

Periodic cleaning of Follett's icemaker system is required to ensure peak performance and delivery of clean, sanitary ice. The recommended cleaning procedures that follow should be performed at least as frequently as recommended, and more often if environmental conditions dictate.

Cleaning of the condenser can usually be performed by facility personnel. Cleaning of the icemaker system, in most cases, should be performed by your facility's maintenance staff or a Follett authorized service agent. Regardless of who performs the cleaning, it is the operator's responsibility to see that this cleaning is performed according to the schedule below. Service problems resulting from lack of preventive maintenance will not be covered under the Follett warranty.

Weekly exterior care

The exterior may be cleaned with a stainless cleaner such as 3M Stainless Steel Cleaner & Polish or equivalent.

Monthly condenser cleaning (air-cooled icemaker only)

1. Use a vacuum cleaner or stiff brush to carefully clean condenser coils of air-cooled icemakers to ensure optimal performance.
2. When reinstalling counter panels in front of remote icemakers, be sure that ventilation louvers line up with condenser air duct.

Semi-annual evaporator cleaning (every 6 months)

WARNING

- Wear rubber gloves and safety goggles (and/or face shield) when handling ice machine cleaner or sanitizer.

CAUTION

- Use only Follett approved SafeCLEAN™ Cleaner (part #00132001) and NU-CALGON IMS-II SANITIZER.
- Do not mix Cleaner and Sanitizer solutions together.
- DO NOT USE BLEACH.
- It is a violation of Federal law to use these solutions in a manner inconsistent with their labeling.
- Read and understand all labels printed on packaging before use.

Note: Complete procedure for cleaning and sanitizing MUST be followed. Ice must be collected for 10 minutes before putting ice machine back into service.

1. To clean – Remove cover. Press the CLEAN button. The machine will drain. Wait for the LO WATER light to come on (Fig. 1).

Fig. 1

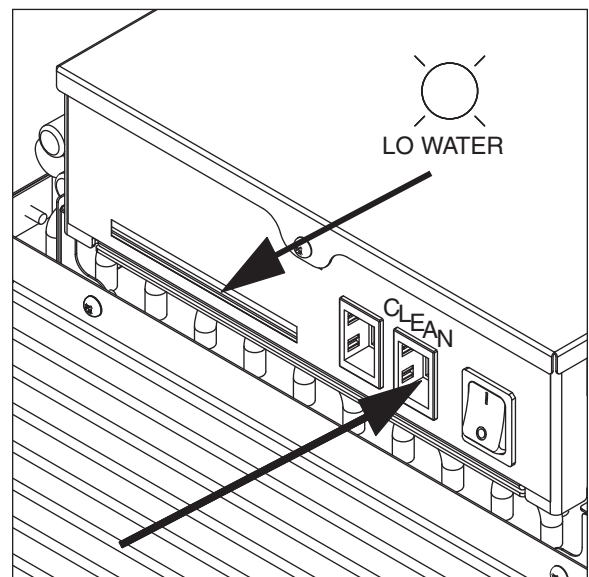

- Mix 1 gallon (3.8L) 120°F (49°C) water and 7 ounces (198g) (one 7 ounce packet of Follett SafeCLEAN ice machine cleaner, part#-00132001). Locate cleaning cup. Fill until HI WATER light comes on (Fig. 2).

Note: Do not use bleach to sanitize or clean the icemaker.

Fig. 2

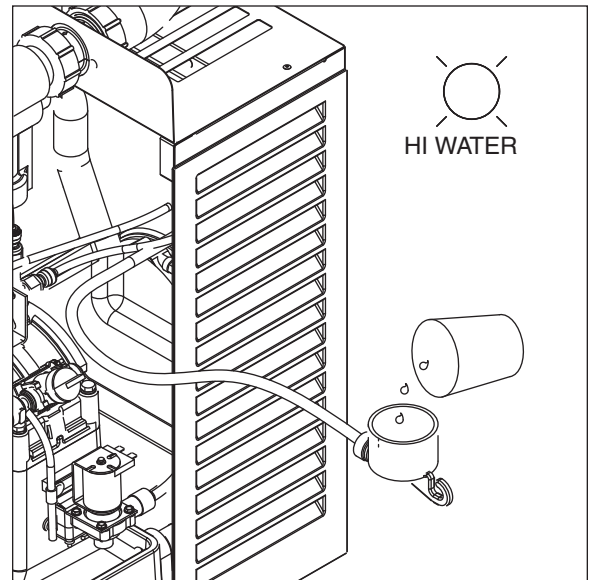

- Replace cover on cleaning cup. Wait until machine restarts. Machine will clean, then flush 3 times in approximately 12 minutes (Fig. 3).

Fig. 3

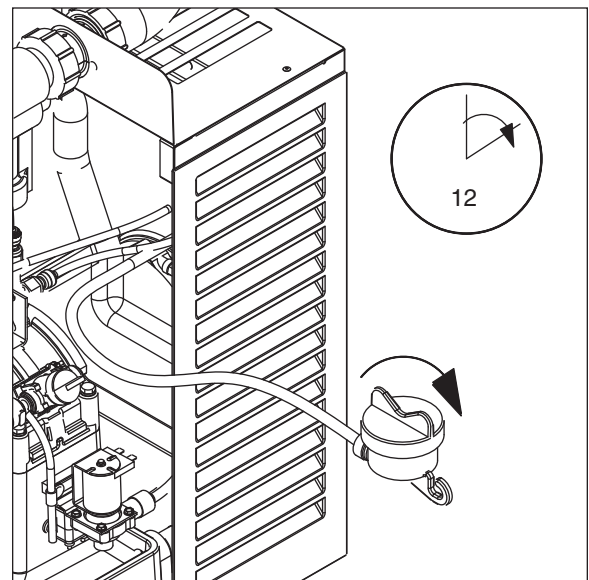

- To sanitize – Press CLEAN button. The machine will drain. Wait for LO WATER light to come on (Fig. 4).

Fig. 4

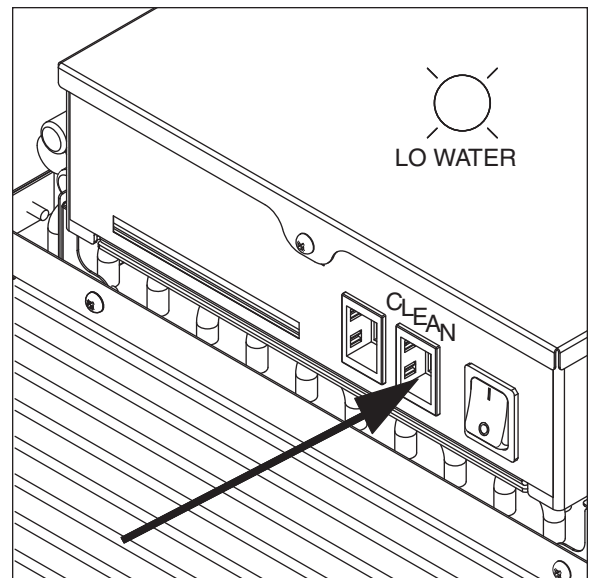

5. Mix 1 gallon 120°F (49°C) water and 1.6 ounces (48ml) NU-CALGON IMS-II SANITIZER. Fill until HI WATER light comes on (Fig. 5).

Note: Do not use bleach to sanitize or clean the icemaker.

Fig. 5

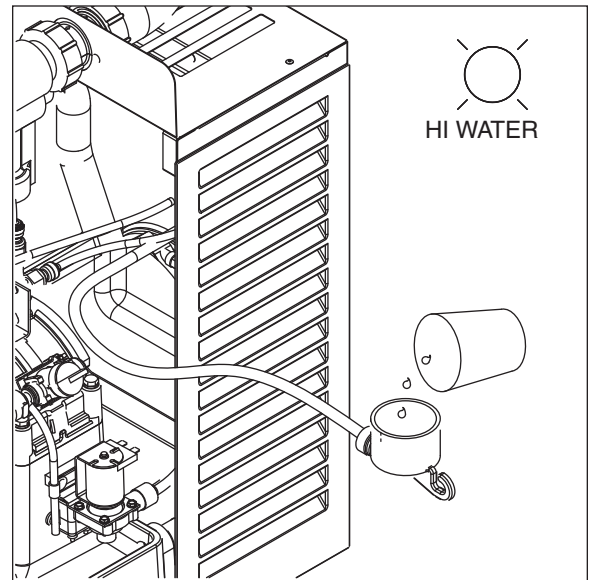

6. Replace cover on cleaning cup. Wait until machine restarts. Machine will sanitize, then flush 3 times in approximately 12 minutes (Fig. 6).

Fig. 6

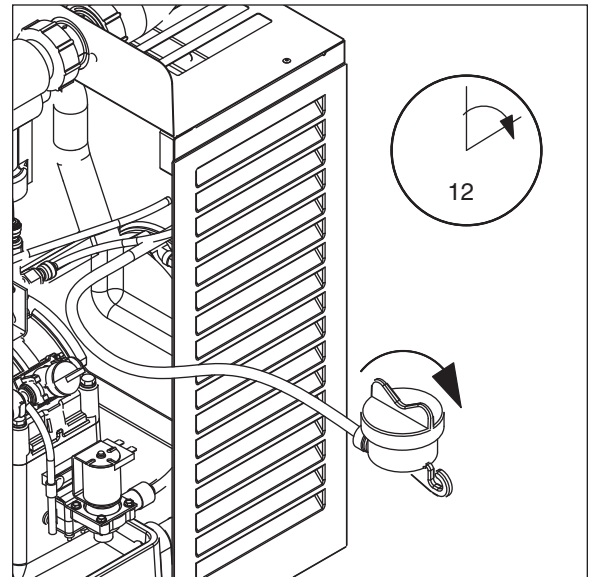

7. To clean transport tube – Press power switch OFF (Fig. 7).

Fig. 7

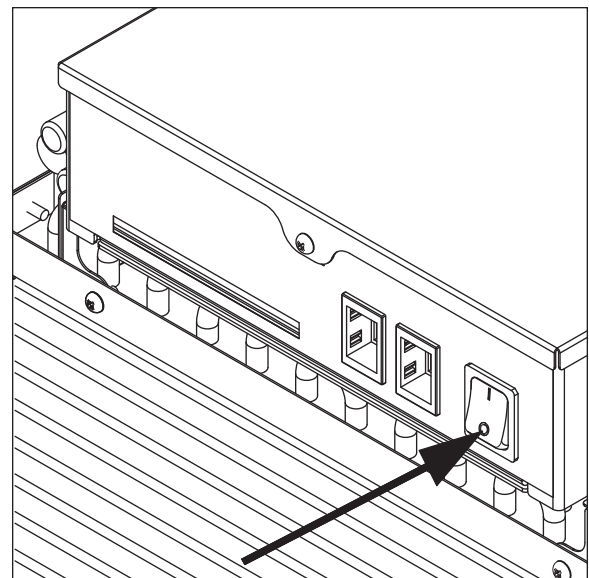

8. Disconnect coupling as shown (Fig. 8).

Fig. 8

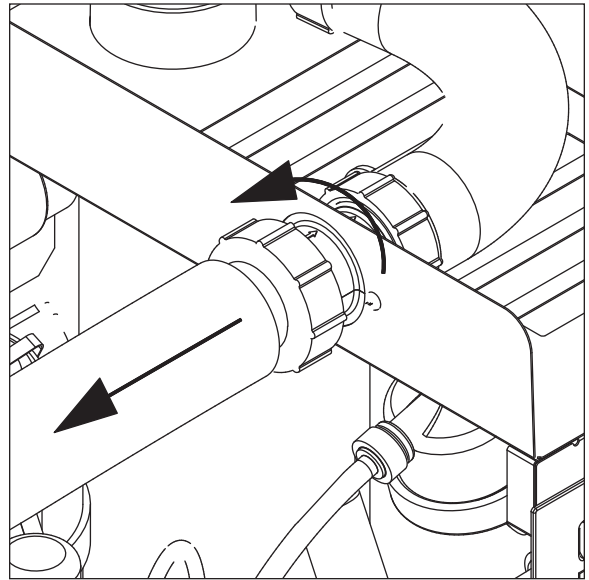

9. Using disposable food service grade gloves, insert dry Sani-Sponge™ (kit part# 00132068). Next, insert Sani-Sponge soaked in Nu-Calgon IMS-II sanitizer solution. Push both Sani-Sponges down ice transport tube with supplied pusher tube (Fig. 9).

Fig. 9

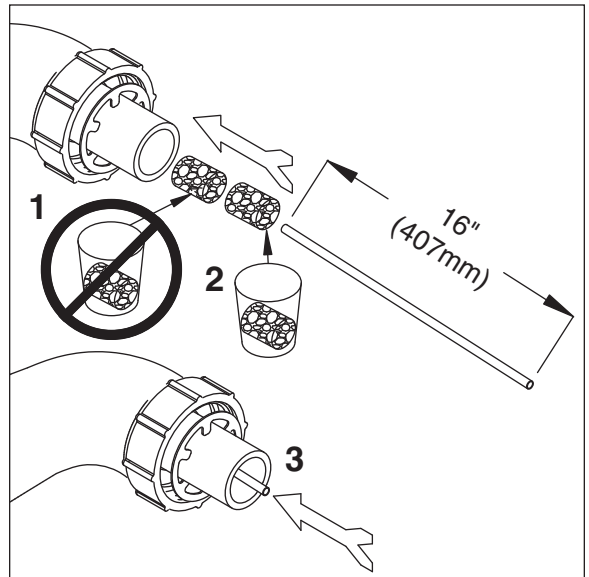

10. Remove and discard 16" (407mm) pusher tube (Fig. 10).

Fig. 10

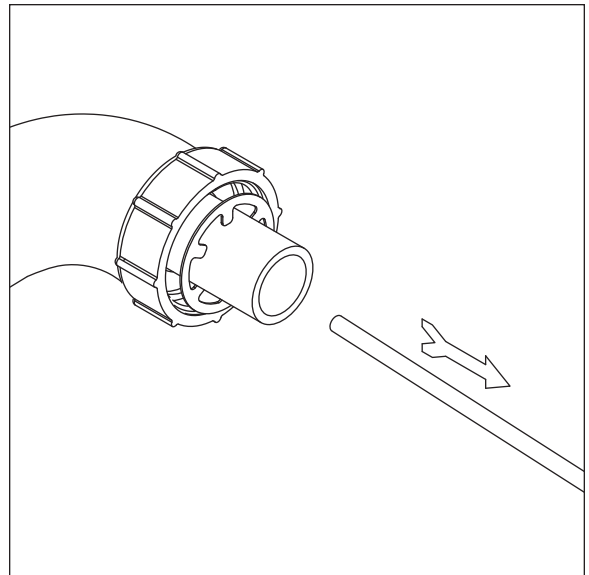

11. Reconnect coupling. Press power switch ON. Ice pushes Sani-Sponges through tube (Fig. 11).

Fig. 11

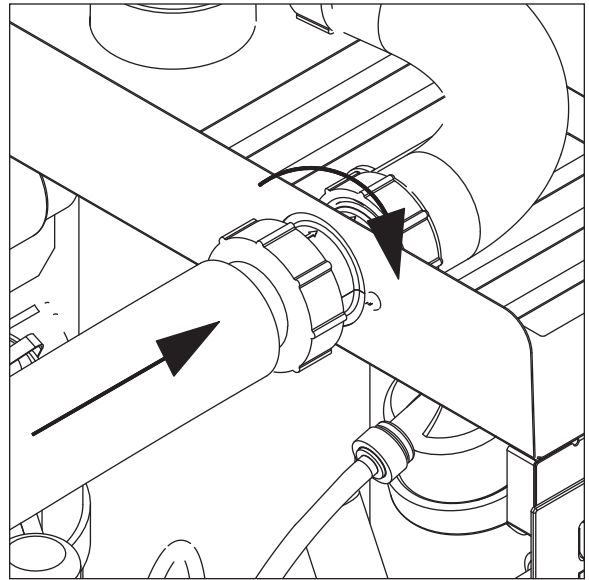

12. Place a sanitary (2 gallon or larger) container in bin or dispenser to collect Sani-Sponges and ice for 10 minutes. Collect 5.5 lbs of ice from unit. Discard ice and Sani-Sponges (Fig. 12).

Fig. 12

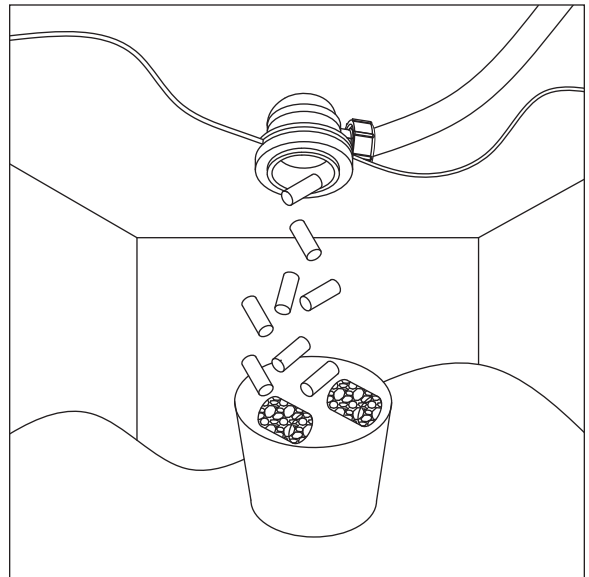

Service

Icemaker operation (all models)

Follett's icemaker consists of five distinct functional systems covered in detail as follows:

- Water system
- Electrical control system
- Mechanical assembly
- Refrigeration system
- Bin full

The Horizon icemaker overview

The Follett Horizon icemaker uses a horizontal, cylindrical evaporator to freeze water on its inner surface. The refrigeration cycle is continuous; there is no batch cycle. The evaporator is flooded with water and the level is controlled by sensors in a reservoir. A rotating auger (22 RPM) continuously scrapes ice from the inner wall of the evaporator. The auger moves harvested ice through the evaporator into an ice extrusion canal. The ice is forced through a restrictive nozzle that squeezes out the water and creates the Chewblet. The continuous extrusion process pushes the Chewblets through a transport tube into a dispenser or bin.

A solid state PC board controls and monitors the functionality of the ice machine. In addition to sequencing electrical components, the board monitors various operational parameters. A full complement of indicator lights allows visual status of the machine's operation. Additionally, the PC board controls the self-flushing feature of the icemaker. The evaporator water is periodically drained and replenished to remove minerals and sediment.

A unique "bin full" detection system is incorporated in the Horizon icemaker. A switch located at the ice discharge port of the machine detects the position of the transport tube. When the bin fills up with ice, the transport tube moves out of the normal running position, and the switch turns the ice maker off. A domed housing at the end of the transport tube contains the ice extrusion loads during shut down.

Harvest system diagram

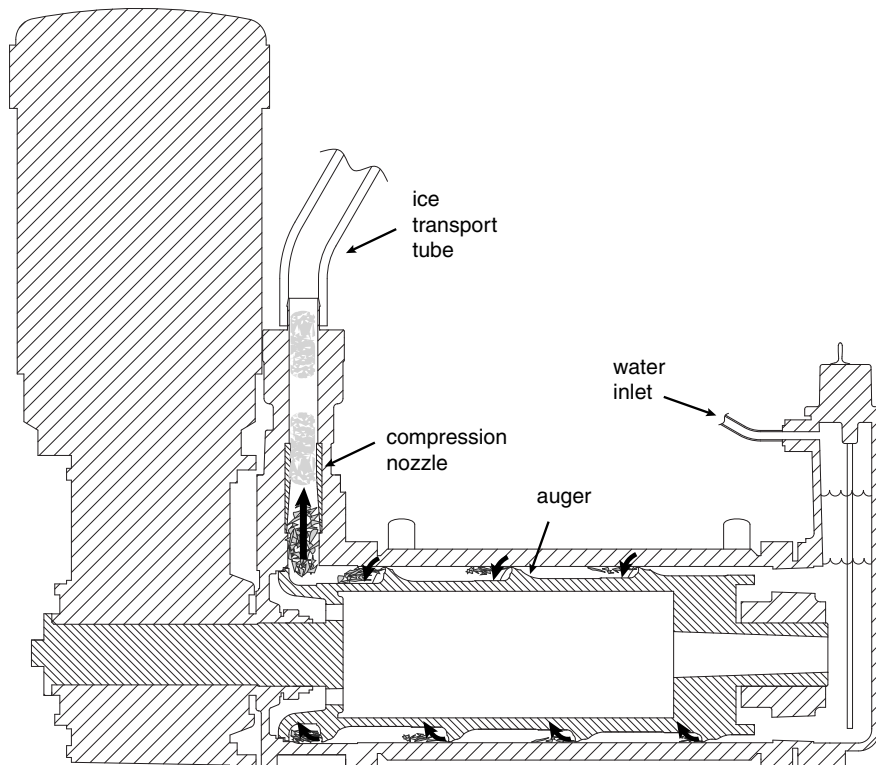

Water system

The water level in the evaporator is controlled by a feed solenoid and level detecting sensors. Referencing the diagram below, water sensing rods extend down into the reservoir at the end of the evaporator assembly. The system works via electrical conductivity as follows:

One of the longest probes is a common. When water is between any of the other probes and the common, the PC board will sense the activation. During normal operation, the water level rises and falls between the Normal High and Normal Low sensors. As water is consumed to make ice, the level will fall until the Normal Low sensor is exposed, triggering the water feed solenoid on. Water will fill until the Normal High sensor is activated.

Additional sensors are incorporated in the reservoir for alarm and cleaning/flushing conditions.

Note: The potable water dissolved solids content must be greater than 30 ppm for the water control system to function properly. If using reverse osmosis water filtration system, ensure T.D.S level is greater than 30 ppm.

Water system diagram

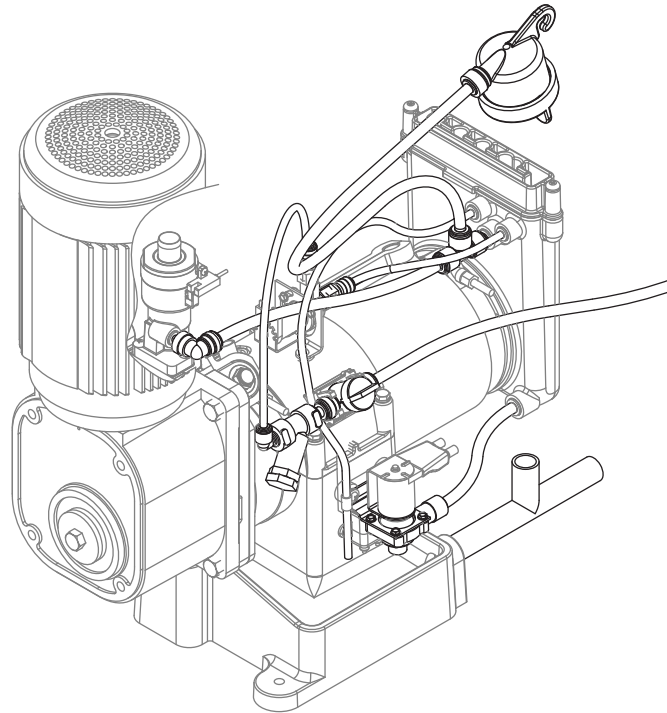

Water level diagram

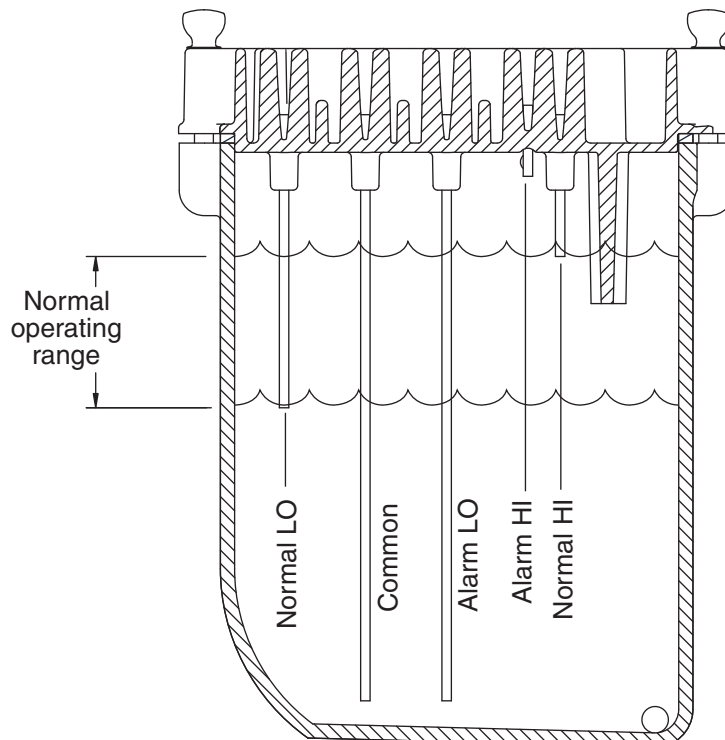

Electrical system

Normal control board operation

The PC board indicator lights provide all the information necessary to determine the machine's status. Green indicator lights generally represent "go" or normal operation; Yellow indicators represent normal off conditions; Red indicators generally represent alarm conditions, some of which will lock the machine off.

A green light labeled POWER indicates power to the machine. A flashing green light labeled CPU is normal and indicates that the Central Processing Unit "heart beat" is working. All other normal operation status indicators are covered as follows:

Ice machine disposition	Operating conditions
Legend: ● ON ○ OFF ◐ ON or OFF ✖ FLASHING	

1. Ice machine is making ice.



1. **Normal running.**

2. Ice machine is not making ice.



2. **Normal time delay.** When the bin fills with ice, the LOW BIN light goes out and the refrigeration and auger drive systems immediately shut down. The TIME DELAY light comes on, initiating the time delay period. When the time delay expires, the machine will restart provided that the LOW BIN light is on.

3. Ice machine is not making ice.



3. **Normal purge indicator.** After a selected period of ice making time has elapsed (2 or 6 hours), the ice machine will automatically self-flush. The refrigeration system will shut down but the gear motor will continue to run. After the flush is complete the machine will refill and start without a time delay.

Test points:

The Horizon PC board incorporates on-board test points that can be used to determine various electrical outputs. The test point holes allow a standard probe to be inserted for quick voltage measurement.

Time delay and self-flushing jumpers:

The duration of the Time Delay period, the time between normal shut down and restart, is jumper selectable. Jumpers J33 and J34 can be used to select a time delay value of either 1/2, 1, 2, or 3 hours. The factory default setting is 1 hour. Jumper J32 sets the self-flushing interval to 2 or 6 hours of compressor run time, and J31 either enables or disables self-flushing feature. The factory default setting is enabled flushing every 2 hours.

Error faults:

The Horizon PC board monitors various operating parameters including auger gearmotor amperage limits, clogged drain, and high and low water alarm conditions. There are two types of errors namely "hard" or "soft". A hard error is one that shuts the machine off and will not allow restart until the reset button is pressed. Even cycling power will not reset a hard error. A soft error can either be automatically reset should the condition rectify, or if power is cycled. Should an error occur, consult the troubleshooting guide in this manual or a Follett service technician. **Note:** there are two types of LO WATER and HI AMP errors as listed below.

Soft errors:

HI AMPS: The PC board monitors the amperage of the auger motor. Should the gear motor experience current draw above the 8.4 amps limit the machine will shut down and the TIME DELAY, HI AMP, and SERVICE LED's will be illuminated. After the time delay the machine will restart and the TIME DELAY, HI AMP, and SERVICE LED's will clear.

HI WATER: A sensor in the water reservoir is positioned at the very top of the reservoir cap. Should water rise to this high alarm sensor, a soft error will occur. The machine will operate with this alarm active, however the water feed solenoid will not be on. The alarm will turn off should water recede from the sensor.

LO WATER: During operation, the water level cycles between the normal low and normal high sensors. Should the water be shut off to a running machine, a soft error will occur. The error sequence is as follows: During operation, the water level falls to the normal low sensor, and when it does the water feed solenoid is energized. If water is not detected at the normal low sensor within 120 seconds, a soft error will occur. The machine will shut down, but the water feed solenoid will remain energized. Should water return, it will fill to the normal low sensor and the machine will resume normal operation. The error will clear automatically.

Hard errors:

HI AMPS:

1. "Two strikes" feature. If the gearmotor has a second HI AMP occurrence during the countdown period (6 hours after a HI AMP time delay) a hard error will occur and the HI AMP and SERVICE LED's will be illuminated.
2. No current. To prevent the refrigeration system from running without gearmotor rotation the PC board will indicate HIGH AMP and SERVICE if the drive relay is energized and there is no current draw.

DRAIN CLOG: The drain clog sensor, located in the plastic drain pan behind the drain solenoid, will detect the presence of water just below the top edge of the pan. If water does not properly flow out of the drain pan it will rise to the sensor, especially during a self-flushing purge cycle.

LO WATER:

1. There is a sensor in the water reservoir that reaches down to the very bottom. The machine will not start if water is not present at this sensor.
2. A hard error will occur should water not be present within 60 seconds of power up or if the sensors are disconnected or damaged.

Relay output indication:

Each relay on the board has an indicator light associated with its output. For example, when the relay for the water feed solenoid is energized, the adjacent indicator light glows green.

Comp/Sol output:

The COMP/SOL output is wired to the liquid line solenoid valve.

Wiring diagram, evaporator unit

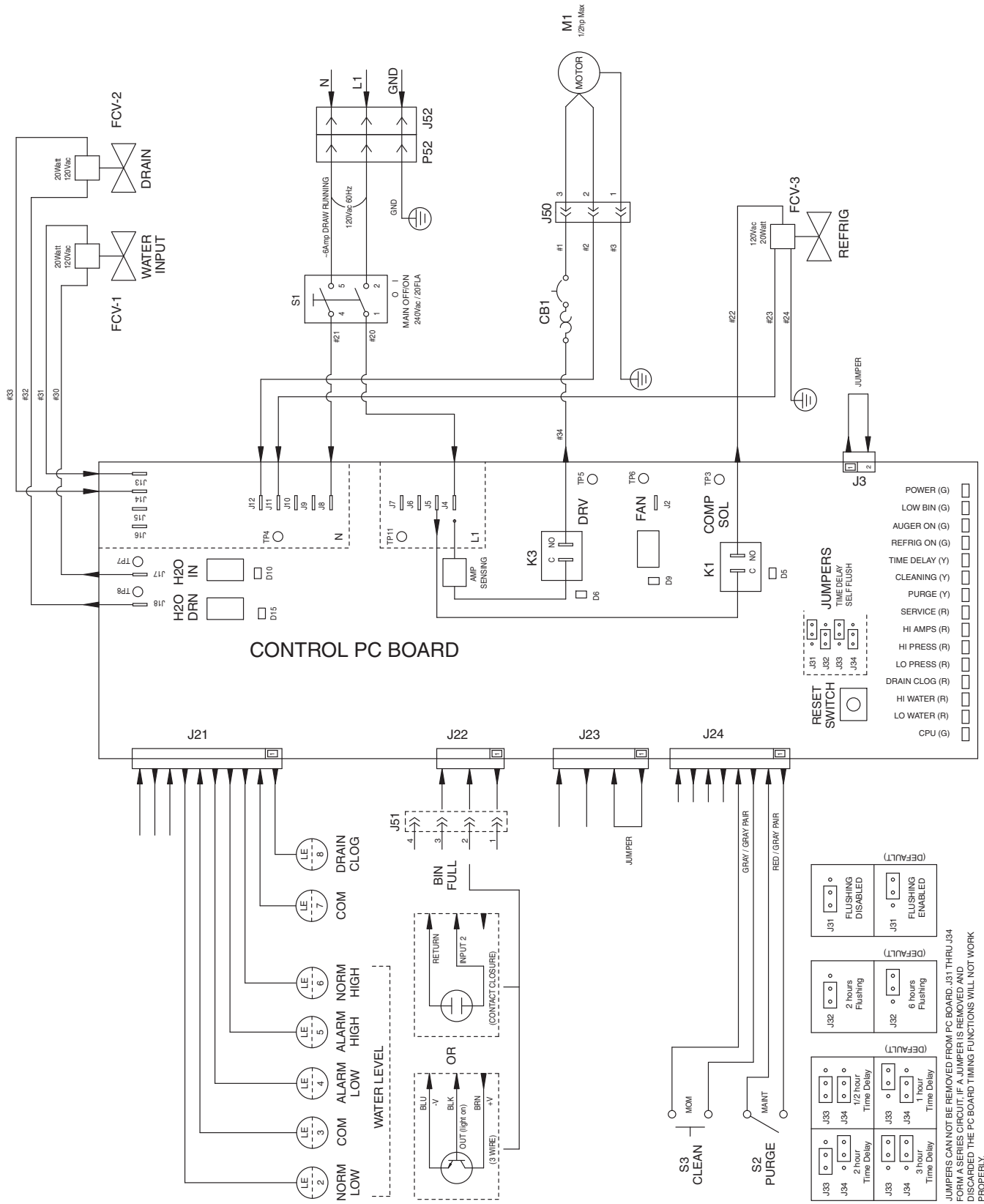

JUMPERS CAN NOT BE REMOVED FROM PC BOARD. J31 THRU J34 FORM A SERIES CIRCUIT. IF A JUMPER IS REMOVED AND DISCARDED THE PC BOARD TIMING FUNCTIONS WILL NOT WORK PROPERLY.

Wiring diagram, condenser unit

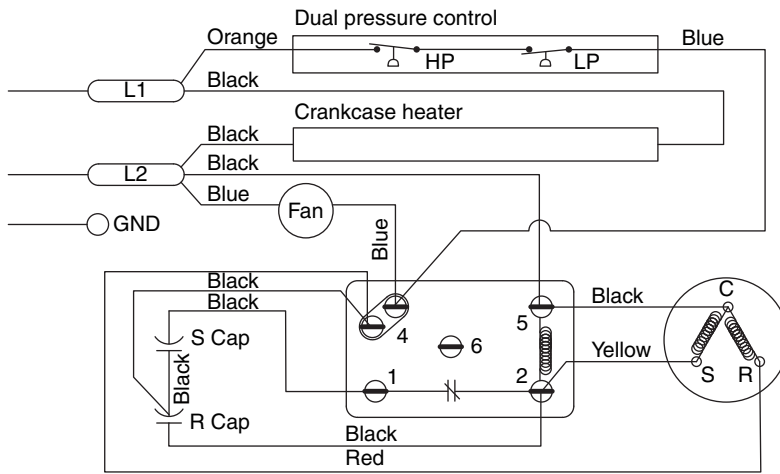

Gearmotor data

	Brother
Gearmotor current	5.0A (nominal)
Locked rotor amps	15 amps

Resistance of windings

115 vac gearmotor (Brother)	1.7Ω
-----------------------------	------

Mechanical system

Evaporator disassembly

1. Press PURGE button to purge evaporator, and then turn power OFF.
2. Unscrew and remove stream divider as shown.

Fig. 13

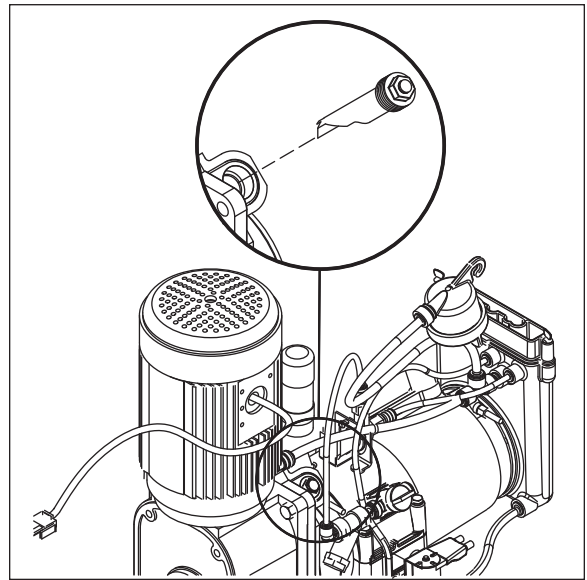

3. Unplug and remove gearmotor as shown.
4. Remove all traces of anti-seize compound or petrol-gel from the auger shaft.

Fig. 14

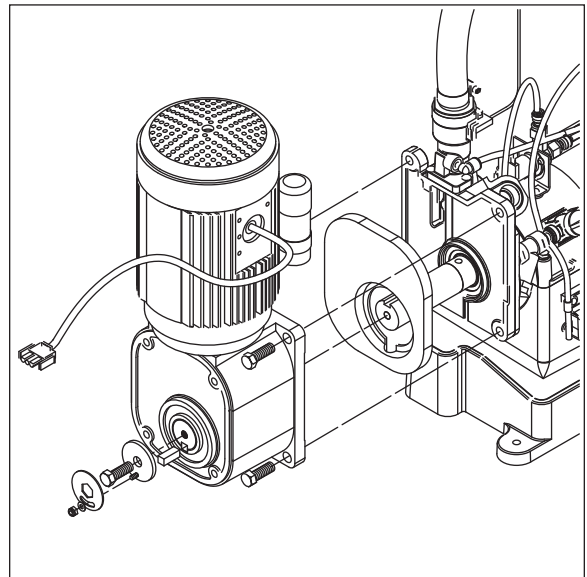

5. Unscrew and disconnect transport tube from louvered docking assembly.
6. Unplug sensor at the electrical box.
7. Remove vent tube from shuttle housing as shown.

Fig. 15

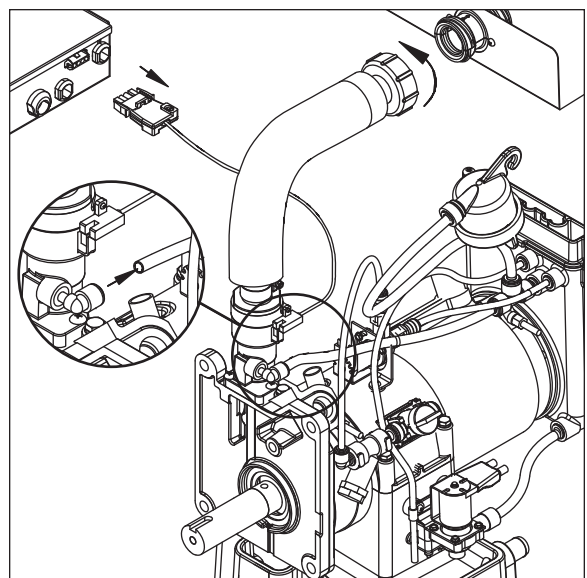

8. Loosen nut on V-band clamp and remove.
9. Remove V-band clamp from front of evaporator.
10. Remove main housing as shown.

Fig. 16

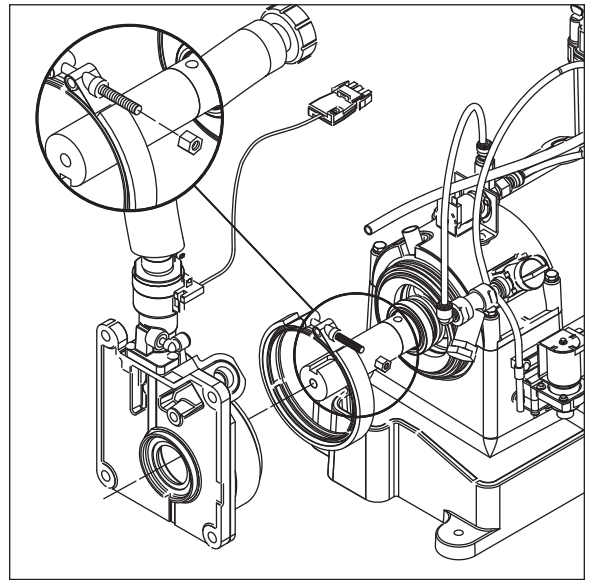

11. Remove and discard mating ring and seal.
12. Carefully remove auger.

Fig. 17

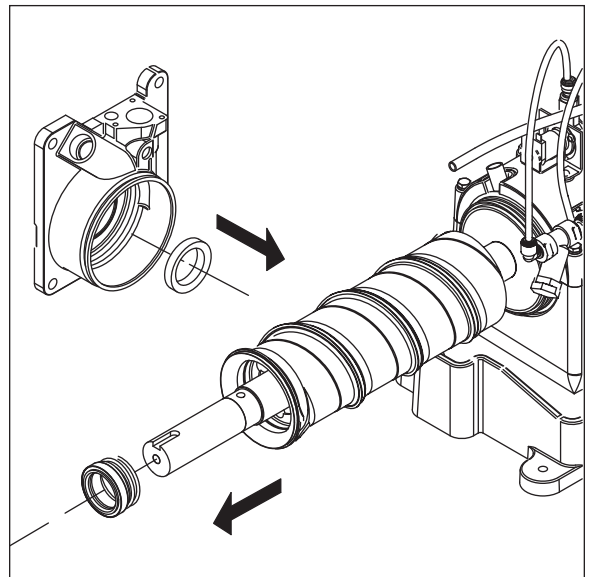

Evaporator reassembly

1. Remove and inspect O ring seal. Discard if damaged in any way.
2. Clean O ring groove. Lubricate O ring with petrol-gel and reinstall.

Fig. 18

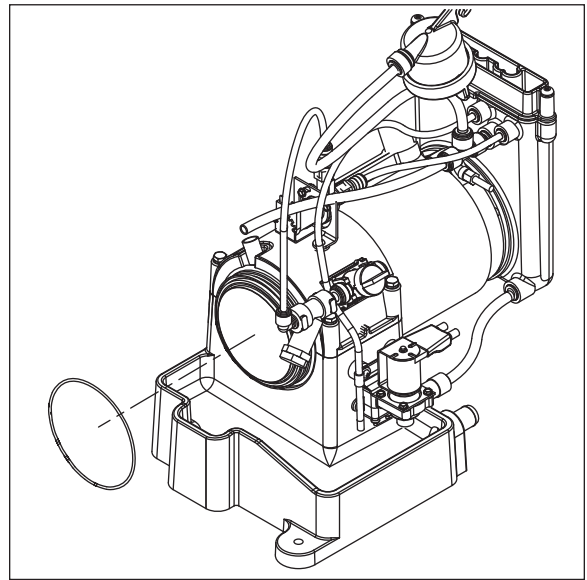

3. Press new mating ring into main housing as shown.
4. Lube the shaft with liquid soap in the area shown and slip on seal and spring.

Note: Do not touch the sealing surfaces. Use cardboard disk to install.

Fig. 19

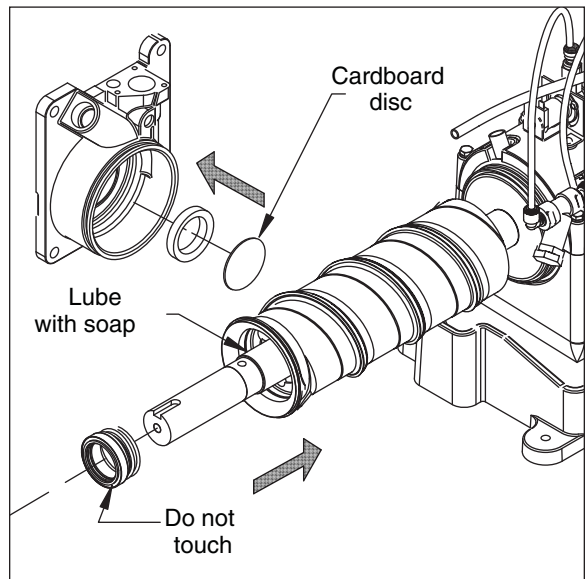

5. Reinstall main housing as shown.

Fig. 20

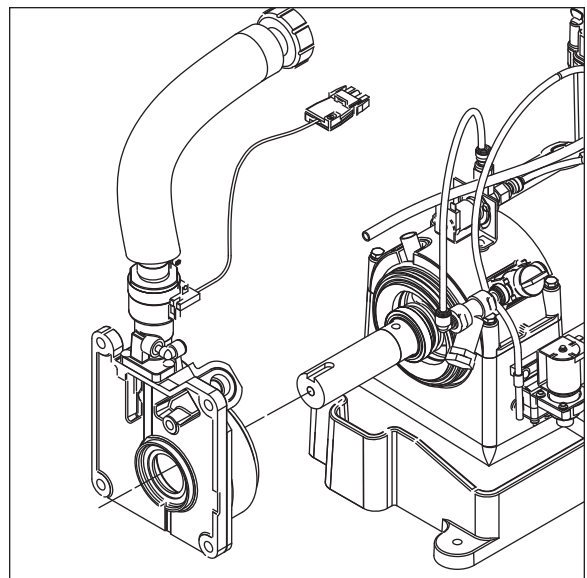

6. Orient auger shaft with keyway in the upward position.
7. Force main housing into position against evaporator and place 1/4" (7mm) diameter Phillips screwdriver into hole in the auger shaft.
8. Replace V-band clamp as shown.
9. Replace nut on V-band clamp and tighten.
10. Remove screwdriver.

Fig. 21

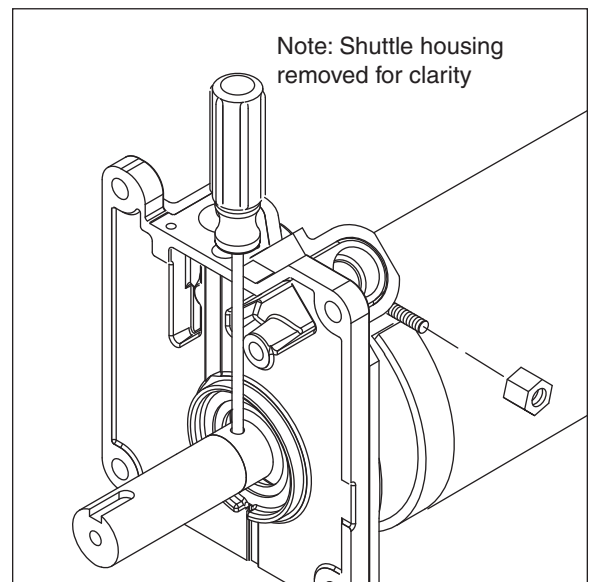

11. Reconnect transport tube to louvered docking assembly.
12. Plug sensor in at the electrical box.
13. Reconnect vent tube to the shuttle housing as shown.

Fig. 22

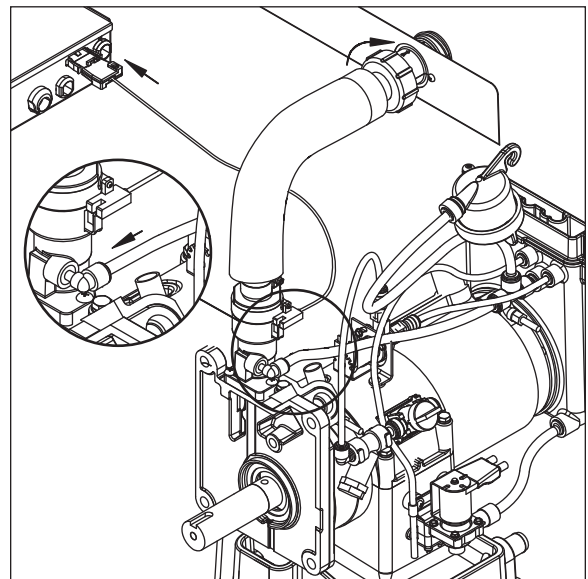

14. Apply a coat of petrol-gel to the auger shaft.
15. Install gearmotor, making sure that insulation is properly seated between gearmotor and main housing as shown.
16. Firmly tighten four gearmotor bolts in place.
17. Insert a bolt into the auger shaft and finger tighten.

Fig. 23

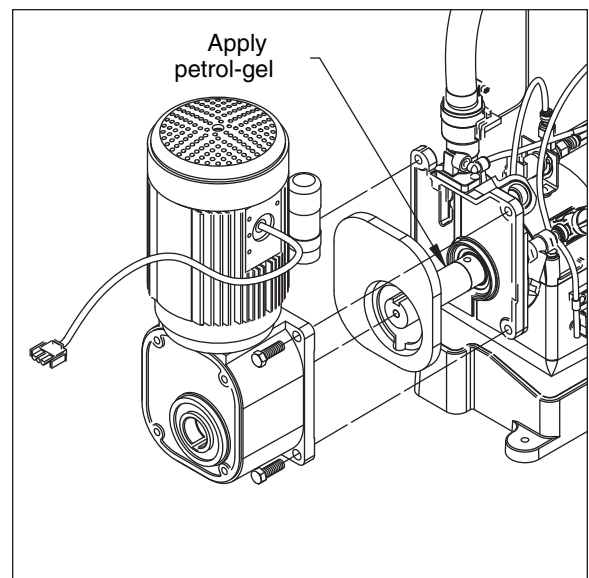

18. Using a wrench, rotate the shaft clockwise to align the keyways in the gear housing and the shaft so as to accept the key.
19. Insert the key into the keyway.

Fig. 24

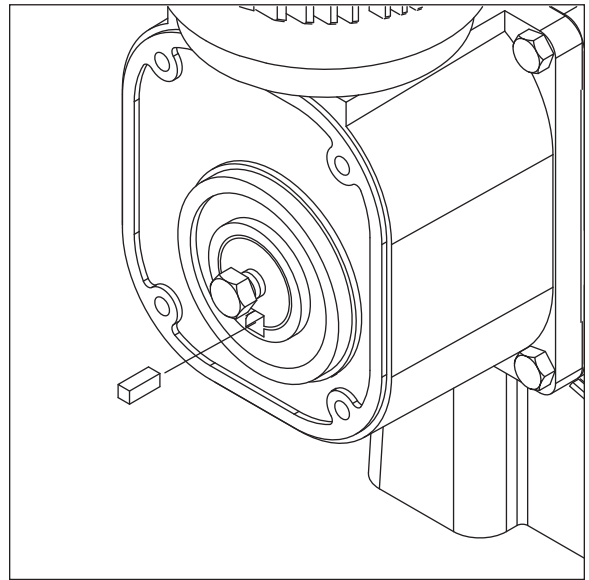

20. Remove bolt and reinstall the washer and bolt. Place retainer over bolt and secure with nut and washer.

Fig. 25

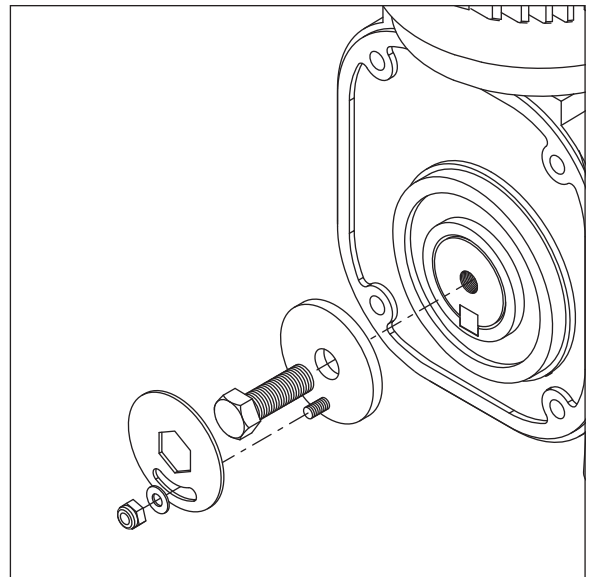

21. Lubricate body of stream divider with petrol-gel and reinstall.
22. Plug gearmotor power cord into electrical box.

Fig. 26

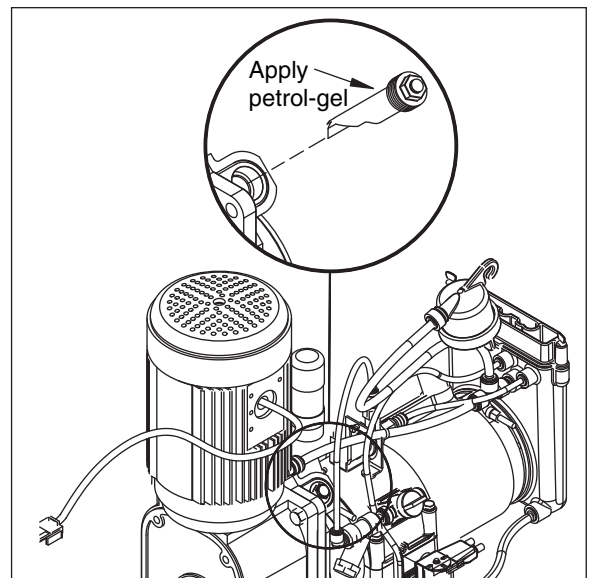

Refrigeration system

Condenser unit operation

The condensing unit is weatherproof and equipped to operate in ambient temperatures from $-20^{\circ}\text{F} - 120^{\circ}\text{F}$ ($-29^{\circ}\text{C} - 48.9^{\circ}\text{C}$). The condensing unit is controlled by a dual pressure control, which works in concert with a refrigerant solenoid valve on the evaporator module. On start-up, the refrigerant solenoid valve opens and suction pressure rises above the “on” set point of the control (30 psi). The compressor and fan turn on and the refrigeration system operates. Upon shut down, the refrigerant solenoid closes. The compressor will pump down the suction line until the low “off” set point is reached (10 psi), at which point the compressor and fan will turn off.

Low ambient operation: Reliable operation at low ambient temperature is achieved with a pumpdown cycle, a crankcase heater and a head pressure control valve. As the ambient temperature falls and the head pressure decreases the valve maintains a minimum head pressure of 180 psi by bypassing discharge gas around the condenser to the receiver to increase the pressure at the condenser outlet. This backs liquid refrigerant up in the condenser to reduce the area available for condensing which increases the head pressure to maintain the 180 psi set point. A check valve is installed in the liquid line between the receiver and the condenser to prevent liquid migration from the receiver to the condenser during the off cycle. The crankcase heater works in conjunction with a continuous pumpdown cycle to prevent accumulation of liquid refrigerant in the compressor oil during the off cycle. This prevents compressor damage due to a flooded compressor start. The low pressure control will start the condensing unit anytime the low side pressure rises above the 30 psi set point and pump the refrigerant out until the pressure falls to 10 psi. The crankcase heater, which is energized whenever the condensing unit has power, keeps the compressor oil warmer than the coldest location in the system. This minimizes off cycle refrigerant migration. If power to the condensing unit is interrupted after the system is charged the compressor should not be started unless the crankcase heater has been energized for at least four hours immediately prior to compressor startup. However the compressor can safely be started during the refrigeration system charging process (without the warm-up period) once sufficient refrigerant is in the system to maintain a positive pressure on the suction side of the compressor.

Refrigerant pressure data

Air-cooled condensers (air)	60°F/16°C	70°F/21°C	80°F/27°C	90°F/32°C	100°F/38°C
Pressure (psig) discharge/suction	224/31	232/32	240/33	277/36	313/38

Refrigerant charges

R404A icemaker charge specifications		
Model	Line Run	Charge
1000	0 – 50 ft (0 – 15.2m)	8 lbs (3.6kg)
	50 – 75 ft (15.2 – 22.9m)	9 lbs (4.1kg)
	75 – 100 ft (22.9 – 30.5m)	10 lbs (4.5kg)
	100 ft+ (30.5m+)	Consult factory

Refrigeration system diagram

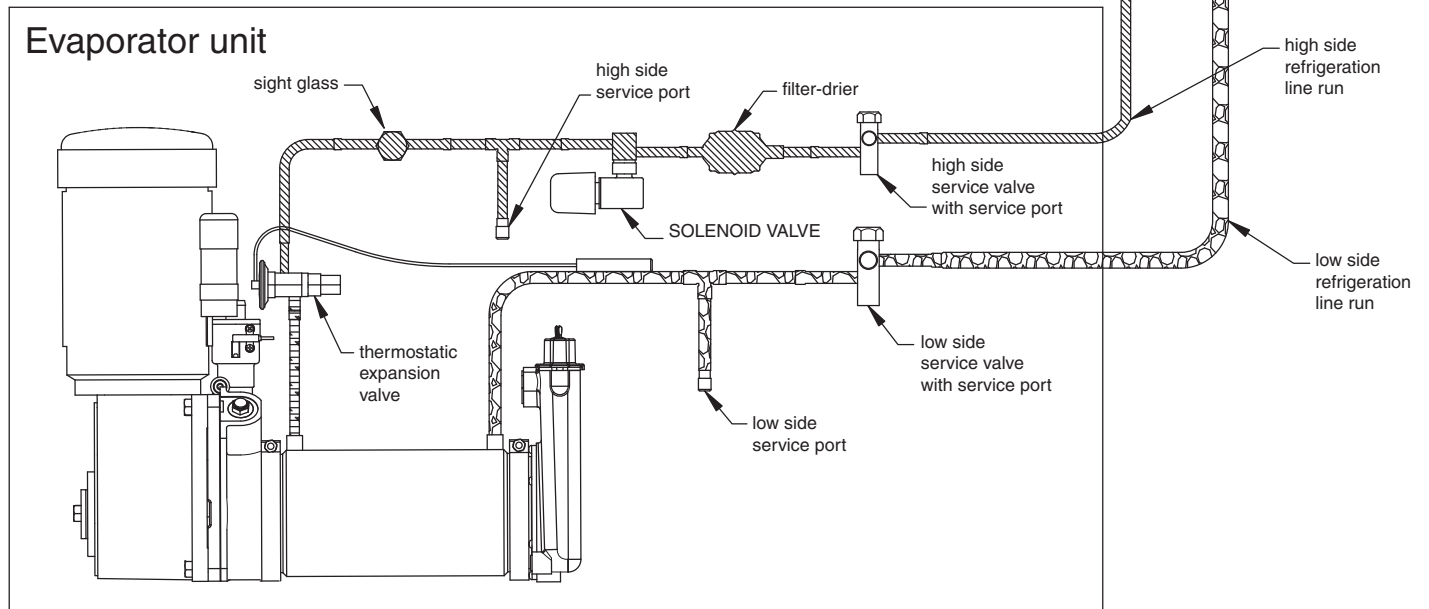
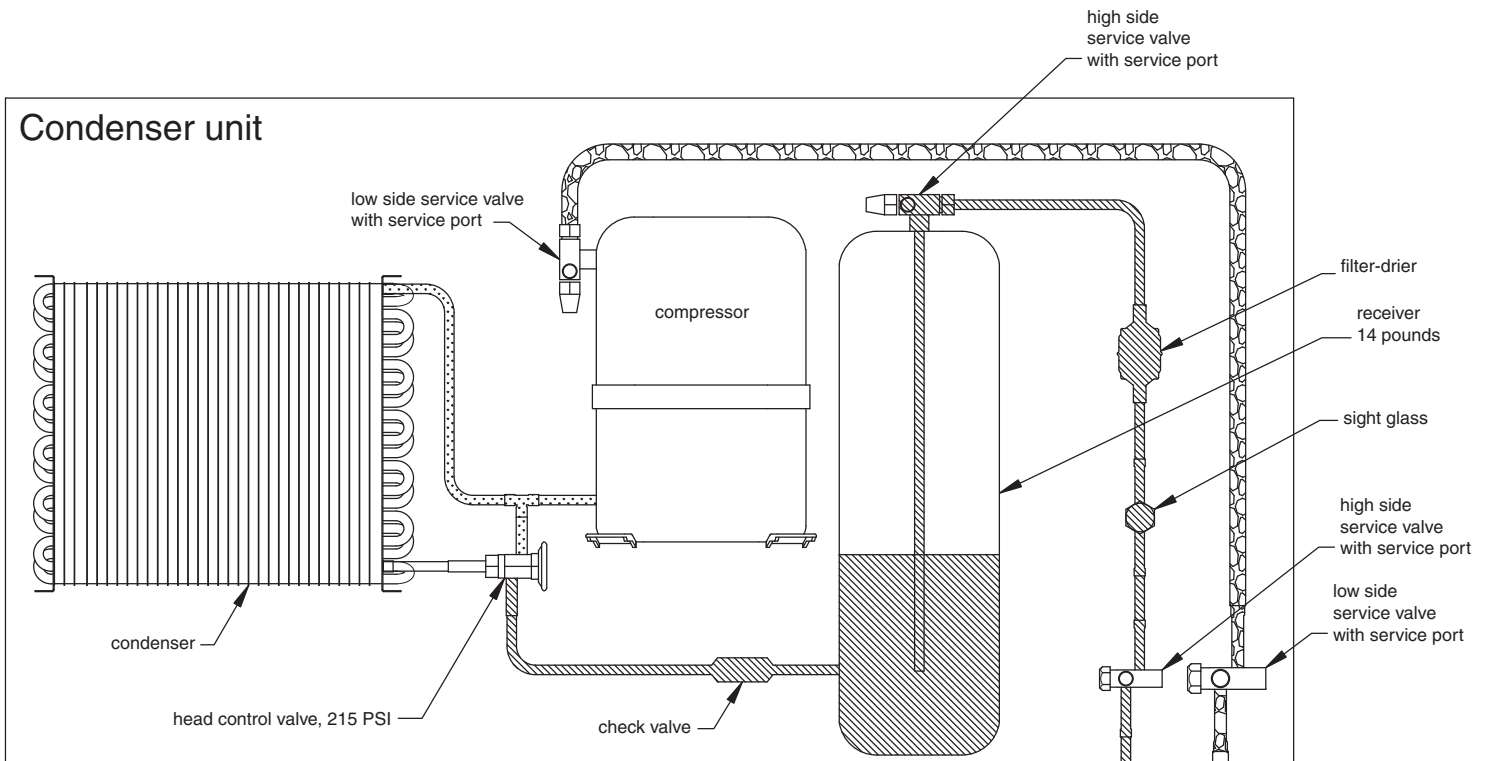

High pressure vapor



High pressure liquid

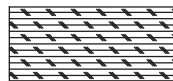

Low pressure liquid

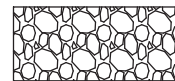

Low pressure vapor

Refrigerant replacement requirements

1. Non-contaminated refrigerant removed from any Follett refrigeration system can be recycled and returned to the same system after completing repairs. Recycled refrigerant must be stored in a clean, approved storage container. If additional refrigerant is required, virgin or reclaimed refrigerant that meets ARI standard 700-88 must be used.
2. In the event of system contamination (for example, a compressor burn out, refrigerant leak, presence of non-condensibles or moisture), the system must be repaired, evacuated and recharged using virgin or reclaimed refrigerant that meets ARI standard 700-88.
3. Follett Corporation does not approve of recovered refrigerants. Improper refrigeration servicing procedures will void the factory warranty.

Evacuation

Evacuate the system to a level of 500 microns. When the 500 micron level is reached, close valves and both manifold and shut down the vacuum pump. Allow the system to sit for approximately 20 minutes. During this period the system pressure should not rise. If the system pressure rises and stabilizes there is moisture in the system and further evacuation is needed. If the pressure continues to rise check the system for leaks.

Ambients (evaporator unit)

Air temperature¹

Minimum

50°F/10°C

Maximum

100°F/37.8°C

Water temperature²

45°F/7°C

90°F/32.2°C

¹Ambient air temperature is measured at the air-cooled condenser coil inlet.

²Ambient water temperature is measured in the icemaker float reservoir.

Ice capacity test

Icemaker production capacity can only be determined by weighing ice produced in a specific time period.

1. Replace all panels on icemaker.
2. Run icemaker for at least 15 minutes.
3. Weigh and record weight of container used to catch ice.
4. Catch ice for 15 or 20 minutes.
5. Weigh harvested ice and record total weight.
6. Subtract weight of container from total weight.
7. Convert fractions of pounds to decimal equivalents (ex. 6 lbs 8oz = 6.5 lbs).
8. Calculate production using following formula:

$$\frac{1440 \text{ min.} \times \text{wt. of ice produced}}{\text{Total test time in minutes}} = \text{Production capacity/24 hr. period}$$

9. Calculated amount per 24 hours should be checked against rated capacity for same ambient and water temperatures in Ice Production Tables.

“Bin full” detection system

The Follett Horizon icemaker incorporates a unique “bin full” detection system, that consists of the shuttle and actuator. The shuttle incorporates a flag and sensor. Referencing the figure below, the normal running position of the flag is down, out of the sensor. When the bin fills to the top and ice can no longer move through the tube, the machine will force the shuttle flag up into the sensor, shutting the machine off. The shuttle actuator, located above the ice bin allows the ice to curl up within it when the bin is full to contain any forces. In this way, there are no loads generated that would tend to lift off the lid of the bin.

Shuttle flag and sensor

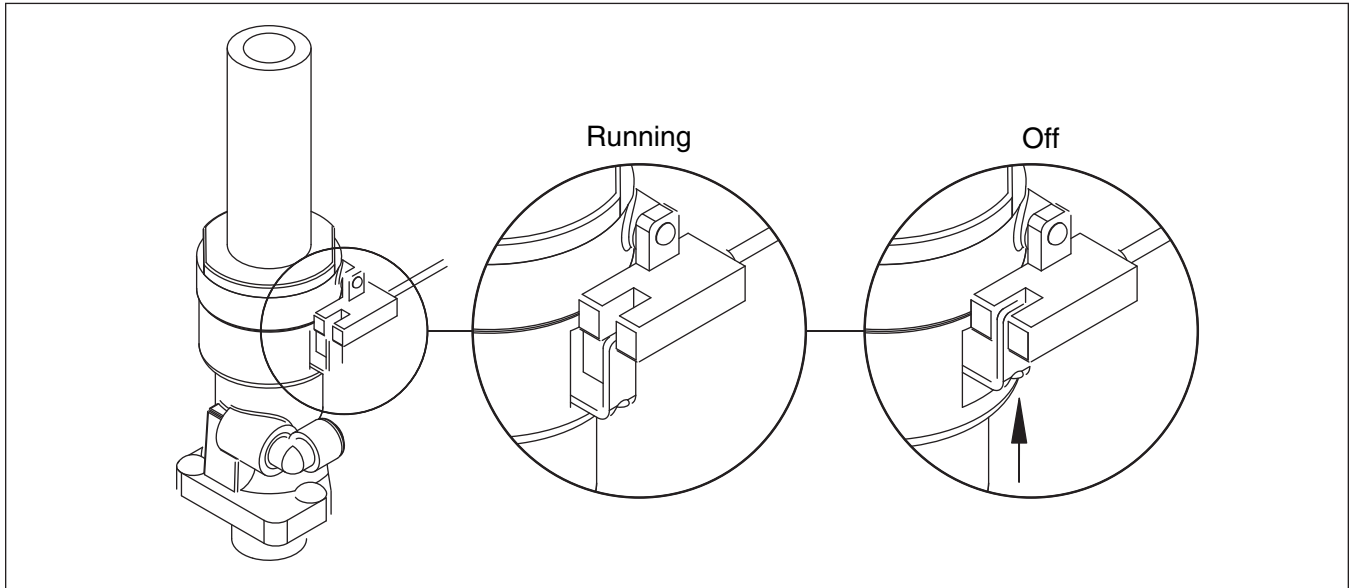

Shuttle actuator

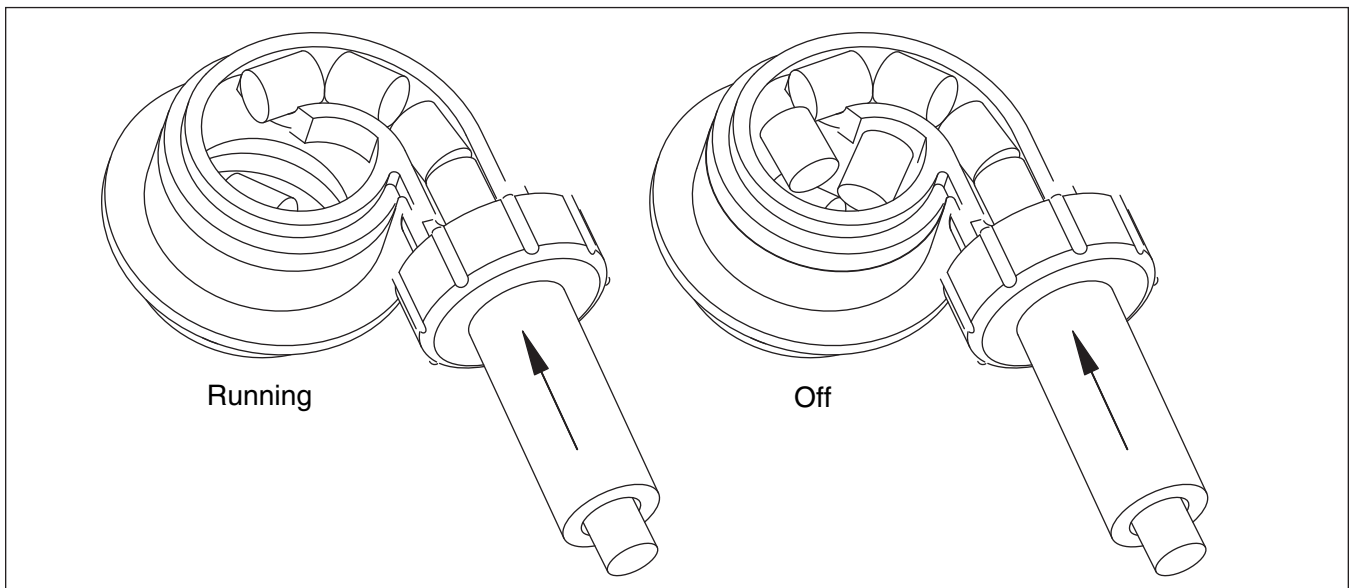

Troubleshooting

Please see "Service" section for a description of each function.

Ice machine disposition	Possible Causes	Corrective Actions
Legend: ● ON ○ OFF ◐ ON or OFF ✖ FLASHING		
1. Ice machine is in running condition but not making ice. CPU <input checked="" type="radio"/> LO WATER <input type="radio"/> HI WATER <input type="radio"/> DRAIN CLOG <input type="radio"/> HI AMPS <input type="radio"/> SERVICE <input type="radio"/> PURGE <input type="radio"/> CLEANING <input type="radio"/> TIME DELAY <input type="radio"/> REFRIG ON <input type="radio"/> AUGER ON <input type="radio"/> LOW BIN <input type="radio"/> POWER <input type="radio"/>	1. Defective compressor. 2. Defective start relay. 3. Defective start capacitor. 4. Defective run capacitor. 5. Defective main contactor. 6. No output from PC board.	1. Replace compressor. 2. Replace start relay. 3. Replace start capacitor. 4. Replace run capacitor. 5. Replace main contactor. 6. Replace PC board.
2. The CPU is not flashing. CPU <input type="radio"/> LO WATER <input type="radio"/> HI WATER <input type="radio"/> DRAIN CLOG <input type="radio"/> HI AMPS <input type="radio"/> SERVICE <input type="radio"/> PURGE <input type="radio"/> CLEANING <input type="radio"/> TIME DELAY <input type="radio"/> REFRIG ON <input type="radio"/> AUGER ON <input type="radio"/> LOW BIN <input type="radio"/> POWER <input type="radio"/>	1. Processor has been damaged.	1. Replace PC board.
3. Machine in TIME DELAY without full bin. CPU <input checked="" type="radio"/> LO WATER <input type="radio"/> HI WATER <input type="radio"/> DRAIN CLOG <input type="radio"/> HI AMPS <input type="radio"/> SERVICE <input type="radio"/> PURGE <input type="radio"/> CLEANING <input type="radio"/> TIME DELAY <input type="radio"/> REFRIG ON <input type="radio"/> AUGER ON <input type="radio"/> LOW BIN <input type="radio"/> POWER <input type="radio"/>	1. Ice jamming due to improperly installed transport tube causing a false shuttle. 2. Shuttle stuck in up position. 3. Damaged or improperly installed thermostat (open). 4. Transport tube backed-out of coupling.	1. Correct transport tube routing. Install anti-kink elbows (#00136358) at bends in transport tube. 2. Repair or replace shuttle mechanism. 3. Replace or reposition thermostat. 4. Correct coupling installation with new star washer.
4. Ice machine is not making ice. Locked in PURGE. CPU <input checked="" type="radio"/> LO WATER <input type="radio"/> HI WATER <input type="radio"/> DRAIN CLOG <input type="radio"/> HI AMPS <input type="radio"/> SERVICE <input type="radio"/> PURGE <input checked="" type="radio"/> CLEANING <input type="radio"/> TIME DELAY <input type="radio"/> REFRIG ON <input type="radio"/> AUGER ON <input type="radio"/> LOW BIN <input type="radio"/> POWER <input type="radio"/>	1. A self-flush occurred but could not drain evaporator due to a failed drain solenoid valve. 2. A self-flush occurred but could not drain evaporator due to water reservoir or ice machine not being level.	1. Replace drain solenoid valve. 2. Level ice machine. Check water reservoir to make sure it is not tilted towards the compressor.
5. Ice machine is not making ice. HI AMPS. CPU <input checked="" type="radio"/> LO WATER <input type="radio"/> HI WATER <input type="radio"/> DRAIN CLOG <input type="radio"/> HI AMPS <input checked="" type="radio"/> SERVICE <input type="radio"/> PURGE <input type="radio"/> CLEANING <input type="radio"/> TIME DELAY <input type="radio"/> REFRIG ON <input type="radio"/> AUGER ON <input type="radio"/> LOW BIN <input type="radio"/> POWER <input type="radio"/>	1. Poor water quality causing ice to jam auger. 2. Damaged shuttle mechanism or thermostat (closed). 3. Kinked transport tube (thermostat systems). 4. Intermittent drive output from PC board. Evaporator will freeze causing a hi amps error. 5. Gearmotor is unplugged.	1. Clean ice machine. Increase flushing frequency. 2. Replace or repair shuttle mechanism/thermostat. 3. Install anti-kink elbows (#00136358) at bends in transport tube. 4. Replace PC board.
5. Plug in gearmotor. <i>(see page 15 for "no current" details)</i>		

Ice machine disposition	Possible causes	Corrective actions
Legend: ● ON ○ OFF ◐ ON or OFF ✖ FLASHING		
<p>6. Ice machine is not making ice. Drain clog.</p> <p> CPU <input checked="" type="radio"/> ○ ○ ○ LO WATER ○ ○ ○ ○ HI WATER ○ ○ ○ ○ DRAIN CLOG ○ ○ ○ ○ </p> <p> HI AMPS ○ ○ ○ ○ SERVICE ● ○ ○ ○ PURGE ○ ○ ○ ○ CLEANING ○ ○ ○ ○ TIME DELAY ○ ○ ○ ○ REFRIG ON ○ ○ ○ ○ AUGER ON ○ ○ ○ ○ LOW BIN ○ ○ ○ ○ POWER ● ○ ○ ○ </p>	<ol style="list-style-type: none"> 1. Drain hose kinked or plugged causing water to back up. 2. Improper floor drain routing/pitch causing water to back up. 3. High TDS levels and leaking drain solenoid may cause an errant drain clog. 4. No vent in drain line causing backup during a purge. 	<ol style="list-style-type: none"> 1. Remove kink or blockage from drain hose. 2. Re-route floor drain. 3. Clean area around drain sensor and/or replace Drain solenoid valve. 4. Add vent to drain line.
<p>7. Ice machine is making ice. Excessive water in bin or coming into bin from transport tube.</p> <p> CPU <input checked="" type="radio"/> ○ ○ ○ LO WATER ○ ○ ○ ● HI WATER ○ ○ ○ ○ DRAIN CLOG ○ ○ ○ ○ </p> <p> HI AMPS ○ ○ ○ ○ SERVICE ● ○ ○ ○ PURGE ○ ○ ○ ○ CLEANING ○ ○ ○ ○ TIME DELAY ○ ○ ○ ○ REFRIG ON ○ ○ ○ ○ AUGER ON ○ ○ ○ ○ LOW BIN ○ ○ ○ ○ POWER ● ○ ○ ○ </p>	<ol style="list-style-type: none"> 1. Defective water feed solenoid valve. Stuck in open position. 	<ol style="list-style-type: none"> 1. Replace water feed solenoid valve.
<p>8. Ice machine is making ice. Excessive water in bin or coming into bin from transport tube.</p> <p> CPU <input checked="" type="radio"/> ○ ○ ○ LO WATER ○ ○ ○ ● HI WATER ○ ○ ○ ○ DRAIN CLOG ○ ○ ○ ○ </p> <p> HI AMPS ○ ○ ○ ○ SERVICE ● ○ ○ ○ PURGE ○ ○ ○ ○ CLEANING ○ ○ ○ ○ TIME DELAY ○ ○ ○ ○ REFRIG ON ○ ○ ○ ○ AUGER ON ○ ○ ○ ○ LOW BIN ○ ○ ○ ○ POWER ● ○ ○ ○ </p>	<ol style="list-style-type: none"> 1. Failed water sensors. Processor assumes there is no water when there is water. 2. Blocked reservoir vent. 	<ol style="list-style-type: none"> 1. Clean or replace water probe assembly. Check wiring connections. 2. Clean or replace vent tubes.
<p>9. Ice machine is not making ice. Lo water.</p> <p> CPU <input checked="" type="radio"/> ○ ○ ○ LO WATER ○ ○ ○ ○ HI WATER ○ ○ ○ ○ DRAIN CLOG ○ ○ ○ ○ </p> <p> HI AMPS ○ ○ ○ ○ SERVICE ○ ○ ○ ○ PURGE ○ ○ ○ ○ CLEANING ○ ○ ○ ○ TIME DELAY ○ ○ ○ ○ REFRIG ON ○ ○ ○ ○ AUGER ON ○ ○ ○ ○ LOW BIN ○ ○ ○ ○ POWER ● ○ ○ ○ </p>	<ol style="list-style-type: none"> 1. Water supply is turned off. 2. Low water pressure. 3. Defective water feed solenoid valve. Stuck in closed position. 4. No water feed output from PC board. 	<ol style="list-style-type: none"> 1. Turn water supply on. If evaporator was completely empty, the reset button may have to be pressed to restart the ice machine. 2. Ice machine will eventually start when water reaches normal lo level. 3. Replace water feed solenoid valve. 4. Replace PC board.

Replacement parts

Order parts online
www.follettice.com

Evaporator assembly

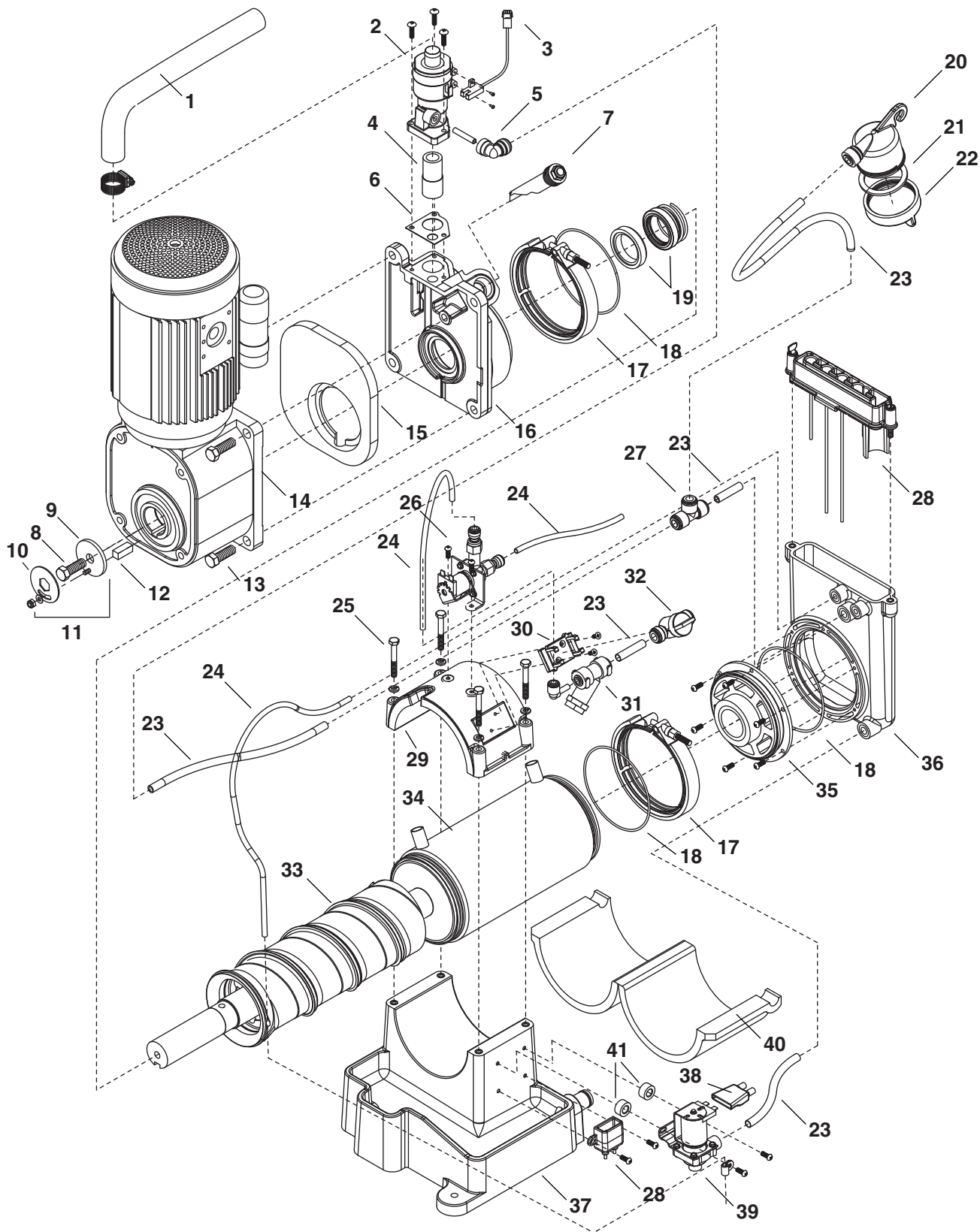

Reference #	Description	Part #
1	Tube, ice transport, molded	00130666
2	Shuttle assembly (includes 00115600 & 0013066)	00130815
3	Switch, optical	00130849
4	Compression nozzle	00115774
5	Elbow, water	00134502
6	Gasket, shuttle	00115600
7	Stream divider	00142513
8	Auger bolt	00116988
9	Washer	00161513
10	Retainer, auger bolt	00161356
11	Kit, auger bolt (auger bolt, washer, retainer, nut and washer)	00161406
12	Key	00117804
13	Bolts, gearmotor mounting (4)	00130641
14	Gearmotor, 120V (includes capacitor)	00130799
15	Gasket, gearmotor	00121632
16	Main housing (includes 00112946 & 00116962)	00142539
17	Coupling, V-band	00130708
18	O ring	00116962
19	Seal, auger shaft	00112946
20	Cup, sanitizer	00130674
21	Gasket, sanitizer	00124032
22	Cap, sanitizer (includes 00124032)	00130880
23	Tubing, water, 3/8" OD	502719
24	Tubing, water, 1/4" OD	502079
25	Hardware, mounting, evaporator cap	00130989
26	Solenoid, water feed (120V)	00130823
27	Tee, water	00134494
28	Sensor assembly, water level and drain clog	00130682
29	Cap, evaporator (includes 00125468 & 00130989)	00130740
30	Clip, water shut-off valve	502922
31	Strainer, water	502920
32	Valve, shut-off, water	502921
33	Auger (includes 00112946 & 00116962)	00147249
34	Evaporator (includes 00112946, (2) 00116962 & 00121116)	00130724
35	Journal housing and bearing (includes (2) 00116962)	00130716
36	Reservoir, water	00130690
37	Base, evaporator	00130732
38	Boot, solenoid	00160309
39	Solenoid, purge (120V)	00130757
40	Insulation, evaporator	00121616
41	Spacers, solenoid	00160317
Not shown	Insulation, evaporator cap	00125468

Low side assembly

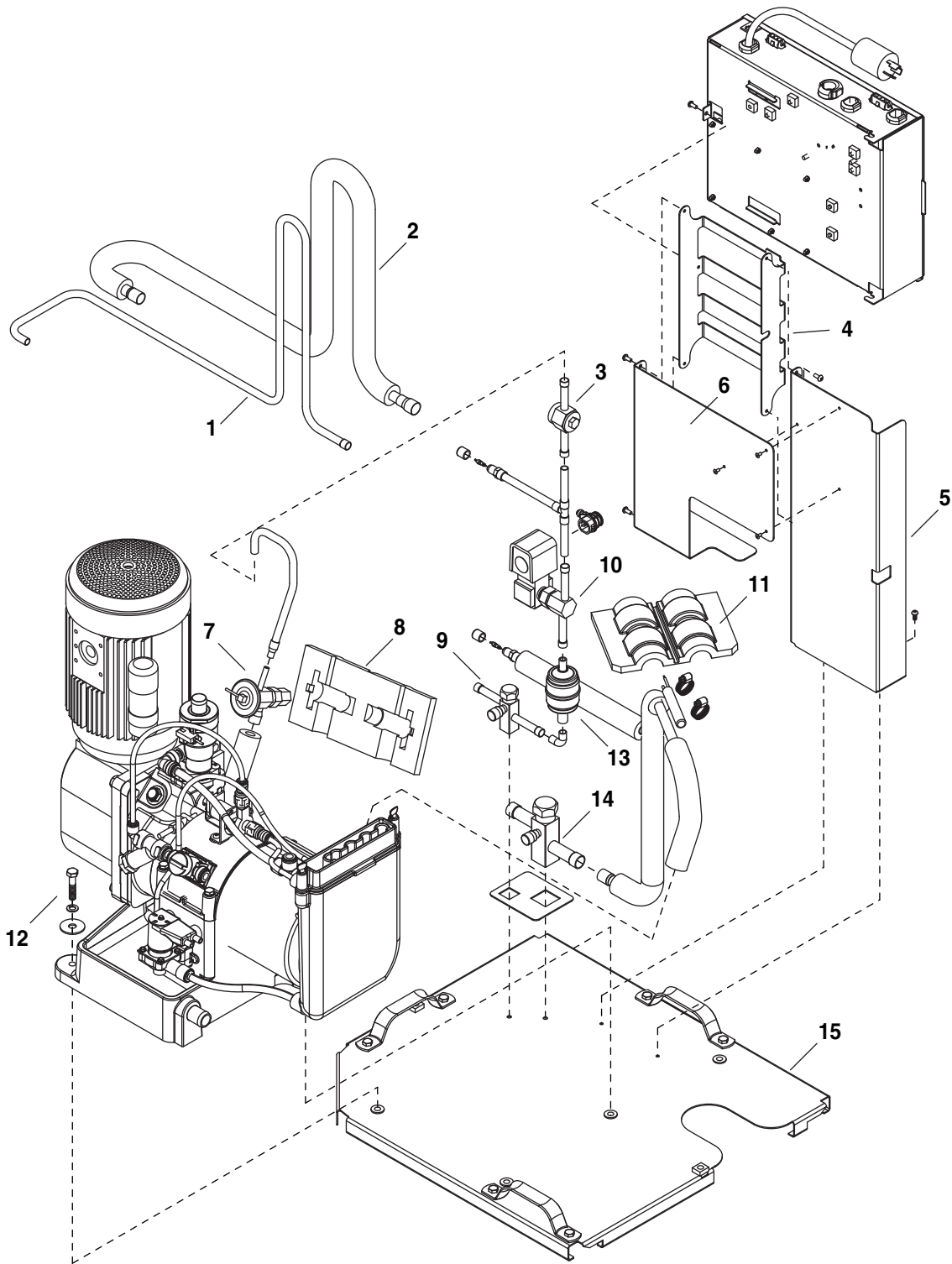

Reference #	Description	Part #
1	Tubing, liquid line	00142414
2	Tubing, suction line (includes insulation)	00131045
3	Sight glass	00107045
4	Electrical box support	00156035
5	Split system support	00156067
6	Extension	00156075
7	Valve, expansion, thermal (includes 502830 and 00106534)	00136317
8	Insulation, TXV	502830
9	Valve, shut-off, liquid line	00107060
10	Valve, solenoid	00107052
11	Insulation, bulb, TXV	00106534
12	Hardware, evaporator mounting base (set of four)	00130971
13	Drier	00134593
14	Valve, shut-off, suction line	00107078
15	Base, split system	00130864

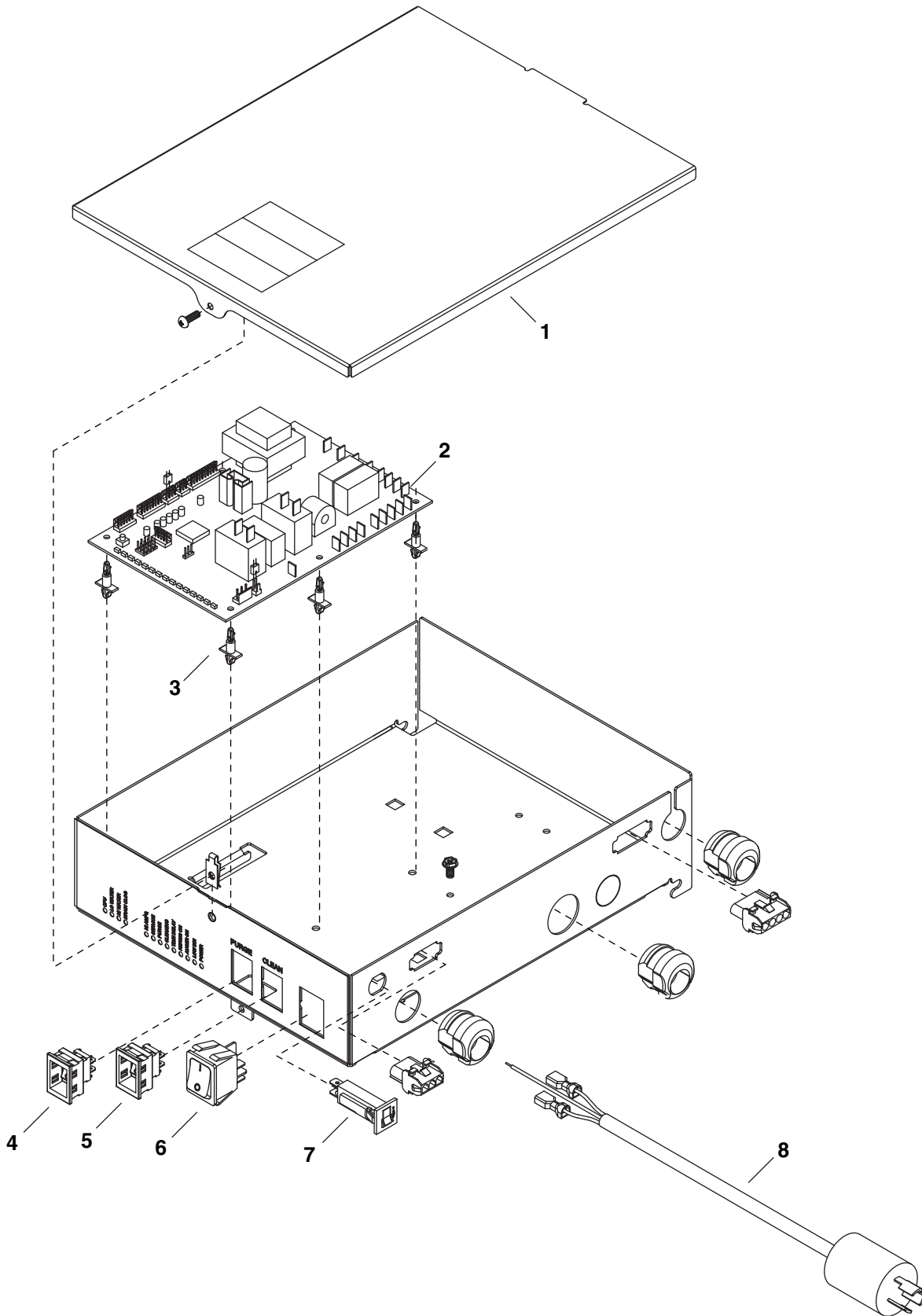

Reference #	Description	Part #
1	Cover, electrical box, remote	00130898
2	Board, control circuit, 120V (includes 00132910)	00132910
3	Stand off's (set of 6)	00130906
4	Switch, evaporator purge	00114371
5	Switch, evaporator clean	00117036
6	Switch, icemaker power	208867
7	Circuit breaker, 8 amp	00128090
8	Power lead	00134452

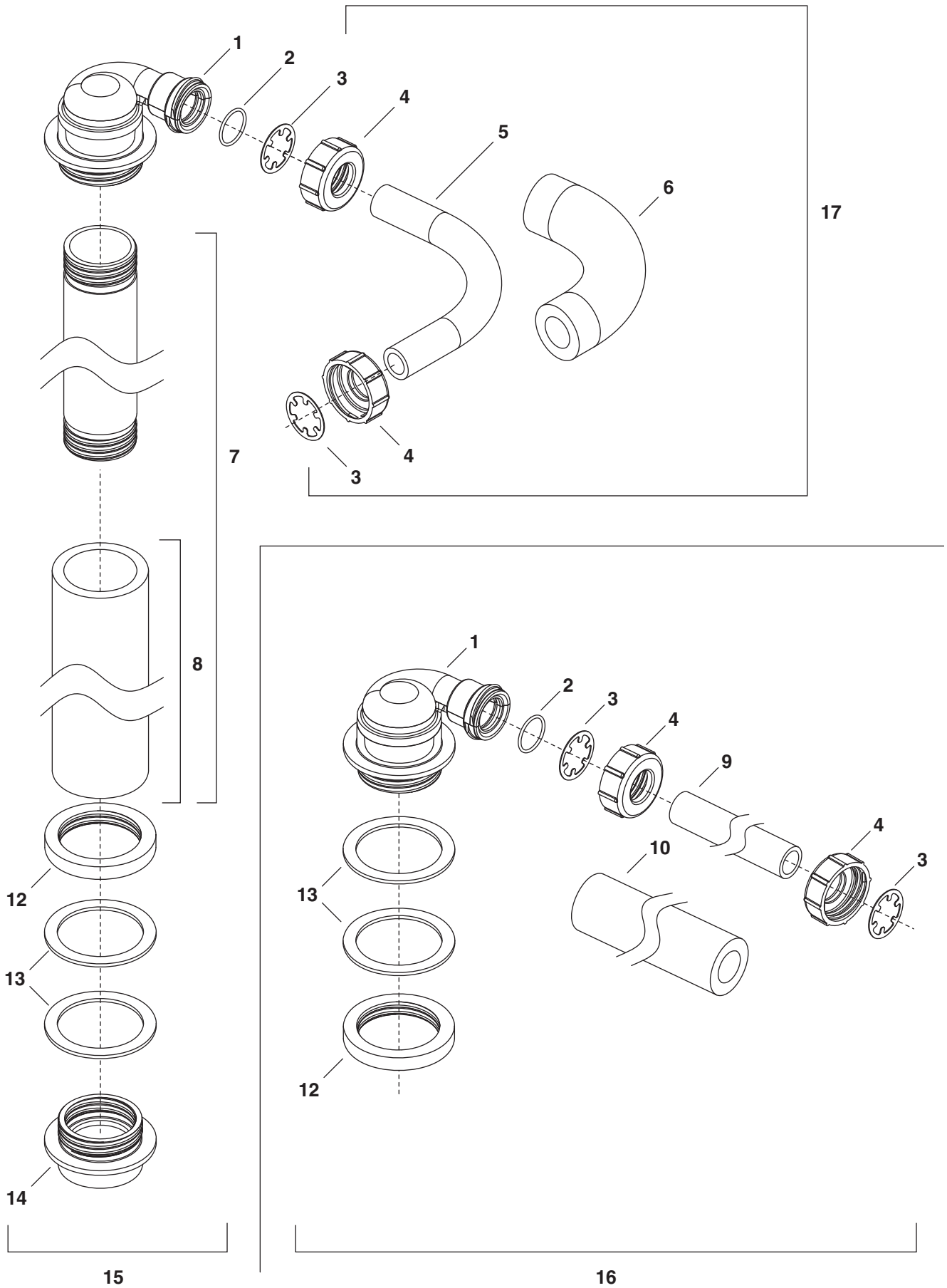

Reference #	Description	Part #
1	Shuttle actuator	00131029
2	O ring, ice tube	00123836
3	Retainer, ice tube	00129270
4	Nut, ice tube coupling	00122804
5	Tube, ice-fill, coupling to shuttle actuator	00119222
6	Insulation, coupling to shuttle actuator	00132605
7	Tube, ice-fill, 1400 top mount (includes 00128173)	00131011
8	Insulation, fill tube, 1400 top mount	00128173
9	Ice transport tube, 10' (3m)	502522
9	Ice transport tube, 20' (6m)	502523
10	Insulation, transport tube	501176
11	Coupling assembly	00131003
12	Ring, locking	00126508
13	Gasket, coupling	00126532
14	Coupling, fill tube	00126466
15	Integration kit, top mount	00134882
16	Integration kit, Satellite-fill (requires transport tube)	00134890
17	Assembly, (3, 4, 5 & 6)	00131037
Not shown	Anti-kink elbow kit	00136358
Not shown	Extension-fill tube, 9"	00135723
Not shown	Extension-fill tube, 4"	00153684
Not shown	Follett SafeCLEAN ice machine cleaner (case of 24 x 7oz packets)	00132001

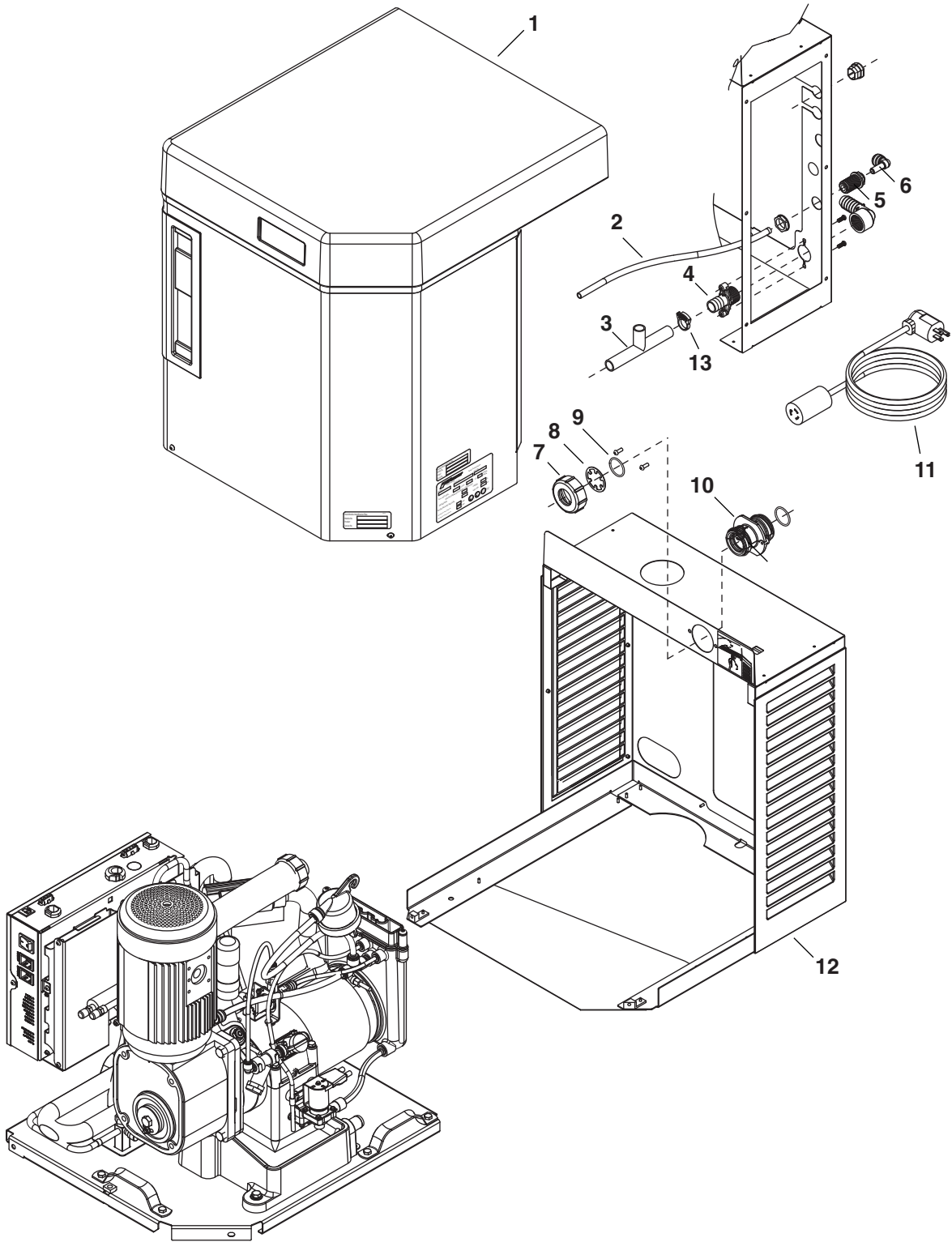

Reference #	Description	Part #
1	Front cover, split system	00130633
2	Tubing, water, 1/4" OD	502079
3	Tubing, drain	00144923
4	Fitting, drain	00109728
5	Fitting, water inlet	502924
6	Elbow, water inlet	502925
7	Nut, ice tube coupling	00122804
8	Retainer, ice tube	00129270
9	O ring, ice tube	00123836
10	Coupling, ice tube	00123091
11	Power cord, 120V	00134437
12	Louvered docking assembly, split system (includes 00123182)	00136937
13	Clamp, drain line	00114520

Condensing unit

Order parts online
www.follettice.com

Top View

Side View

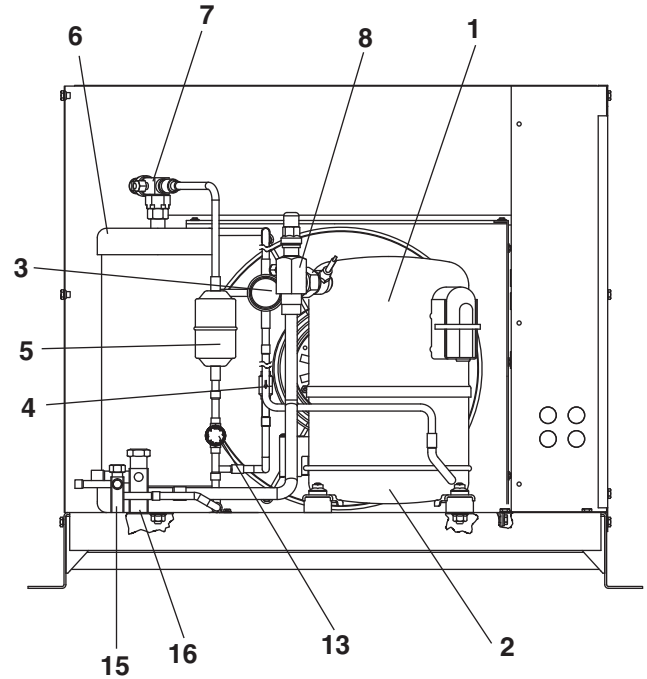
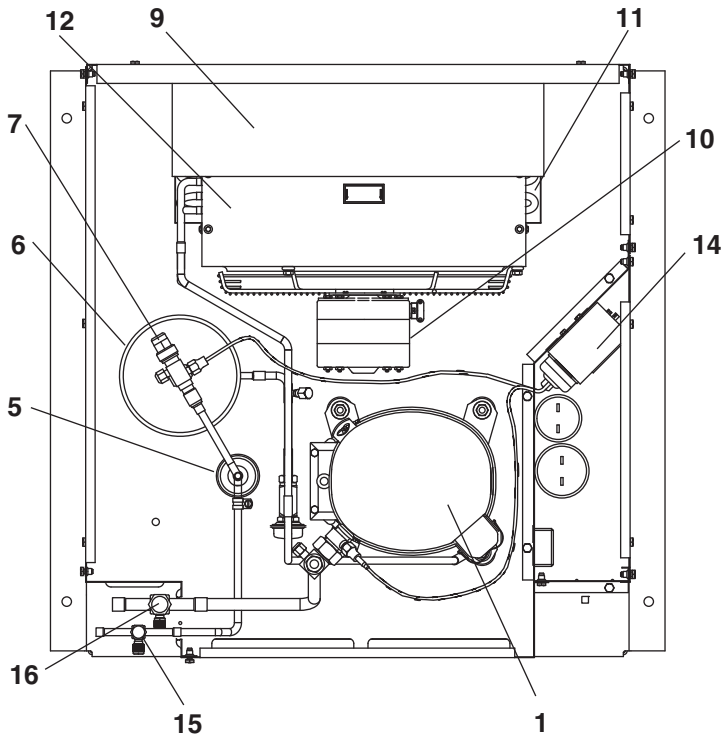

Reference #	Description	Part #
1	Compressor	00110544
Not shown	Starting capacitor	00110569
Not shown	Run capacitor	00110577
Not shown	Starting relay	00110585
2	Crankcase heater	00123042
3	Head pressure control valve	00110619
4	Check valve	00110650
5	Filter drier	00156265
6	Receiver	00110627
7	Receiver service valve	00110692
8	Service valve, suction line	00110643
9	Condenser	00110668
10	Condenser fan motor	00110601
11	Condenser fan guard	00123067
Not shown	Condenser fan blade	00123075
12	Shroud	00120170
13	Sight glass	00155911
14	Dual pressure control	00155945
15	Shut-off valve, liquid line	00107060
16	Shut-off valve, suction line	00107078
Not shown	Gasket, receiver service valve	00155960
Not shown	Gasket, compressor service valve	00155978

Chevrolet is a registered trademark of Follett Corporation, registered in the US.