

HCC1000A, HCC1000W Icemakers

Order parts online
www.follettice.com

Operation and Service Manual
After Serial Number C20000

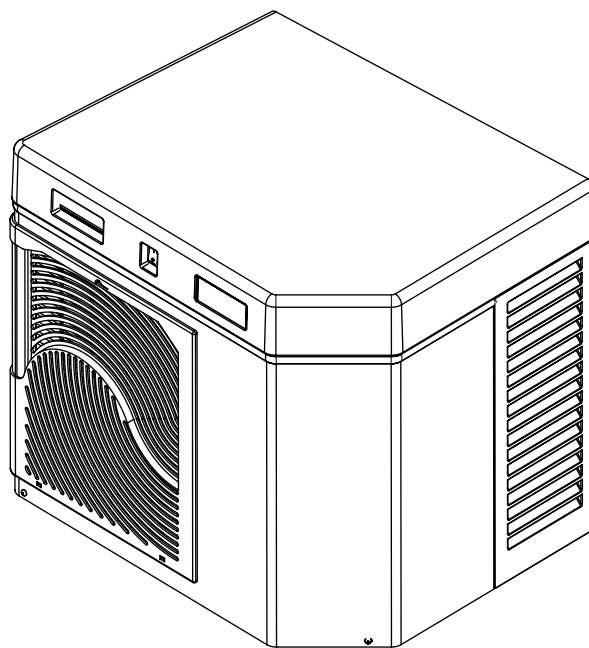

**Following installation, please forward this manual
to the appropriate operations person.**

**Follett Corporation
Equipment Return Policy**

Follett equipment may be returned for credit under the following conditions:

1. The equipment is new and unused.
2. A return authorization number has been issued by customer service within 30 days after shipment.
3. Follett receives the equipment at the factory in Easton, PA within 30 days after issuance of the return authorization number.
4. The equipment must be returned in Follett packaging. If the packaging has been damaged or discarded, Follett will forward, at the customer's expense, new packaging.

Note: Return freight charges are the responsibility of the customer. If equipment is returned and is damaged because of improper packaging, Follett Corporation will not be held responsible.

Credit will be issued when:
The equipment has been inspected by Follett and deemed suitable to be returned to stock.

Note: A 15% restocking charge will be deducted from the credit. If the cost to return the product to stock exceeds 15%, the actual cost will be deducted.

Table of contents

Welcome to Follett Corporation	4
Specifications	5
Operation	7
Cleaning	7
Weekly exterior care	7
Monthly condenser cleaning	7
Semi-annual evaporator cleaning	7
Service	12
Icemaker operation	12
Water system	13
Electrical system	14
Normal control board operation	14
Test points	15
Time delay and self-flushing jumpers	15
Error faults	15
Hard error	15
Soft errors	15
Relay output indication	15
Compressor/refrigerant solenoid output	15
Wiring diagram	16
Compressor data	17
Gearmotor data	17
Resistance of windings	17
Mechanical system	18
Evaporator disassembly	18
Evaporator reassembly	20
Refrigeration system	23
Refrigeration pressure data	23
Refrigeration system diagram	23
Refrigerant charge size	24
Refrigerant replacement requirements	24
Evacuation	24
Ambients	24
Ice capacity test	24
Bin full detection system	25
Troubleshooting	26
Replacement parts	28

Welcome to Follett

Follett equipment enjoys a well-deserved reputation for excellent performance, long-term reliability and outstanding after-the-sale support. To ensure that this equipment delivers the same degree of service, we ask that you review the installation manual (provided as a separate document) before beginning to install the unit. Our instructions are designed to help you achieve a trouble-free installation. Should you have any questions or require technical help at any time, please call our technical service group at (800) 523-9361 or (610) 252-7301.

Before you begin

After uncrating and removing all packing material, inspect the equipment for concealed shipping damage. If damage is found, notify the shipper immediately and contact Follett Corporation so that we can help in the filing of a claim, if necessary.

Check your paperwork to determine which model you have. Follett model numbers are designed to provide information about the type and capacity of Follett equipment. Following is an explanation of the different model numbers in the 1000 series.

Horizon Series Icemaker Model Number Configurations

Icemaker	Voltage	Series	Condenser	Application	Configuration
HC Horizon Chewblet	C 208-230/60/1 <i>(self-contained only)</i>	1000 up to 1036 lbs (471kg)	A Air-cooled, self-contained	V Vision™	S Satellite-fill™
HM Horizon MINI Chewblet	D Low side 115/60/1 Condensing unit 208-230/60/1 <i>(remote condensing only)</i>	1400 up to 1450 lbs (658kg)	W Water-cooled, self-contained	H Harmony™	T Top-mount
	E 230/50/1 <i>(self-contained only)</i>		R Air-cooled, remote condensing unit	B Ice storage bin	
			N Air-cooled, no condensing unit for connection to parallel rack system	J Drop-in	
				M Ice Manager† diverter valve system	

† Ice Manager Diverter Valve Systems can be used to fill any two of these bins or dispensers with a single ice machine.

Chewblet is a registered trademark of Follett Corporation, registered in the US.

CAUTION

- Warranty does not cover exterior or outside installations.
- Moving parts. Do not operate with front cover removed.
- Hot parts. Do not operate with cover removed.
- To reduce risk of shock, disconnect power before servicing.
- Most ice machine cleaners contain citric or phosphoric acid, which can cause skin irritation. Read caution label on product and follow instructions carefully.
- Ice is slippery. Maintain counters and floors around dispenser in a clean and ice-free condition.
- Ice is food. Follow recommended cleaning instructions to maintain cleanliness of delivered ice.

Specifications

Electrical

Each icemaker requires its own separate circuit with electrical disconnect within 10 ft (6m).
 Equipment ground required.
 Standard electrical – 208-230/60/1
 Maximum icemaker fuse – 15 amps each
 Amperage – 11 amps
 6 ft (2m) NEMA 6-15 cord and plug provided on icemaker

Plumbing

3/8" OD push-in water inlet
 3/4" MPT drain
 1/4" FPT condenser inlet (water-cooled condenser only)
 1/4" FPT condenser drain (water-cooled condenser only)

Notes: 3/4" vented drain line must slope a minimum of 1/4" per foot (6mm per 30.4cm run).
 Drain to be hard piped and insulated.
 To prevent back flow, do not connect drains.
 Separate drains for icemaker and condenser.
 Water shut-off recommended within 10 feet (3m).
 Follett recommends installation of Follett water filter system (part# 00130286) in icemaker inlet water line.

Ambient

Air temperature	100 F/38 C max.	50 F/10 C min.
Water temperature	90 F/32 C max.	45 F/7 C min.
Water pressure – potable	70 psi max. (483 kPa)	10 psi min. (89 kPa)

Note: Water-cooled condenser pressure 150 psi (1034 kPa)

Heat rejection

Air-cooled rejects 11,300 BTU/hr
 Water-cooled rejects 12,800 BTU/hr

Ice production

Air-cooled icemaker capacity/24 hrs.

		Ambient Air Temperature F/C					
		F	60	70	80	90	100
Inlet Water Temperature F/C	50	1135	1100	962	828	786	lbs
	10	515	499	437	376	357	kg
	60	1070	1000	916	816	728	lbs
	16	486	454	416	371	331	kg
	70	1015	938	871	794	686	lbs
	21	461	426	395	361	312	kg
	80	967	902	826	755	654	lbs
	27	439	410	375	343	297	kg
	90	924	859	782	698	610	lbs
	32	420	390	355	317	277	kg

Water-cooled icemaker capacity/24 hrs.

		Ambient Air Temperature F/C					
		F	60	70	80	90	100
Inlet Water Temperature F/C	50	1071	1035	975	885	762	lbs
	10	486	470	443	402	346	kg
	60	1025	979	912	826	723	lbs
	16	465	444	414	375	328	kg
	70	971	932	870	786	683	lbs
	21	441	423	395	357	310	kg
	80	912	888	839	759	642	lbs
	27	414	403	381	345	292	kg
	90	849	842	814	745	603	lbs
	32	386	382	370	338	274	kg

Dimensions and clearances

Entire front of icemaker must be clear of obstructions/connections to allow removal.

1" (26mm) clearance above icemaker for service.

1" (26mm) minimum clearance on sides.

The intake and exhaust air grilles must provide at least 150 sq in (968 sq cm) of open area.

Air-cooled model HCC1000A icemakers – 18" (458mm) minimum clearance between discharge and air intake-grilles.

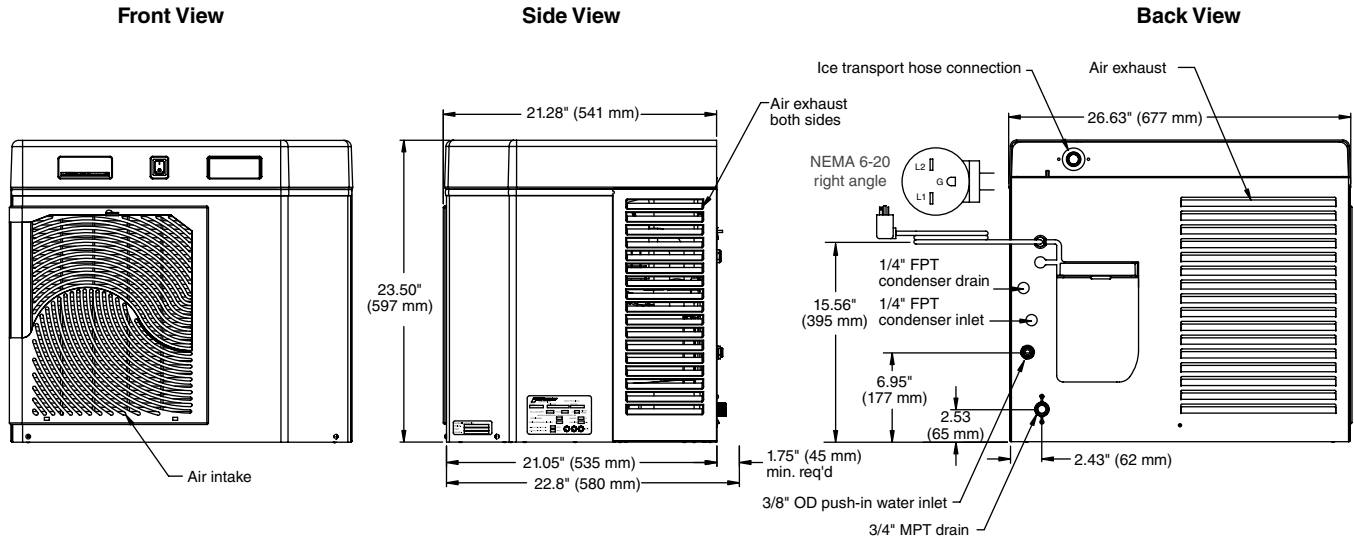

Operation

Cleaning and preventive maintenance (all models)

Note: Do not use bleach to sanitize or clean the icemaker.

Preventive maintenance

Periodic cleaning of Follett's icemaker system is required to ensure peak performance and delivery of clean, sanitary ice. The recommended cleaning procedures that follow should be performed at least as frequently as recommended, and more often if environmental conditions dictate.

Cleaning of the condenser can usually be performed by facility personnel. Cleaning of the icemaker system, in most cases, should be performed by your facility's maintenance staff or a Follett authorized service agent. Regardless of who performs the cleaning, it is the operator's responsibility to see that this cleaning is performed according to the schedule below. Service problems resulting from lack of preventive maintenance will not be covered under the Follett warranty.

Weekly exterior care

The exterior may be cleaned with a stainless cleaner such as 3M Stainless Steel Cleaner & Polish or equivalent.

Monthly condenser cleaning (air-cooled icemaker only)

1. Use a vacuum cleaner or stiff brush to carefully clean condenser coils of air-cooled icemakers to ensure optimal performance.
2. When reinstalling counter panels in front of remote icemakers, be sure that ventilation louvers line up with condenser air duct.

Semi-annual evaporator cleaning (every 6 months)

WARNING

- Wear rubber gloves and safety goggles (and/or face shield) when handling ice machine cleaner or sanitizer.

CAUTION

- Use only Follett approved SafeCLEAN™ Cleaner (part #00132001) and NU-CALGON IMS-II SANITIZER.
- Do not mix Cleaner and Sanitizer solutions together.
- DO NOT USE BLEACH.
- It is a violation of Federal law to use these solutions in a manner inconsistent with their labeling.
- Read and understand all labels printed on packaging before use.

Note: Complete procedure for cleaning and sanitizing MUST be followed. Ice must be collected for 10 minutes before putting ice machine back into service.

1. To clean – Remove cover. Press the CLEAN button. The machine will drain. Wait for the LO WATER light to come on (Fig. 1).

Note: For Ice Manager diverter valve application, refer to manual #00169045 for icemaker and diverter valve cleaning process.

Fig. 1

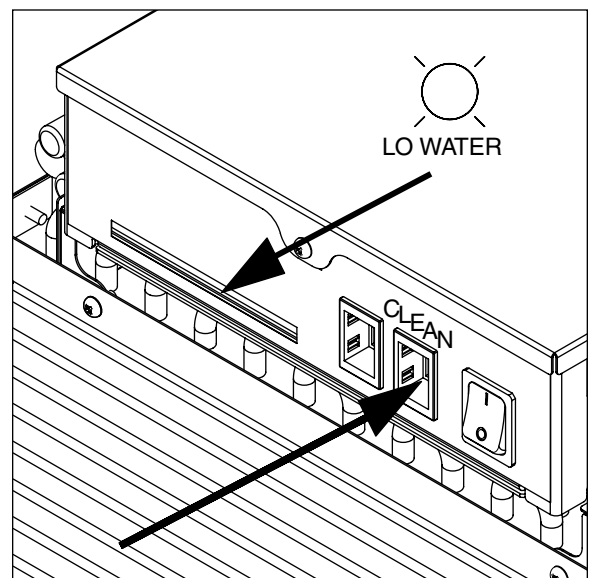

- Mix 1 gallon (3.8L) 120 F (49 C) water and 7 ounces (198g) (one 7 ounce packet of Follett SafeCLEAN ice machine cleaner, part#-00132001). Locate cleaning cup. Fill until HI WATER light comes on (Fig. 2).

Note: Do not use bleach to sanitize or clean the icemaker.

Fig. 2

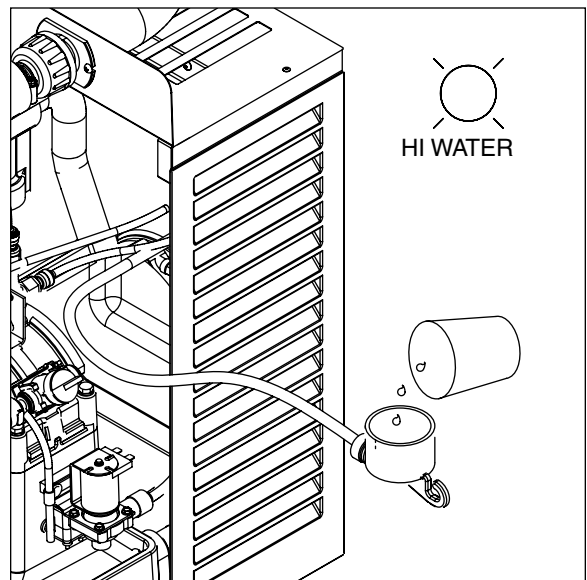

- Replace cover on cleaning cup. Wait until machine restarts. Machine will clean, then flush 3 times in approximately 12 minutes (Fig. 3).

Fig. 3

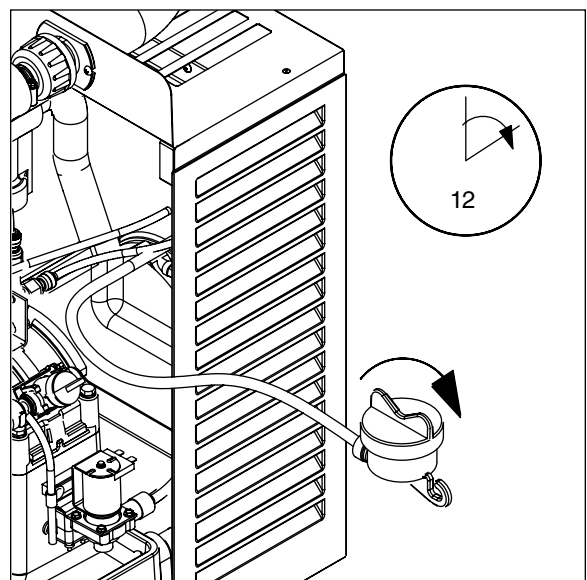

- To sanitize – Press CLEAN button. The machine will drain. Wait for LO WATER light to come on (Fig. 4).

Fig. 4

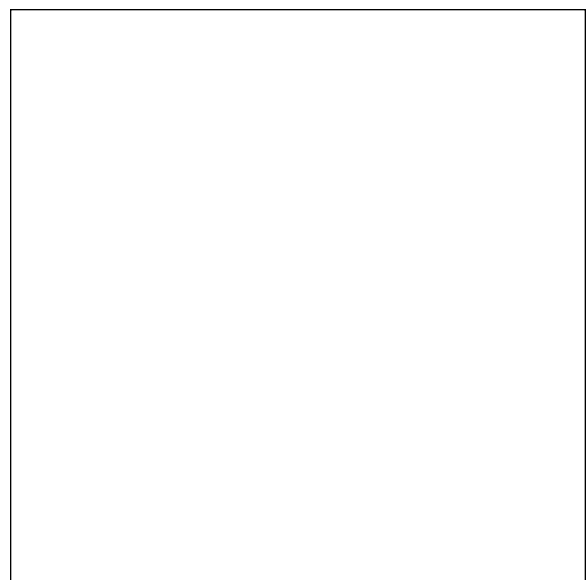

- Mix 1 gallon 120 F (49 C) water and 1.6 ounces (48ml) NU-CALGON IMS-II SANITIZER. Fill until HI WATER light comes on (Fig. 5).

Note: Do not use bleach to sanitize or clean the icemaker.

Fig. 5

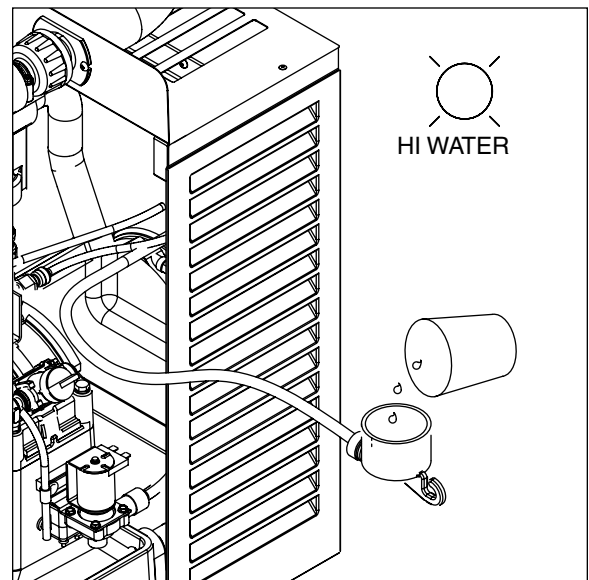

- Replace cover on cleaning cup. Wait until machine restarts. Machine will sanitize, then flush 3 times in approximately 12 minutes (Fig. 6).

Fig. 6

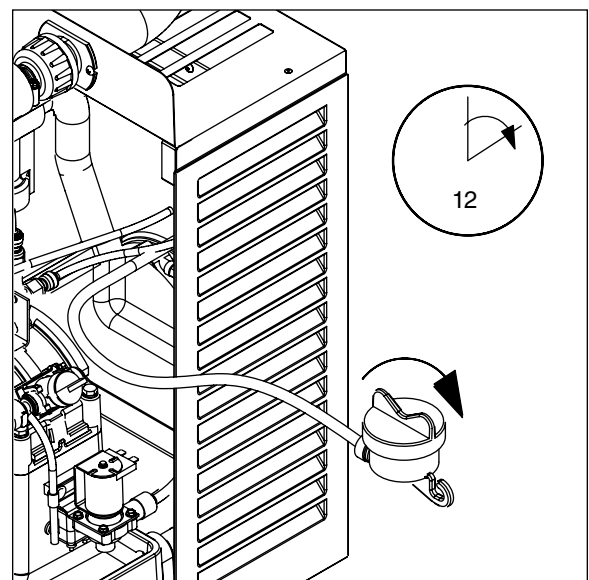

- To clean transport tube – Press power switch OFF (Fig. 7).

Fig. 7

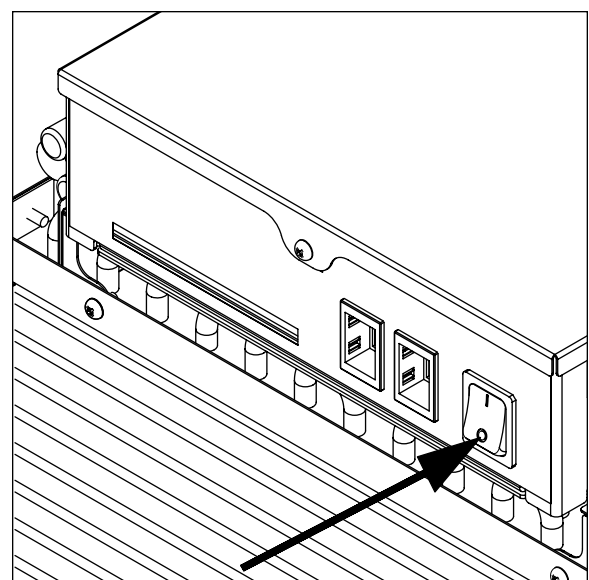

8. Disconnect coupling as shown (Fig. 8).

Fig. 8

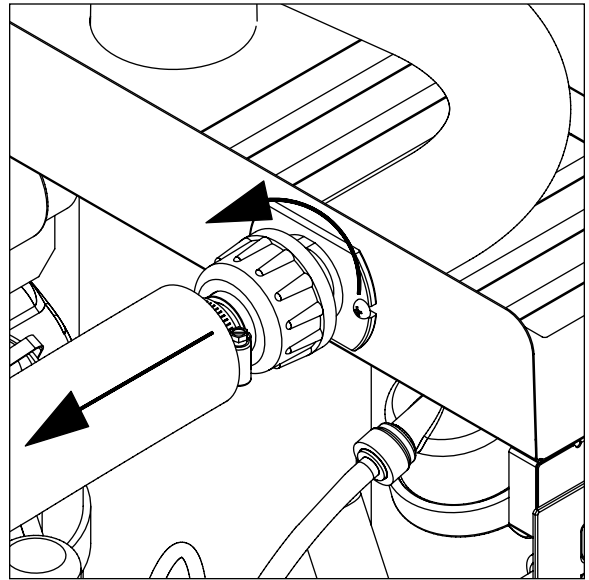

9. Using disposable food service grade gloves, insert dry Sani-Sponge™ (kit part# 00132068). Next, -insert Sani-Sponge soaked in Nu-Calgon IMS-II sanitizer solution. Push both Sani-Sponges down ice transport tube with supplied pusher tube (Fig. 9).

Fig. 9

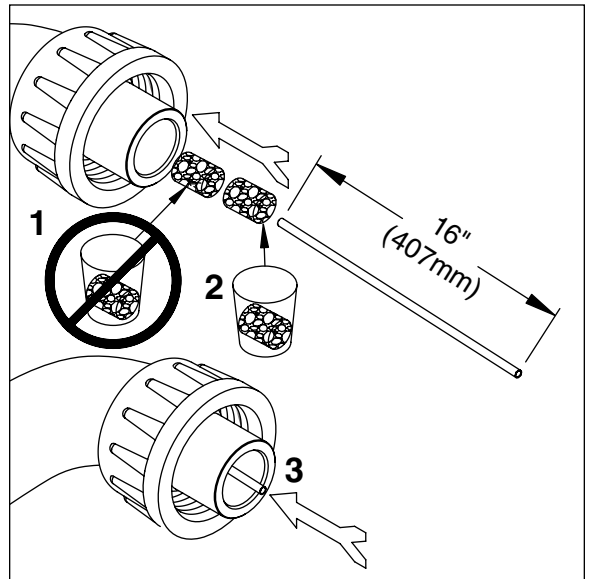

10. Remove and discard 16" (407mm) pusher tube (Fig. 10).

Fig. 10

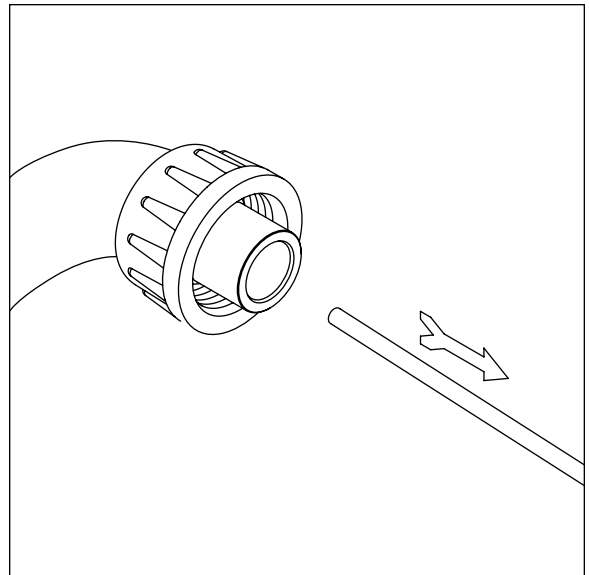

11. Reconnect coupling. Press power switch ON. Ice pushes Sani-Sponges through tube (Fig. 11).

Fig. 11

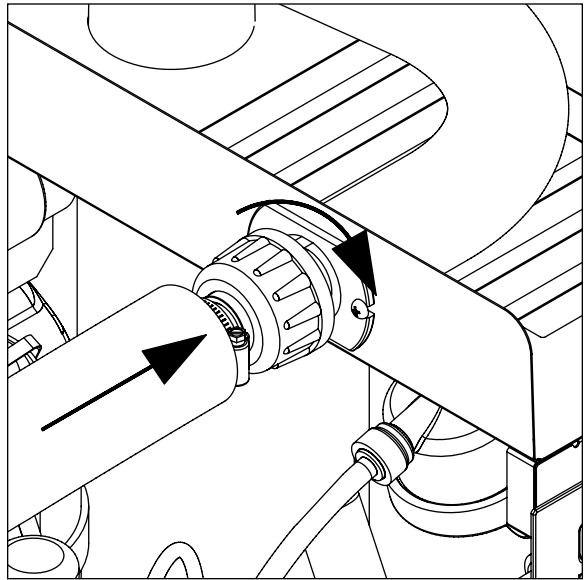

12. Place a sanitary (2 gallon or larger) container in bin or dispenser to collect Sani-Sponges and ice for 10 minutes. Collect 5.5 lbs (3kg) of ice from unit. Discard ice and Sani-Sponges (Fig. 12).

Fig. 12

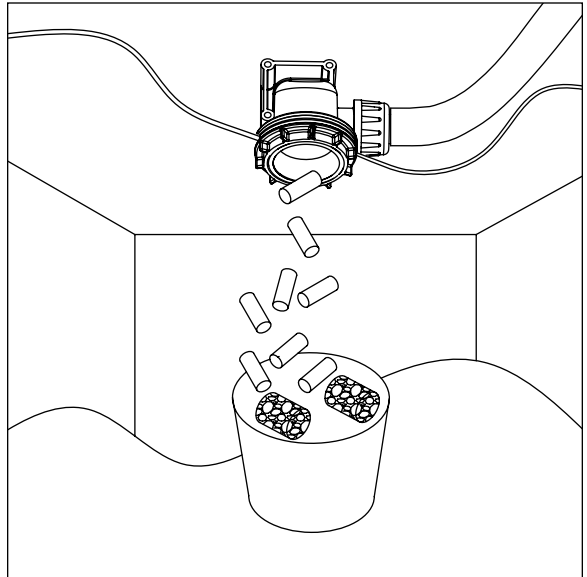

Service

Icemaker operation (all models)

Follett's icemaker consists of five distinct functional systems covered in detail as follows:

- Water system
- Electrical control system
- Mechanical assembly
- Refrigeration system
- Bin full

The Horizon icemaker overview

The Follett Horizon icemaker uses a horizontal, cylindrical evaporator to freeze water on its inner surface. The refrigeration cycle is continuous; there is no batch cycle. The evaporator is flooded with water and the level is controlled by sensors in a reservoir. A rotating auger (22 RPM) continuously scrapes ice from the inner wall of the evaporator. The auger moves harvested ice through the evaporator into an ice extrusion canal. The ice is forced through a restrictive nozzle that squeezes out the water and creates the Chewblet. The continuous extrusion process pushes the Chewblets through a transport tube into a dispenser or bin.

A solid state PC board controls and monitors the functionality of the ice machine. In addition to sequencing electrical components, the board monitors various operational parameters. A full complement of indicator lights allows visual status of the machine's operation. Additionally, the PC board controls the self-flushing feature of the icemaker. The evaporator water is periodically drained and replenished to remove minerals and sediment.

A unique "bin full" detection system is incorporated in the Horizon icemaker. A switch located at the ice discharge port of the machine detects the position of the transport tube. When the bin fills up with ice, the transport tube moves out of the normal running position, and the switch turns the ice maker off. A domed housing at the end of the transport tube contains the ice extrusion loads during shut down.

Harvest system diagram

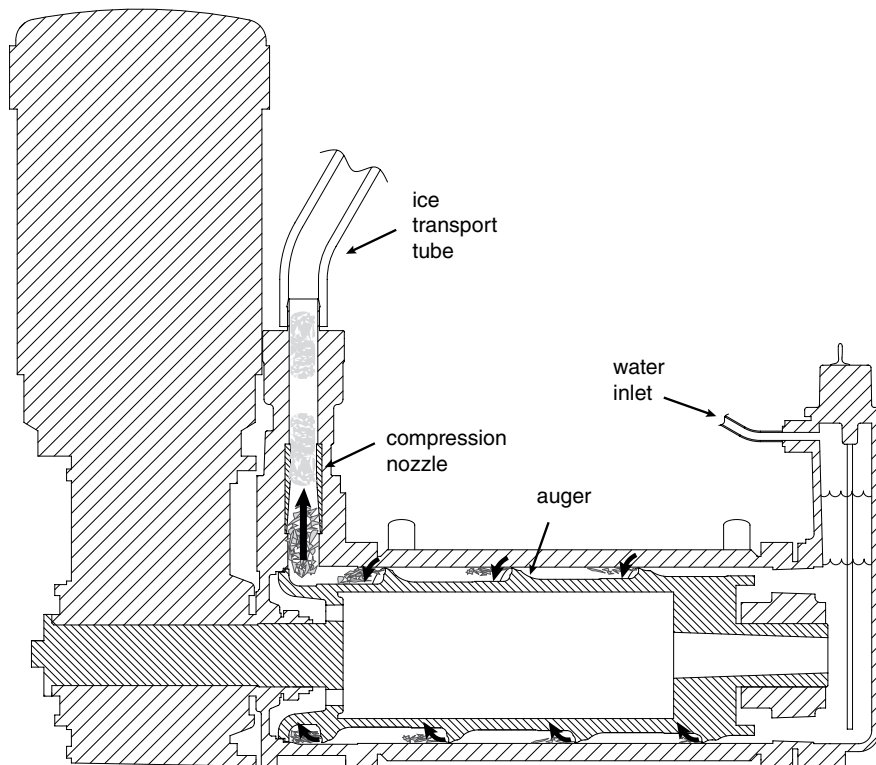

Water system

The water level in the evaporator is controlled by a feed solenoid and level detecting sensors. Referencing the diagram below, water sensing rods extend down into the reservoir at the end of the evaporator assembly. The system works via electrical conductivity as follows:

One of the longest probes is a common. When water is between any of the other probes and the common, the PC board will sense the activation. During normal operation, the water level rises and falls between the Normal High and Normal Low sensors. As water is consumed to make ice, the level will fall until the Normal Low sensor is exposed, triggering the water feed solenoid on. Water will fill until the Normal High sensor is activated.

Note: The potable water dissolved solids content must be greater than 10 ppm for the water control system to function properly. If using reverse osmosis water filtration system, ensure T.D.S level is greater than 10 ppm.

Water system diagram

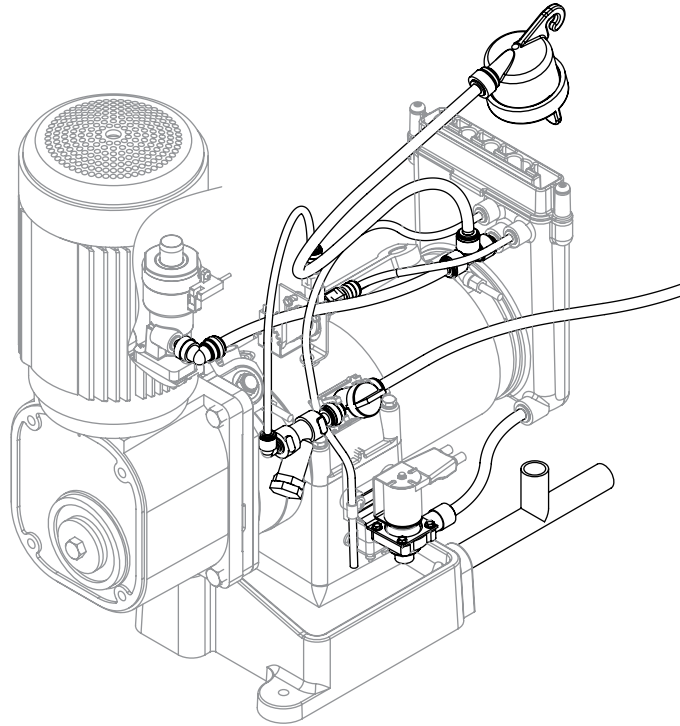

Water level diagram

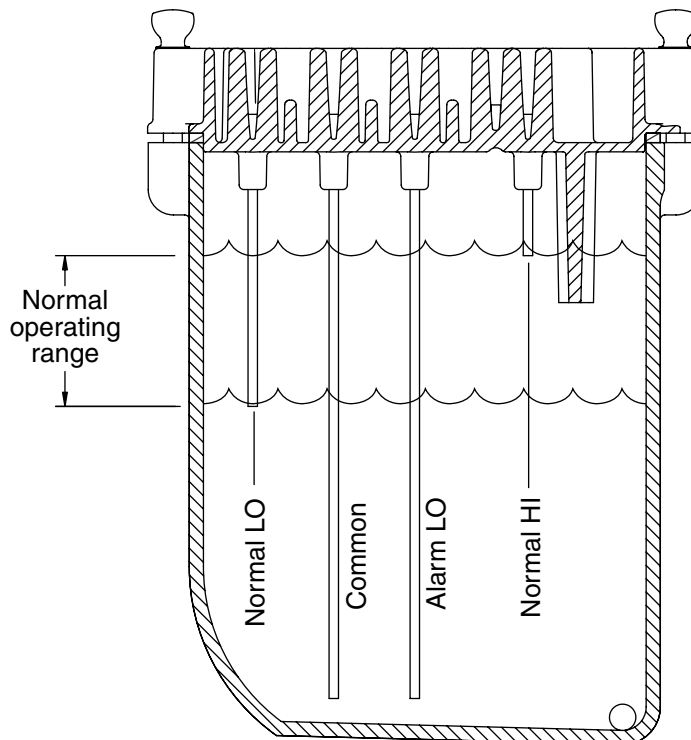

Electrical system

Normal control board operation

The PC board indicator lights provide all the information necessary to determine the machine's status. Green indicator lights generally represent “go” or normal operation; Yellow indicators represent normal off conditions; Red indicators generally represent alarm conditions, some of which will lock the machine off.

A green light labeled POWER indicates power to the machine. A flashing green light labeled CPU is normal and indicates that the Central Processing Unit “heart beat” is working. All other normal operation status indicators are covered as follows:

Ice machine disposition	Operating conditions
Legend: ● ON ○ OFF ◐ ON or OFF ✖ FLASHING	

1. Ice machine is making ice.

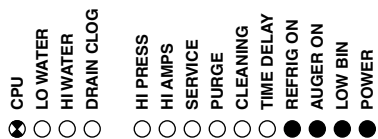

1. Normal running.

2. Ice machine is not making ice.



2. **Normal time delay.** When the bin fills with ice, the LOW BIN light goes out and the refrigeration and auger drive systems immediately shut down. (**Note:** The fan motor will continue to run for 10 minutes to cool condenser) The TIME DELAY light comes on, initiating the time delay period. When the time delay expires, the machine will restart provided that the LOW BIN light is on.

3. Ice machine is not making ice.



3. **Normal purge indicator.** After a selected period of ice making time has elapsed (1 or 2 hours), the ice machine will automatically self-flush. The compressor will shut down but the fan and gearmotor will continue to run. After the flush is complete the machine will refill and start without a time delay.

Test points:

The Horizon PC board incorporates on-board test points that can be used to determine various electrical outputs. The test point holes allow a standard probe to be inserted for quick voltage measurement. For 208-230 systems, use TP-4 (L2) as the common for testing outputs for solenoids, motors, etc.

Error faults:

The Horizon PC board monitors various operating parameters including high pressure, auger gearmotor amperage limits, clogged drain, and high and low water alarm conditions. There are two types of errors namely "hard" or "soft." A hard error is one that shuts the machine off and will not allow restart until the reset button is pressed. Even cycling power will not reset a hard error. A soft error can either be automatically reset should the condition rectify, or if power is cycled. Should an error occur, consult the troubleshooting guide in this manual or a Follett service technician. **Note:** there are two types of LO WATER and HI AMPS errors as listed below.

Soft errors:

HI AMPS: The PC board monitors the amperage of the auger motor. Should the gear motor experience current draw above the 3.8 amps limit the machine will shut down and the TIME DELAY, HI AMP, and SERVICE LED's will be illuminated. After the time delay the machine will restart and the TIME DELAY, HI AMP, and SERVICE LED's will clear.

LO WATER: During operation, the water level cycles between the normal low and normal high sensors. Should the water be shut off to a running machine, a soft error will occur. The error sequence is as follows: During operation, the water level falls to the normal low sensor, and when it does the water feed solenoid is energized. If water is not detected at the normal low sensor within 120 seconds, a soft error will occur. The machine will shut down, but the water feed solenoid will remain energized. Should water return, it will fill to the normal low sensor and the machine will resume normal operation. The error will clear automatically.

DRAIN CLOG: The drain clog sensor, located in the plastic drain pan behind the drain solenoid, will detect the presence of water just below the top edge of the pan. If water does not properly flow out of the drain pan it will rise to the sensor, especially during a self-flushing purge cycle.

Hard error:

HI AMPS:

1. "Two strikes" feature. If the gearmotor has a second HI AMP occurrence during the countdown period (6 hours after a HI AMP time delay) a hard error will occur and the HI AMP and SERVICE LED's will be illuminated.
2. No current. To prevent the refrigeration system from running without gearmotor rotation the PC board will indicate HIGH AMP and SERVICE if the drive relay is energized and there is no current draw.

HI PRESSURE: Should the refrigeration pressure rise above 425 psi, a hard error will occur. Even if pressure fall-back below the reset point of 295 psi, the error will not clear and the machine will not restart.

LO WATER:

1. There is a sensor in the water reservoir that reaches down to the very bottom. The machine will not start if water is not present at this sensor.
2. A hard error will occur should water not be present within 60 seconds of power up or if the sensors are disconnected or damaged.

Relay output indication:

Each relay on the board has an indicator light associated with its output. For example, when the relay for the water feed solenoid is energized, the adjacent indicator light glows green.

Comp/Sol output:

The output for the compressor is labeled COMP/SOL.

Wiring diagram

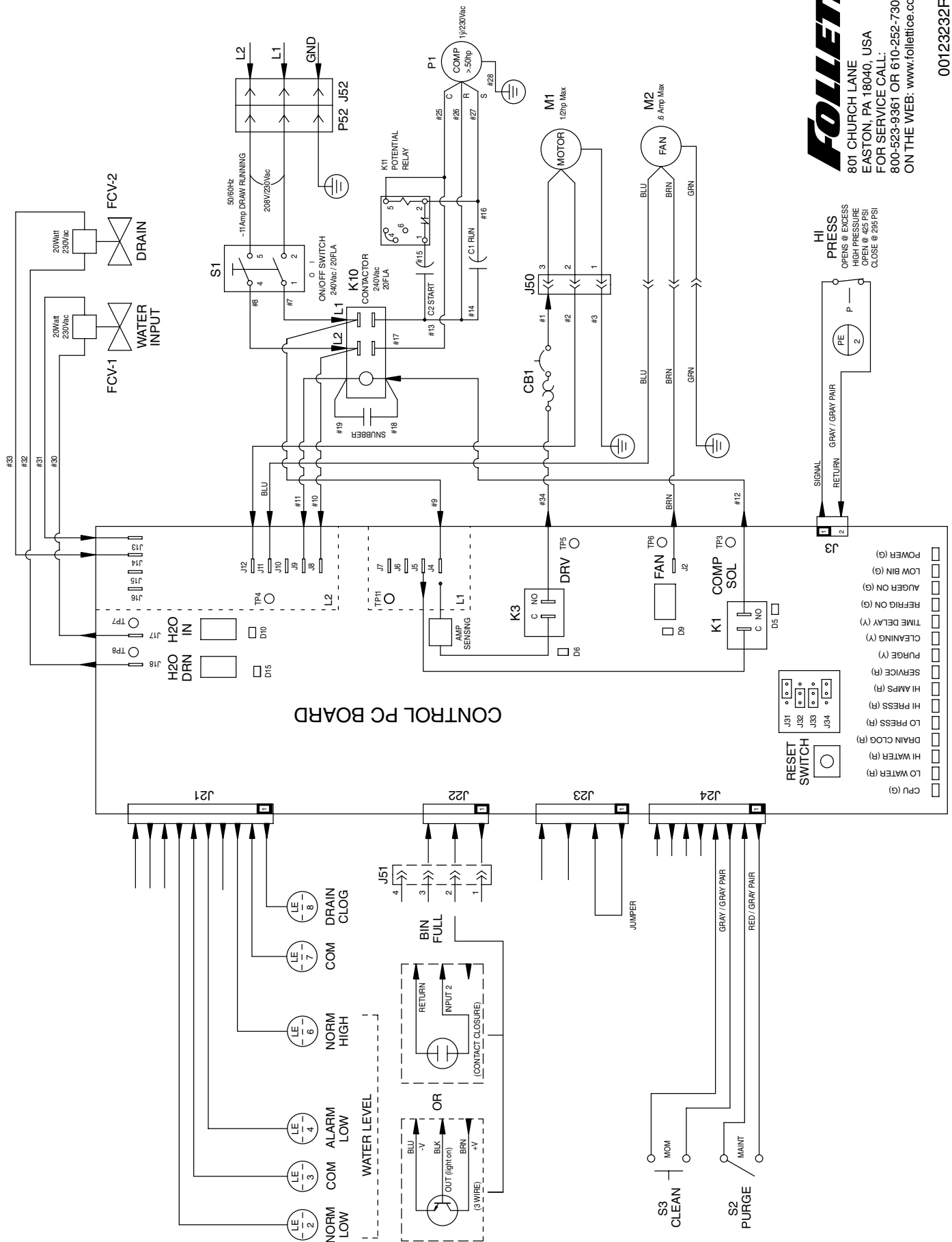

FOLLETT

801 CHURCH LANE
EASTON, PA 18040, USA
FOR SERVICE CALL:
800-523-9361 OR 610-252-7301
ON THE WEB: www.follettice.com

00123232R10

Compressor data**Compressor current draw at 230 VAC****Air-cooled**

Ambient air temp.	60 F/16 C	70 F/21 C	80 F/27 C	90 F/32 C	100 F/38 C
	7.1	7.5	7.8	7.8	8.1

Water-cooled

Condenser water temp	50 F/10 C	60 F/16 C	70 F/21 C	80 F/27 C	90 F/32 C
	7.0	7.0	7.4	6.7	8.0

Locked rotor amps 54

Gearmotor data**Brother**

Gearmotor current 2.8A (nominal)

Locked rotor amps 15 amps

Resistance of windings

208-230 vac gearmotor (Brother) 6.2Ω

Compressor start winding 3.0Ω

Compressor run winding 1.4Ω

Fan motor 38Ω

Mechanical system

Evaporator disassembly

1. Press PURGE button to purge evaporator, and then turn power OFF.
2. Unscrew and remove stream divider as shown.

Fig. 13

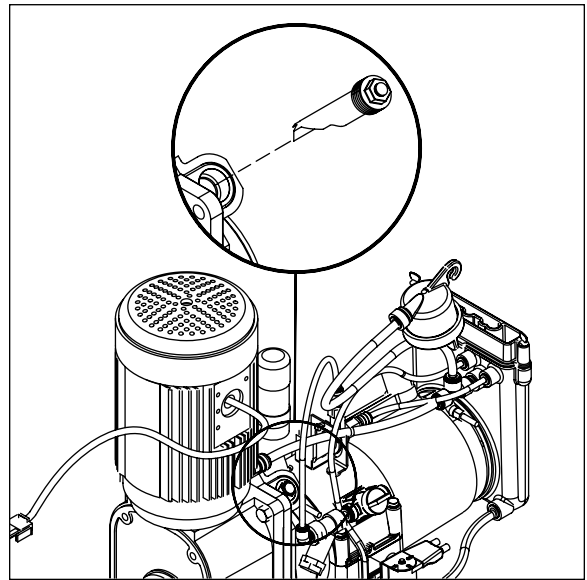

3. Unplug and remove gearmotor as shown.
4. Remove all traces of petrol-gel from the auger shaft.

Fig. 14

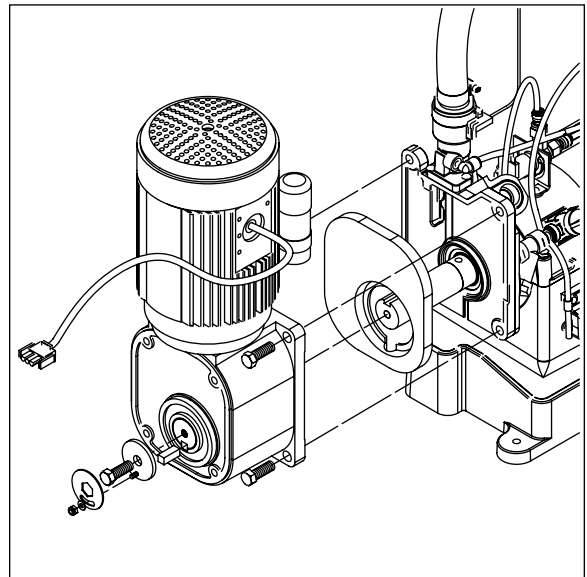

5. Unscrew and disconnect transport tube from louvered docking assembly.
6. Unplug sensor at the electrical box.
7. Remove vent tube from shuttle housing as shown.

Fig. 15

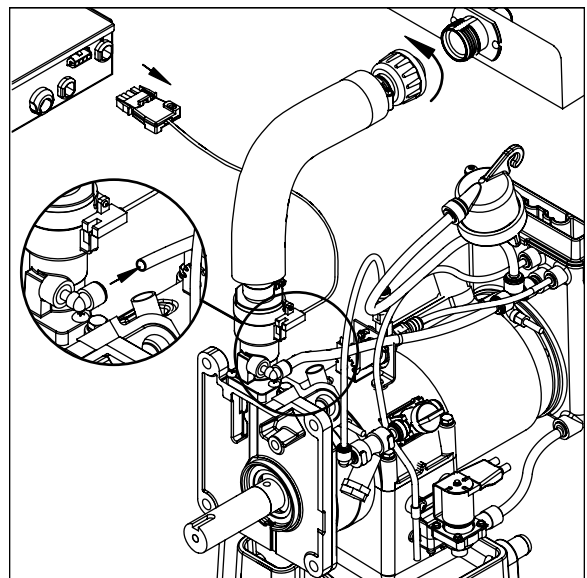

8. Loosen nut on V-band clamp and remove.
9. Remove V-band clamp from front of evaporator.
10. Remove main housing as shown.

Fig. 16

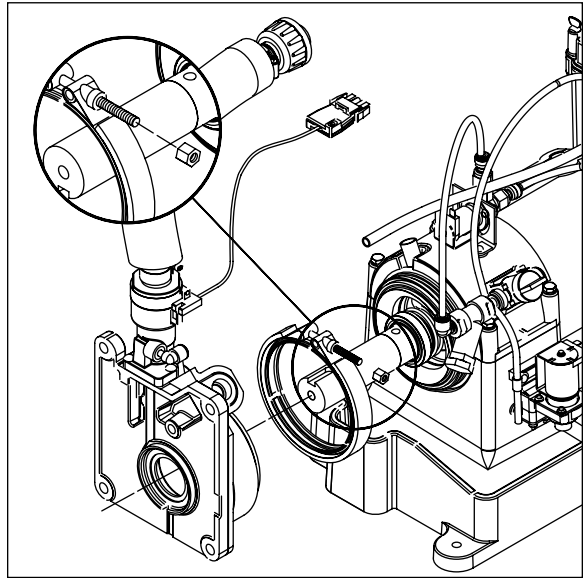

11. Remove and discard mating ring and seal.
12. Carefully remove auger.

Fig. 17

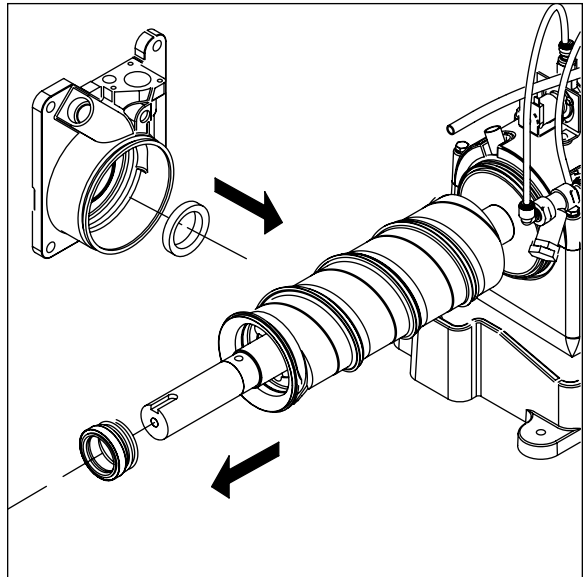

Evaporator reassembly

1. Remove and inspect O ring seal. Discard if damaged in any way.
2. Clean O ring groove. Lubricate O ring with petrol-gel and reinstall.

Fig. 18

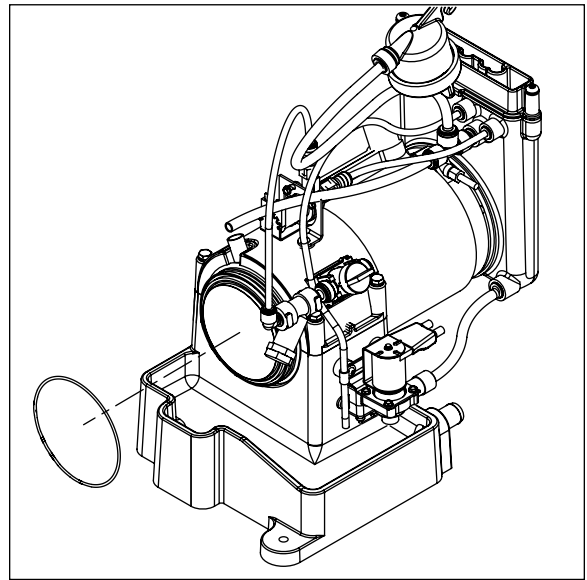

3. Press new mating ring into main housing as shown.
4. Lube the shaft with liquid soap in the area shown and slip on seal and spring.

Note: Do not touch the sealing surfaces. Use cardboard disc to install.

Fig. 19

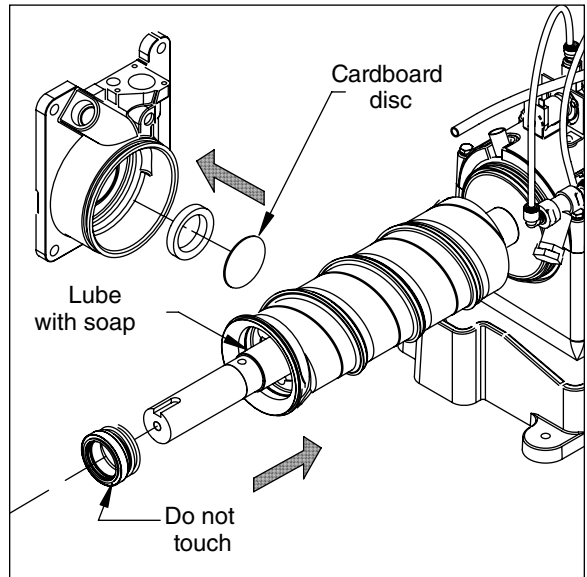

5. Reinstall main housing as shown.

Fig. 20

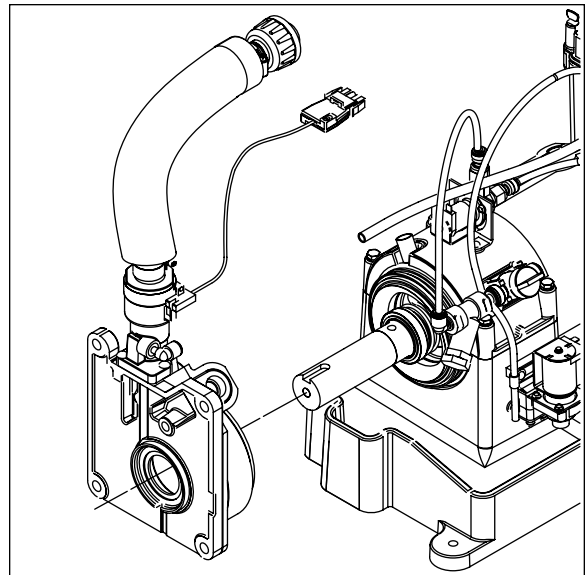

6. Orient auger shaft with keyway in the upward position.
7. Force main housing into position against evaporator and place 1/4" (7mm) diameter Phillips screwdriver into hole in the auger shaft.
8. Replace V-band clamp as shown.
9. Replace nut on V-band clamp and tighten.
10. Remove screwdriver.

Fig. 21

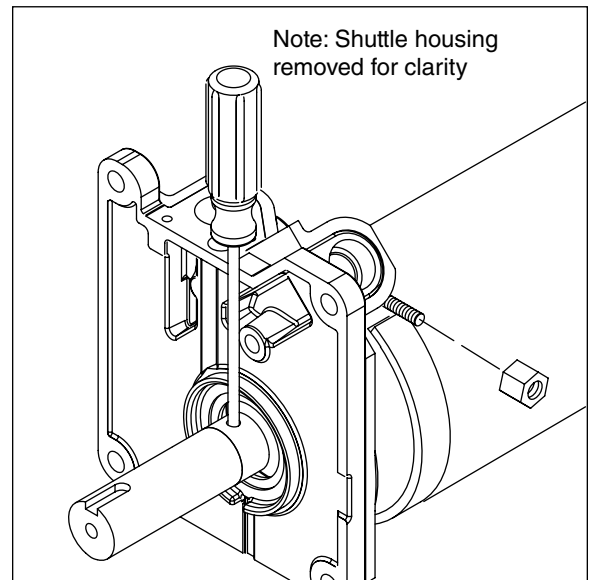

11. Reconnect transport tube to louvered docking assembly.
12. Plug sensor in at the electrical box.
13. Reconnect vent tube to the shuttle housing as shown.

Fig. 22

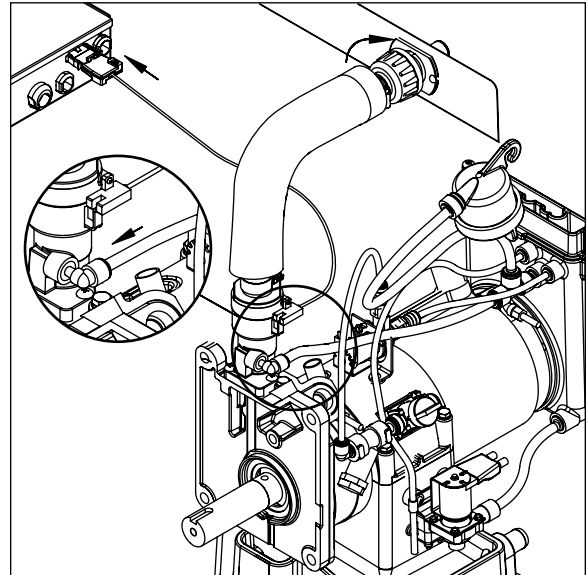

14. Apply a coat of petrol-gel to the auger shaft.
15. Install gearmotor, making sure that insulation is properly seated between gearmotor and main housing as shown.
16. Firmly tighten four gearmotor bolts in place.

Fig. 23

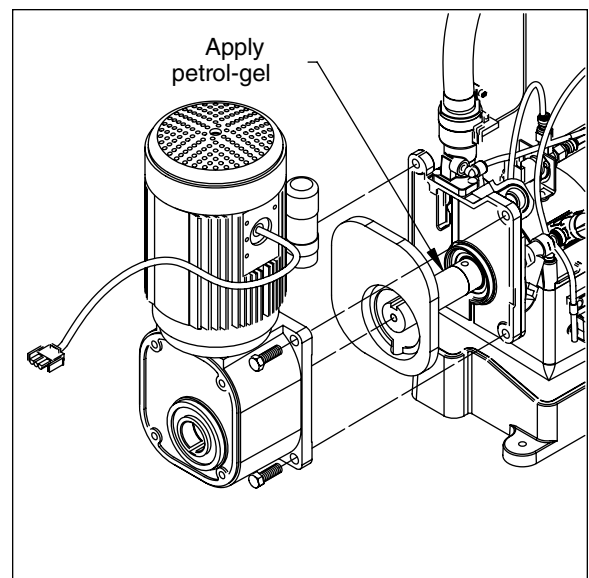

17. Insert a bolt into the auger shaft and finger tighten.
18. Using a wrench, rotate the shaft clockwise to align the keyways in the gear housing and the shaft so as to accept the key.
19. Insert the key into the keyway.

Fig. 24

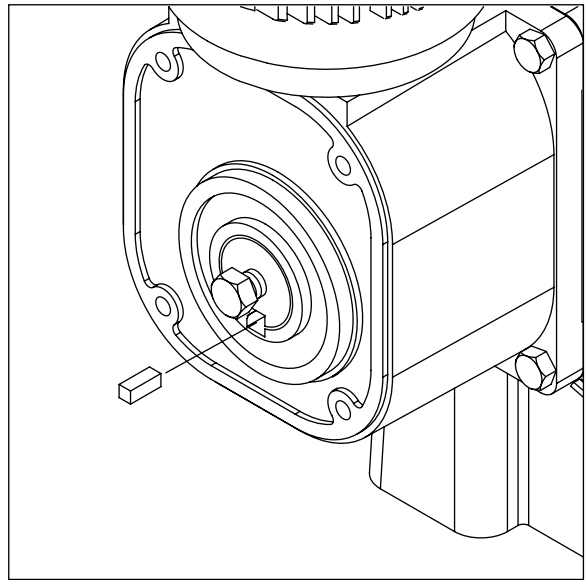

20. Remove bolt and reinstall the washer and bolt. Place retainer over bolt and secure with nut and washer.

Fig. 25

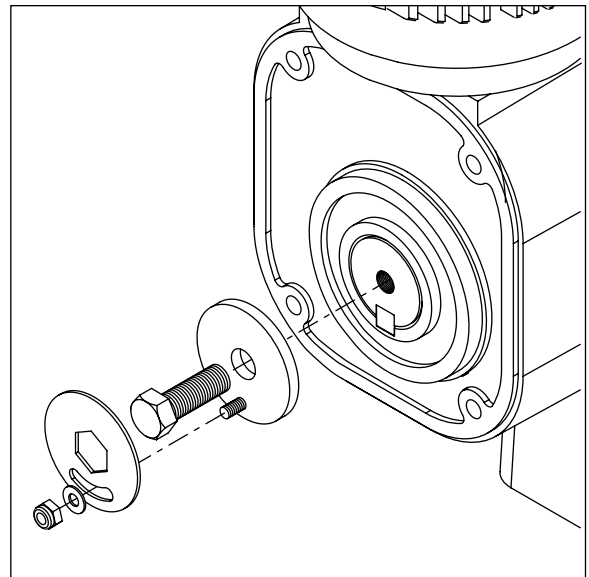

21. Lubricate body of stream divider with petrol-gel and reinstall.
22. Plug gearmotor power cord into electrical box.

Fig. 26

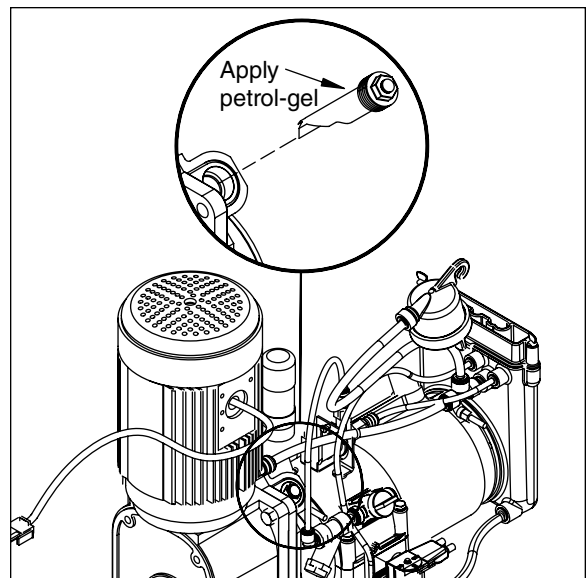

Refrigeration system

Refrigerant pressure data

Air-cooled condensers (air)	60 F/16 C	70 F/21 C	80 F/27 C	90 F/32 C	100 F/38 C
Pressure (psig) discharge/suction	218/31	241/33	277/35	313/38	349/41
Water-cooled condensers (water)	60 F/16 C	70 F/21 C	80 F/27 C	90 F/32 C	100 F/38 C
Pressure (psig) discharge/suction	219/33	225/33	231/33	232/34	236/40

Note: The water control valve is factory set to maintain 230 ± 15 psi discharge pressure @ 70 F water.

Refrigeration system diagram

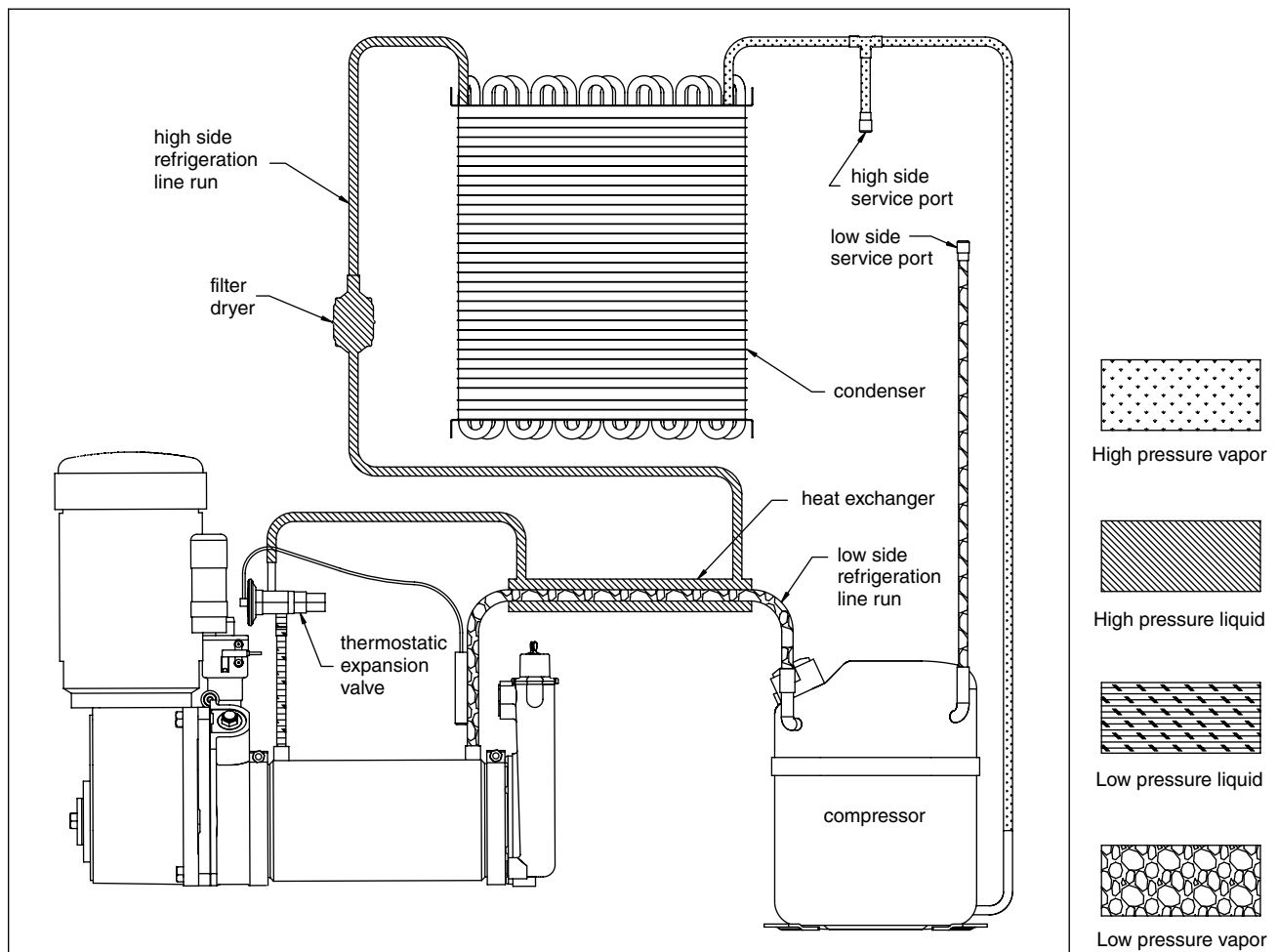

Refrigeration charge

All service on refrigeration systems must be performed in accordance with all federal, state and local laws. It is the responsibility of the technician to ensure that these requirements are met. Recharging icemaker to other than factory specifications will void the warranty.

R404A icemaker charge specifications		
Model	Charge	Refrigerant type
HC/MC1000A (air-cooled)	24oz (652g)	R404A
HC/MC1000W (water-cooled)	15oz (426g)	R404A

Refrigerant replacement requirements

1. Non-contaminated refrigerant removed from any Follett refrigeration system can be recycled and returned to the same system after completing repairs. Recycled refrigerant must be stored in a clean, approved storage container. If additional refrigerant is required, virgin or reclaimed refrigerant that meets ARI standard 700-88 must be used.
2. In the event of system contamination (for example, a compressor burn out, refrigerant leak, presence of non-condensibles or moisture), the system must be repaired, evacuated and recharged using virgin or reclaimed refrigerant that meets ARI standard 700-88.
3. Follett Corporation does not approve of recovered refrigerants. Improper refrigeration servicing procedures will void the factory warranty.

Evacuation

Evacuate the system to a level of 500 microns. When the 500 micron level is reached, close all valves. Allow the system to sit for approximately 20 minutes. During this period the system pressure should not rise. If the system pressure rises and stabilizes there is moisture in the system and further evacuation is needed. If the pressure continues to rise check the system for leaks.

Ambients	Minimum	Maximum
Air temperature ¹	50 F/10 C	100 F/37.8 C
Water temperature ²	45 F/7 C	90 F/32.2 C

¹Ambient air temperature is measured at the air-cooled condenser coil inlet.

²Ambient water temperature is measured in the icemaker water reservoir.

Ice capacity test

Icemaker production capacity can only be determined by weighing ice produced in a specific time period.

1. Replace all panels on icemaker.
2. Run icemaker for at least 15 minutes.
3. Weigh and record weight of container used to catch ice.
4. Catch ice for 15 or 20 minutes.
5. Weigh harvested ice and record total weight.
6. Subtract weight of container from total weight.
7. Convert fractions of pounds to decimal equivalents (ex. 6 lbs 8oz = 6.5 lbs).
8. Calculate production using following formula:

$$\frac{1440 \text{ min.} \times \text{wt. of ice produced}}{\text{Total test time in minutes}} = \text{Production capacity/24 hr. period}$$

9. Calculated amount per 24 hours should be checked against rated capacity for same ambient and water temperatures in Ice Production Tables.

“Bin full” detection system

The Follett Horizon icemaker incorporates a unique “bin full” detection system that consists of the shuttle and actuator. The shuttle incorporates a flag and sensor. Referencing the figure below, the normal running position of the flag is down, out of the sensor. When the bin fills to the top and ice can no longer move through the tube, the machine will force the shuttle flag up into the sensor, shutting the machine off. The shuttle actuator, located above the ice bin allows the ice to curl up within it when the bin is full. In this way, there are no loads generated that would tend to lift off the lid of the bin.

Shuttle flag and sensor

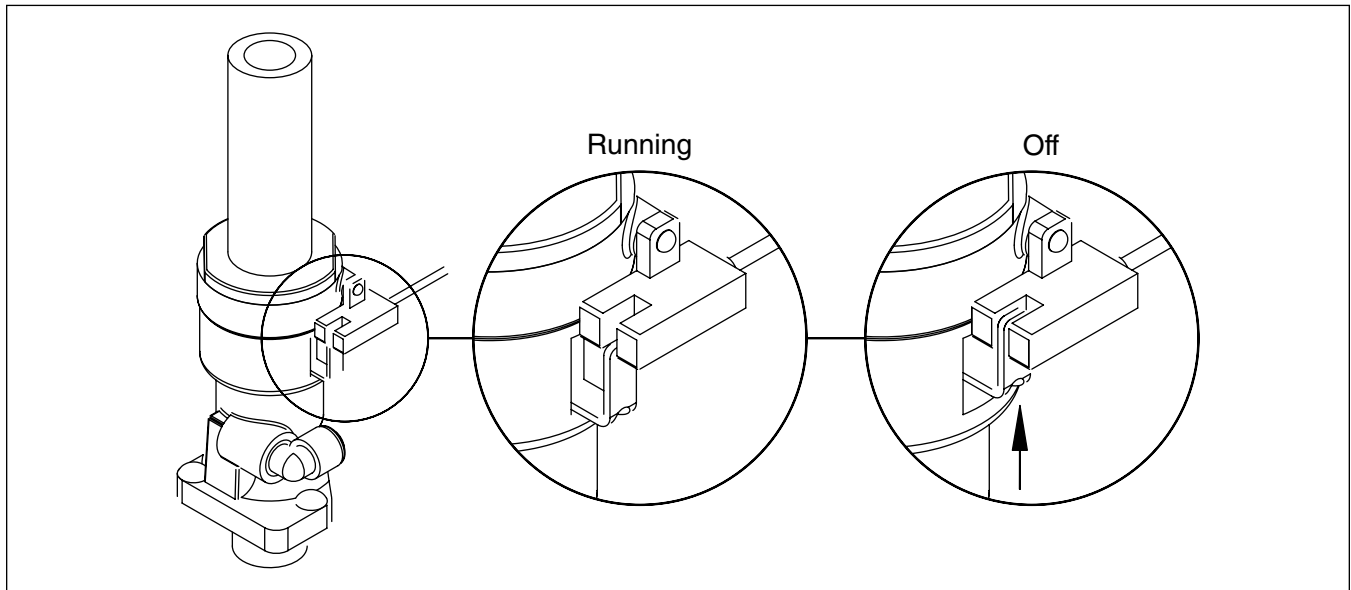

Shuttle actuator

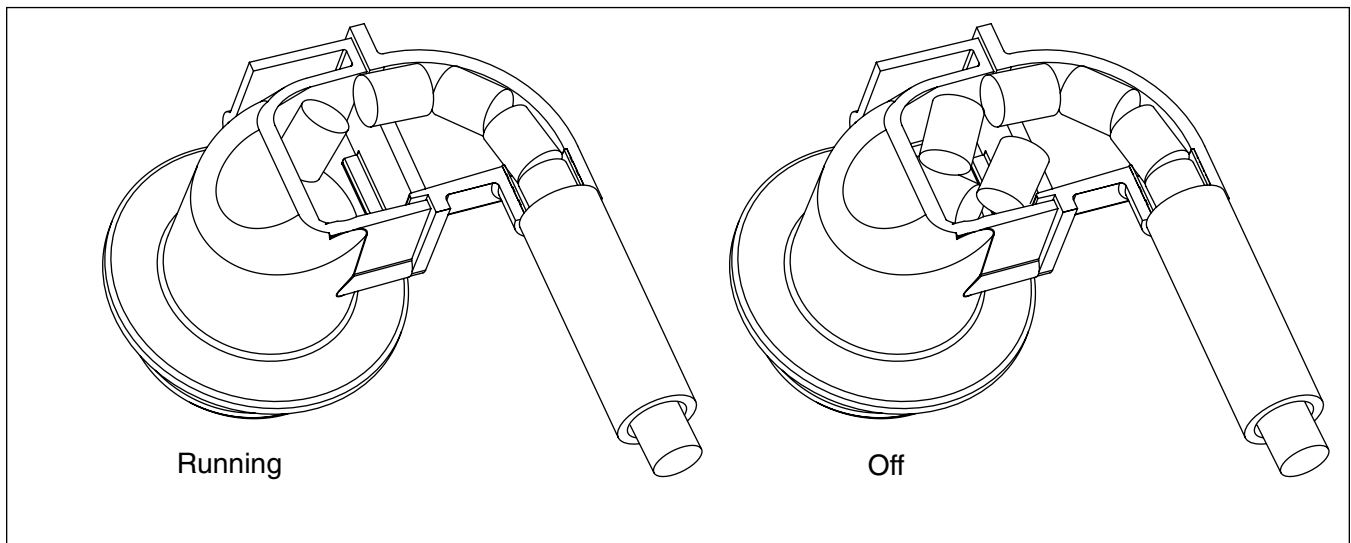

Troubleshooting

Please see "Service" section for a description of each function.

Ice machine disposition	Possible causes	Corrective actions
Legend: ● ON ○ OFF ◐ ON or OFF ✖ FLASHING		
1. Ice machine is in running condition but not making ice. CPU <input checked="" type="radio"/> LO WATER <input type="radio"/> HI WATER <input type="radio"/> DRAIN CLOG <input type="radio"/> HI PRESS <input type="radio"/> HI AMPS <input type="radio"/> SERVICE <input type="radio"/> PURGE <input type="radio"/> CLEANING <input type="radio"/> TIME DELAY <input type="radio"/> REFRIG ON <input checked="" type="radio"/> AUGER ON <input checked="" type="radio"/> LOW BIN <input checked="" type="radio"/> POWER <input checked="" type="radio"/>	1. Defective compressor. 2. Defective start relay. 3. Defective start capacitor. 4. Defective run capacitor. 5. Defective main contactor. 6. No output from PC board.	1. Replace compressor. 2. Replace start relay. 3. Replace start capacitor. 4. Replace run capacitor. 5. Replace main contactor. 6. Replace PC board.
2. The CPU is not flashing. CPU <input checked="" type="radio"/> LO WATER <input type="radio"/> HI WATER <input type="radio"/> DRAIN CLOG <input type="radio"/> HI PRESS <input type="radio"/> HI AMPS <input type="radio"/> SERVICE <input type="radio"/> PURGE <input type="radio"/> CLEANING <input type="radio"/> TIME DELAY <input type="radio"/> REFRIG ON <input checked="" type="radio"/> AUGER ON <input checked="" type="radio"/> LOW BIN <input checked="" type="radio"/> POWER <input checked="" type="radio"/>	1. Processor has been damaged.	1. Replace PC board.
3. Machine in TIME DELAY without full bin. CPU <input checked="" type="radio"/> LO WATER <input type="radio"/> HI WATER <input type="radio"/> DRAIN CLOG <input type="radio"/> HI PRESS <input type="radio"/> HI AMPS <input type="radio"/> SERVICE <input type="radio"/> PURGE <input type="radio"/> CLEANING <input type="radio"/> TIME DELAY <input checked="" type="radio"/> REFRIG ON <input type="radio"/> AUGER ON <input type="radio"/> LOW BIN <input checked="" type="radio"/> POWER <input checked="" type="radio"/>	1. Ice jamming due to improperly installed transport tube causing a false shuttle. 2. Shuttle stuck in up position. 3. Damaged or improperly installed thermostat (open). 4. Transport tube backed-out of coupling.	1. Correct transport tube routing. 2. Repair or replace shuttle mechanism. 3. Replace or reposition thermostat. 4. Correct coupling installation.
4. Ice machine is not making ice. Locked in PURGE. CPU <input checked="" type="radio"/> LO WATER <input type="radio"/> HI WATER <input type="radio"/> DRAIN CLOG <input type="radio"/> HI PRESS <input type="radio"/> HI AMPS <input type="radio"/> SERVICE <input type="radio"/> PURGE <input checked="" type="radio"/> CLEANING <input type="radio"/> TIME DELAY <input type="radio"/> REFRIG ON <input type="radio"/> AUGER ON <input type="radio"/> LOW BIN <input checked="" type="radio"/> POWER <input checked="" type="radio"/>	1. A self-flush occurred but could not drain evaporator due to a failed drain solenoid valve. 2. A self-flush occurred but could not drain evaporator due to water reservoir or ice machine not being level.	1. Replace drain solenoid valve. 2. Level ice machine. Check water reservoir to make sure it is not tilted towards the compressor.
5. Ice machine is not making ice. HI AMPS. CPU <input checked="" type="radio"/> LO WATER <input type="radio"/> HI WATER <input type="radio"/> DRAIN CLOG <input type="radio"/> HI PRESS <input type="radio"/> HI AMPS <input checked="" type="radio"/> SERVICE <input checked="" type="radio"/> PURGE <input type="radio"/> CLEANING <input type="radio"/> TIME DELAY <input type="radio"/> REFRIG ON <input type="radio"/> AUGER ON <input type="radio"/> LOW BIN <input checked="" type="radio"/> POWER <input checked="" type="radio"/>	1. Poor water quality causing ice to jam auger. 2. Damaged shuttle mechanism or thermostat (closed). 3. Kinked transport tube (thermostat systems). 4. Intermittent drive output from PC board. Evaporator will freeze causing a hi amps error. 5. Gearmotor is unplugged.	1. Clean ice machine. Increase flushing frequency. 2. Replace or repair shuttle mechanism/thermostat. 3. Straighten transport tube. 4. Replace PC board. 5. Plug in gearmotor. <i>(see page 15 for "no current" details)</i>
6. Ice machine is not making ice. HI PRESSURE. CPU <input checked="" type="radio"/> LO WATER <input type="radio"/> HI WATER <input type="radio"/> DRAIN CLOG <input type="radio"/> HI PRESS <input checked="" type="radio"/> HI AMPS <input checked="" type="radio"/> SERVICE <input checked="" type="radio"/> PURGE <input type="radio"/> CLEANING <input type="radio"/> TIME DELAY <input type="radio"/> REFRIG ON <input type="radio"/> AUGER ON <input type="radio"/> LOW BIN <input checked="" type="radio"/> POWER <input checked="" type="radio"/>	1. High ambient temperatures >100 F (38 C). 2. Poor ventilation or air recirculation. 3. Clogged condenser. 4. Fan not working properly. No air flow. <ul style="list-style-type: none"> • Blocked fan blades • No fan output from PC board • Faulty fan motor 	1. Air condition area to below 100 F (38 C). 2. Reposition ice machine or properly ventilate. Prevent ice machine exhaust from recirculating. 3. Clean condenser grille. 4. Correct air flow. <ul style="list-style-type: none"> • Remove any blockage from fan blades • Replace PC board • Replace fan motor

Ice machine disposition	Possible causes	Corrective actions
-------------------------	-----------------	--------------------

Legend: ● ON ○ OFF ◐ ON or OFF ✖ FLASHING

<p>7. Ice machine is not making ice. Drain clog.</p>	<p>1. Drain hose kinked or plugged causing water to back up. 2. Improper floor drain routing/pitch causing water to back up. 3. High TDS levels and leaking drain solenoid may cause an errant drain clog.</p>	<p>1. Remove kink or blockage from drain hose. 2. Re-route floor drain. 3. Clean area around drain sensor and/or replace Drain solenoid valve.</p>
<p>CPU <input checked="" type="radio"/> LO WATER <input type="radio"/> HI WATER <input type="radio"/> DRAIN CLOG <input checked="" type="radio"/> HI PRESS <input type="radio"/> HI AMPS <input type="radio"/> SERVICE <input checked="" type="radio"/> PURGE <input type="radio"/> CLEANING <input type="radio"/> TIME DELAY <input type="radio"/> REFRIG ON <input type="radio"/> AUGER ON <input type="radio"/> LOW BIN <input type="radio"/> POWER <input checked="" type="radio"/></p>		
<p>8. Ice machine is making ice. Excessive water in bin or coming into bin from transport tube.</p>	<p>1. Failed water sensors. Processor assumes there is no water when there is water. 2. Blocked reservoir vent. 3. Defective water feed solenoid valve. Stuck in open position.</p>	<p>1. Clean or replace water probe assembly. Check wiring connections. 2. Clean or replace vent tubes. 3. Replace water feed solenoid valve.</p>
<p>CPU <input checked="" type="radio"/> LO WATER <input type="radio"/> HI WATER <input type="radio"/> DRAIN CLOG <input type="radio"/> HI PRESS <input type="radio"/> HI AMPS <input type="radio"/> SERVICE <input type="radio"/> PURGE <input type="radio"/> CLEANING <input type="radio"/> TIME DELAY <input type="radio"/> REFRIG ON <input checked="" type="radio"/> AUGER ON <input checked="" type="radio"/> LOW BIN <input checked="" type="radio"/> POWER <input checked="" type="radio"/></p>		
<p>9. Ice machine is not making ice. Lo water.</p>	<p>1. Water supply is turned off. 2. Low water pressure. 3. Defective water feed solenoid valve. Stuck in closed position. 4. No water feed output from PC board.</p>	<p>1. Turn water supply on. If evaporator was completely empty the reset button may have to be pressed to restart the ice machine. 2. Ice machine will eventually start when water reaches normal lo level. 3. Replace water feed solenoid valve. 4. Replace PC board.</p>
<p>CPU <input checked="" type="radio"/> LO WATER <input checked="" type="radio"/> HI WATER <input type="radio"/> DRAIN CLOG <input type="radio"/> HI PRESS <input type="radio"/> HI AMPS <input type="radio"/> SERVICE <input checked="" type="radio"/> PURGE <input type="radio"/> CLEANING <input type="radio"/> TIME DELAY <input type="radio"/> REFRIG ON <input type="radio"/> AUGER ON <input type="radio"/> LOW BIN <input checked="" type="radio"/> POWER <input checked="" type="radio"/></p>		

Replacement parts

Order parts online
www.follettice.com

Evaporator assembly

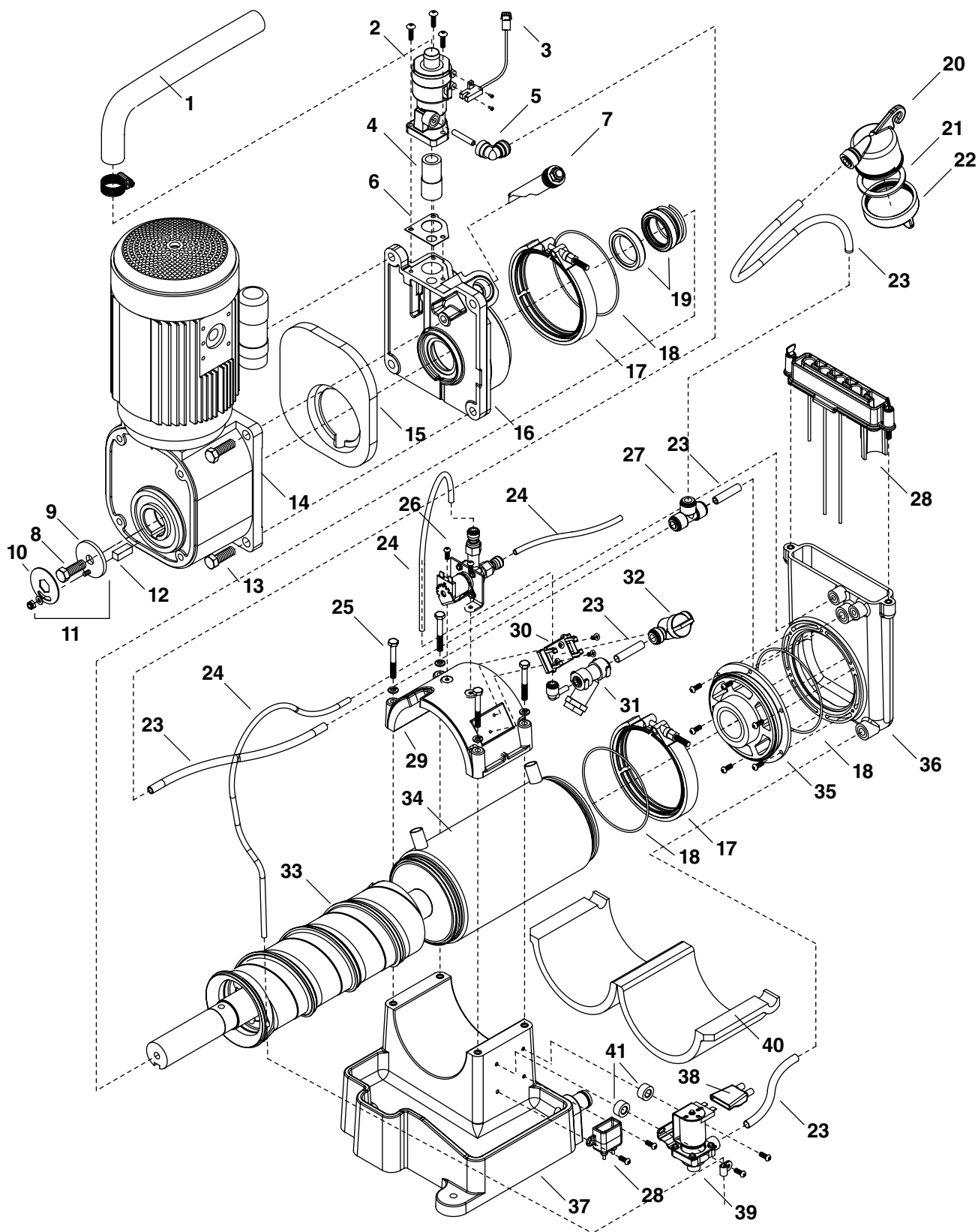

Reference #	Description	Part #
1	Tube, ice transport, molded	00175299
2	Shuttle assembly (includes 00115600 & 0013066)	00130815
3	Switch, optical	00130849
4	Compression nozzle	00115774
4	Compression nozzle, MINI Chewblet (not for use with mechanical dispensers)	00136986
5	Elbow, water	00134502
6	Gasket, shuttle	00115600
7	Stream divider	00142513
8	Auger bolt	00116988
9	Washer	00161513
10	Retainer, auger bolt	00161356
11	Kit, auger bolt (auger bolt, washer, retainer, nut and washer)	00161406
12	Key	00117804
13	Bolts, gearmotor mounting (4)	00130641
14	Gearmotor, 240V (includes capacitor)	00130807
15	Gasket, gearmotor	00121632
16	Main housing (includes 00112946 & 00116962)	00142539
17	Coupling, V-band	00130708
18	O ring	00116962
19	Seal, auger shaft	00112946
20	Cup, sanitizer	00130674
21	Gasket, sanitizer	00124032
22	Cap, sanitizer (includes 00124032)	00130880
23	Tubing, water, 3/8" OD	502719
24	Tubing, water, 1/4" OD	502079
25	Hardware, mounting, evaporator cap	00130989
26	Solenoid, water feed (240V)	00130831
27	Tee, water	00134494
28	Sensor assembly, water level and drain clog	00171363
29	Cap, evaporator (includes 00125468 & 00130989)	00130740
30	Clip, water shut-off valve	502922
31	Strainer, water	502920
32	Valve, shut-off, water	502921
33	Auger (includes 00112946 & 00116962)	00945717
34	Evaporator (includes 00112946, (2) 00116962 & 0012116)	00130724
35	Journal housing and bearing (includes (2) 00116962)	00130716
36	Reservoir, water	00130690
37	Base, evaporator	00130732
38	Boot, solenoid	00160309
39	Solenoid, purge (240V)	00130765
40	Insulation, evaporator	00121616
41	Spacers, solenoid	00160317
Not shown	Insulation, evaporator cap	00125468
Not shown	Condensate pan	00161612

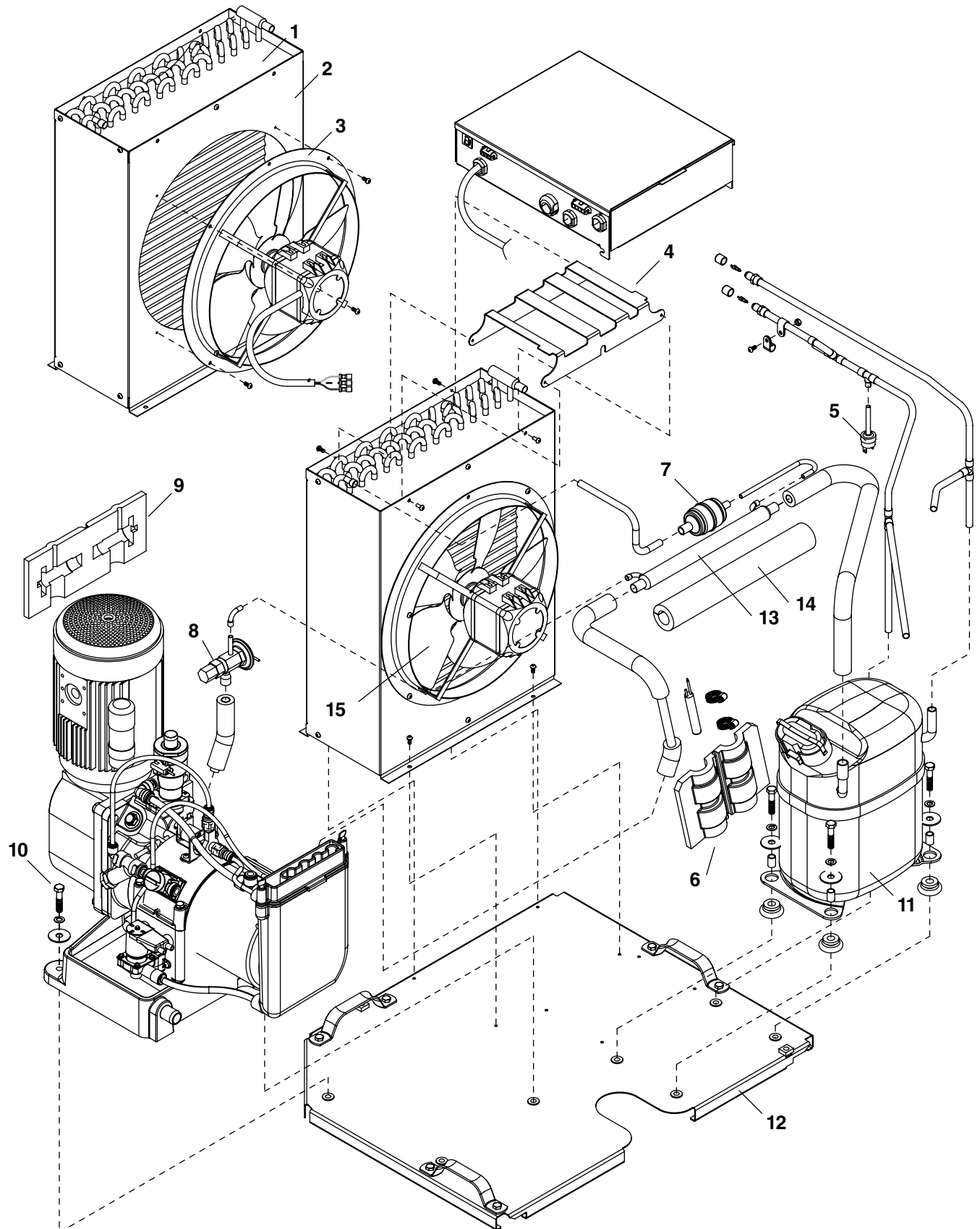

Reference #	Description	Part #
1	Condenser (includes 00130922)	00130914
2	Shroud, condenser	00130922
3	Fan motor assembly	00130930
4	Electrical box support	00156035
5	Cut-out, high pressure safety	00117077
6	Insulation, bulb, TXV	00106534
7	Drier	502724
8	Valve, expansion, thermal (includes 502830 and 00106534)	00130997
9	Insulation, TXV	502830
10	Hardware, evaporator mounting base (set of four)	00130971
11	Compressor	00121582
12	Base, icemaker	00130856
13	Heat exchanger (includes 00172361)	00172353
14	Heat exchanger insulation	00172361
15	Fan blade	00170290

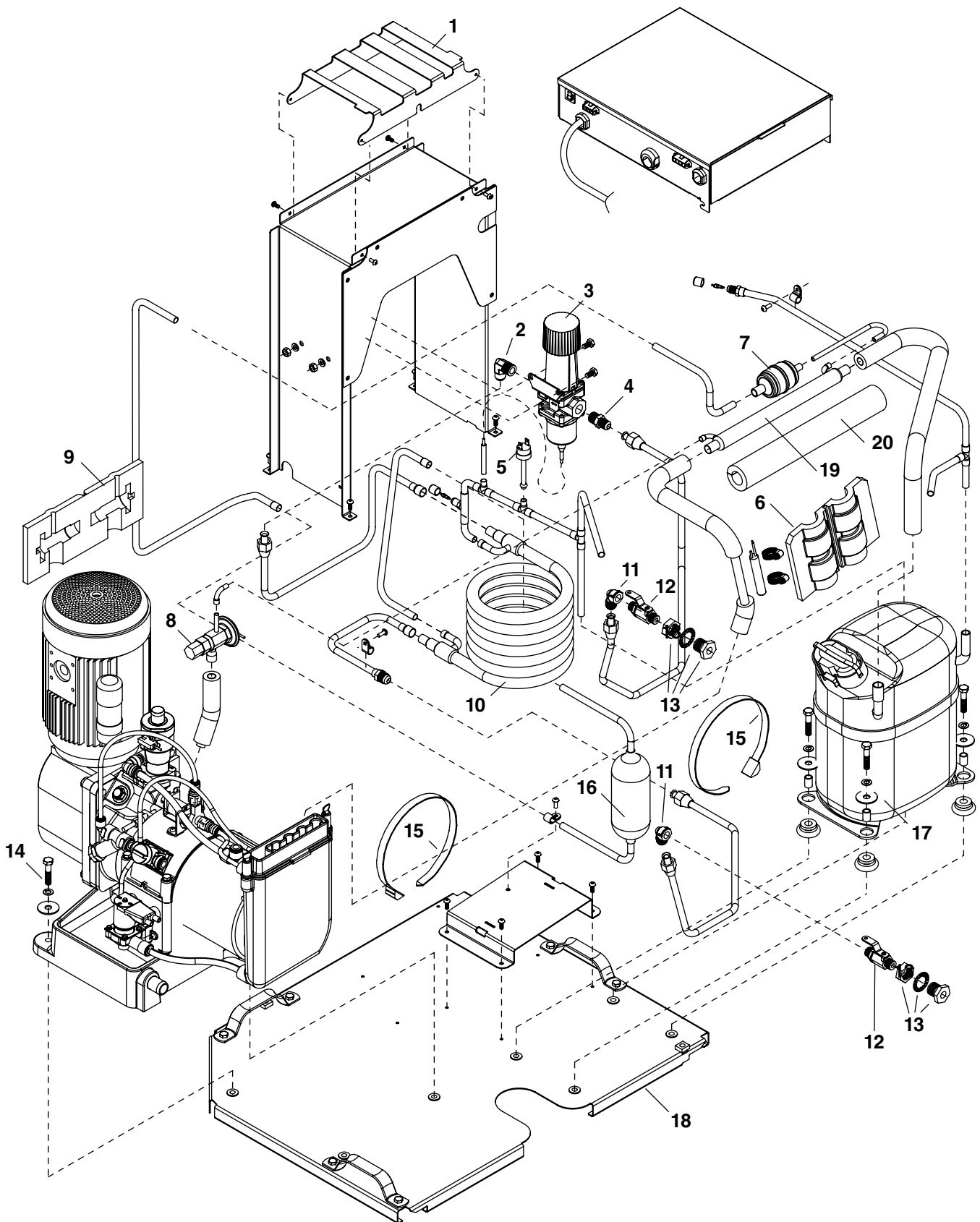

Reference #	Description	Part #
1	Electrical box support	00156035
2	Elbow, water	00129486
3	Valve, water regulating	00131052
4	Union, water	202148
5	Cut-out, high pressure safety	00117077
6	Insulation, bulb, TXV	00106534
7	Drier	502724
8	Valve, expansion, thermal (includes 502830 and 00106534)	00130997
9	Insulation, TXV	502830
10	Condenser, w/c	00117234
11	Elbow, water, 90°	00129478
12	Valve, shut-off, water	502222
13	Coupling	206411
14	Hardware, evaporator mounting base	00130971
15	Ty-rap	204584
16	Receiver	00123109
17	Compressor	00121582
18	Base, icemaker	00130856
19	Heat exchanger (includes 00172361)	00172353
20	Heat exchanger insulation	00172361

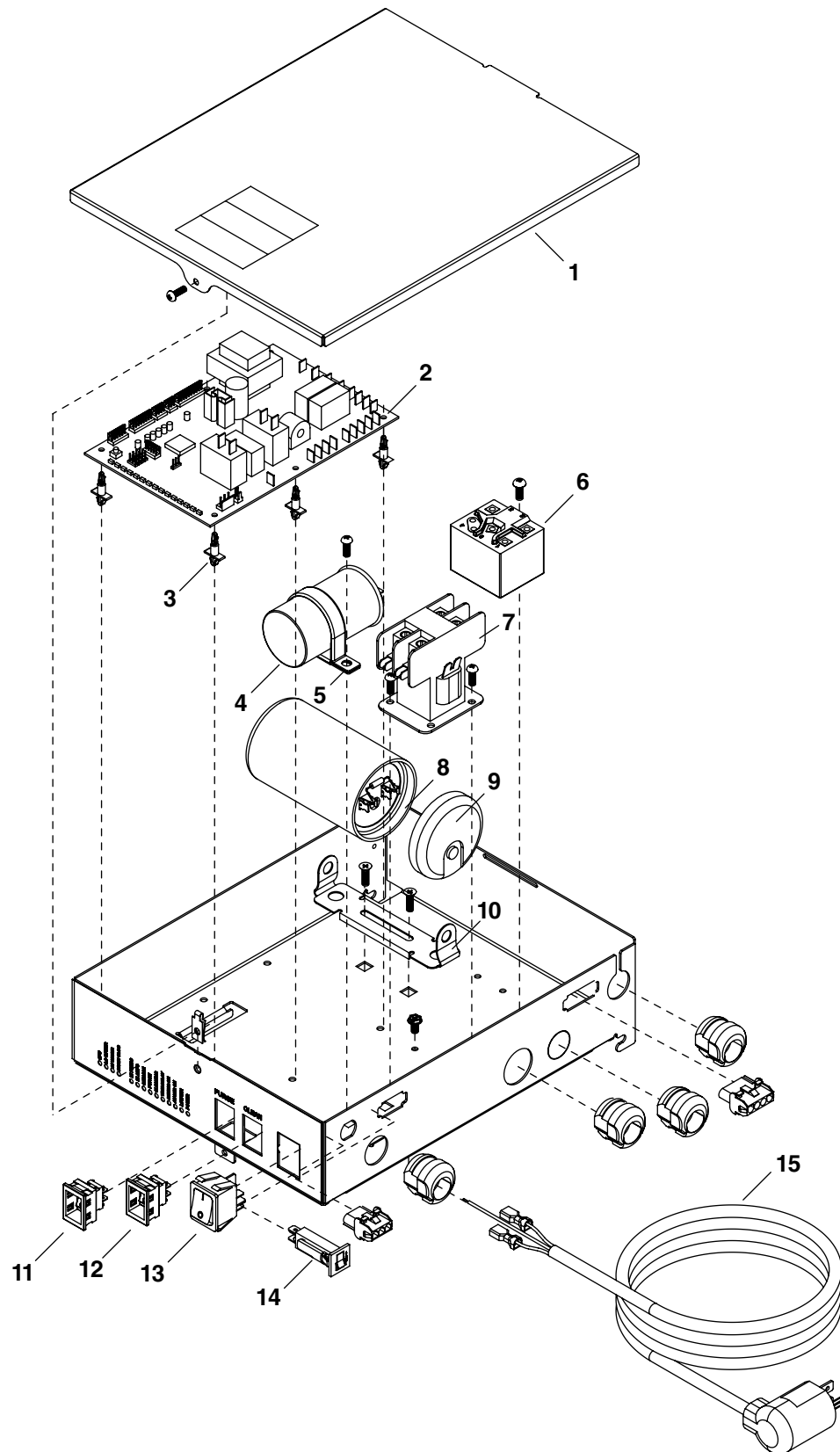

Reference #	Description	Part #
1	Cover, electrical box, air/water-cooled	00130872
2	Board, control circuit, 240V (includes 00130906)	00132902
3	Stand off's (set of 6)	00130906
4	Capacitor, compressor run	00133512
5	Clamp, run capacitor	00133603
6	Relay, compressor starting (includes wire harness)	00161810
7	Contactora	00917195
8	Capacitor, compressor starting	00133504
9	Cap, capacitor	00133587
10	Bracket, capacitor	207625
11	Switch, evaporator purge	00114371
12	Switch, evaporator clean	00117036
13	Switch, icemaker power	208867
14	Circuit breaker, 4 amp	00126912
15	Cord, power, 240V	00192096

Top mount configuration

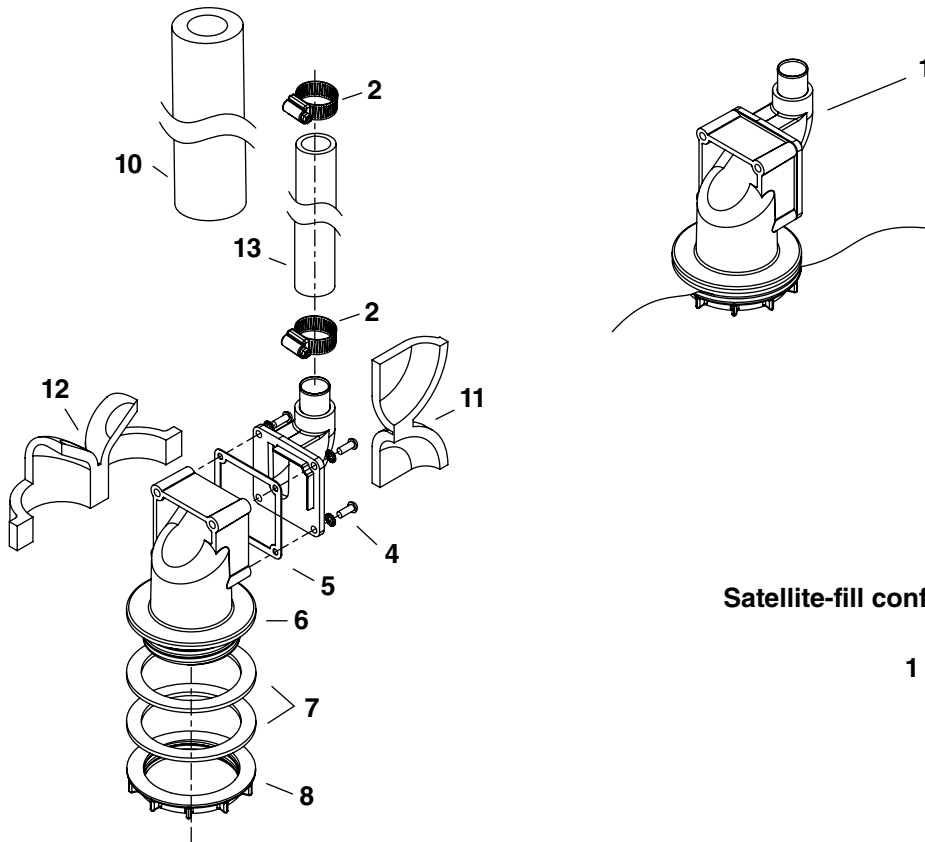

Satellite-fill configuration

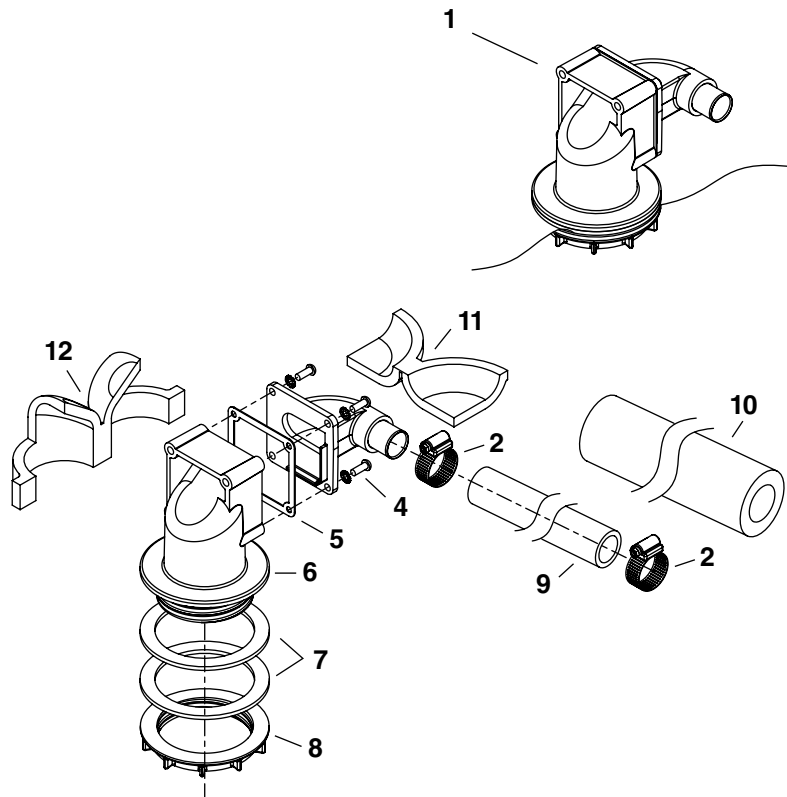

Reference #	Description	Part #
1	Shuttle actuator	00171322
2	Clamp	500377
3	Actuator elbow (includes 00167122 and 209100)	00171264
4	Screws	209100
5	Gasket	00167122
6	Actuator body	00171272
7	Gasket, coupling	00126532
8	Ring, locking (includes 00126532)	00171371
9	Ice transport tube, 10' (3m)	00171280
9	Ice transport tube, 20' (6m)	00171298
10	Insulation, transport tube	501176
11	Insulation, elbow	00168922
12	Insulation, actuator	00168930
13	Ice transport tube, top mount, 30" (762mm)	00171306
Not shown	Integration kit, top mount	00171389
Not shown	Integration kit, Satellite-fill (requires transport tube)	00171397
Not shown	Extension-fill tube, 9"	00135723
Not shown	Extension-fill tube, 4"	00153684
Not shown	Follett SafeCLEAN ice machine cleaner (case of 24 x 7oz packets)	00132001
Not shown	Sani-Sponge kit	00132068

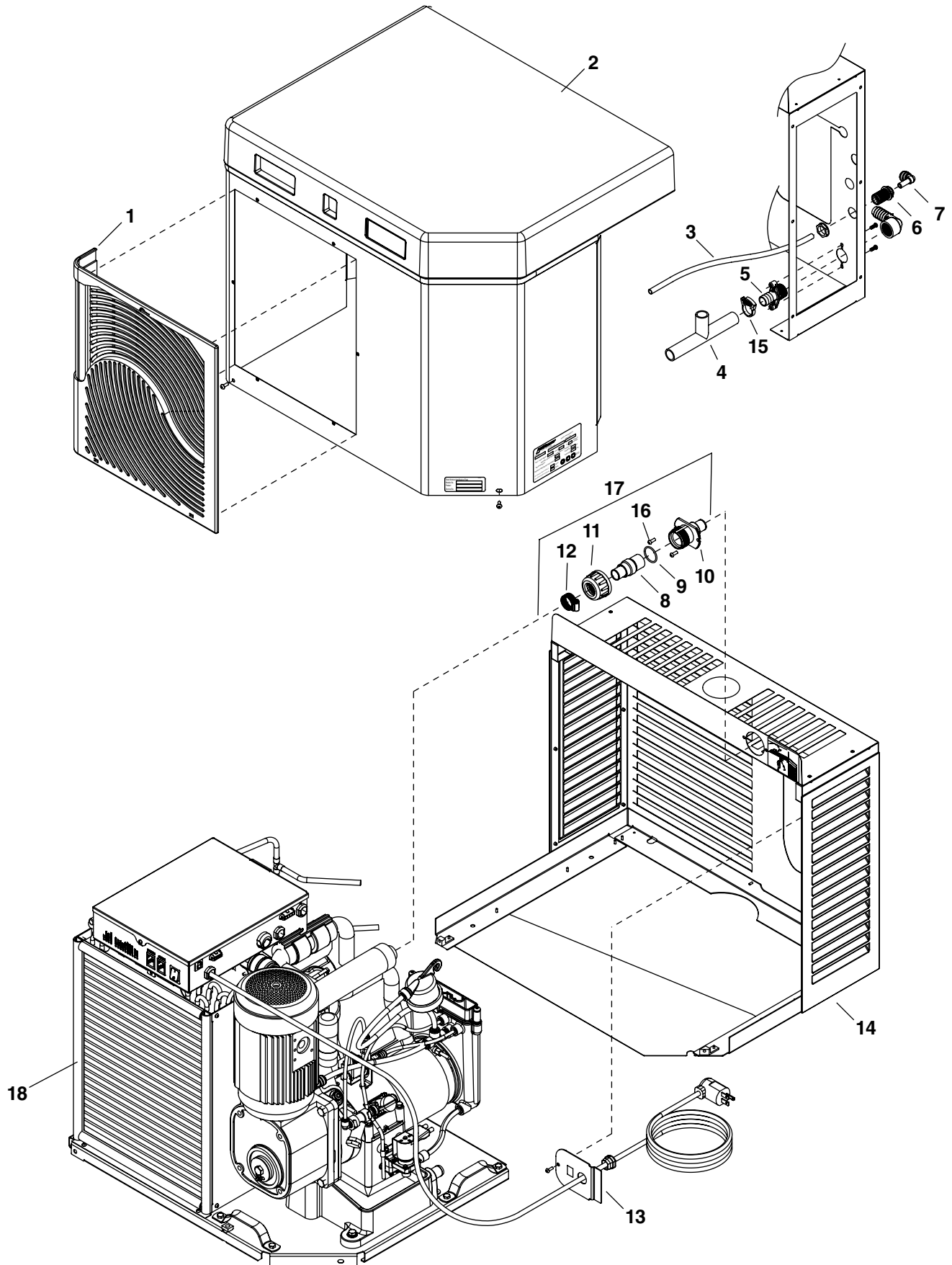

Reference #	Description	Part #
1	Grille, intake	00122846
2	Front cover, air- & water-cooled (includes 00122846)	00130625
3	Tubing, water, 1/4" OD	502719
4	Tubing, drain	00144923
5	Fitting, drain	00109728
6	Fitting, water inlet	502924
7	Elbow, water inlet	502925
8	Coupling (includes 00144675)	00171207
9	O ring	00144675
10	Bulkhead fitting	00171215
11	Nut	00145342
12	Hose clamp	500377
13	Plate, strain relief	00192070
14	Louvered docking assembly (includes reference #'s 3, 4, 5, 6, 7, 10, 13, 15, 16)	00130658
15	Clamp, drain line	00114520
16	Screws	208568
17	Bulkhead connector kit	00171223
18	Gasket, condenser	00135574
Not Shown	Louver, intake/exhaust (13.75"x17.75")	00128066
Not Shown	Gasket, air intake	00913582

Horizon, Harmony, Ice Manager, SafeCLEAN, Sani-Sponge, Satellite-fill and Vision are trademarks of Follett Corporation.
Chewblet is a registered trademark of Follett Corporation, registered in the US.



801 Church Lane • Easton, PA 18040, USA
Toll free (800) 523-9361 • (610) 252-7301
Fax (610) 250-0696 • www.follettice.com



00171579R06
03/09