

REF5-BB

Undercounter Blood Bank Refrigerator

Order parts online
www.follettice.com

Installation, Operation and Service Manual

Serial numbers C45184 and above

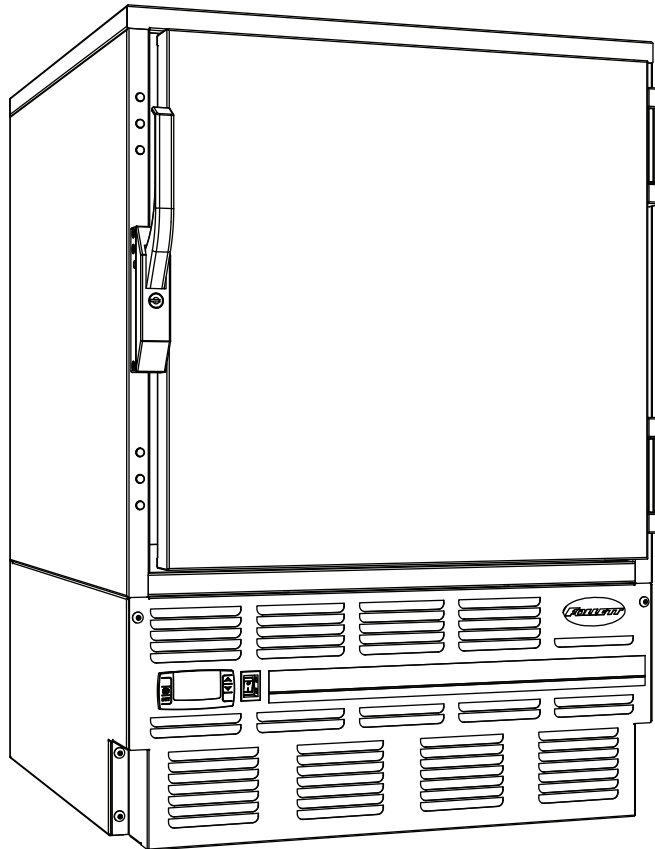

**Following installation, please forward this manual
to the appropriate operations person.**

Welcome to Follett

Follett equipment enjoys a well-deserved reputation for excellent performance, long-term reliability and outstanding after-the-sale support. To ensure that this product delivers that same degree of service, we ask that you take a moment to review this manual before beginning the installation. Should you have any questions or require technical help at any point, please call our technical service group at (800) 523-9361 or (610) 252-7301.

Before you begin

After uncrating and removing all packing material, inspect the equipment for concealed shipping damage. If damage is found, notify the shipper immediately and contact Follett Corporation so that we can help in the filing of a claim, if necessary.

Specifications

REF5-BB

34" height for freestanding use or installation below standard 36" (915mm) high counter

2 drawer – up to 50 (450ml) bags

Maximum drawer load - 35 lbs (16kg) each

Electrical specifications

115V, 60Hz, 1 phase

Full load amps: 8.0

Minimum circuit ampacity: 15 amp

Maximum size of branch circuit overcurrent device: 15 amp

Refrigeration specifications

Refrigerant – R404A

Charge size – 10 oz

Maximum design pressures:

High side – 422psi

Low side – 175psi

Installation specifications

Ambient temperature must not exceed 100 F (38 C).

The front louvered panel must be kept free of any cabinet trim or obstructions to ensure proper ventilation of the refrigeration system.



Important cautions

- **Equipment must be wired according to local and NEC codes.**
- **Always disconnect power before servicing refrigerator.**

Installation

Installing legs – required

1. Remove legs from plastic bag packed inside refrigerator.
2. Tip refrigerator back and screw legs in all the way to stop (they will extend 1/8" below base of refrigerator).
3. Adjust legs as needed to level refrigerator in both directions. To access legs, remove the lower front panel. Turn legs clockwise to extend legs.

Accessory Installation

Temperature Surveillance Module Accessory Materials supplied

- (1) Temperature surveillance module
- (1) 4" stainless probe with 8 ft cable
- (1) Short length of Tygon tubing (for FZR applications only)
- (1) Power supply with 5 ft cord
- (1) Probe bottle with internal gasket and screw-on cap
- (2) Bottle bracket (long and short)
- (1) 9-volt battery
- (1) Box of sixty (60) -50 to +50 7-day charts

1. Set dip switches on back of unit to select recording time, °F/C and supplied chart range (Fig. 2). Switches are easily moved up or down with a pointed object.
2. Remove the protective pen cap.
3. Insert 9V battery in battery compartment and plug in AC adapter. (Fig. 3) Unit will power on.
4. The instrument will move pen to the appropriate readings.
5. Supplied chart installation: -50 to +50 chart (Other scale charts purchased directly from Dickson require alternate dip switch settings. Refer to chart on reverse of unit):
 - a. Press the PEN HOME key (Fig. 4) to move the pen to the outside of the chart. The pen is automatically raised off the chart.
 - b. Remove the old chart, place the new chart on the Chart Hub – being certain that the edge of the chart slides under the Chart Guide Clips located at the outside of the chart.
6. Set the appropriate time. There are two ways to adjust the chart and set the appropriate time:
 - a. Set the chart time manually by inserting a coin into the groove in the chart hub and turning clockwise until the correct hour (and day if applicable) on the chart is referenced to the timing arrow (just to the right of the pen tip on the dial).
 - b. (For fine adjustments only)
 1. To adjust the chart time, press and hold ADJUST-UP and ADJUST-DOWN buttons located on the back of the unit next to the dip switch (Fig. 3).
 2. The green LED will blink rapidly for about five seconds, then the LED will remain solid green
 3. While in this state ADJUST-UP button will move the chart backward (counter clockwise) and ADJUST-DOWN button will move the chart forward (clockwise).
 4. Rotate the chart until the correct hour (and day if applicable) on the chart is referenced to the timing arrow.

Fig. 1

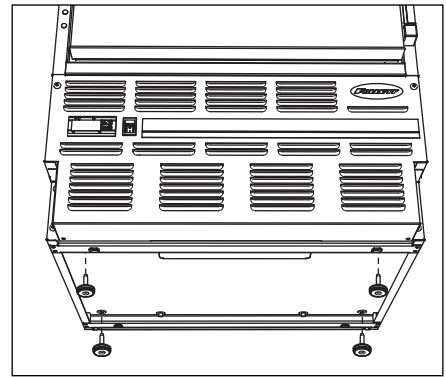

Fig. 2

Feature	Selection	Dip Switch UP	Dip Switch DOWN
Recording time	7 days		#2
	24 hr	#2	
°F/C	°F		#3
	°C	#3	
Chart (supplied)	-50° to +50°	#4	#5, #6

Other chart ranges are available. Consult manual packed with module or reverse of unit. Dip switches 1, 7 and 8 are not active in this recorder.

Fig. 3

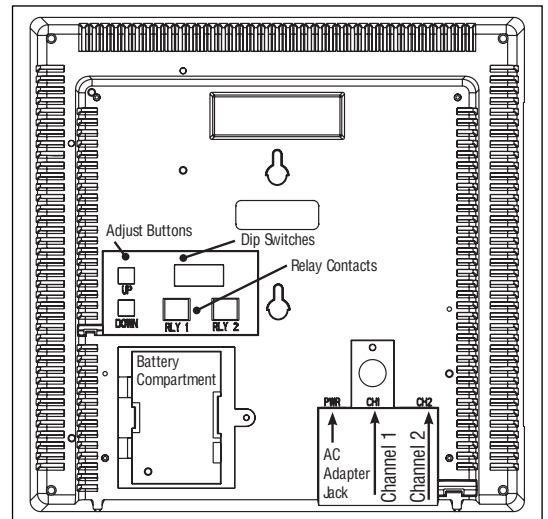
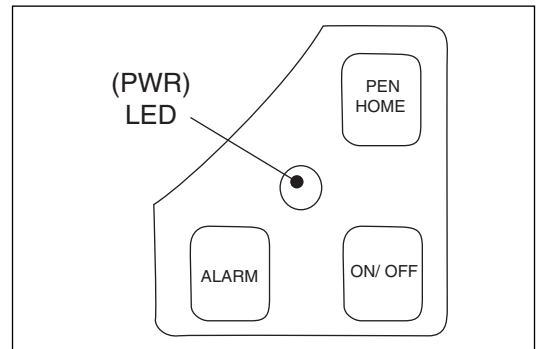

Fig. 4



7. Once you have set your chart, press the PEN HOME button to exit Chart Adjust Mode. The unit will take one minute to exit Chart Adjust Mode once PEN HOME is pressed.
8. Press PEN HOME to move the pen back onto the chart

Caution: Be sure the unit is in a vertical position and level. For best performance and longevity, the location should be a clean environment, free from dust and corrosive fumes. Do not exceed temperature specifications.

Setting Alarm ON/OFF

1. Enter alarm programming mode by pressing and holding alarm button for 5 seconds. LED will light solid red.
2. Turn Alarm ON or OFF with the Adjust Up or Adjust Down buttons located on the back of the unit next to the dip switches.
3. Continue alarm adjustments by adjusting alarm min/max (see below) or press and hold alarm button for 5 seconds to exit alarm programming mode.

Setting Alarm min/max

Note: Alarm must be ON (See Setting Alarm ON/OFF above) to adjust min/max

1. Enter alarm programming mode by pressing and holding alarm button for 5 seconds.
2. Press Pen Home to display minimum. Adjust temperature up or down using the Adjust UP or Adjust Down buttons located on the back of the unit next to the dip switches.
3. Press Pen Home again to display maximum. Adjust temperature up or down using the Adjust UP or Adjust Down buttons located on the back of the unit next to the dip switches.
4. Exit alarm programming mode by pressing and holding alarm button for 5 seconds.

Probe, bottle and bracket installation (not required for REF5-BB, FZR5-PL)

FZR4-ADA and FZR5 freezers only

- a. Use flat-head screwdriver to open small knock-out in upper left corner of back wall inside cabinet (Fig. 5.1).
- b. Insert 1/2" of probe end into supplied Tygon tubing.
- c. From cabinet back, push open end of tubing through refrigerant port and knock-out hole.
- d. Remove Tygon tube from probe end and discard tubing.

REF4-ADA and REF5 refrigerators only

- a. Route probe through grommeted hole in back of refrigerator where refrigeration lines enter the cabinet.

All models

- a. Install probe bracket: Press center tab of short bottle bracket into top of front left pilaster (Fig. 5.2). **Note:** It may be necessary to use longer bottle bracket if shelf is positioned at very top of cabinet.
- b. Fill bottle with solution used at your facility to increase accuracy of readings by simulating the internal temperature of stored product.
- c. Push probe down through gasketed bottle top and insert into bottle bracket.

Fig. 5

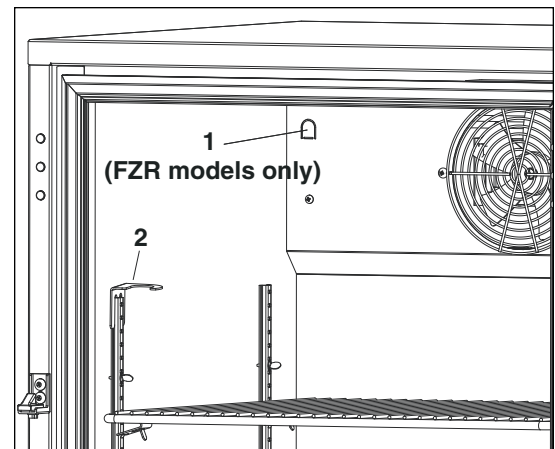

Alarm relays

The SPST 24V 500mA relay contacts, located on the back of the recorder, are normally open and will close on alarm conditions when the alarms are enabled. Relay contacts are always functional when the alarm is enabled. The relay will close only during minimum and maximum alarm conditions.

Mounting recorder

Place the chart recorder on a flat vibration-free surface or mount it on wall using keyhole slots on back.

Replacement charts (item #00162099) and replacement pens (item #00162081) can be ordered from Follett by calling Technical Service at 800-523-9361.

Temperature Alarm Accessory for REF and FZR Series

Materials supplied

- (1) Alarm module
- (1) 4" stainless probe with 8 ft cable
- (1) Short length of Tygon tubing (for FZR applications only)
- (1) Power supply with 5 ft cord
- (1) Probe bottle with internal gasket and screw-on cap
- (2) Bottle bracket (long and short)
- (1) 9-volt battery

Procedure

1. Remove 2 screws from module face and remove faceplate.
2. Install 9-volt back-up battery.
3. Locate DIP switches on the back of the faceplate (Fig. 6).
4. Review the factory DIP switch settings (Fig. 7) and make any changes required to meet the needs of your specific application.
5. Reinstall faceplate.

Fig. 6

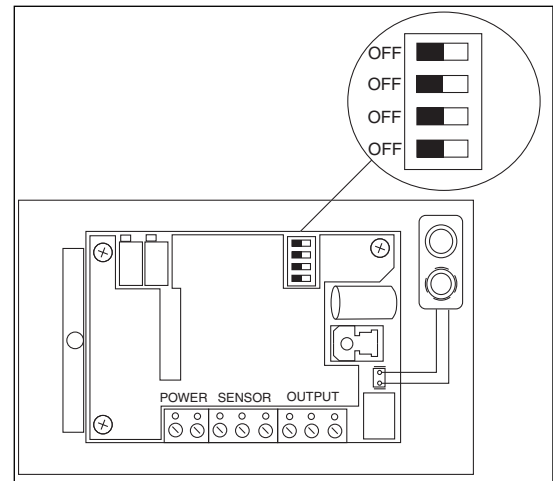

Fig. 7

Dip Switch	OFF (factory default setting)	ON
1	No alarm delay	45 minute alarm delay
2	Auto reset (alarm stops automatically as soon as temperature returns to set range)	Manual reset of alarm (user must press RESET button to stop audible alarm even if temperature has returned to set range)
3 & 4	Audible alarm on (no snooze with both off)	No audible alarm
3	Enables 5 min alarm "snooze" when reset button is pressed (3 off with 4 on)	Enables 45 min alarm "snooze" when reset button is pressed (3 on with 4 off)

Installing alarm

1. Mount alarm in desired location with screws (supplied by others) through back of housing. Do not place undue strain on probe cable.

Note: Do not modify length of probe wire. Probe will not measure temperature correctly if wire length is changed.
2. Plug power cord into 110 outlet.
3. Push center tab of short bottle bracket into top of front left pilaster (Fig. 8.1).

Note: It may be necessary to use longer bottle bracket if shelf is positioned at very top of cabinet.
4. Fill bottle with solution used at your facility (e.g. 50/50 propyleneglycol/water solution) to increase accuracy of readings by simulating the internal temperature of stored product.

Fig. 8

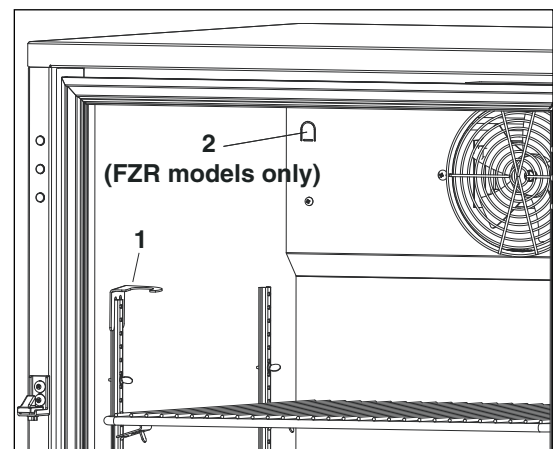

5. Insert bottle into bottle bracket.
6. **FZR4-ADA and FZR5 freezers only**
 - a. Use flat-head screwdriver to open small knock-out in upper left corner of back wall inside cabinet (Fig. 8.2).
 - b. Insert 1/2" of probe end into supplied Tygon tubing.
 - c. From cabinet back, push open end of tubing through refrigerant port and knock-out hole.
 - d. Remove Tygon tube from probe end and discard tubing.
7. **REF4-ADA and REF5 refrigerators only**
 - a. Route probe through grommited hole in back of refrigerator where refrigeration lines enter the cabinet.
8. **All models**
 - a. Push probe down through gasketed bottle top and insert into bottle bracket.

Note: Alarm probe must be placed in bottle for proper system operation. Refer to Fig. 9 if attaching alarm to central monitoring or central alarm system. A SDPT 1 amp 24V AC resistive relay is provided for this connection.

Setting alarm temperatures

1. After the installation is complete, allow 30 minutes for the system to stabilize to ambient temperature.
 2. Calibrate temperature alarm to refrigerator display
 - a. Calibration is best done with the alarm probe removed from the probe bottle and placed in the vicinity of the temperature controller probe. Allow at least 15 minutes for the probe temperature to stabilize.
 - b. Note the temperature value displayed on the refrigerator controller and subtract the temperature value displayed on the alarm. This value is the differential.
- Example:** Temperature controller: 36°F Alarm: 38°F
 Controller – Alarm = Differential 36 – 38 = -2
- c. Press and release SET repeatedly until "CAL" is displayed (Fig. 10.1).
 - d. Press SET again to display "CAL" value (Fig. 10.1).
 - e. Press top or bottom of ADJUST arrow to display the calculated differential (-2°F in example above).
3. Set high alarm limit
 - a. Press and release SET repeatedly until "HSP" is displayed (Fig. 10.1).
 - b. Press SET again to display HSP value (Fig. 10.1).
 - c. Press top or bottom of ADJUST arrow until desired HSP value is displayed (Fig. 10.2).
 4. Set low alarm limit
 - a. Press and release SET repeatedly until "LSP" is displayed (Fig. 10.1).
 - b. Press SET again to display LSP value (Fig. 10.1).
 - c. Press top or bottom of ADJUST arrow until desired LSP value is displayed (Fig 10.2).
 5. Display will return to temperature display in approximately 15 seconds.
 6. Place probe back in probe bottle.

Fig. 9

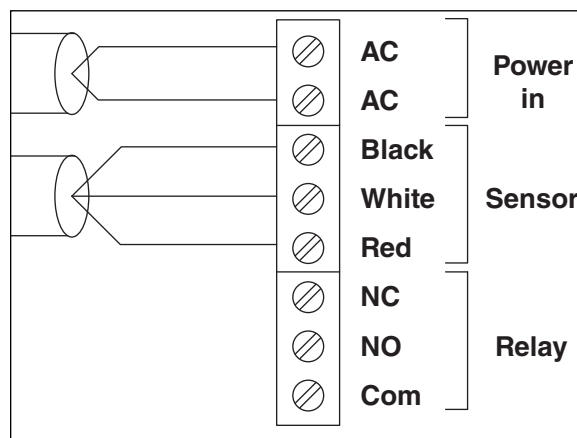
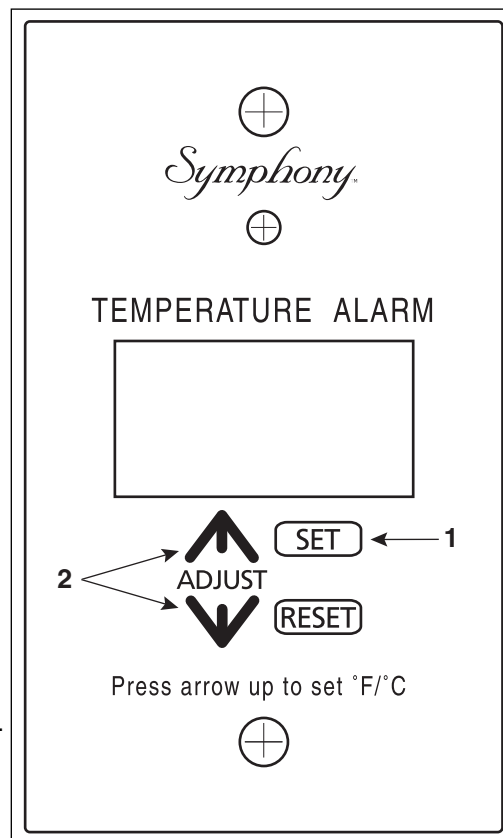

Fig. 10



Viewing high/low log

Follett's alarm module allows users to view the highest and lowest temperatures recorded since the last time the RESET button was pressed.

To view high and low log values

1. Press SET button until "HI" appears.
2. Press SET button to view HI log value.
3. Press SET button until "LOW" appears.
4. Press SET button to view low log value.
5. Press RESET button to clear log.

Alarm operation facts

The back-up battery will continue to provide alarm protection during power failure but will alarm ONLY if temperatures go out of the selected range. During power failure the alarm face will be dark but temperatures can be read by pressing the RESET button.

Low battery is indicated by 3 decimal points in temperature display (3.6.f.).

To see the highest or lowest temperature since last reset, press the button until "HI" or "LOW" appears. To clear log value, press RESET.

Because the temperature alarm display simulates the true temperature of stored medications rather than the air temperature inside the refrigerator, we suggest that staff refer to the alarm display to log temperatures for JCAHO compliance.

Automated medication dispensing and inventory systems interface

(Pyxis, Omnicell*, MedSelect*, etc.)*

Follett refrigerators and freezers are compatible with most major automatic medication and inventory systems. In some cases a Follett bracket accessory is required. Contact factory for further information.

*

Pyxis is a registered trademark of Cardinal Health in the United States and other countries.

Omnicell is a registered trademark of Omnicell, Inc. in the United States.

MedSelect is a registered trademark of AmerisourceBergen Technology Group, in the United States.

Reversing the door swing – optional

NOTICE

When reinstalling latch and hinge screws, 242 blue Loctite* MUST be applied to screws. Torque screws to 25 in-lbs.

1. Remove screws and latch from refrigerator cabinet (Fig. 11.1).
2. Use flat screwdriver to carefully remove (do not scratch) hinge covers (Fig. 12.1).
3. Support door and remove screws attaching hinge to refrigerator cabinet (Fig. 12.2).
4. Cover hinge screw holes with screw hole plugs removed from opposite side.
5. Reverse door. Apply 242 blue Loctite to hinge screws and reinstall torqued to 25 in-lbs.
6. Reinstall latch on opposite side.
7. Remove screws and handle from door (Fig. 13.1).
8. Rotate handle (Fig. 13.2).
9. Apply 242 blue Loctite to latch screws and reinstall torqued to 25 in-lbs.

Note: See keypad lock manual for reversing a door that is equipped with a keypad lock.

Fig. 11

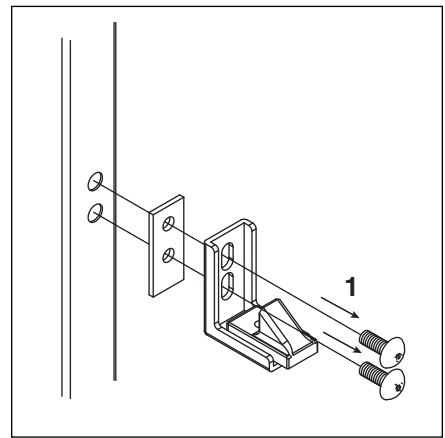

Fig. 12

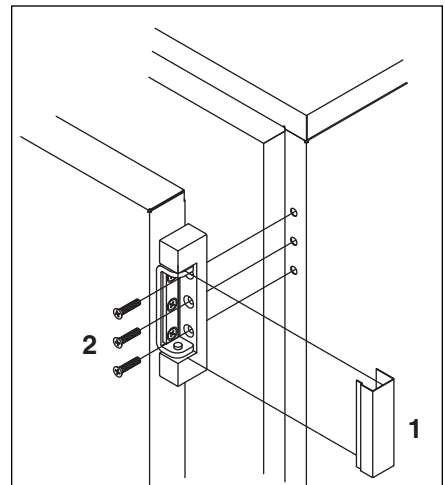
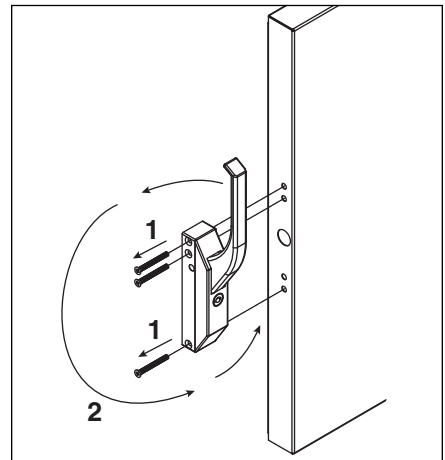

Fig. 13



* Loctite is a registered trademark of Henkel Corporation in the United States and other countries.

Controller operation

In normal operation the controller displays cabinet temperatures in degrees C (default) or user-selected degrees F. Degrees C temperatures are displayed to 1 decimal point.

The controller is pre-programmed with a +3.5 C (+38 F) set point which provides a compressor cut-in at +3.5 C (+38 F) and cut-out at +5.0 C (+41 F).

All set points have a 1.5 C differential. The 1.5 C differential means that with a +3.5 C set point, for example, the compressor will turn off at +3.5 C (+38 F) and turn on when the cabinet temperature reaches +5 C (+41 F).

This temperature may not reflect the temperature of the blood products in the refrigerator. The temperature of the blood products will be reflected on the recorder chart and the recorder's digital temperature display. At times there may be a difference between the two displayed temperatures. Adjust the controller SET value to achieve your desired blood product temperature as displayed on your chart recorder.

Fig. 14

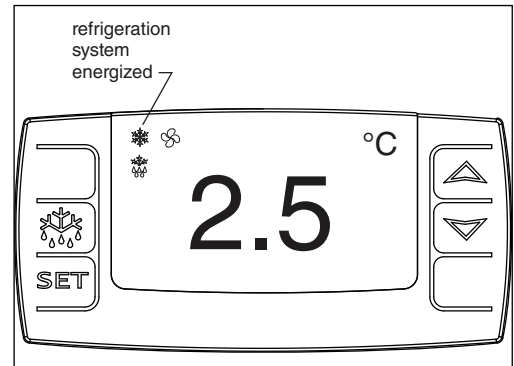

To display temperature cut-out

STEP	INPUT	DISPLAY
1	Press and release SET	Current cut-out temperature will display for approximately 5 seconds. Display will return to current refrigerator temperature.

To change temperature cut-out

STEP	INPUT	DISPLAY
1	Press and hold SET for 3 seconds	Current cut-out temperature displayed and °C will flash
2	Press UP or DOWN arrows to desired cut-out temperature	New cut-out temperature displayed
3	Press and release SET	New cut-out temperature blinks three times, then current refrigerator temperature will display

Refer to the chart below for the set point for your application's required temperature range.

SET POINT DEGREES C	CUT-IN DEGREES C	CUT-OUT DEGREES C	NORMAL DISPLAY RANGE DEGREES C
+3.5 C	+5.0 C	+3.5 C	1.5 to 5.0 C

Controller security

The controller panel can be locked to prevent inadvertent or intentional programming changes. In locked mode, the controller will display cabinet temperature and cut-out set point only.

To lock the controller

1. Press the UP and DOWN ARROW buttons together for 3 seconds until “PoF” displays (will flash 3 times).
2. Programmer is now locked.

To unlock the controller

1. Press UP and DOWN ARROW buttons together for 3 seconds until “Pon” displays (will flash 3 times).
2. Programmer is now unlocked.

Controller programmer key (optional accessory)

A controller programming key is available from Follett to provide fast and easy re-programming of factory settings. Programming key part number is 00183335.

Programming refrigerator from the programming key (download)

1. TURN OFF refrigerator.
2. Remove 6 screws from front panel to access back of controller.
3. Insert programming key into 5 PIN receptacle on controller back.
4. TURN ON refrigerator.
5. Values from key automatically download to refrigerator (“do!” message blinks followed by “end”).
6. After 10 seconds display returns to current refrigerator temperature and controller will restart with new values.
7. TURN OFF.
8. Remove key.
9. Reinstall panel.

Note: An “Err” message displays for failed programming. Turn refrigerator OFF then ON to restart download, or remove key to abort.

Fig. 15

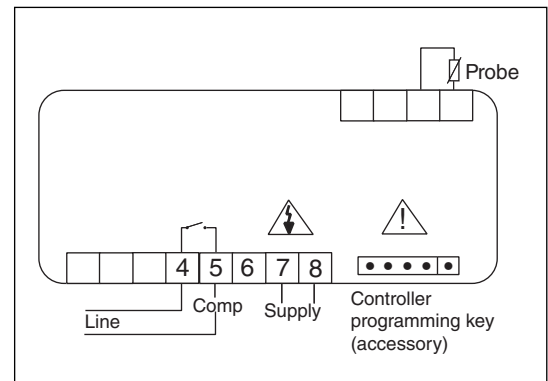

Operation

The temperature controller and probe indicate when the refrigeration system is required to turn on and off.

The refrigeration system removes heat from the cabinet interior and rejects it to the surrounding room air. When the cabinet interior temperature reaches +1.5 C above the controller set point, the probe signals the controller to turn the refrigeration system on. The normally open controller contacts close and energize the condenser fan motor and compressor. The compressor uses a current-style starting relay and a starting capacitor to start the compressor motor.

When the cabinet interior temperature falls to the set point, the probe signals the controller to turn the refrigeration system off. The controller contacts reopen, which de-energizes the condenser fan motor and the compressor. The evaporator fan motor runs continuously.

Any accumulated frost on the evaporator coils melts during the off cycle. The condensate drains to a drain pan mounted alongside the condensing unit. The heat from the condensing unit evaporates any condensate in the drain pan.

Temperature control

The temperature control system is preset by the factory to maintain a cabinet temperature of +3.5 C to +5 C (+38 F to +41 F). If desired, the cut-out temperature can be raised as high as +6°C by following the instructions on page 5 for changing the temperature set point. The +1.5 C cut-out differential will be maintained regardless of the controller set point.

Defrosting

REF5-BB Series undercounter refrigerators do not require manual defrosting. The unit cooler defrosts automatically when the condensing unit is in the OFF cycle.

Cleaning



Use only non-chlorine-based cleaners. Cleaners containing chlorine can cause staining and pitting of the stainless steel.

Interior – Using a sponge or soft cloth, clean unit with a non-abrasive, non-chlorinated, all-purpose detergent.

Exterior – Wipe exterior with a soft cloth in the direction of grain as needed. Stainless steel polish may be used to enhance the finish of the unit.

Annual cleaning

Removal of dust and other particulates from air intake areas and the condenser is important for proper operation. Some environments with large amounts of dust may require more frequent cleaning.

1. Disconnect power to unit by turning switch on the lower front panel to the OFF position, switching circuit breaker to OFF position, and removing power cord from receptacle.
2. Remove lower front panel (Fig. 16.1).
Note: Front louvered panel may be completely removed for easier cleaning by disconnecting the controller wiring plugs from the freezer.
3. Remove drain pan (Fig. 16.2).
4. Clean drain pan with a non-abrasive, non-chlorinated all-purpose detergent.
5. Reinstall drain pan.
6. Use a vacuum cleaner with brush attachment to clean condenser through lower front panel and compressor motor and related parts through lower rear panel.
7. Reinstall lower front panel.

Fig. 16

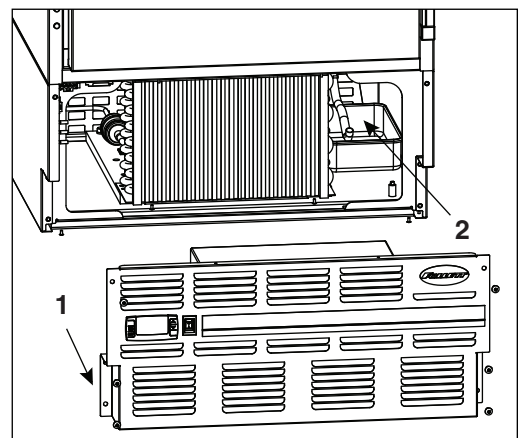

Service

Latch adjustment

To adjust for proper latch engagement

1. Loosen striker plate mounting screws (Fig. 17.1).
2. Move striker plate up or down as required and tighten screws.
3. Test operation of latch.

To adjust for proper gasket seal

1. Loosen striker depth adjustment screw (Fig. 17.2).
2. Adjust stop in or out and tighten screws.
3. Test operation of latch.

Door gasket replacement

1. Remove existing gasket from mounting track.
2. Verify mounting track is free of any remaining gasket material.
3. Align new gasket with mounting track and press firmly in place.
4. Open and close door, checking for proper gasket seal without pinching against refrigerator.
5. Adjust latch and or striker as necessary for proper door closure.

Slide-out compressor tray

Follett's slide-out compressor tray allows technicians to partially slide the condensing unit from the refrigerator back without cutting refrigerant lines.

1. Remove rear panel (Fig. 18.1).
2. Remove two bolts securing condensing unit to refrigerator base (Fig. 18.2).
3. Gently slide condensing unit out (Fig. 18.3).

Note: Do not put undue strain on the refrigerant lines.

Removing drawers

1. Pull drawer forward to stop.
2. Lift drawer front to free front rollers from sides.
3. Still lifted, pull drawer forward to free back rollers from sides.

Removing slides

1. Push slides all the way back.
2. Swing bottom of slide away from refrigerator wall and lift slide off of rollers.

Fig. 17

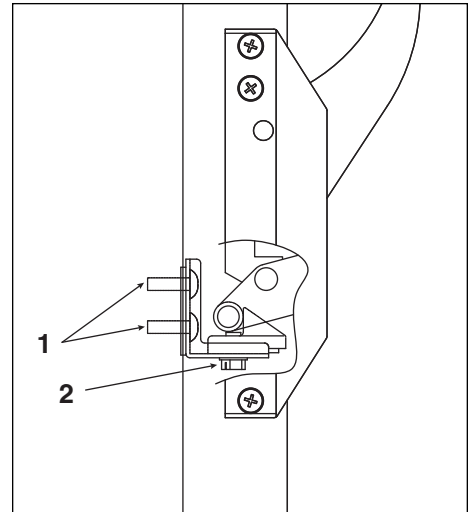
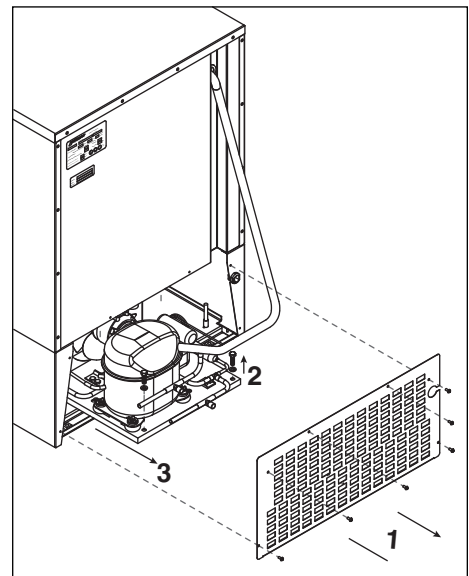

Fig. 18



Controller replacement

1. Disconnect power to unit.
 - a. Push front panel rocker switch to OFF position.
 - b. Disconnect power cord.
2. Remove 6 screws from front panel and slide panel forward to access back of controller.
3. Disconnect front panel and wiring harness from refrigerator at the 3, and 4 pin connectors to simplify replacement.
4. Push in on center of side brackets (on controller) to release and slide brackets back and off controller.
5. Push controller and wires out through front of front panel.
6. Using wiring schematic (attached to front panel and below) as a guide, remove wires one at a time from back of existing controller and connect to corresponding terminals on replacement controller.
7. Insert replacement controller back through front of panel.
8. Slide brackets onto sides of controller and push against back of front panel.
9. Reconnect 3 and 4 pin connectors of wiring harness to refrigerator.
10. Keeping wiring clear of condenser, replace front panel.
11. Restore power and test operation. Reprogram replacement controller if necessary.

Wiring diagram

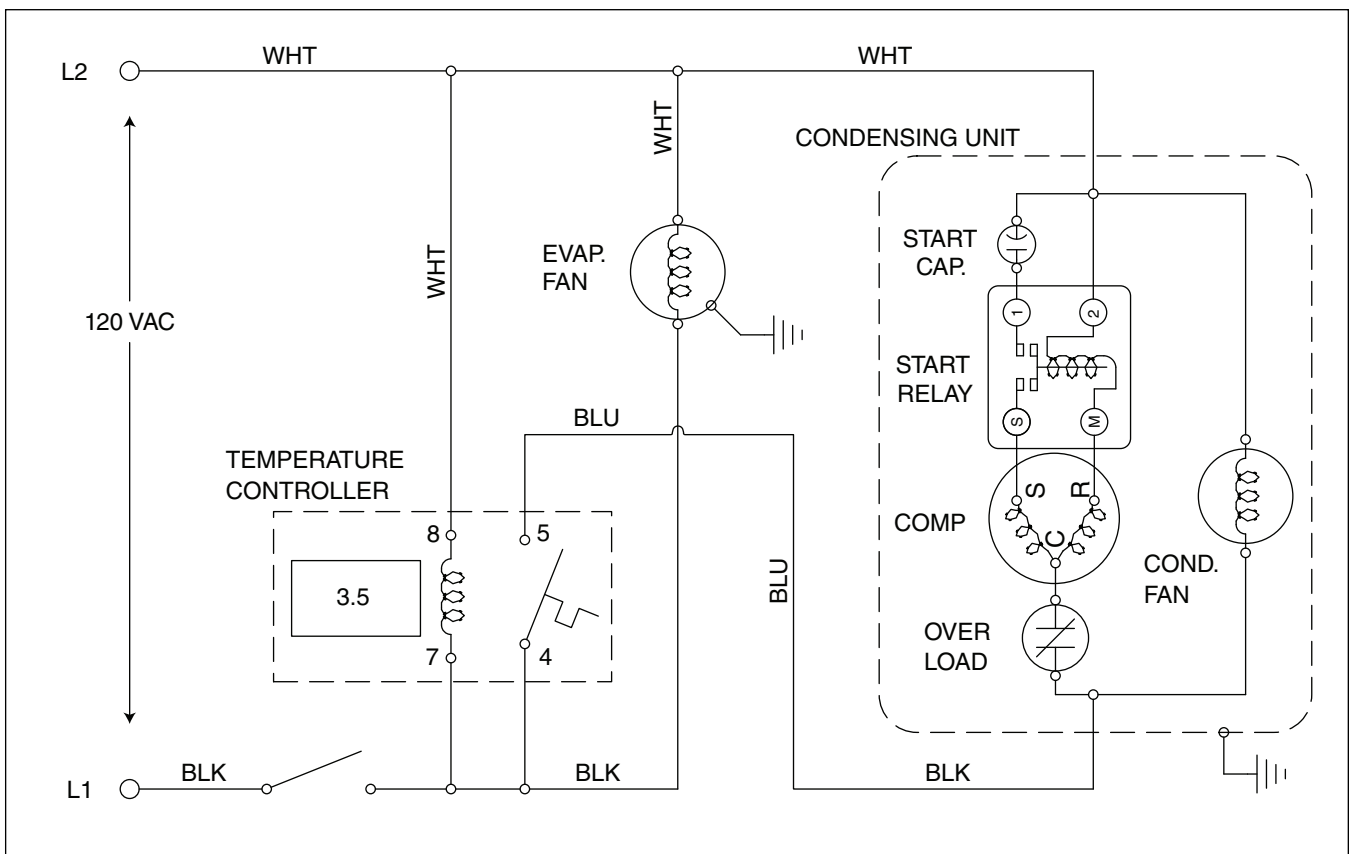

Refrigeration system

The REF5-BB series refrigeration system is designed to give many years of trouble-free service. Except for routine cleaning of the air-cooled condenser and related parts, the refrigeration system requires no service or maintenance. The system uses a thermostatic expansion valve and is critically charged. Access fittings are provided for ease of service. However, the connection of refrigeration service hoses to the fittings will almost invariably result in a significant change in the system charge. This change can adversely affect the performance of your refrigerator. Therefore, Follett recommends that if hoses are ever connected to the refrigeration system for service, the refrigerant should be recovered, the system evacuated, and recharged by weighing in the correct refrigerant charge.

Note: Do not charge the system by pressures.

Checking refrigeration system pressures

1. Remove the rear access panel (Fig. 9).
2. Turn the power switch to the on position.
3. Following the instructions on page 5 verify that the temperature controller is set to the original factory set point (cut-out) setting of +3.5 C (+38 F).
4. Allow the refrigerator to operate and stabilize at least 30 minutes, verifying the cut-out temperature is being reached.
5. Connect refrigerant hoses to access fittings and measure air temperature at condenser intake grille.
6. Verify correct pressures with the temperature chart below.
7. Troubleshoot refrigeration system as needed.

Condenser inlet air temperature	70 – 100 F
Discharge pressure (psi)	190 – 210
Suction pressure (psi)	40 – 50

Note: Do not attempt to obtain correct refrigeration pressures by adjusting the system charge.

Refrigeration system diagram

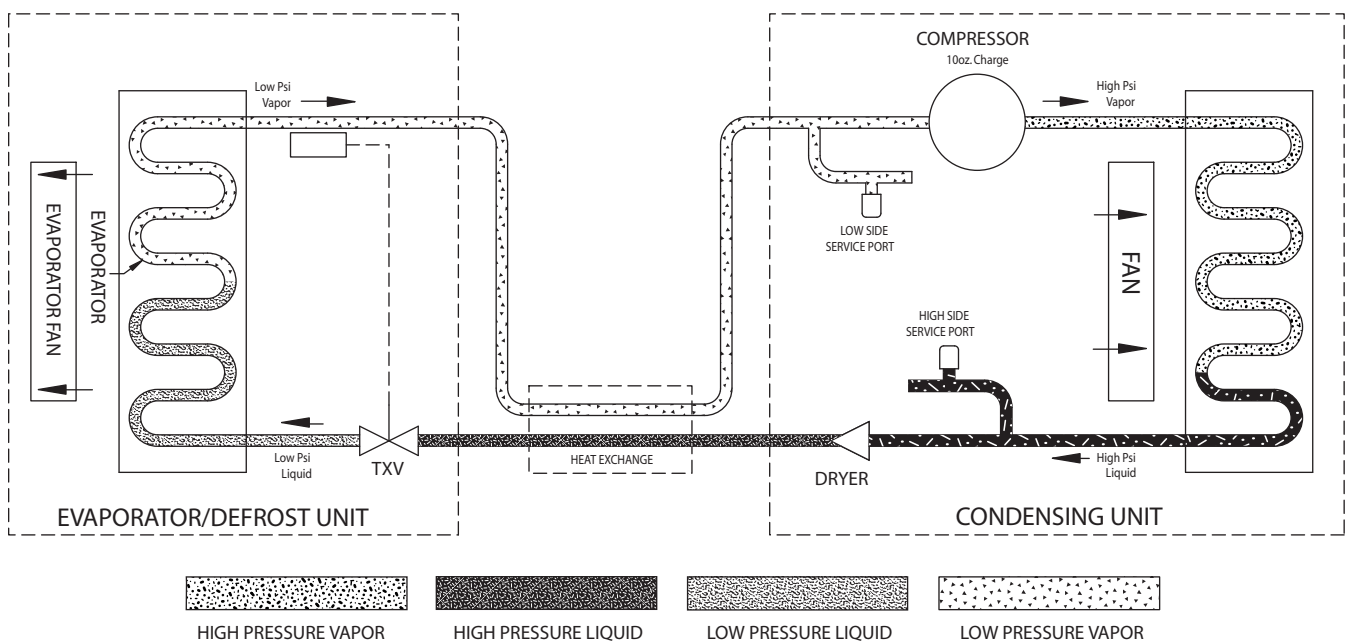

Blood bank refrigerator troubleshooting guide

Before calling for service

1. Check that unit is plugged in.
2. Test outlet with another appliance to verify power.

Symptom	Possible cause	Solution
Refrigerator does not operate (no components run).	<ol style="list-style-type: none"> 1. Power switch faulty or in OFF position; loose connection. 2. Refrigerator not plugged in. 3. No power to cord. 4. Temp controller not energizing components. 5. Probe not sensing cut in temperature. 	<ol style="list-style-type: none"> 1. Turn power switch to ON position; check switch and connections. 2. Connect plug. 3. Restore power. 4. Check controller contact terminals for power. Replace controller if needed. 5. Replace controller and/or probe.
Compressor does not run.	<ol style="list-style-type: none"> 1. Thermal overload open or defective. 2. Capacitor and/or relay defective. 3. Compressor defective. 	<ol style="list-style-type: none"> 1. Allow to cool or replace. 2. Replace as required. 3. Replace compressor.
Evaporator fan motor does not run.	<ol style="list-style-type: none"> 1. Defective fan motor. 	<ol style="list-style-type: none"> 1. Replace fan motor.
Refrigerator does not shut off.	<ol style="list-style-type: none"> 1. Controller not sensing cut off temperature. 2. Controller keeping refrigeration system energized. 	<ol style="list-style-type: none"> 1. Replace controller and/or probe. 2. Replace controller.
Refrigerator does not maintain temperature (all components run).	<ol style="list-style-type: none"> 1. Condenser or evaporator coil needs cleaning. 2. Faulty door gasket or hinges/latch loose 3. Excessively high ambient. 4. Refrigerant leak. 5. Incorrect refrigerant charge. 6. Plugged or defective expansion valve. 7. Inefficient compressor. 	<ol style="list-style-type: none"> 1. Clean coils as needed. 2. Replace door gasket. 3. Maximum recommended ambient is 100 degrees F. 4. Locate and repair leak. 5. Recover, evacuate and weigh in correct charge. 6. Replace expansion valve. 7. Consult technical service.

If problems persist after following this basic troubleshooting guide, call Follett's technical service group at (800) 523-9361 or (610) 252-7301.

Replacement parts

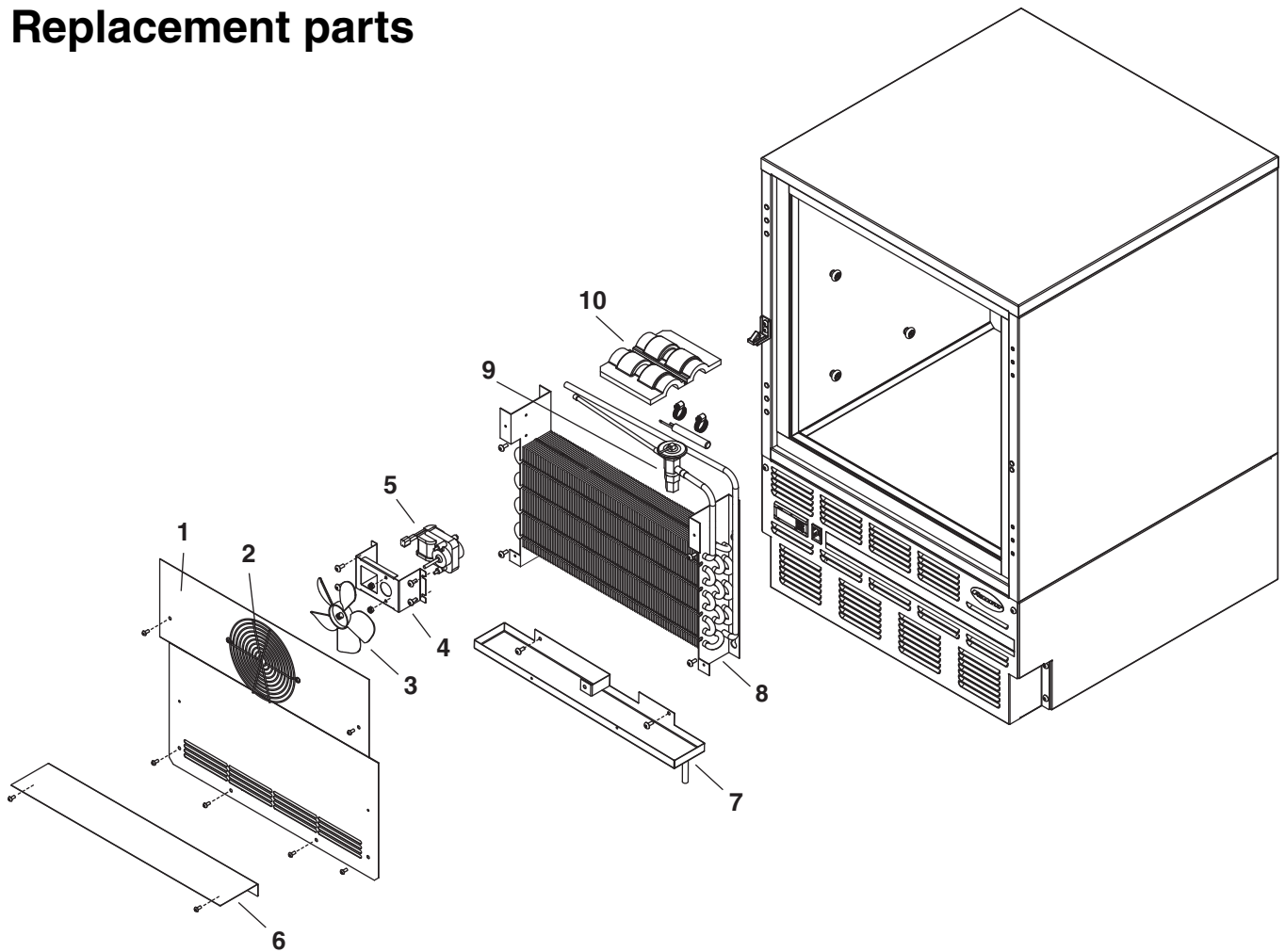

Evaporator

Reference #	Description	Part #
1	Cover, evaporator, (includes 00152892)	00155564
2	Fan guard	00152892
3	Fan blade	00152991
4	Bracket, fan motor	00152983
5	Fan motor, evaporator	00104919
6	Air baffle	00165126
7	Drain pan, evaporator	00162511
8	Evaporator	00151563
9	Expansion valve (includes 00106534)	00165118
10	Insulation, bulb	00106534

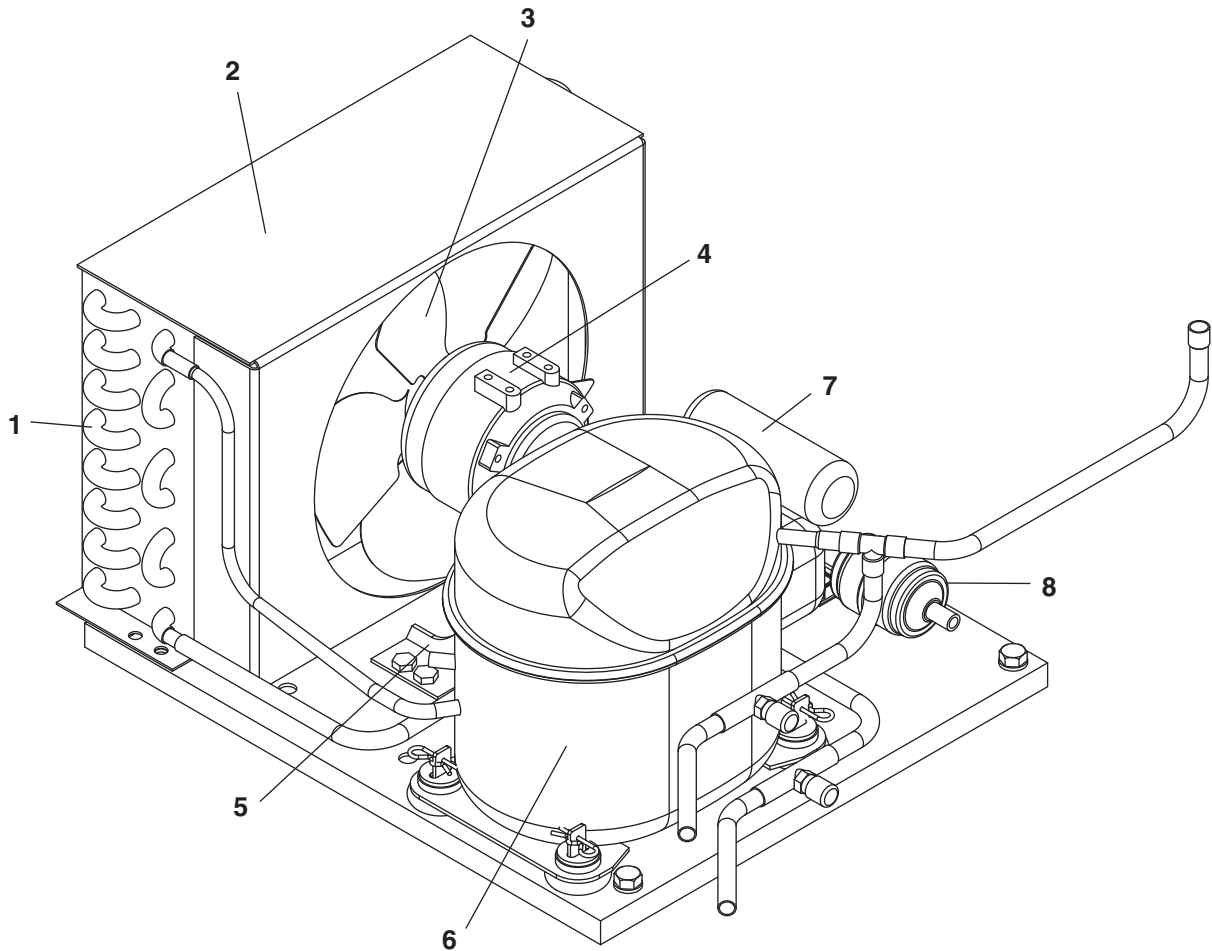

Condensing Unit

Reference #	Description	Part #
	Condensing unit	00105106
1	Condenser	00105619
2	Shroud, condenser	00157347
3	Condenser fan blade	00105007
4	Condenser fan motor	00104992
5	Fan motor bracket	00157412
6	Compressor	00104950
7	Starting capacitor	00104968
8	Filter drier	502724
Not shown	Cap, starting capacitor	00105627
Not shown	Starting relay	00104976
Not shown	Overload protector	00104984

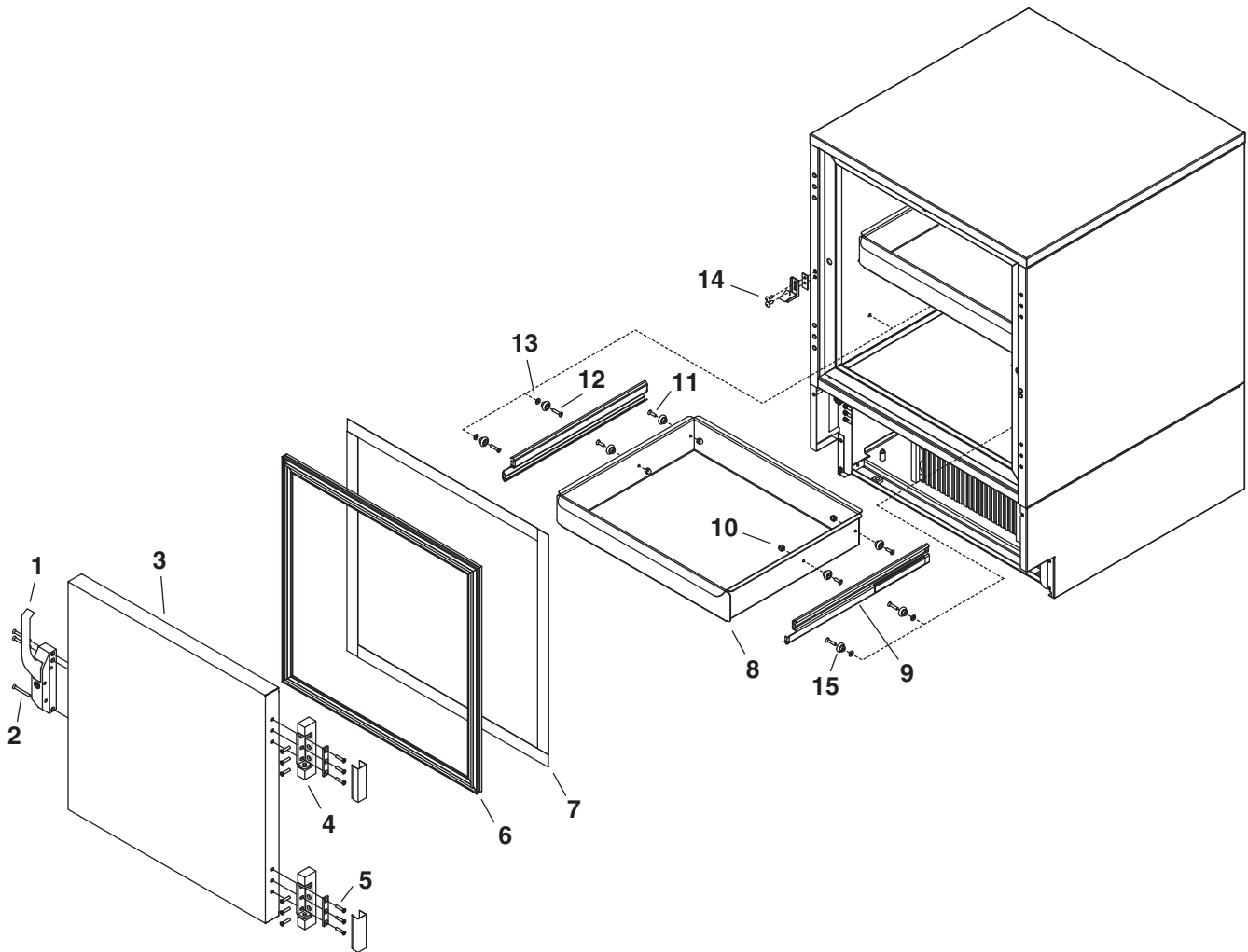

Hardware

Reference #	Description	Part #
1	Latch & striker includes screws	00105023
2	Latch screws, 3 per latch	00103507
3	Door, REF5-BB (includes gasket - 21 3/8" x 21 3/8")	00105015
4	Hinge, each - 2 required, includes screws	00105031
5	Hinge screws, each - 6 per hinge	00105080
6	Gasket, REF5-BB	00125732
7	Strip sealer (set of 4) REF5-BB	00130138
8	Drawer (includes 8 and 4 each of 10, 11 & 15)	00165134
9	Drawer slides (pair)	00161927
10	Nut, acorn, each (4 required per drawer)	00161802
11	Screw, 5/8", each (4 required per drawer)	200093
12	Screw, 7/8", each (4 required per drawer)	00161794
13	Washer, each (4 required per drawer)	00161786
Kit	Drawer & slide mounting hardware kit (includes 8, 9, 4 each of 10, 11, 12, 13 and 8 each of 15)	00165142
14	Striker screws, each - 2 per striker	502287
15	Bearing, roller	00167726
Kit	Slide & bearings (includes 9 (pair) and 4 each of 12, 13 & 15)	00167924
Kit	Bearings & screws kit (includes 8 each of 15 and 4 each of 10, 11, 12 & 13)	00167957

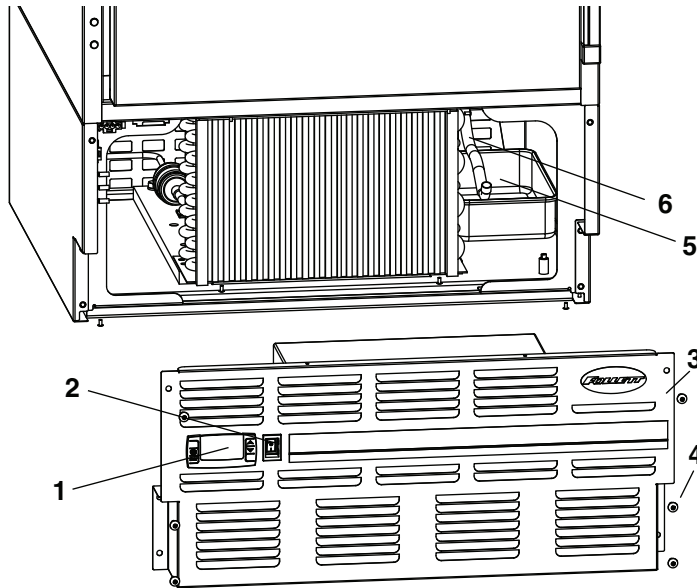

Hardware & electrical components

Reference #	Description	Part #
1	Temperature controller	00900100
Not shown	Temperature probe & harness	00165167
2	Power switch	00114371
3	Front panel (includes 00114371 and 00105379)	00165159
4	Front panel screws, each - 6 per panel	00105379
Not shown	Rear panel, includes screws	00130161
Not shown	Rear panel screws, each - 6 per panel	00105387
5	Condensate pan	00155622
6	Evaporator drain line, sold by the foot	203627
Not shown	REF5-BB programming key, degrees C	00193367
Not shown	Power cord	00103903

Chart recorder related items

Reference #	Description	Part #
Not shown	Gasket, bottle, 125 mL	00171124
Not shown	Bracket, bottle, 125 mL	00171132
Not shown	Bottle, 125 mL	00171116
Not shown	Battery	00112177
Not shown	6" replacement, 7 day charts (quantity of 60)	00162099
Not shown	Replacement pens (quantity of 6)	00162081
Not shown	Probe, chart recorder	00162073

