

FZR Series Undercounter Freezer

Order parts online
www.follettice.com

Installation, Operation and Service Manual

Serial numbers C83253 and above

Serial numbers below C83253 equipped with evaporator defrost heater retrofit kit

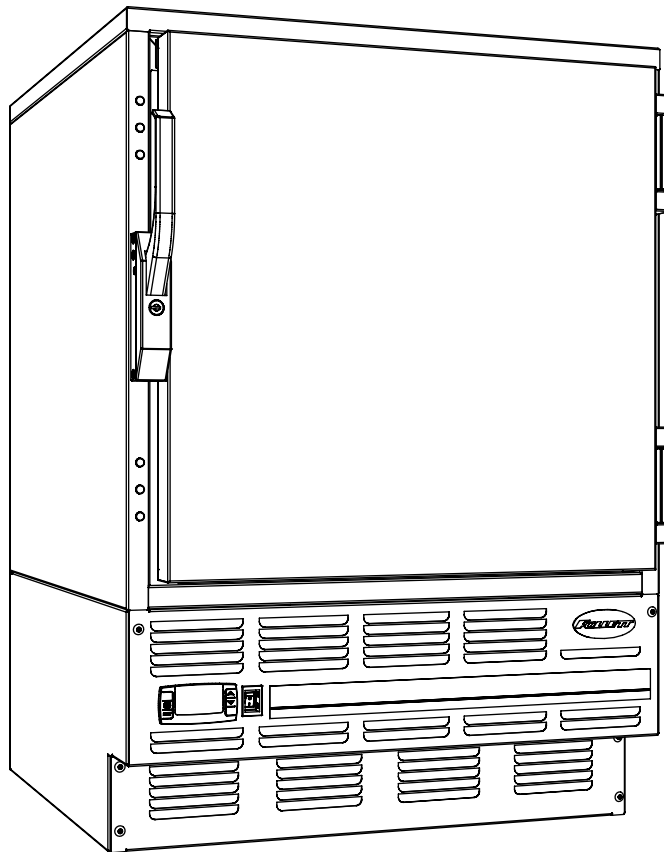

**Following installation, please forward this manual
to the appropriate operations person.**

Contents

Specifications	3
Series specifications	3
Refrigeration specifications	3
Installation specifications	3
Installation	4
Installing legs – required	4
Installation shelves – required	4
Changing temperature controller settings – optional	4
Reversing the door swing – optional	5
Controller operation	6
To display temperature cut-out	6
To change temperature cut-out	6
Controller security	7
To lock the controller	7
To unlock the controller	7
Controller programming key - “hot key”	7
Programming freezer from a controller programming key - “hot key” (download)	7
Operation	8
Temperature control	8
Defrosting	8
Cleaning	9
Interior	9
Exterior	9
Annual Cleaning and Inspection	9

Service	10
Latch adjustment	10
Door gasket replacement	10
Slide-out compressor tray	10
Controller replacement	11
Wiring diagram	11
Refrigeration system	12
Checking refrigeration system pressures	12
Discharge and suction pressure table	12
Refrigeration system diagram	12
Freezer troubleshooting guide	13
Accessory Installation	14
Temperature surveillance module accessory	14
Temperature alarm accessory	14
Pedestal base	14
Stacking kit	14
Replacement parts	15
Evaporator	15
Condensing unit	16
Hardware	17
Hardware & electrical components	18

Follett Corporation Equipment Return Policy

Follett equipment may be returned for credit under the following conditions:

1. The equipment is new and unused.
2. A return authorization number has been issued by customer service within 30 days after shipment.
3. Follett receives the equipment at the factory in Easton, PA within 30 days after issuance of the return authorization number.
4. The equipment must be returned in Follett packaging. If the packaging has been damaged or discarded, Follett will forward, at the customer's expense, new packaging.

Note: Return freight charges are the responsibility of the customer. If equipment is returned and is damaged because of improper packaging, Follett Corporation will not be held responsible.

Credit will be issued when: The equipment has been inspected by Follett and deemed suitable to be returned to stock.

Note: A 15% restocking charge will be deducted from the credit. If the cost to return the product to stock exceeds 15%, the actual cost will be deducted.

Welcome to Follett

Follett equipment enjoys a well-deserved reputation for excellent performance, long-term reliability and outstanding after-the-sale support. To ensure that this product delivers that same degree of service, we ask that you take a moment to review this manual before beginning the installation. Should you have any questions or require technical help at any point, please call our technical service group at (800) 523-9361 or (610) 252-7301.

Before you begin

After uncrating and removing all packing material, inspect the equipment for concealed shipping damage. If damage is found, notify the shipper immediately and contact Follett Corporation so that we can help in the filing of a claim, if necessary.

Check your paperwork to determine which item number you have. Follett item numbers are designed to provide information about the type of freezer you are receiving. Following is an explanation of the different item numbers.

Model Number	Item Number	Stackable/Use with Pedestal*
FZR5	FZR5-000000	
	FZR5-00ST00	X
FZR4-ADA	FZR4-000000	
	FZR4-00ST00	X

Specifications

Series specifications

FZR5	34" (864mm) high	fits below standard 36" (915mm) high counter	4.0 cu ft (1.2 cu m) capacity
FZR4-ADA	31.25" (794mm) high	fits below 34" (864mm) high ADA-compatible counter	3.3 cu ft (1.0 cu m) capacity

Electrical specifications

115V, 60Hz, 1 phase

Full load amps: 8.0

Minimum circuit ampacity: 15 amp

Maximum size of branch circuit overcurrent device: 15 amp

Refrigeration specifications

Refrigerant – R404A

Charge size – 10 oz

Maximum design pressures: High side – 383 psi; Low side – 175 psi

Installation specifications

Ambient temperature must not exceed 86 F (30 C). Relative humidity 60%.

The front louvered panel must be kept free of any cabinet trim or obstructions to ensure proper ventilation of the refrigeration system.

CAUTION

- Equipment must be wired according to local NEC codes.
- Unplug equipment before servicing.
- Be sure to find adequate storage for products prior to unplugging equipment.

Installation

Installing legs – required

1. Remove legs from plastic bag packed inside freezer.
2. Tip freezer back and screw legs in all the way to stop (they will extend 1/8" (3.175mm) below base of freezer).
3. Adjust legs as needed to level freezer in both directions. To access legs, remove the lower front panel. Turn legs clockwise to extend legs.

Fig. 1

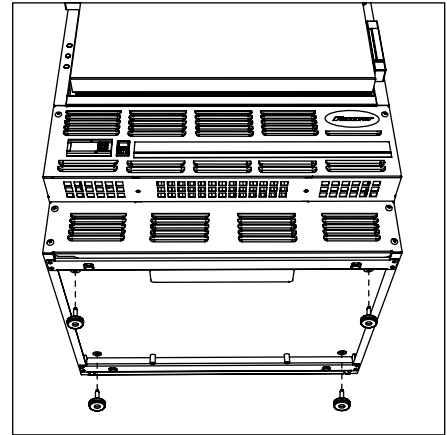

Installation shelves – required

1. Remove shelves and shelf brackets packed inside freezer.
2. Install shelf brackets in pilasters (insert top tab, squeeze and push in lower tab).

Fig. 2

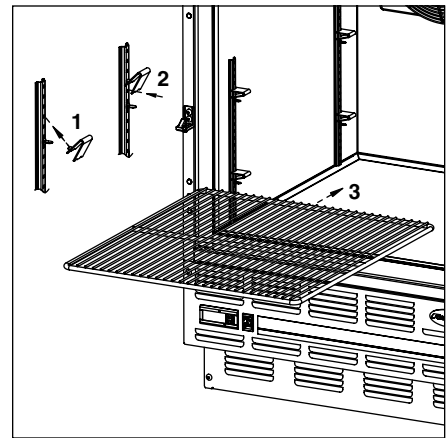

Changing temperature controller settings – optional

Follett's temperature controller is pre-programmed with a -25 C (-13 F) set point and degrees C display. The -25 C (-13 F) set point delivers a temperature range of -23 to -25 C (-9 to -13 F).

Follett's controller set point can be changed to deliver up to a -15 C (+5 F) temperature for applications where a lower temperature is not desired (i.e. ice cream). See page 6 to change controller settings.

Fig. 3

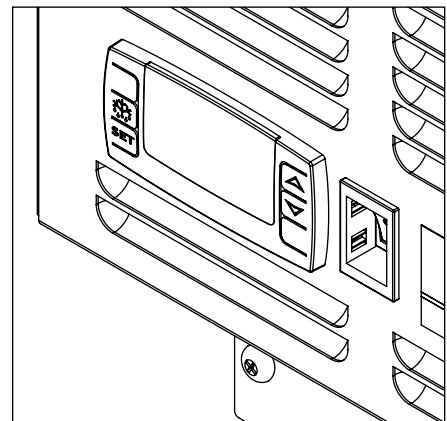

Reversing the door swing – optional

NOTICE

When reinstalling latch and hinge screws, 242 blue Loctite* MUST be applied to screws. Torque screws to 25 in-lbs.

1. Remove screws and latch from refrigerator cabinet (Fig. 4.1).
2. Use flat screwdriver to carefully remove (do not scratch) hinge covers (Fig. 5.1).
3. Support door and remove screws attaching hinge to refrigerator cabinet (Fig. 5.2).
4. Cover hinge screw holes with screw hole plugs removed from opposite side.
5. Reverse door. Apply 242 blue Loctite to hinge screws and reinstall torqued to 25 in-lbs.
6. Reinstall latch on opposite side.
7. Remove screws and handle from door (Fig. 6.1).
8. Rotate handle (Fig. 6.2).
9. Apply 242 blue Loctite to latch screws and reinstall torqued to 25 in-lbs.

Fig. 4

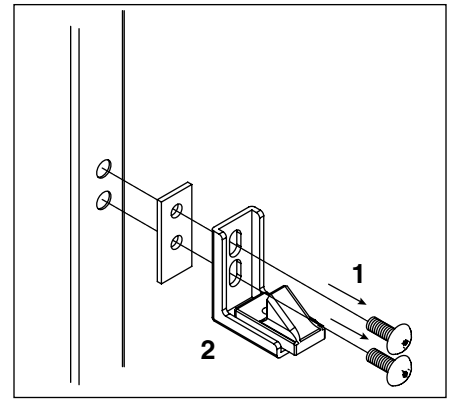

Fig. 5

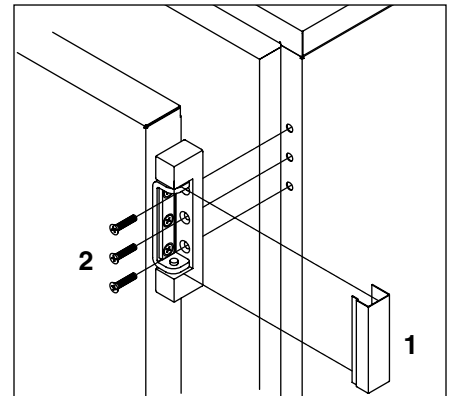
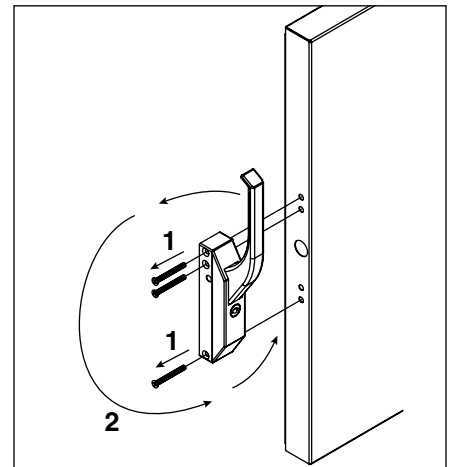

Fig. 6



* Loctite is a registered trademark of Henkel Corporation in the United States and other countries.

Controller operation

In normal operation the controller displays cabinet temperatures in degrees C (default). Degrees F can be uploaded from controller programming key - “hot key” (see page 7). Degrees C temperatures are displayed to 1 decimal point.

Up/down/set membrane switches at right and left of the temperature display control all programming functions.

The controller is pre-programmed with a -25 C (-13 F) set point which provides a compressor cut-in at -23 C (-9 F) and cut-out at -25 C (-13 F). The controller set point can be raised to -15 C (+5 F) for nourishment applications where a lower temperature is not desired (i.e. ice cream). Follow instructions for changing temperature cut-out below.

All set points have a 2 C differential. The 2 C differential means that with a -25 C set point, for example, the compressor will turn off at -25 C (-13 F) and turn on when it reaches -23 C (-9 F).

Fig. 7

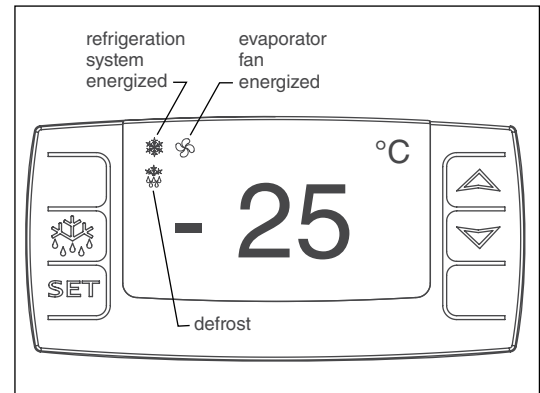

To display temperature cut-out

STEP	INPUT	DISPLAY
1	Press and release SET	Current cut-out temperature will display for approximately 5 seconds. Display will return to current refrigerator temperature.

To change temperature cut-out

STEP	INPUT	DISPLAY
1	Press and hold SET for 3 seconds	Current cut-out temperature displayed and °C (°F) will flash
2	Press UP or DOWN arrows to desired cut-out temperature	New cut-out temperature displayed
3	Press and release SET	New cut-out temperature blinks three times, then current refrigerator temperature will display

Controller security

The controller panel can be locked to prevent inadvertent or intentional programming changes. In locked mode, the controller will display cabinet temperature and cut-out set point only.

To lock the controller

1. Press the UP and DOWN ARROW buttons together for 3 seconds until “PoF” displays (will flash 3 times).
2. Programmer is now locked.

To unlock the controller

1. Press UP and DOWN ARROW buttons together for 3 seconds until “Pon” displays (will flash 3 times).
2. Programmer is now unlocked.

Controller programming key - “hot key”

A controller programming key is available from Follett to provide fast and easy reprogramming of factory settings.

Program Serial# Range	Frequency of Defrost	Maximum Duration of Defrost	Temp Display °	FZR4-ADA & FZR5 – Item#
Below # C45184	4 hrs	15 min	C	00923938
	4 hrs	15 min	F	00923946
Below # C83253	4 hrs	15 min	C	00923656
	4 hrs	15 min	F	00923664
Above # C83253	6 hrs	15 min	C	00923672
	6 hrs	15 min	F	00923680

Programming freezer from a controller programming key - “hot key” (download)

1. TURN OFF freezer.
2. Remove 6 screws from panel holding controller to access back of controller.
3. Insert programmed key into 5 PIN receptacle on controller back.
4. TURN ON freezer.
5. Values from key automatically download to freezer (“dol” message blinks followed by “end”).
6. After 10 seconds display returns to current freezer temperature and controller will restart with new values.
7. TURN OFF FREEZER.
8. Remove key.
9. Reinstall panel.

Note: An “Err” message displays for failed programming. Turn freezer OFF then ON to restart download, or remove key to abort.

Operation

The temperature controller and probe indicate when the refrigeration system is required to turn on and off.

The refrigeration system removes heat from the cabinet interior and rejects it to the surrounding room air. When the cabinet interior temperature reaches +2 C (+4 F) above the controller set point, the probe signals the controller to turn the refrigeration system on. The normally-open controller contacts 4 and 5 close and energize the evaporator and condenser fan motors, compressor and door heater. The snowflake and fan LED's on the controller will come on to indicate the refrigeration system is on. The compressor uses a current-style starting relay and a starting capacitor to start the compressor motor.

When the cabinet interior temperature falls to the set point, the probe signals the controller to turn the refrigeration system off. The controller contact 5 reopens, which de-energizes the condenser fan motor and the compressor. The snowflake LED will go out and the fan LED will remain on.

Any accumulated frost on the evaporator coils melts during the defrost cycle. The condensate drains to a drain pan mounted along the condensing unit. The heat from the condensing unit evaporates any condensate in the drain pan.

Temperature control

The temperature control system is preset by the factory to maintain a cabinet temperature of -23 C (-10 F). If desired, the cut-out temperature can be raised as high as -15 C (5 F) by following the instructions on page 6 for changing the temperature set point. The 2 C cut-out differential will be maintained regardless of the controller set point.

Defrosting

The FZR series undercounter freezers control frost accumulation on the evaporator through automatic timed defrost cycles. The defrost cycle is initiated by the temperature controller every 6 hours. Contacts 4 and 5 on the controller open and the refrigeration system is turned off. Contact 2 is closed and the defrost heater is energized. The melting snowflake LED on the controller will come on, and the temperature display will read "dEF" to indicate the freezer is in the defrost cycle.

The heaters warm the evaporator coil and drain pan to melt the frost and drain the water to the condensate pan. The temperature controller monitors evaporator temperature using a probe embedded in the coil. The controller terminates the defrost cycle when the evaporator temperature reaches +5 C (+41 F) or after 15 minutes of defrost time, whichever occurs first. As the defrost cycle terminates, the controller de-energizes the heater and restarts the compressor and condenser fan. The snowflake LED on the controller will come on to indicate the refrigeration system is running.

There is a 5 minute delay before the evaporator fan motor is re-energized. The fan LED on the controller will come on to indicate the fan is running and the temperature display resumes displaying cabinet temperature. A defrost cycle can be initiated manually at any time by depressing and holding the melting snowflake button for approximately three seconds. As a safety feature, a temperature safety switch mounted on the evaporator will turn off the defrost heater if the temperature of the evaporator reaches +27 C (+80 F) regardless of controller operation.

The FZR series freezers have been designed specifically for the storage of temperature-critical medications. Other storage applications may require modifications of the factory-programmed defrost cycle settings. Please consult Follett technical service if defrost modification is needed.

Note: Storage of products with very low volumes may require additional product insulation.

Note: Serial numbers below C57095 were programmed with defrost cycles every 2-4 hours terminating at +5 C (+41 F) or after 15 minutes, whichever came first. If you are experiencing problems with frost on any of these earlier units, please call Follett's technical service department at (800) 523-9361 or (610) 252-7301 for a programming key to update your unit to the most current program settings.

Cleaning

⚠ CAUTION

- Use only non-chlorine based cleaners. Cleaners containing chlorine can cause staining and pitting of the stainless steel.

Interior

Using a sponge or soft cloth, clean unit with a non-abrasive, non-chlorinated, all-purpose detergent.

Exterior

Wipe exterior with a soft cloth in the direction of grain as needed. Stainless steel polish may be used to enhance the finish of the unit.

Annual Cleaning and Inspection

1. Shut down unit by turning rocker switch on the lower front panel to the OFF position and removing power cord from receptacle.
2. Remove lower front panel (Fig. 8.1).

Note: Front louvered panel may be completely removed for easier cleaning by disconnecting the controller wiring plugs from the freezer.

3. Remove drain pan (Fig. 8.2).
4. Clean drain pan with a non-abrasive, non-chlorinated all-purpose detergent.
5. Reinstall drain pan.
6. Use a vacuum cleaner with brush attachment to clean condenser through lower front panel and compressor motor and related parts through lower rear panel.
7. Reinstall lower front panel.
8. Remove interior shelves.
9. Remove evaporator cover (six screws).
10. Using hair drier, melt all ice from evaporator coil and drain pan.
11. Using a piece of wire, confirm that drain tube is free of ice and clear of any blockage.
12. Check evaporator fan for smooth operation.
13. Reinstall evaporator cover.
14. Reinstall shelves.

Fig. 8

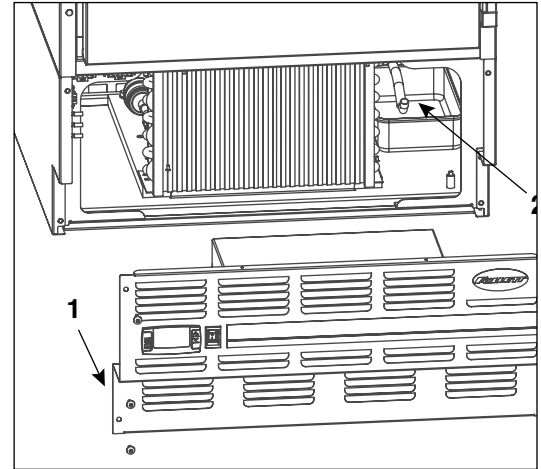

Service

Latch adjustment

To adjust for proper latch engagement

1. Loosen striker plate mounting screws (Fig. 9.1).
2. Move striker plate up or down as required and tighten screws.
3. Test operation of latch.

To adjust for proper gasket seal

1. Loosen striker depth adjustment screw (Fig. 9.2).
2. Adjust stop in or out and tighten screws.
3. Test operation of latch.

Door gasket replacement

1. Remove existing gasket from mounting track.
2. Verify mounting track is free of any remaining gasket material.
3. Align new gasket with mounting track and press firmly in place.
4. Open and close door, checking for proper gasket seal without pinching against freezer.
5. Adjust latch and or striker as necessary for proper door closure.

Slide-out compressor tray

Follett's slide-out compressor tray allows technicians to partially slide the condensing unit from the freezer back without cutting refrigerant lines.

1. Remove rear panel (Fig. 10.1).
2. Remove two bolts securing condensing unit to freezer base (Fig. 10.2).
3. Gently slide condensing unit out (Fig. 10.3).

Note: Do not put undue strain on the refrigerant lines.

Fig. 9

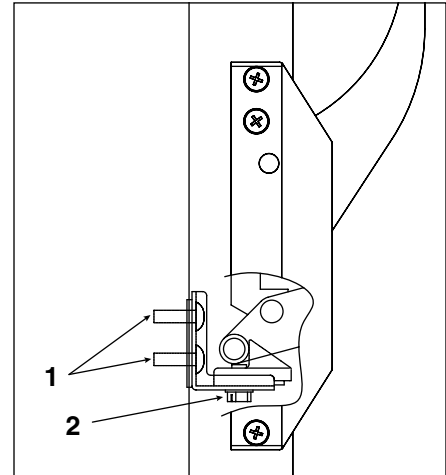
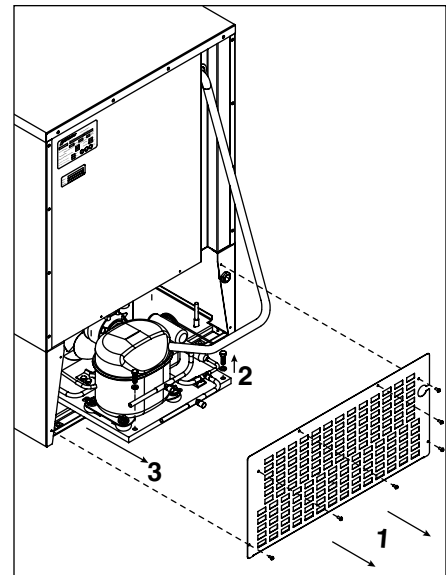

Fig. 10



Controller replacement

1. Disconnect power to unit.
 - a. Push front panel rocker switch to OFF position.
 - b. Disconnect power cord.
2. Remove 6 screws from front panel and slide panel forward to access back of controller.
3. Disconnect front panel and wiring harness from freezer at the 3, 4, and 5 pin connectors and door heater connector to simplify replacement.
4. Push in on center of side brackets (on controller) to release and slide brackets back and off controller.
5. Push controller and wires out through front of front panel.
6. Using wiring schematic (attached to front panel and below) as a guide, remove wires one at a time from back of existing controller and connect to corresponding terminals on replacement controller.
7. Insert replacement controller back through front of panel.
8. Slide brackets onto sides of controller and push against back of front panel.
9. Reconnect 3, 4, and 5 pin connectors of wiring harness to freezer.
10. Keeping wiring clear of condenser, replace front panel.
11. Restore power and test operation. Reprogram replacement controller if necessary.

Wiring diagram

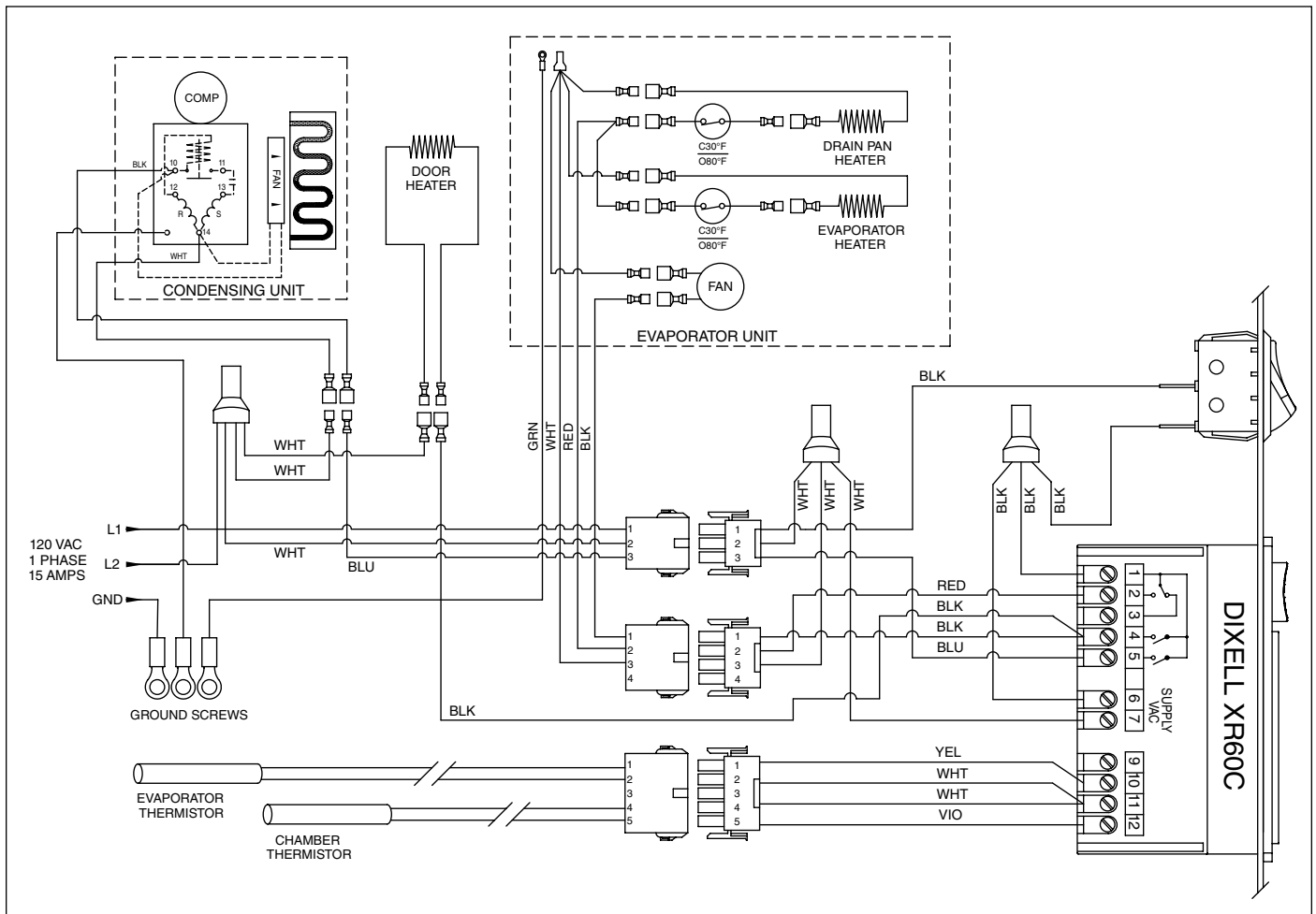

Refrigeration system

The FZR series -20 C (-4 F) freezer refrigeration system is designed to give many years of trouble-free service. Except for routine cleaning and inspection of the air-cooled condenser and evaporator defrost, the refrigeration system requires no service or maintenance. The system uses a thermostatic expansion valve and is critically charged. Access fittings are provided for ease of service. However, the connection of refrigeration service hoses to the fittings will almost invariably result in a significant change in the system charge. This change can adversely affect the performance of your freezer. Therefore, Follett recommends that if hoses are ever connected to the refrigeration system for service, the refrigerant should be recovered, the system evacuated, and recharged by weighing in the correct refrigerant charge.

Note: Do not charge the system by pressures.

Checking refrigeration system pressures

1. Remove the rear access panel (Fig. 11).
2. Turn the power switch to the on position.
3. Following the instructions on page 6 verify that the temperature controller is set to the original factory cut-in setting of -25 C (-13 F).
4. Allow the freezer to operate and stabilize at least 60 minutes, verifying the cut-out temperature is being reached.
5. Connect refrigerant gauges to access fittings and measure air temperature at condenser intake grille.
6. Verify correct pressures with the temperature chart below.
7. Troubleshoot refrigeration system as needed.

Fig. 11

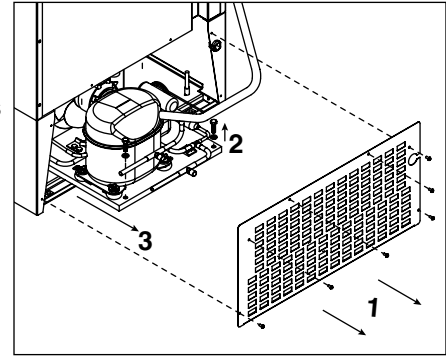

Discharge and suction pressure table

Condenser Inlet Air Temperature	70 F (21 C)	80 F (27C)	90 F (32 C)	100 F (38 C)
Discharge pressure (psi)	197	225	255	285
Suction pressure (psi)	12	13	14	15

Note: Do not attempt to obtain correct refrigeration pressures by adjusting the system charge.

Refrigeration system diagram

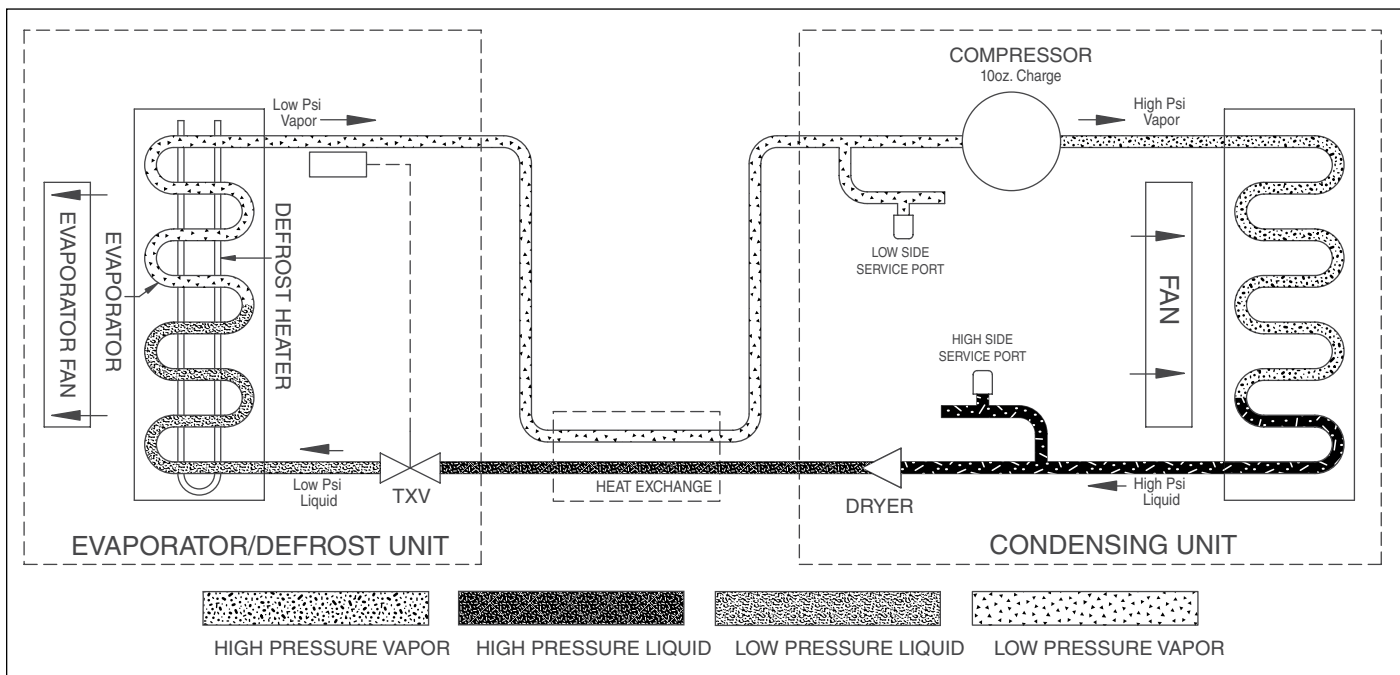

Freezer troubleshooting guide

Before Calling For Service

Check to be sure unit is plugged in. Test outlet with another appliance to verify power

Symptom	Possible Cause	Solution
Freezer does not operate (no components run)	1. Power switch faulty or in OFF position; loose connection.	1. Turn power switch to ON position; check switch connections.
	2. Freezer not plugged in.	2. Connect plug.
	3. No power to cord.	3. Restore power.
	4. Temp controller not energizing components.	4. Check controller contact terminals for power. Replace controller if needed.
	5. Probe not sensing cut in temperature.	5. Replace controller and/or probe.
Compressor does not run	1. Thermal overload open or defective.	1. Allow to cool or replace.
	2. Capacitor and/or relay defective.	2. Replace as required.
	3. Compressor defective.	3. Replace compressor.
Compressor and condenser fan do not run.	1. No power on terminal 5 of controller (during cooling).	1. Replace controller.
Evaporator fan motor does not run.	1. No power on terminal 4 of controller (during cooling).	1. Replace controller.
Freezer does not shut off.	1. Controller not sensing cut off temperature.	1. Replace controller and/or probe.
	2. Controller keeping refrigeration system energized.	2. Replace controller.
Freezer does not maintain temperature (all components run).	1. Fan upgrade needed	1. If fan is not black in color contact Follett for a retrofit kit.
	2. Condenser or evaporator coil needs cleaning.	2. Clean coils as needed.
	3. Faulty door gasket.	3. Replace door gasket.
	4. Excessively high ambient/humidity.	4. Maximum recommended ambient is 86 F (30 C).
	5. Refrigerant leak.	5. Locate and repair leak.
	6. Incorrect refrigerant charge.	6. Recover, evacuate and weigh in correct charge.
	7. Plugged expansion valve.	7. Replace expansion valve.
	8. Inefficient compressor.	8. Consult technical service.
	9. Evaporator coil blocked with ice.	9. Depress defrost button on controller to defrost coil.
Evaporator does not defrost.	1. Defective defrost heater.	1. Replace defrost heater.
	2. Faulty heater safety switch.	2. Replace switch.
	3. No power on terminal 2 of controller (during defrost).	3. Replace controller.
	4. Defrost settings may require change for specific applications.	4. Call Follett's technical service department.
If problems persist after following this basic troubleshooting guide, call Follett's technical service group at (800) 523-9361 or (610) 252-7301		

Accessory Installation

Temperature surveillance module accessory

- Reference instruction# 00168609 (packed with module)

Temperature alarm accessory

- Reference instruction# 00112052 (packed with alarm)

Pedestal base

- Reference instruction# 00192534 (packed with base)

Stacking kit

- Reference instruction# 00192526 (packed with stacking kit)

These instruction sheets are also available in the download section of the Follett website (www.follettice.com).

Replacement parts

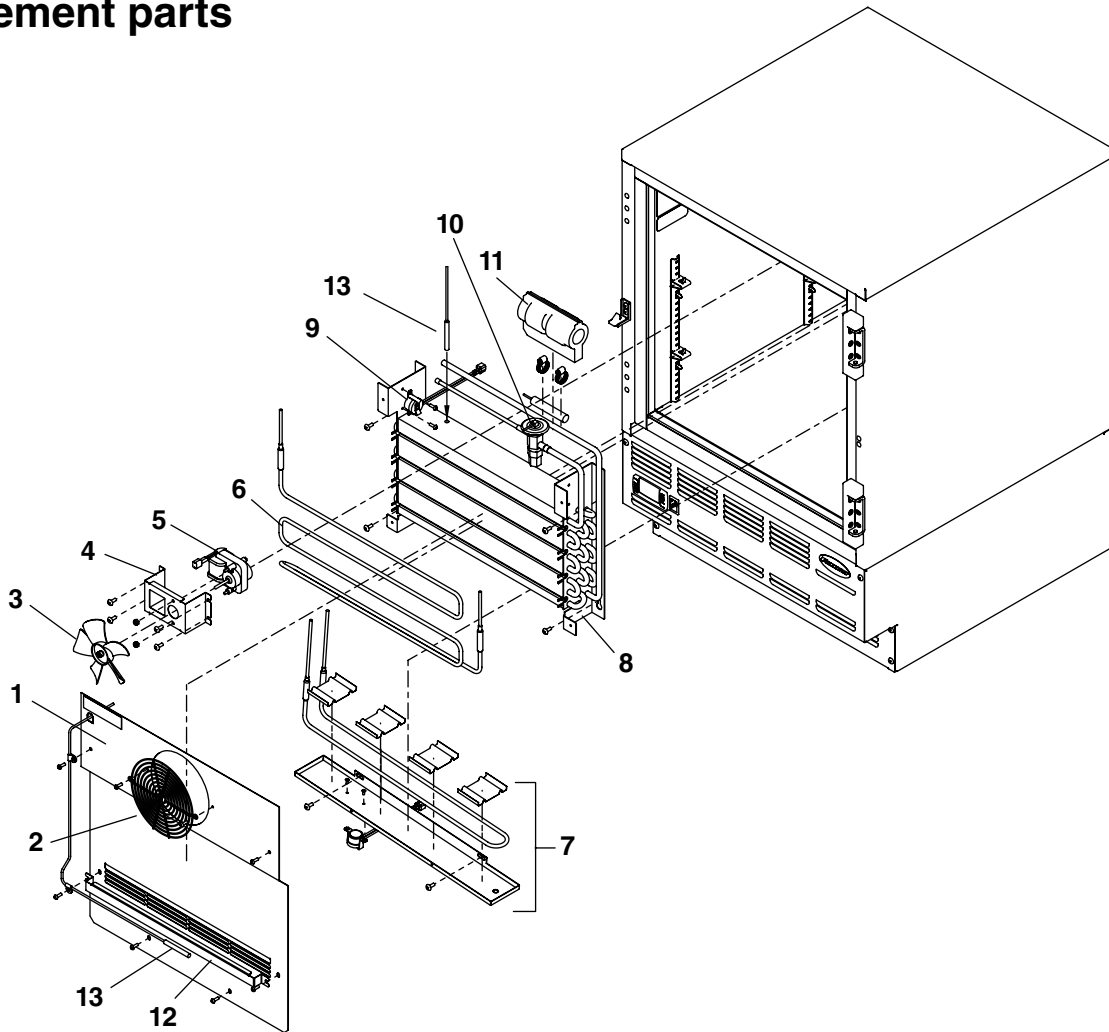

Evaporator

Reference	Description	Part #
1	Cover, evaporator, FZR5 (includes 00152892)	00155564
1	Cover, evaporator, FZR4-ADA (includes 00152892)	00155572
2	Fan guard	00152892
3	Fan blade	00152991
4	Bracket, fan motor	00152983
5	Fan motor, evaporator	00104919
6	Evaporator, defrost heater (above Serial # xxxx)	00923631
6	Evaporator, defrost heater (below Serial # xxxx equipped with retrofit kit)	00923623
7	Drain pan, defrost heater assembly	00923649
8	Evaporator	00151563
9	Heater safety switch	00153932
10	Expansion valve (includes 00106534)	00155671
11	Insulation, bulb	00106534
12	Evaporator cover guard	00157586
13	Probe1 and Probe 2 harness assy	00155705

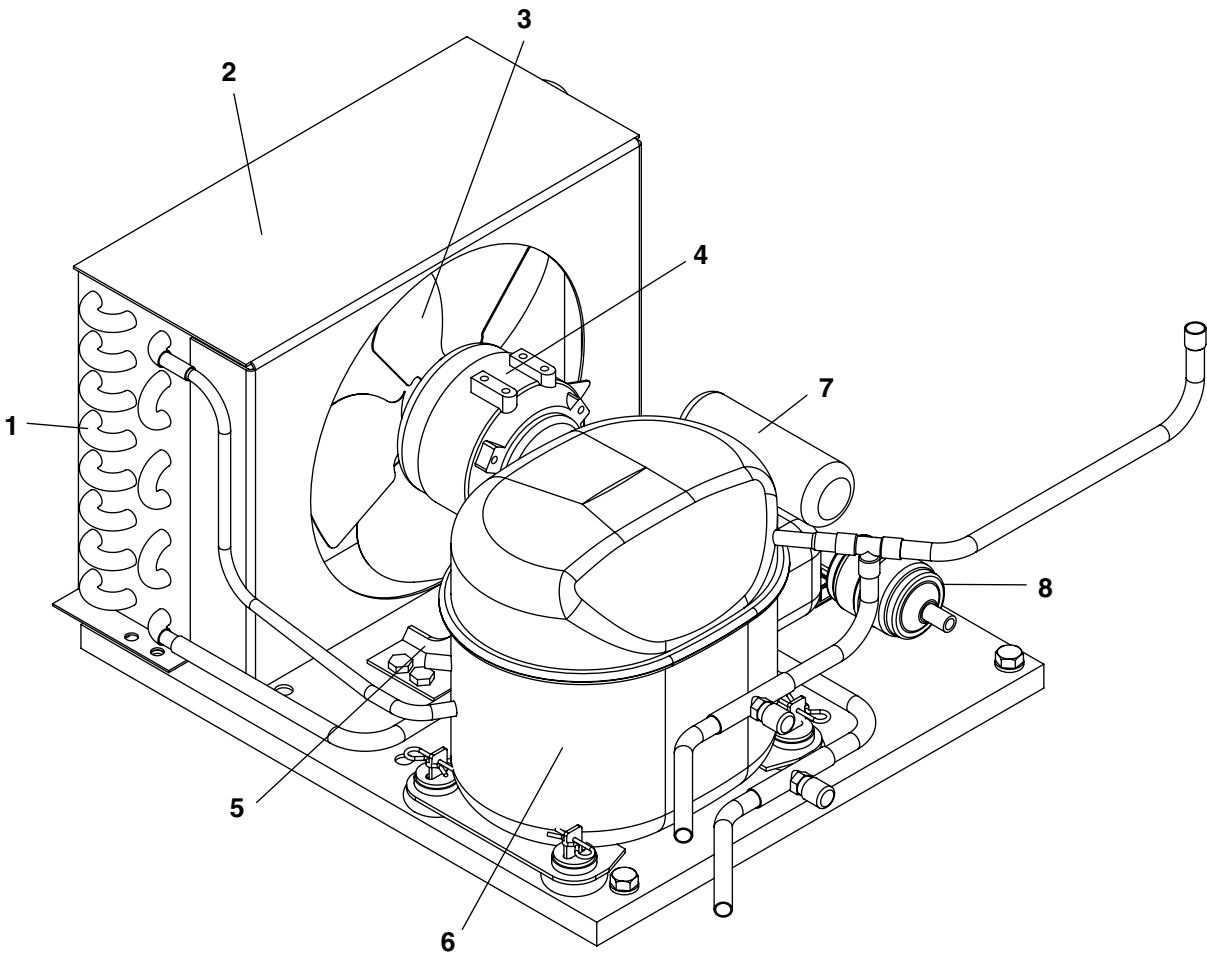

Condensing unit

Reference	Description	Part #
	Condensing unit	00153874
1	Condenser	00157339
2	Shroud, condenser	00157347
3	Condenser fan blade	00105007
4	Condenser fan motor	00104992
5	Fan motor bracket	00157412
6	Compressor	00157313
7	Starting capacitor	00104968
8	Filter drier	502724
Not shown	Cap, starting capacitor	00105627
Not shown	Starting relay	00157305
Not shown	Overload protector	00104984

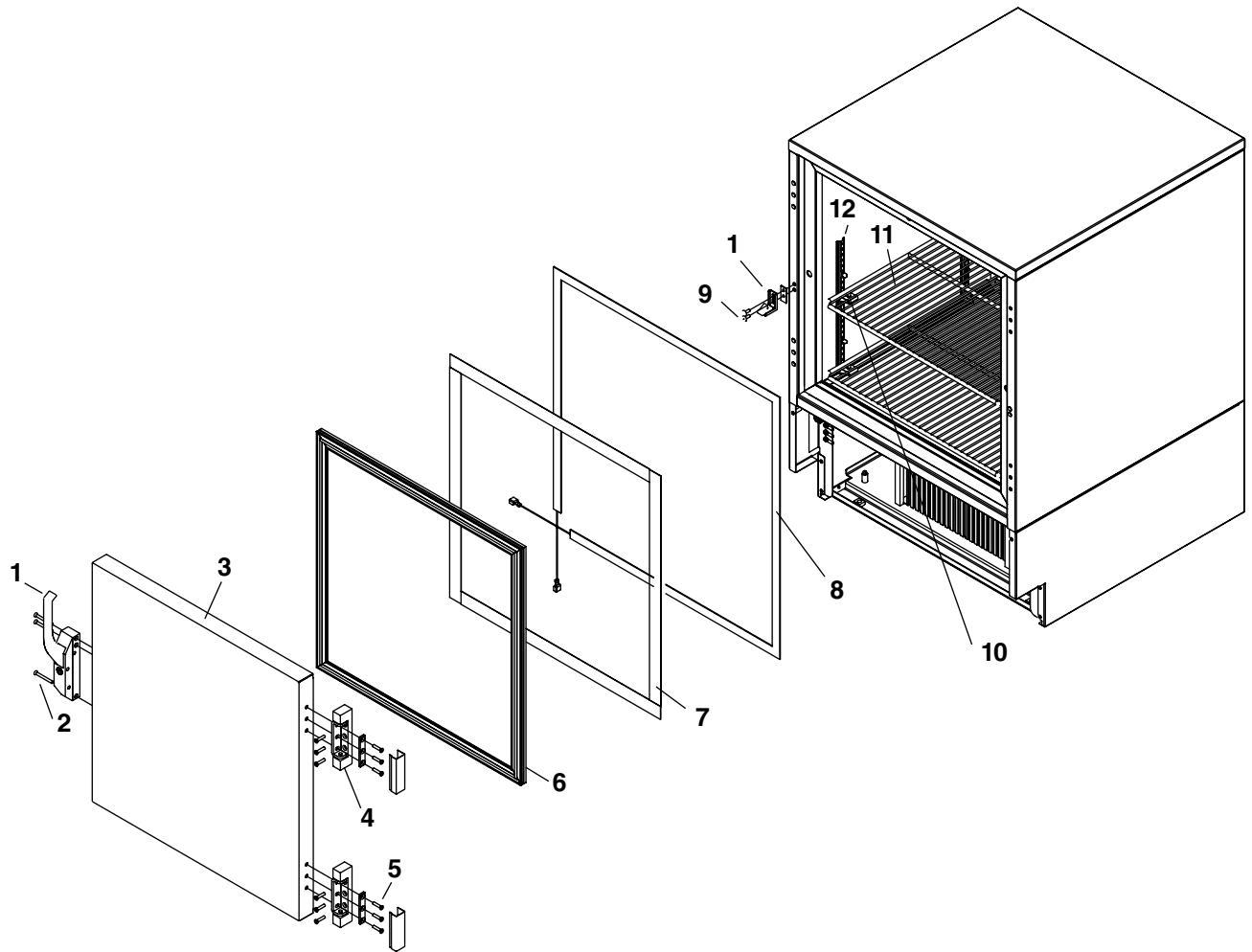

Hardware

Reference	Description	Part #
1	Latch & striker includes screws	00105023
2	Latch screws, 3 per latch	00103507
3	Door, FZR5 (includes gasket - 21 3/8" x 21 3/8")	00105015
3	Door, FZR4-ADA (includes gasket - 21 3/8" x 18 5/8")	00113910
4	Hinge, each - 2 required, includes screws	00105031
5	Hinge screws, each - 6 per hinge	00105080
6	Gasket, FZR5	00125732
6	Gasket, FZR4-ADA	00127738
7	Strip sealer (set of 4) FZR5	00130138
7	Strip sealer (set of 4) FZR4-ADA	00130146
8	Door heater, FZR4-ADA (includes 00130146)	00155549
8	Door heater, FZR5 (includes 00130138)	00155531
9	Striker screws, each - 2 per striker	502287
10	Shelf	00152876
11	Shelf support, snap in, each	00156240
12	Pilaster, each	00105346
Not shown	Thumbscrews, set of 8	00105353

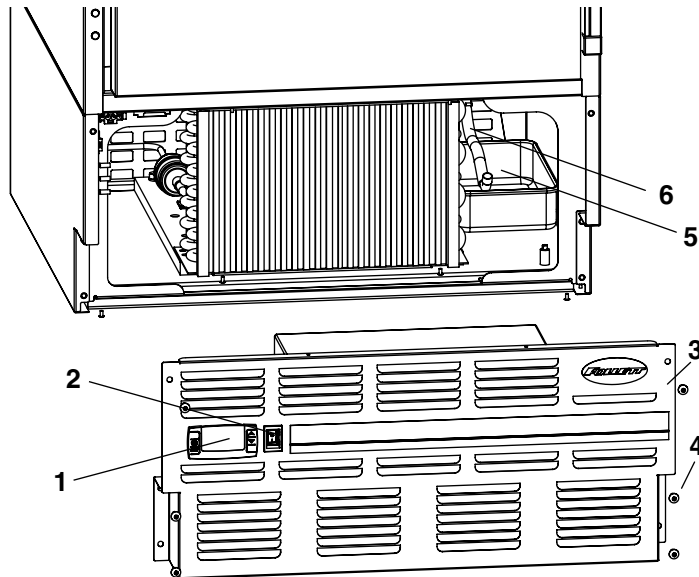

Hardware & electrical components

Reference	Description	Part #
1	Temperature controller	00900092
Not shown	Temperature probes & harness	00155705
2	Power switch	00114371
3	Front panel (includes 00114371 and 00105379)	00157669
4	Front panel screws, each - 6 per panel	00105379
Not shown	Rear panel, includes screws	00130161
Not shown	Rear panel screws, each - 6 per panel	00105387
5	Condensate pan	00155622
6	Evaporator drain line, sold by the foot	203627
Not shown	Freezer programming key, degrees F, 6/15	00193375
Not shown	Freezer programming key, degrees C, 6/15	00923680
Not shown	Power cord	00103903

Temperature alarm accessory

Reference	Description	Part #
Not shown	Bottle kit (includes bottle, bracket and gasket)	00113779
Not shown	Controller kit (includes battery, probe and power supply)	00108175
Not shown	Gasket, bottle	00112029
Not shown	Bracket, bottle	00112011
Not shown	Bottle	00112037
Not shown	Battery	00112177
Not shown	Screws, (includes two for securing cover)	00115063
Not shown	Label, controller cover	00115071
Not shown	Temperature probe	00115097

Follett reserves the right to change specifications at any time without obligation. Certifications may vary depending on country of origin.



801 Church Lane • Easton, PA 18040, USA
Toll free (800) 523-9361 • (610) 252-7301
Fax (610) 250-0696 • www.follettice.com



00939124R00
09/09