

T400A/W, MCD400A/W, R400A/W, MFD400A/W, D400A/W Icemakers

Order parts online
www.follettice.com

Installation, Operation and Service Manual

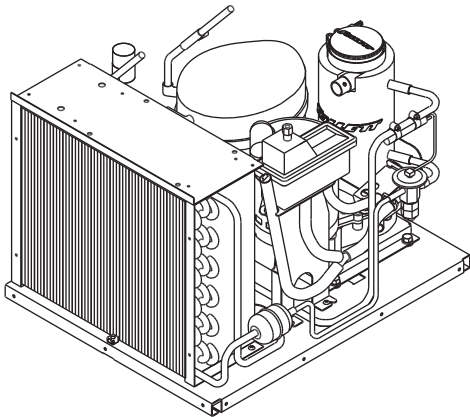
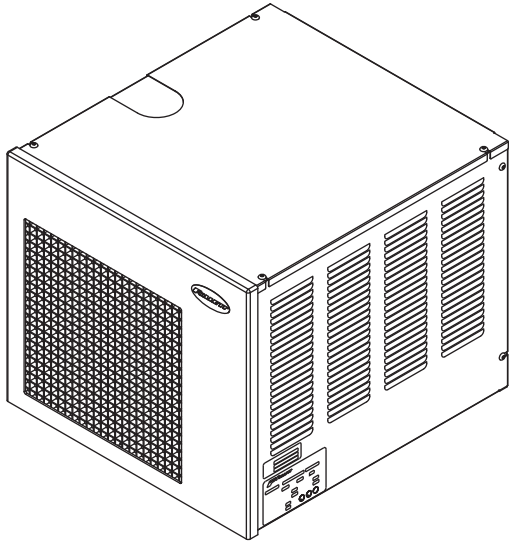
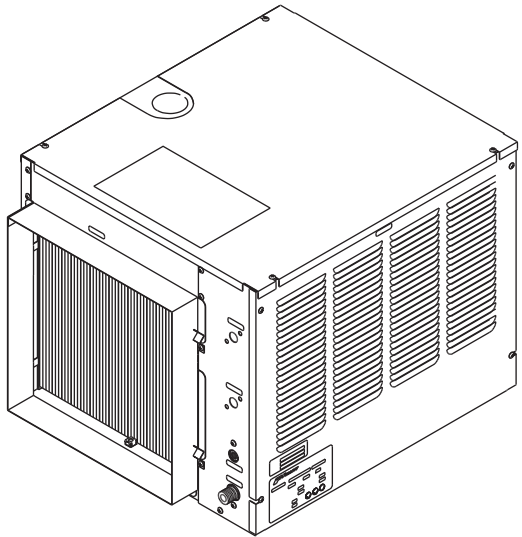

**Following installation, please forward this manual
to the appropriate operations person.**

Table of contents

Welcome to Follett Corporation	4
Specifications	5
Installation	8
Top mount icemakers (models T400A/W, MCD400A/W and MFD400A/W)	8
Satellite-fill™ icemakers (models MCD400A/W, R400A/W)	9
Ventilation	14
Ice transport tube	15
Start up	17
Operation	17
Cleaning	17
Weekly exterior care	17
Monthly condenser cleaning	18
Semi-annual evaporator cleaning	18
Service	19
Icemaker operation	19
Technical specifications	20
Refrigeration system diagram	20
Refrigeration pressure data	20
Compressor data	20
Gearmotor data	21
MCD400A/W wiring diagram	21
Electrical control system operation	22
Refrigeration system	28
Service procedures	29
Evaporator disassembly	29
Evaporator reassembly	29
Gearmotor replacement	29
Troubleshooting	30
Replacement parts	32

Welcome to Follett

Follett equipment enjoys a well-deserved reputation for excellent performance, long-term reliability and outstanding after-the-sale support. To ensure that this equipment delivers that same degree of service, we ask that you review the installation portion of this manual before beginning to install the unit. Our instructions are designed to help you achieve a trouble-free installation. Should you have any questions or require technical help at any time, please call our technical service group at (877) 612-5086 or +1 (610) 252-7301.

Before you begin

After uncrating and removing all packing material, inspect the equipment for concealed shipping damage. If damage is found, notify the shipper immediately and contact Follett Corporation so that we can help in the filing of a claim, if necessary.

Check your paperwork to determine which model you have. Follett model numbers are designed to provide information about the type and capacity of Follett equipment. Following is an explanation of the different model numbers in the 400 series.

MCD400ABT

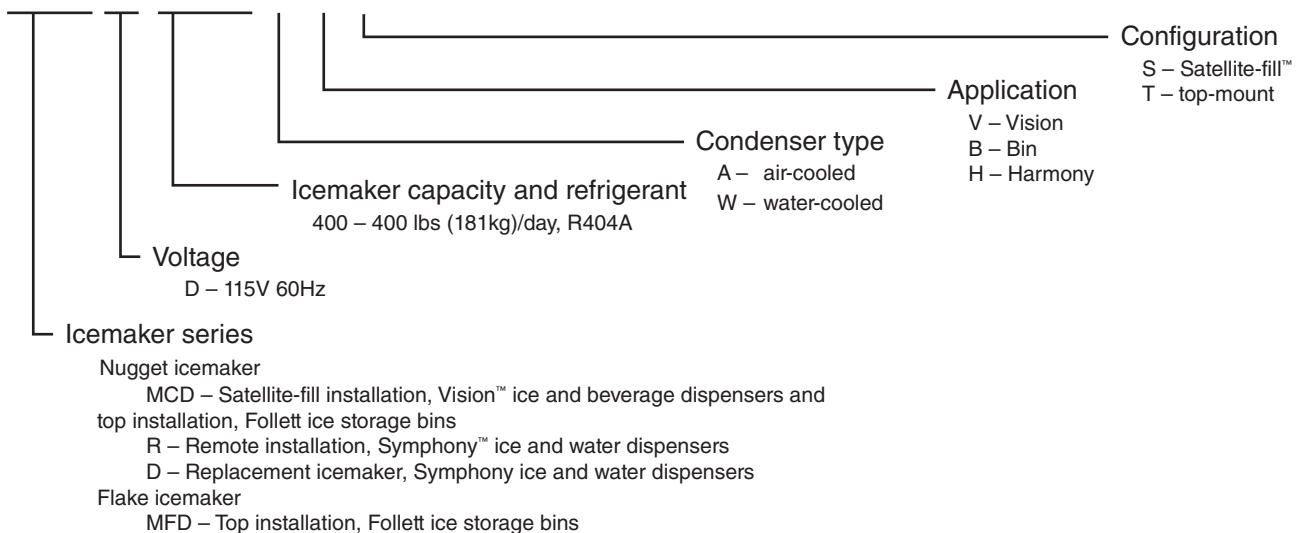

Important cautions

Moving parts. Do not operate with front cover removed.

Hot parts. Do not operate with cover removed.

To reduce risk of shock disconnect power before servicing.

Most ice machine cleaners contain citric or phosphoric acid, which can cause skin irritation. Read caution label on product and follow instructions carefully.

Ice is slippery. Maintain counters and floors around dispenser in a clean and ice-free condition.

Ice is food. Follow recommended cleaning instructions to maintain cleanliness of delivered ice.

Specifications

Electrical

Each icemaker and dispenser require a separate circuit with electrical disconnect within 10 ft (6m).

Equipment ground required.

Standard electrical – 115V, 60Hz, 1 phase.

Maximum dispenser fuse – 15 amps,

Maximum icemaker fuse – 20 amps each

Maximum icemaker amperage – 11 amps each

Cord and plug provided on icemaker and dispenser

Electrical connections

Model	Electrical connection	Circuits required
25FB400A/W, 50FB400A/W, 110FB400A/W	cord & plug provided	115/60/1, 20 amp max. fuse size
25CT400A/W, 50CT400A/W, 110CT400A/W	cord & plug provided	115/60/1, 20 amp max. fuse size
25CR400A/W, 50CR400A/W, 110CR400A/W	dispenser, icemaker and bin signal: cord & plug provided	115/60/1, (2) circuits required dispenser: 15 amp max. fuse size icemaker: 20 amp max. fuse size
VU155R400A/W, VU300R400A/W VU155BR400A/W, VU300BR400A/W VU155R400A/WX, VU155BR400A/WX	dispenser, icemaker and bin signal: cord & plug provided	115/60/1, (2) circuits required dispenser: 15 amp max. fuse size icemaker: 20 amp max. fuse size
VU155NR400A/W, UD300R400A/W VU155R800A/W, VU300R800A/W, VU155R800A/WX, VU155BR800A/W, VU300BR800A/W, VU155R800A/WX	dispenser, icemaker and bin signal: cord & plug provided	115/60/1, (3) circuits required dispenser: 15 amp max. fuse size (2) icemakers: 20 amps max. fuse size each

▲ CAUTION

- Check start relay before supplying power
- Start relay is gravity sensitive, and MUST be in “up” position
- Failure to comply may cause equipment to overheat, resulting in equipment failure, equipment damage or fire hazard

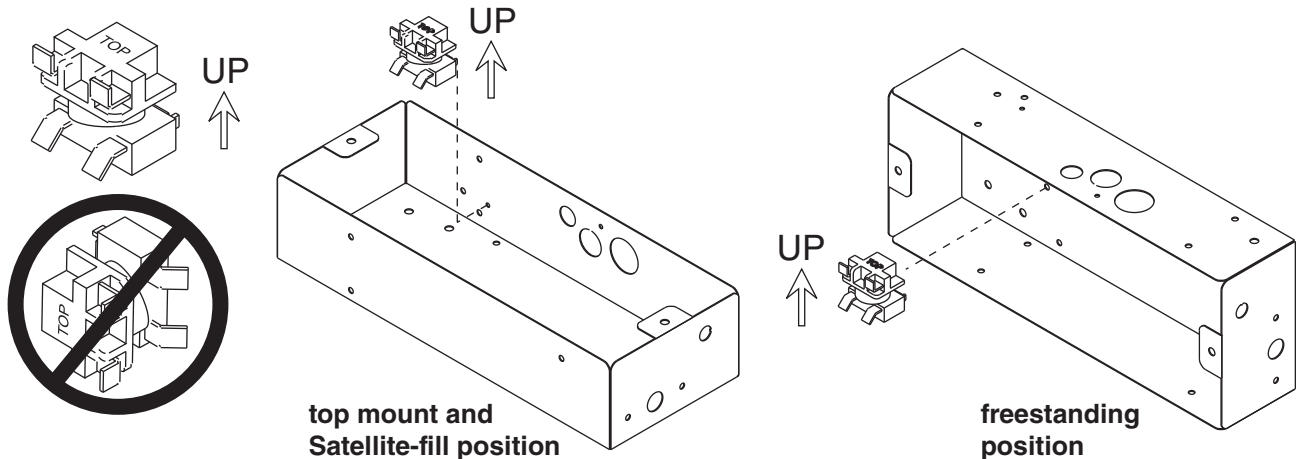

Plumbing

3/8" OD push-in water inlet

3/4" MPT drain

3/8" FPT condenser inlet (water-cooled condenser only – 1.25 gpm minimum available flow)

3/8" FPT condenser drain (water-cooled condenser only)

Notes: Slope to drain of 1/4" per foot (6mm per 30.4cm run) with a 1/2" min. is recommended.
Water shut-off recommended within 10 feet (3m), drain to be hard piped and insulated.
Separate drains for icemaker and condenser. To prevent back flow, do NOT connect drains.
Follett recommends installation of an activated carbon filter in icemaker inlet water line.

Ambient

Air temperature	100 F/38 C max.	50 F/10 C min. (best performance below 80 F/27 C)
Water temperature	90 F/32 C max.	40°F/4°C min. (best performance below 70 F/21 C)
Water pressure	70 P.S.I max. (482 kPA)	10 P.S.I. min. (89 kPA)

Dimensions and clearances

Entire front of icemaker must be clear of obstructions/connections to allow removal.

12" (305mm) clearance above icemaker for service.

6" (153mm) minimum clearance between exhaust side of icemaker and any adjacent equipment.

MCD400A & R400A – 18" (457mm) minimum, 10 ft (3m) maximum clearance between discharge and air intake grilles.

Front view — air-cooled top mount

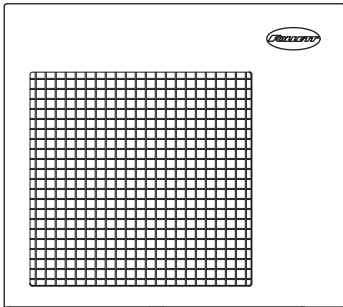

Back view — air-cooled top mount

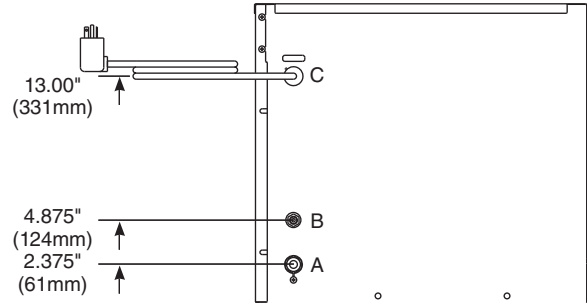

Front view — air-cooled Satellite-fill

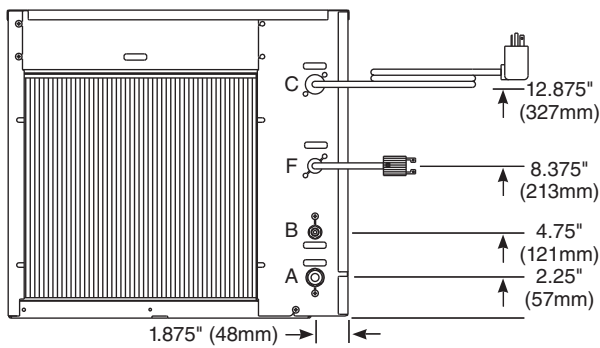

Front view — water-cooled Satellite-fill
Back view — water-cooled top mount

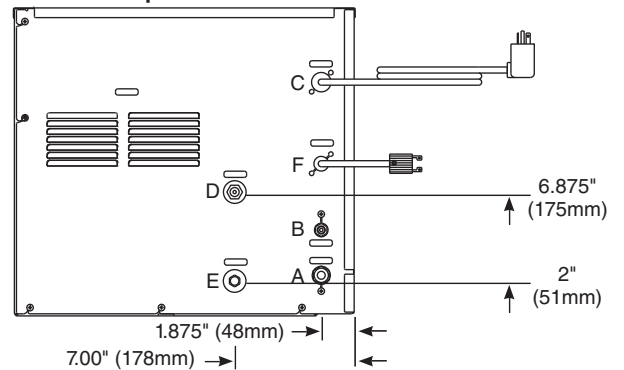

Side view — air-cooled and water-cooled top mount and Satellite-fill

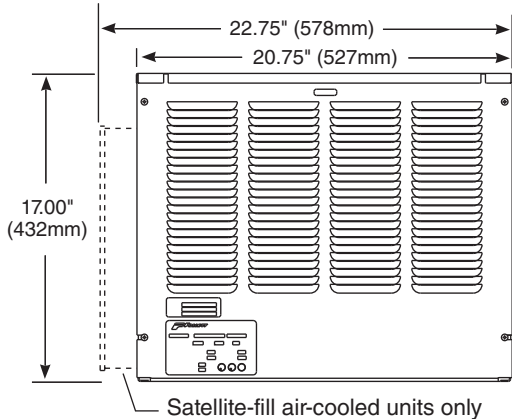

Icemaker plug configuration NEMA 5-20



- | | |
|--|-------------------------------------|
| A – 3/4" MPT drain | D – 3/8" FPT condenser inlet |
| B – 3/8" OD push-in water inlet | E – 3/8" FPT condenser drain |
| C – Electrical cord | F – Bin signal cord |

Installation

Icemaker performance is very sensitive to the quality of installation. To ensure proper performance, ease of service and warranty coverage, it is critical that you follow the requirements detailed in this manual. If you cannot meet these requirements or have questions, call our technical service group immediately at (877) 612-5086 or +1 (610) 252-7301.

Top mount icemaker on bin installation procedure (models MCD400A/WBT and MFD400A/WBT)

Install icemaker and rough-in utilities

1. Install ice storage bin in its final location.
2. Install one supplied grommet in large knockout in base of icemaker and second supplied grommet in ice hole provided in top of ice storage bin.
3. Rough in plumbing and electrical per specs provided.
4. Flush all water lines before final hook up.
5. Position icemaker with utility connections facing rear of bin.
 - A. If new storage bin and icemaker – position icemaker with connections facing rear of bin.
 - B. If using existing bin – place supplied gasket 2.5" (64mm) from front of bin (Fig. 2). Position icemaker with utility connections facing rear of bin.
6. Make final plumbing and electrical connections.
7. Working from inside bin storage area, push end of transport tube without fasteners up through grommets into icemaker, leaving about 2" (51mm) hanging down in bin.
8. Route free end of tube to evaporator port.
9. Slip a hose clamp in free end of tube.
10. Push free end of tube on evaporator port and tighten clamp, making sure clamp is positioned on evaporator side of flange (no flange on MFD400 series flake icemaker).
11. Position ice tube under float bracket retaining tab.
12. Carefully slip ice level control stat alongside transport tube through both grommets and down into bin.
13. Run ice level control stat down through one side of cap tube fasteners attached to ice transport tube, form a 180° bend at end of tube and run back up through fastener (Fig. 1).
14. Adjust loop length to provide desired ice level. Loop must below end of ice transport tube.
15. Carefully bend end of cap tube to prevent it from slipping out of clamp.

Fig. 1

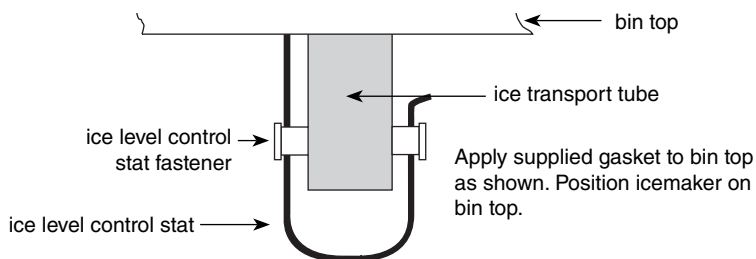
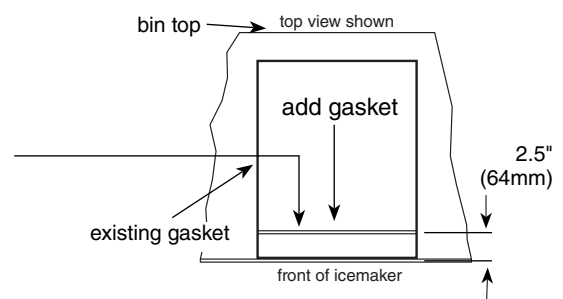

Fig. 2 – Replacing existing icemakers



Before turning power on

1. Clean and sanitize ice storage bin in accordance with cleaning procedure in ice storage bin installation information packed with ice storage bin.
2. Turn water to icemaker on.
3. Remove cover on float reservoir.
4. Push down on float to force water out overflow tube and into evaporator drain pan.
5. Check that water drains freely from evaporator drain pan.
6. Lift float and check that float valve shuts off incoming water when raised.

After turning power on

1. Turn power to icemaker on and confirm that gearmotor, compressor and fan motor start immediately.
2. Check that ice begins to enter bin within approximately 10 minutes.
3. With icemaker running, check that float reservoir water level is approximately 3/8" (10mm) below internal overflow and adjust to this level (raised line on side of reservoir) if necessary.
4. After making ice for 10 minutes, put ice against ice level control stat cap tube and check that icemaker shuts down.
5. Warm ice level control stat with your fingers and check that icemaker restarts in approximately 20 minutes. (Bin must be calling for ice.)

Satellite-fill icemaker installation procedure (models MCD400A/WH and MCD400A/WVS)

Satellite-fill icemaker performance is very sensitive to the quality of installation. To ensure proper performance, ease of service and warranty coverage, it is critical that you follow the requirements detailed in this manual. If you can not meet these requirements or have questions, call our technical service group immediately at (877) 612-5086 or +1 (610) 252-7301.

Installing Satellite-fill icemaker and rough-in utilities without optional slide-out accessory

The requirements below are for icemaker installation without the Follett slide-out accessory. These procedures ensure that the icemaker can be easily removed as one unit for cleaning and maintenance. For installation with the slide-out accessory, refer to instructions to install icemaker and rough-in utilities with optional slide-out accessory.

General requirements

- Front of icemaker free of obstructions, plumbing lines, electric conduits.
- 12" (305mm) minimum clearance above icemaker for access to icemaker components.
- 6" (153mm) minimum clearance between exhaust side of icemaker and adjacent equipment.
- Do NOT weld icemaker to counter channels.
- Large, removable panels in counter face to allow icemaker removal.
- Machine stand accessory required for icemakers not supported on counter channels.

Connection requirements

- Compression fittings for water and drain lines.
- Separate drains for condenser and icemaker. Do NOT connect drains.
- 20 amp power supply with 6 feet.

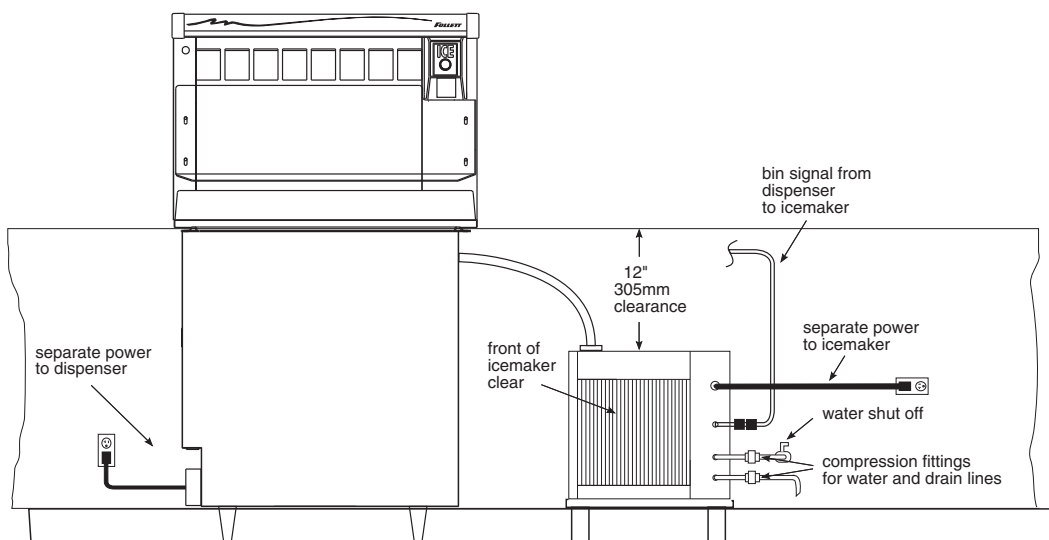

Note: Diagram intended as guide only. All field wiring to be installed in accordance with NEC and local electrical codes.

Field wiring diagrams for Satellite-fill icemaker installations

All field wiring must be installed in accordance with NEC and local electrical codes.

Field wiring diagram is intended only to aid electrician or technician in understanding how equipment works.

Should local codes require a hard-wired connection and/or shielded wiring, eliminate the cord and plug(s) and follow the appropriate field wiring diagram.

MCD400A/W and R400A/W icemakers have separate power supply from dispenser.

Electric disconnects required within 10 ft (3m) for all hard-wired connections.

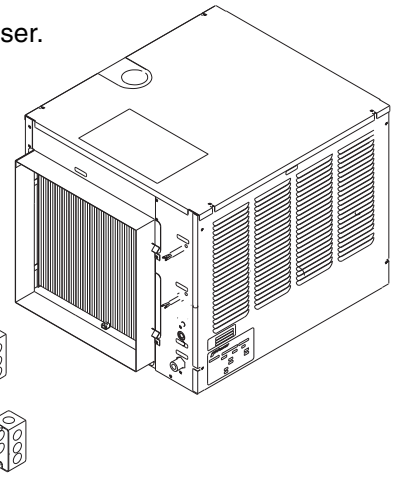

Recommended junction box preparation of hard-wired Satellite-fill icemakers.

1. Cut plugs from supplied power cords.
2. Replace upper (power) strain relief with a cord connector.
3. Mount two 2" x 4" junction boxes using supplied holes in icemaker face.
4. Make power and bin signal connections.

25, 50 or 110 ice and water dispenser with ONE Satellite-fill icemakers (dispenser models 25CR400A/W, 25HR400A/W, 50CR400A/W, 50HR400A/W, 110CR400A/W)

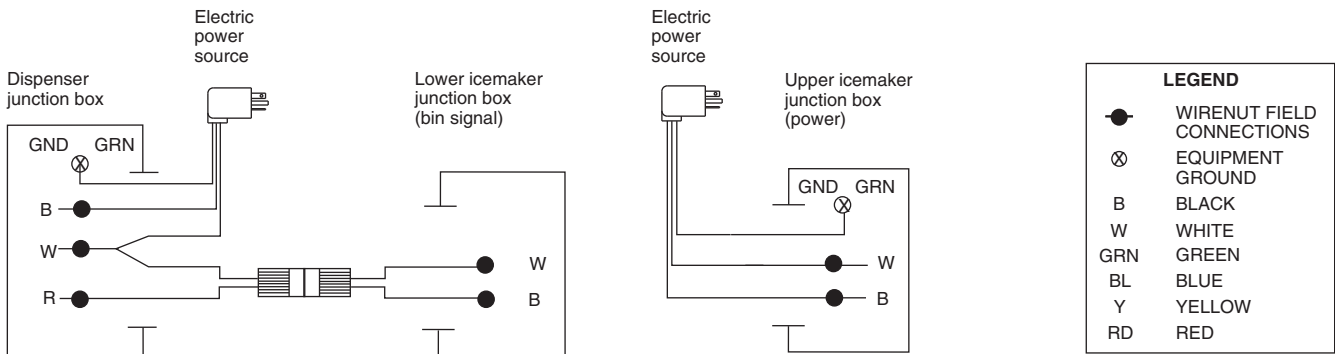

VU155/VU300 ice and beverage dispenser with either ONE or TWO Satellite-fill icemakers

Note: 24V bin signal; Verify black bin signal wire is on the 24V terminal

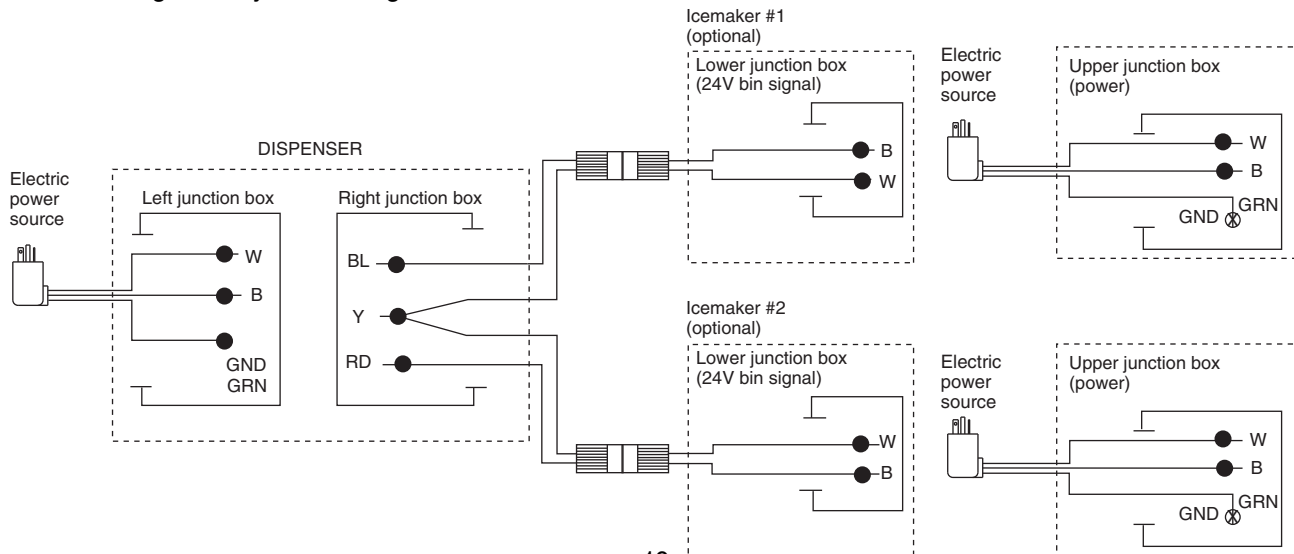

Installing Satellite-fill icemaker and rough-in utilities with optional slide-out accessory

The slide-out accessory allows the icemaker to be pulled out on a track from below a counter without disconnecting utilities. A leg supports the icemaker in the full-out position. If your order did not include a slide-out accessory proceed to icemaker ventilation and exhaust.

Step 1 – Installing track accessory (Follow either A or B below for Satellite-fill icemaker)

Track must be positioned flush against inside of counter and slightly above counter access opening.

A. When icemaker stand is used (required if icemaker is not supported on counter channels)

1. Bolt vertical utility panel to slide-out track assembly with supplied 10/32 screws.
2. Secure slide-out track assembly to icemaker stand with 10/32 screws provided.
3. Position icemaker stand in desired location and adjust stand legs to proper height and level in both directions.
4. Using holes in flanged legs as template, mark floor for 12 anchoring holes to be drilled.
5. Remove stand/track assembly and drill marked holes.
6. Reposition and anchor stand to floor with 12 fasteners appropriate to floor material (not supplied).

Stand MUST be anchored to avoid tipping and possible injury when icemaker is pulled out.

B. When icemaker is supported on counter channels

1. Bolt vertical utility panel to slide-out track assembly with supplied 10/32 screws.
2. Position track assembly on counter channels (Fig. 3).
3. Using holes in track assembly as a template, mark and drill required holes in counter channels.
4. Remove track assembly on channels and drill marked holes.
5. Reposition track assembly on channels and secure using appropriate hardware (not supplied).

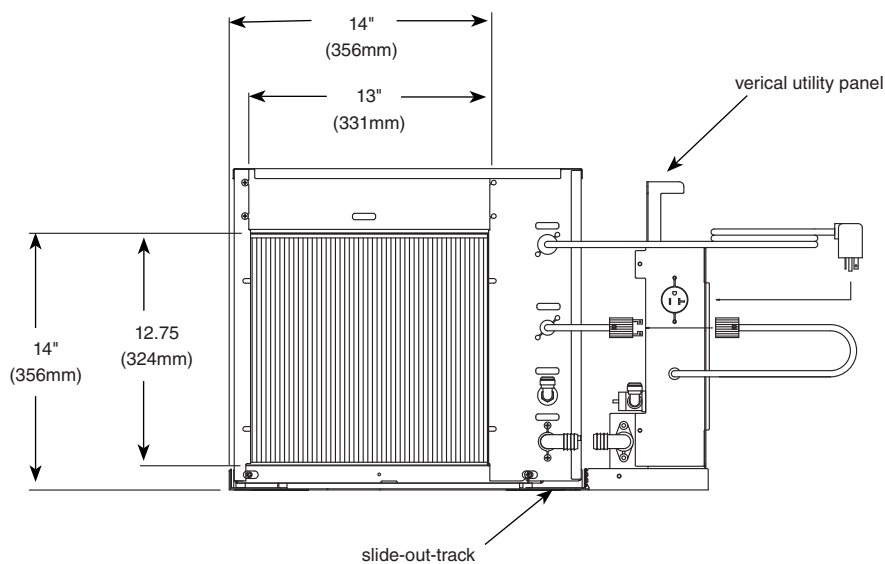

Step 2 – Installing Satellite-fill icemaker on slide-out track

A. When icemaker is shipped with slide-out track accessory (follow either A or B)

1. Connect inlet water, drain, and power supply to back of vertical utility panel.
2. Place icemaker on slide-out track assembly.
3. Connect drain and water lines.
4. Connect electrical plugs from icemaker to utility panel.

B. When icemaker is installed in and shipped with counter

1. Remove two outer rear screws from icemaker and install supplied spacer and screw (Fig. 3).
2. Place icemaker on slide-out track assembly.
3. Connect drain and water lines.
4. Connect electrical plug from icemaker to utility panel.
5. Remove pin from adjustable leg.
6. Place hold-down strap over leg block and secure strap to slide-out assembly with supplied screws (Fig. 4).
7. Reinstall pin in leg block.
8. At job site remove hold-down strap and make utility connections at rear utility panel.

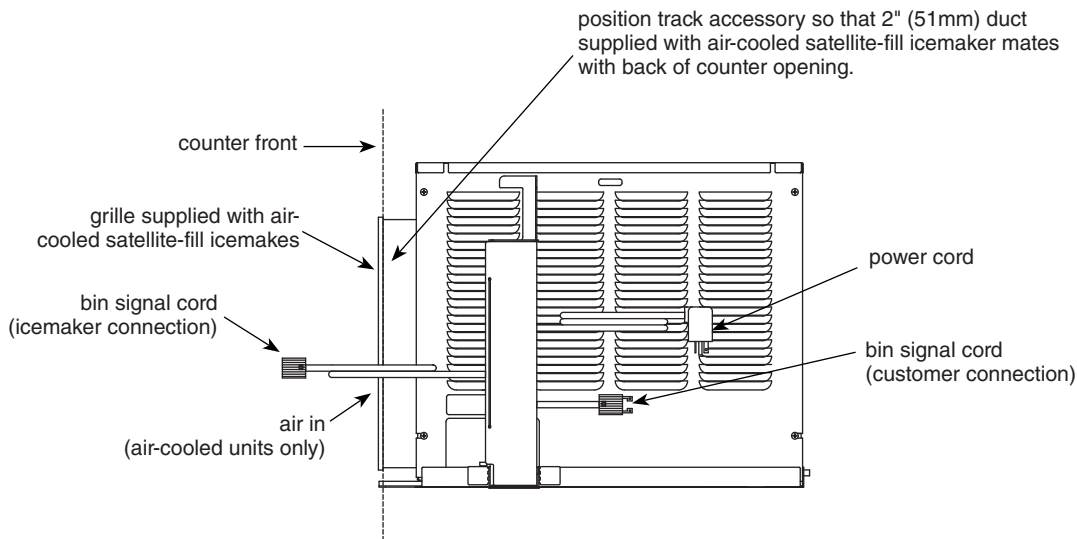

Fig. 3

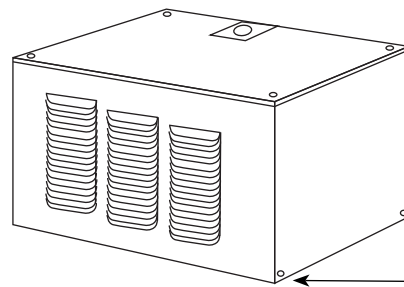
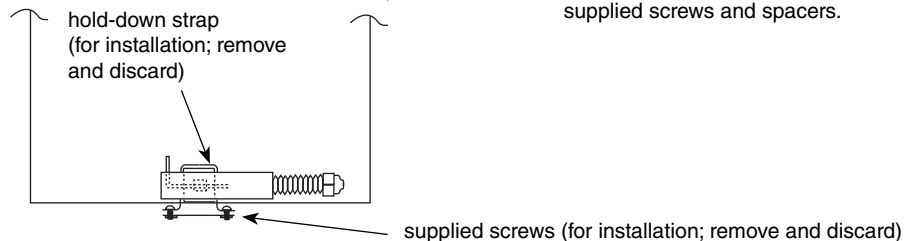
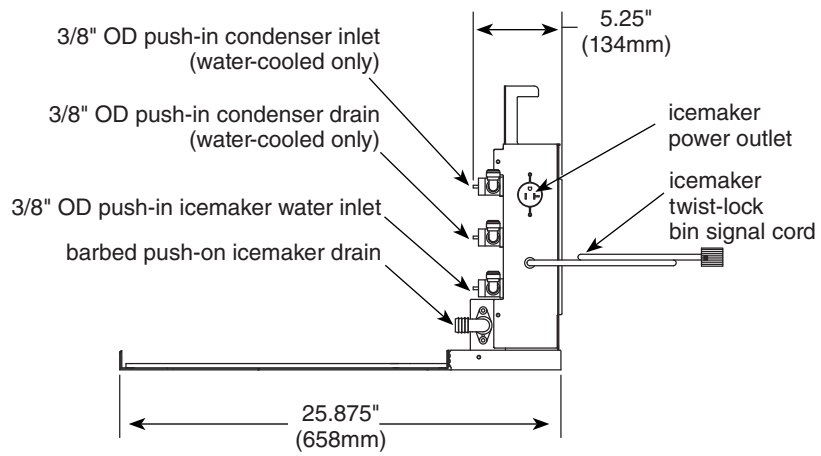

Fig. 4



Front view



Side view

(All customer field connections are made to rear of vertical utility panel)

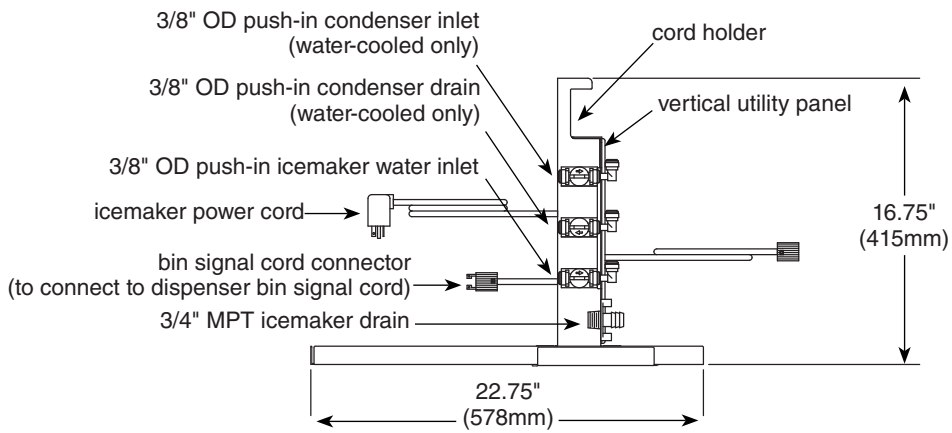

Plan view

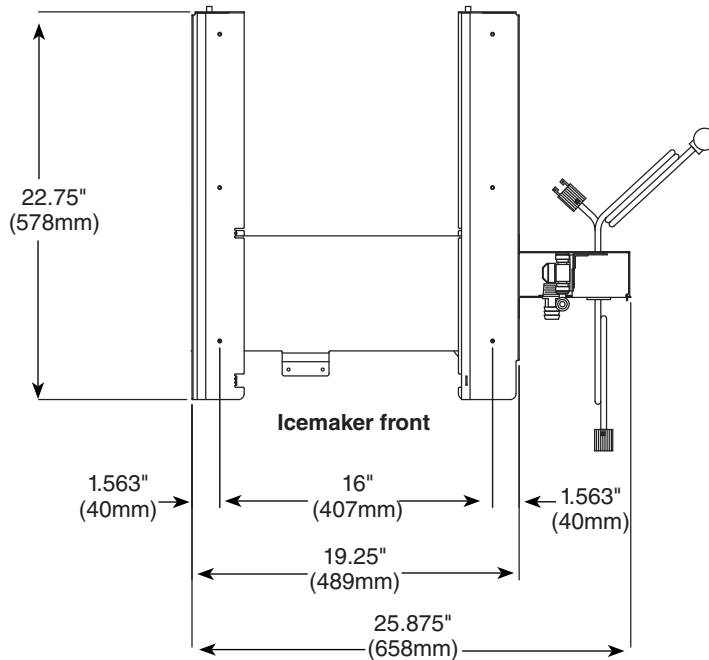

Satellite-fill icemaker ventilation and exhaust requirements

Fabricator-supplied, custom air intake grilles must have 12" x 12" (305mm x 305mm) opening yielding 100 sq. inches (645 sq. cm) of open air space within duct perimeter. Block off any open area outside of the air duct.

Intake air requirements — air-cooled icemakers (MCD400AHS, MCD400AVS & R400A only)

1. Check that 2" (51mm) duct is installed on condenser front.
2. Cut a 12" x 12" (305mm x 305mm) opening in counter face to align with duct.
3. Position icemaker to mate duct flush with back of counter opening.
4. Install supplied grille on outside of counter opening.

Exhaust air — all icemakers (MCD400A/W & R400A/W)

Provide 100 sq. in. (645 sq. cm) of counter opening for exhaust air at least 18" (457mm) from intake opening but not more than 10 ft (3m) away.

MCD400AHS, MCD400AVS & R400A — Side View

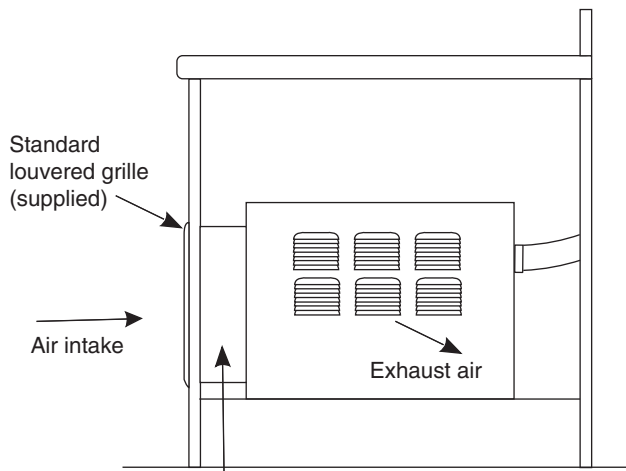

Supplied 2" (51mm) duct **MUST** be installed to front of icemaker and mated flush to inside of counter face opening.

Front View

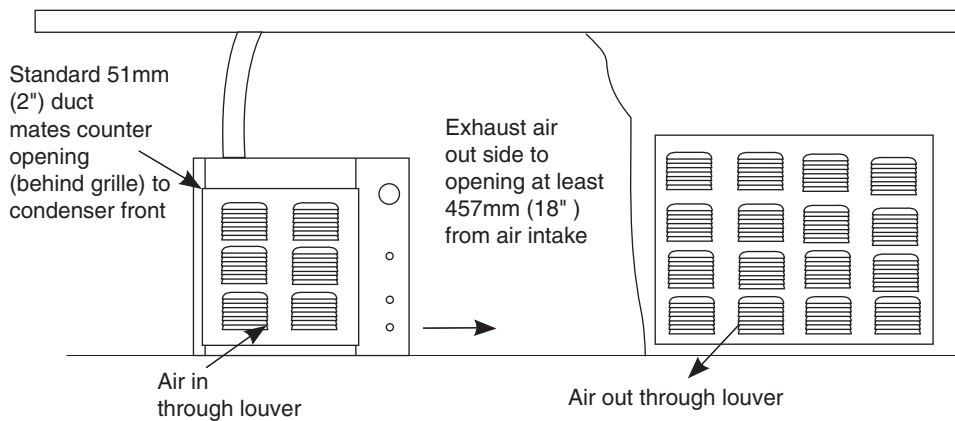

Provide at least 645 sq. cm (100 sq. inches) of counter opening for exhaust air

Satellite-fill icemaker ice transport tube installation

Incorrect ice transport tube installation can result in wet ice and dispensing problems. Follow guidelines below to ensure correct installation. Call factory for assistance if you are unable to meet these requirements.

General requirements

Maximum length of tube run – 20 ft (6m). Factory approval required for longer runs.

Run tube without dips.

One continuous length of tube; no splices.

Minimum radius of bends in tube – 6" (153mm) inside radius.

Maximum number of bends – 6.

Insulation on entire run of ice tube.

Procedure

1. If installing MCD series icemaker refer to additional connection specifications for Vision series ice and beverage dispensers instructions below.
2. Select side, rear or top knockout in icemaker cabinet for tube entrance.
3. Install supplied grommet in knockout.
4. Remove icemaker top panel.
5. Install supplied insulation on entire length of tube.
6. Run insulated tube without dips between icemaker and dispenser and secure in place.
7. Cut insulation off tube where tube enters grommet.
8. Slide end of tube without insulation through grommet and run to evaporator port.
9. Cut tube to that length.
10. Install a section of insulation on tube from grommet to evaporator port.
11. Slip supplied hose clamp over free end of tube.
12. Pull insulation back from free end of tube.
13. Push tube on evaporator port.
14. Position clamp behind lip on evaporator port and tighten clamp.

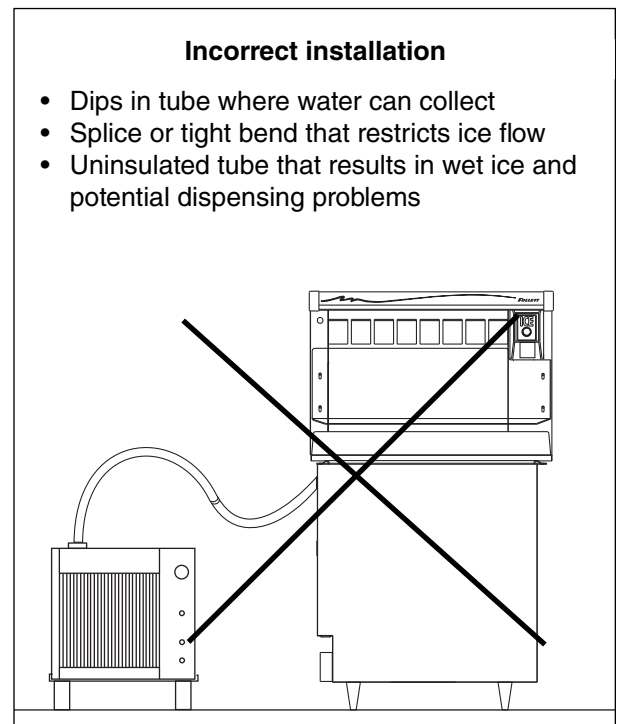
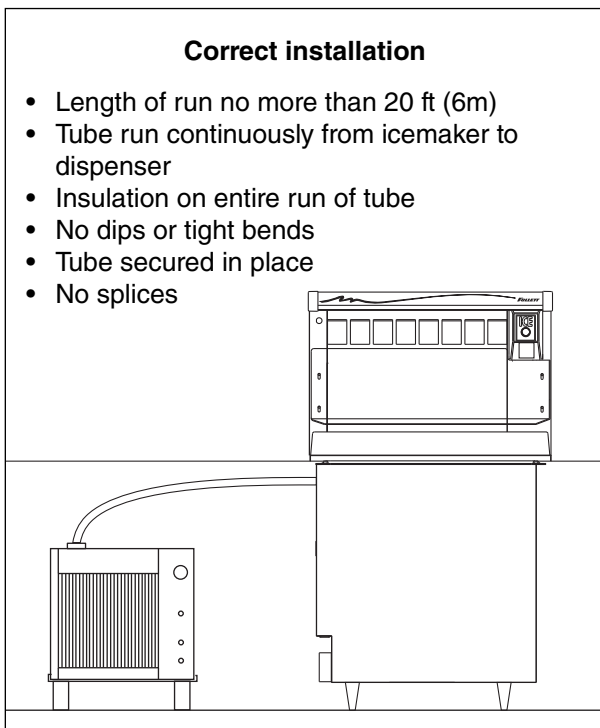

Additional ice transport tube connection specifications for Vision series ice and beverage dispensers

Check to make sure bin signal on icemaker control board is switched to 24 volt connection.

1. Push one end of ice transport tube(s) through hole(s) provided in side of dispenser.
2. Route tube into ice tube bracket inside dispenser and engage bracket tabs in holes located in end of ice transport tube(s) (see drawings below).
3. Verify bin thermostat capillary tube is mounted correctly (see drawings below).

Ice tube retainer bracket

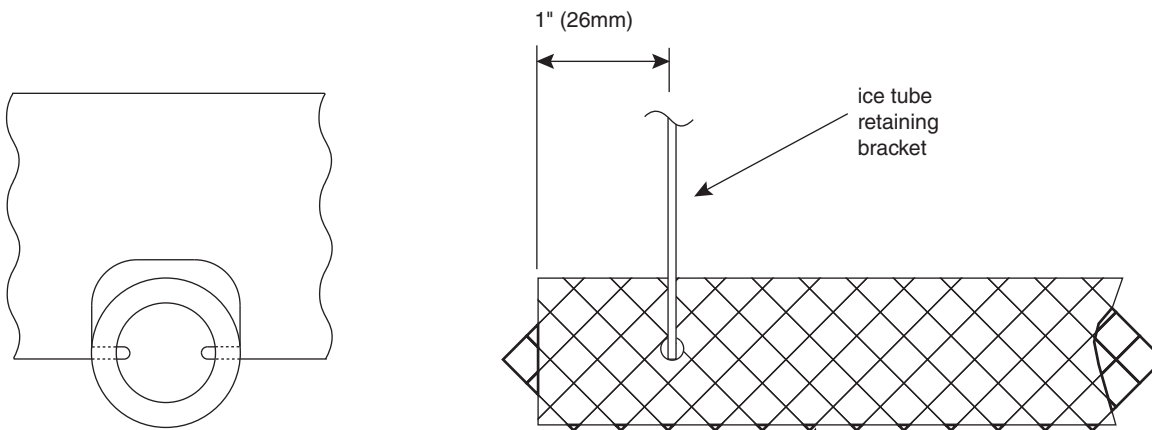

Bin thermostat capillary tube mounting

Front View, VU155

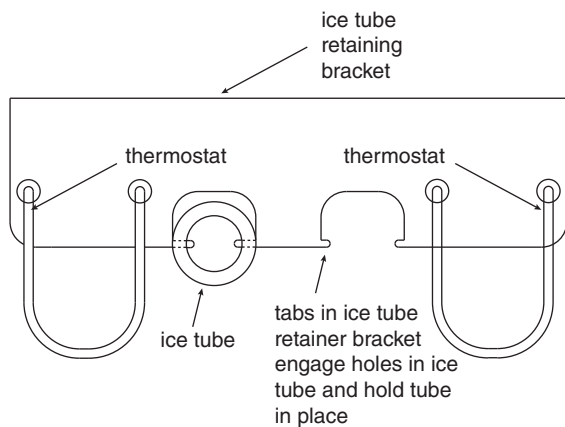

Front View, VU300

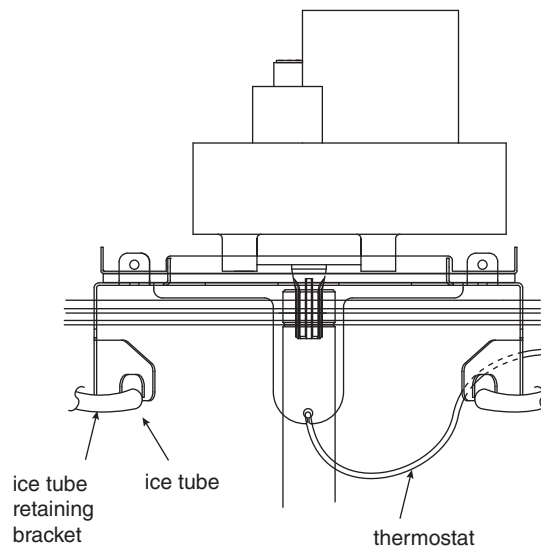

Ice transport tube installation detail

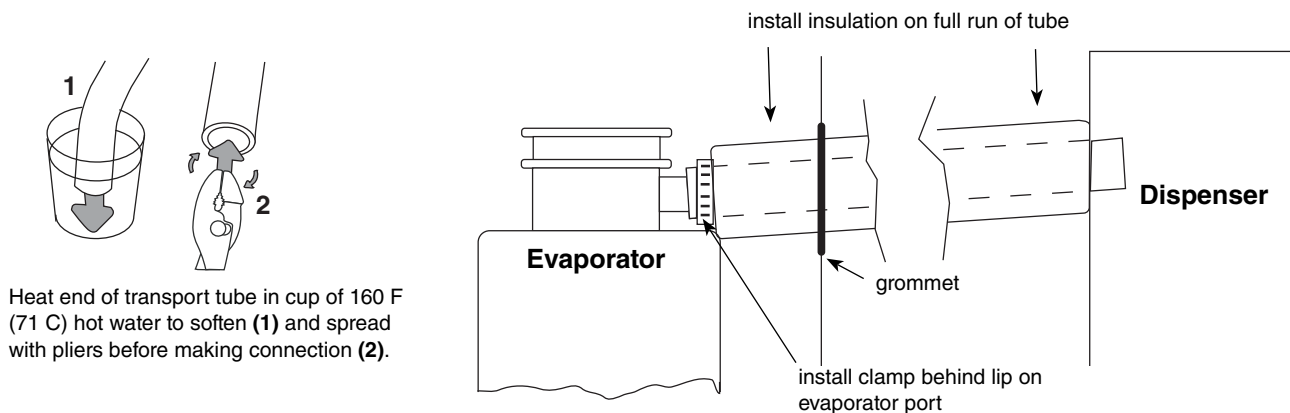

Satellite-fill icemaker start up procedure

The start-up procedure below is intended to ensure that icemaker is operating properly after installation has been made. Check each item listed and call factory immediately for assistance if you experience problems with unit.

Before turning on power

1. Turn on water to icemaker.
2. Push down on float to force water through overflow chamber into evaporator drain pan and check for proper drainage of drain pan.
3. Check that float valve shuts off incoming water when raised.
4. Check that hose clamp securely holds ice transport tube on evaporator port.

After turning on power

1. Turn on power to icemaker and confirm that gearmotor, fan motor and compressor start immediately.
2. Check that ice begins to enter dispenser bin area within approximately 10 minutes.
3. Check that float reservoir water level is approximately 3/8" (.95mm) below overflow during icemaker operation and adjust to this level if necessary.
4. Put ice against bin level thermostat in dispenser bin and check that compressor and fan motor shut down approximately 10 seconds after thermostat opens. Gearmotor should run for an additional 60 seconds.
5. Check that icemaker comes back on in approximately 20 minutes (bin signal must be present).

Operation

Cleaning and preventive maintenance (all models)

Preventive maintenance

Periodic cleaning of Follett's icemaker system is required to ensure peak performance and delivery of clean, sanitary ice. The recommended cleaning procedures that follow should be performed at least as frequently as recommended and more often if environmental conditions dictate.

Cleaning of the condenser can usually be performed by facility personnel. Cleaning of the icemaker system, in most cases, should be performed by your facility's maintenance staff or a Follett authorized service agent. Regardless of who performs the cleaning, it is the operator's responsibility to see that this cleaning is performed according to the schedule below. Service problems resulting from lack of preventive maintenance will not be covered under the Follett warranty.

Weekly exterior care

The exterior may be cleaned with a stainless cleaner such as 3M* Stainless Steel Cleaner & Polish or equivalent.

* 3M is a trademark of 3M Company.

Monthly condenser cleaning (air-cooled icemaker only)

1. Use a vacuum cleaner or stiff brush to carefully clean condenser coils of air-cooled icemakers to ensure optimal performance.
2. When reinstalling counter panels in front of remote icemakers, be sure that ventilation louvers line up with condenser air duct.

Semi-annual evaporator cleaning (every 6 months)

Solution A – Ice machine cleaner: Prepare one gallon (3.8L) of Follett SafeCLEAN™ Ice Machine Cleaner (one 7 oz packet) or equivalent. Solution temperature must be at least 120 F (49 C).

Warning: Most ice machine cleaners contain citric or phosphoric acid that can cause skin irritation. Read caution label on product and follow instructions carefully.

Solution B – Sanitizing solution: Prepare 2 gallons (9L)

Combine 1 oz (30ml) bleach with 2 gal (8L) hot water (at least 120 F (49 C)) or a 5.25% sodium hypochlorite solution.

1. Remove icemaker panels required to gain access to water reservoir components (Fig. 5) and electrical control box.
2. Turn compressor switch on electrical box to OFF position.
3. Dispense all ice from dispenser.
4. Shut off water to icemaker.
5. Drain water from reservoir through float/evaporator drain line (Fig. 5.1). Reinsert hose into hose clip (Fig. 5.3).
6. Fill reservoir and evaporator (Fig. 5.2) with Solution A.
7. Verify compressor switch is in the off position. Restart icemaker and allow gearmotor to run for 15 minutes.
8. While waiting 15 minutes, follow steps 8a through 8c.
 - a) Remove ice compression nozzle (Fig. 6.1). Soak in Solution A.
Note: No compression nozzle on MFD400 series flake icemaker.
 - b) Descale drain pans (Fig. 6.2) by grasping firmly and gently bending up and down. Vacuum residue out.
 - c) Inspect all drain lines. Clean as necessary with Solution A (Fig. 5).
9. Disconnect icemaker power.
10. Drain Solution A through float/evaporator drain line (Fig. 5.3). Rinse evaporator by filling reservoir (Fig. 5.2) with potable water and draining evaporator through float/evaporator drain line (Fig. 5.3) three times. Reinsert hose into hose clip (Fig. 5.3) and insert plug into end of drain line (Fig. 5.1).
11. Connect ice transport tubes (Fig. 6.3) directly to evaporator outlet ports (without ice compression nozzle) (Fig 6.4).
12. Fill reservoir and evaporator (Fig. 5.2) with Solution B.
13. Rinse ice compression nozzle in clear water and submerge in cup of Solution B while performing steps 14 through 16.
14. Turn on bin signal switch in electrical box to allow gearmotor to run.
15. Wait 10 minutes. Turn compressor switch on.
16. Keep reservoir (Fig. 5.2) full of Solution B while making ice for 20 minutes.
17. Turn compressor switch off.
18. Rinse ice compression nozzles (Fig. 6.1) with water and reinstall.
Note: No compression nozzles on MFD400 series flake icemaker.
19. Drain any remaining sanitizing solution from reservoir through float/evaporator drain line (Fig. 5.1).
20. Fill reservoir (Fig. 5.2) with 120 F (49 C) water. Empty water through float/evaporator drain line (Fig 5.3). Repeat 3 times.
21. Turn on water to icemaker.
22. Turn compressor switch on.
23. Replace reservoir cover and any panels removed to clean icemaker.
24. Make ice for 30 minutes. Dispense and discard all ice.
25. Clean and sanitize dispenser as outlined in dispenser operation and service manual.

Fig. 5

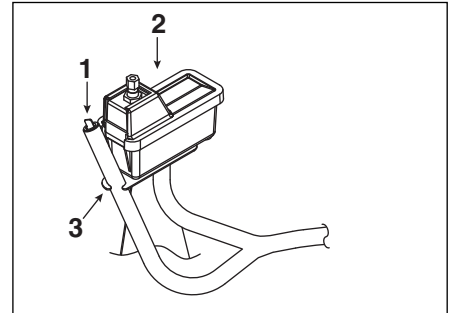
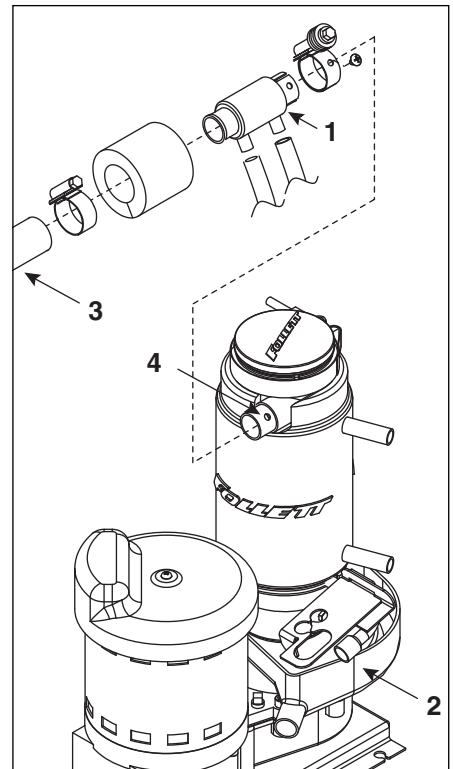

Fig. 6



Service

Icemaker Operation (all models)

Follett's icemaker consists of four distinct functional systems:

- Refrigeration system
- Water system
- Harvesting system
- Electrical control system

These four systems work together to accomplish the production and harvesting of ice. A problem in any one of these systems will result in improper operation of the entire ice production cycle. When troubleshooting the icemaker, it is important to analyze the entire system operation to determine which system is not functioning properly, then pinpoint the component within that system that is malfunctioning. Determine what corrective action must be taken before making any adjustments or replacing any components.

The icemaking process

The Follett icemaker uses a stainless steel jacketed evaporator and operates on a continuous freezing cycle. Water is supplied to the evaporator from the water reservoir where the water level is controlled by a float valve. This valve also shuts off the water supply when the icemaker is not running.

When the icemaker is running, a layer of ice forms on the interior surface of the evaporator. This ice is continuously removed by a slowly rotating (12 RPM) auger. The auger carries the ice upward into the cavity formed by the top bearing housing and the compression loop, where it is compressed to remove excess water. When the ice reaches the desired hardness it rotates within the cavity and is forced through a discharge port and compression nozzle and into the ice transport tube. The discharge tube and compression nozzle are slightly restricted to further compress the ice and produce the desired hardness. **Note:** MFD series flake icemakers have no compression nozzle. As the formation of ice continues, ice in the transport tube is pushed through the tube to the storage compartment in the ice dispenser or ice storage bin.

A solid state control board located in the electrical box of the icemaker controls the normal operation of the icemaker and monitors gearmotor torque. This control board will shut down the icemaker should an over-torque condition occur. It is very important that you familiarize yourself with the operational sequences detailed in this manual before attempting to service the icemaker.

Harvest system diagram

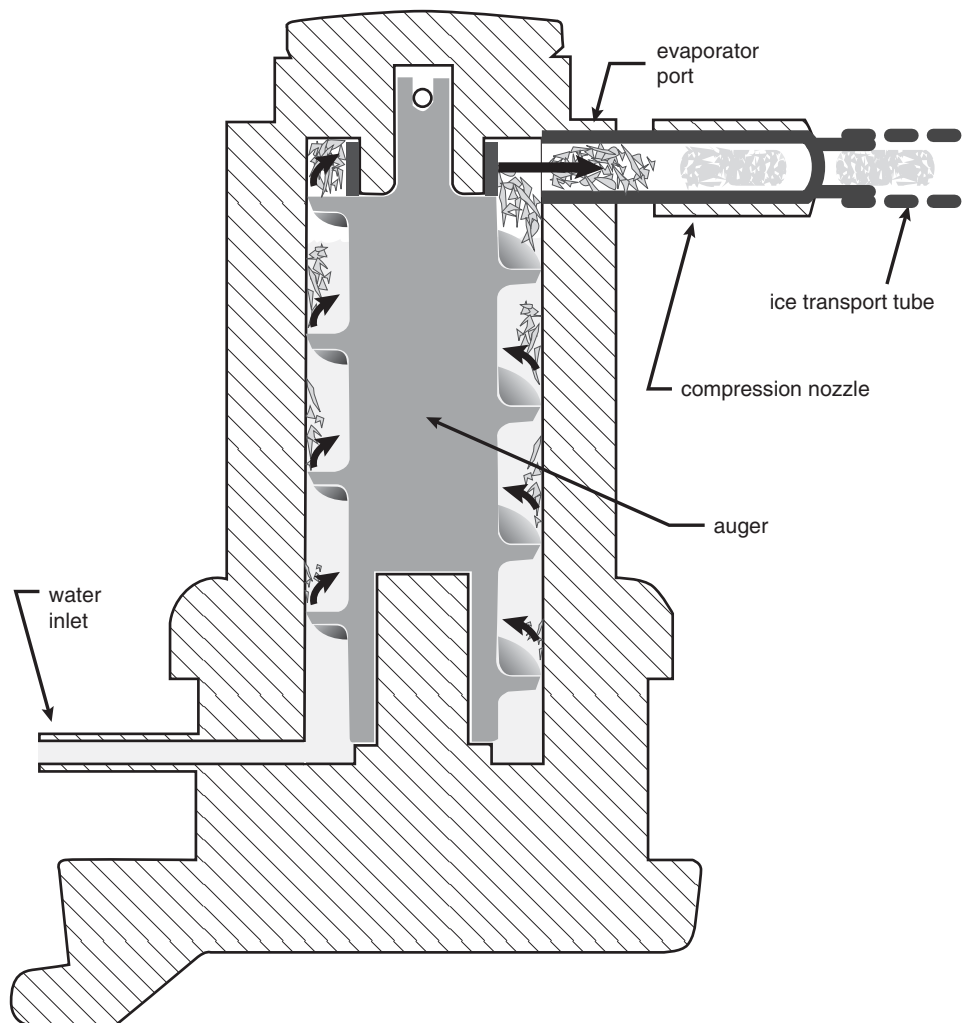

Technical specifications (all models)

Refrigeration system diagram

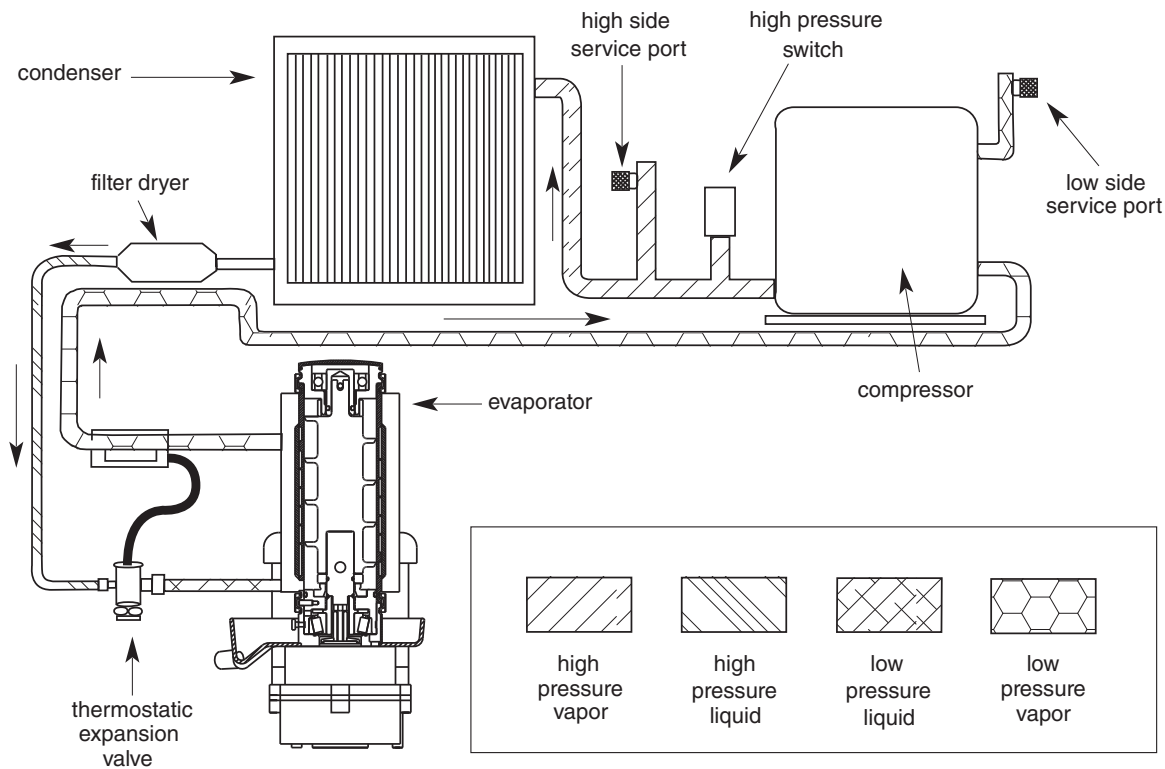

Refrigeration pressure data

- Notes: 1) Water regulating valve is factory set at 225 PSIG head pressure.
 2) Readings within 10% of above table values should be considered normal.

Air-cooled Icemaker Refrigeration Pressure

Discharge Pressure/Suction Pressure

Ambient air temperature °F/°C		°F/°C			
		60/16	80/27	100/38	
Icemaker inlet water temperature °F/°C	50/10	174/23	245/31	237/37	psi
	70/21	174/23	244/30	326/38	psi
	90/32	190/25	265/32	347/40	psi

Water-cooled Icemaker Refrigeration Pressure

Discharge Pressure/Suction Pressure

Condenser inlet water temperature °F/°C		°F/°C			
		50/10	70/21	90/32	
Icemaker inlet water temperature °F/°C	50/10	236/28	235/29	250/34	psi
	70/21	237/28	230/30	250/34	psi
	90/32	236/28	235/30	250/34	psi

Compressor data

Compressor current draw

Air-cooled

Ambient air temp.	60 F/15.6 C 6.3A	70 F/21.1 C 6.5A	80 F/26.7 C 6.7A	90 F/32.2 C 6.9A	100 F/37.8 C 7.1A
-------------------	---------------------	---------------------	---------------------	---------------------	----------------------

Water-cooled

Water temp. at float	50 F/10 C 6.6A	60 F/15.6 C 6.7A	70 F/21.1 C 6.7A	80 F/26.7 C 6.8A	90 F/32.2 C 6.9A
----------------------	-------------------	---------------------	---------------------	---------------------	---------------------

Locked rotor amps	58.8
--------------------------	-------------

Air-cooled icemaker capacity/24 hrs.

		Ambient Air Temperature °F/°C						
		F	60	70	80	90	100	
		C	16	21	27	32	38	
Inlet Water Temperature °F/°C	50	510	454	397	335	273	lbs.	
	10	232	206	180	152	124	kg.	
	60	482	435	389	329	270	lbs.	
	16	219	198	177	150	123	kg.	
	70	454	417	380	323	266	lbs.	
	21	206	190	173	147	121	kg.	
	80	424	385	347	297	247	lbs.	
	27	193	175	158	135	112	kg.	
	90	394	354	313	270	227	lbs.	
	32	179	161	142	123	103	kg.	

Water-cooled icemaker capacity/24 hrs.

Performance with new RG Group 1/2 ton coil
(Note: Data expressed in lbs/hr and kg/hr)

		Ambient Air Temperature °F/°C						
		F	60	70	80	90	100	
		C	16	21	27	32	38	
Inlet Water Temperature °F/°C	50	451	447	442	437	428	lbs.	
	10	204	202	200	199	194	kg.	
	60	423	413	409	399	394	lbs.	
	16	192	187	185	181	179	kg.	
	70	394	390	380	371	361	lbs.	
	21	179	177	172	168	163	kg.	
	80	371	361	352	342	333	lbs.	
	27	168	163	160	155	151	kg.	
	90	352	342	333	323	309	lbs.	
	32	160	155	151	146	140	kg.	

Note: Nominal values – actual production may vary by ± 10%

Gearmotor data

Gearmotor current	2.25A (nominal)
Locked rotor amps	14 amps

Electrical control system operation

MCD400A/WBT, MCD400A/WHT and MFD400A/WBT wiring diagram

Follett icemakers used on top of an ice storage bin have a slightly different circuitry. A diagram for these icemakers is shown below. The operational and diagnostic stages for these icemakers will be otherwise the same as the following stages 1 - 10.

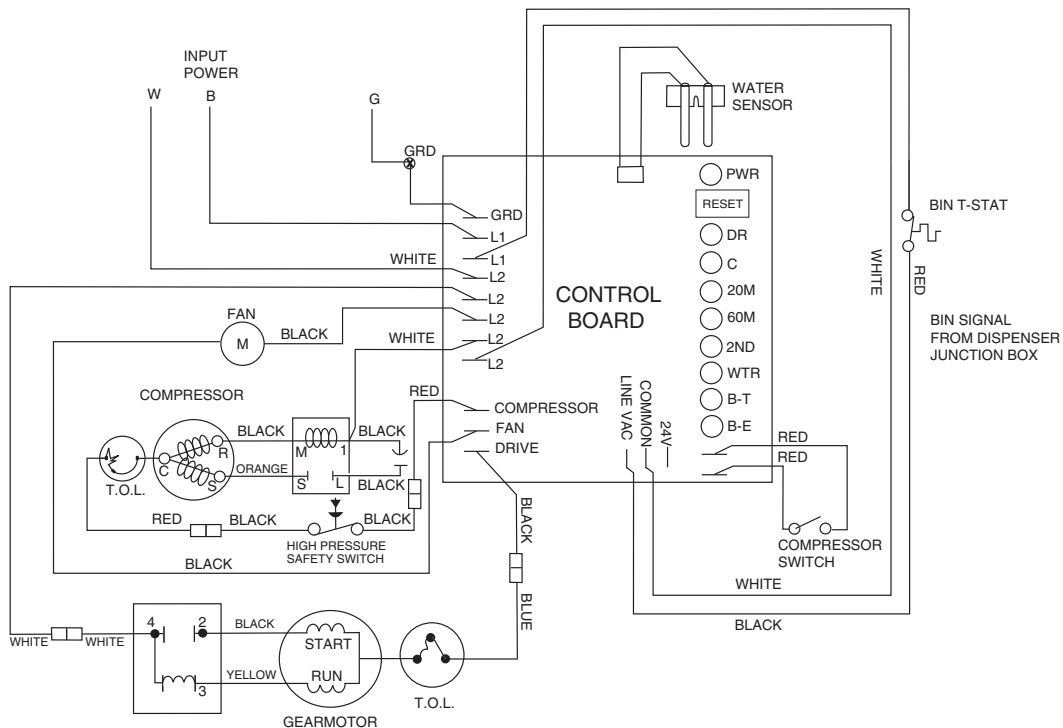

Electrical control system operation

The D400A/W, MCD400A/WVS and R400A/W wiring diagrams which follow illustrate the circuitry of Follett icemakers used with ice dispensers. Both normal operation of the icemaker (Stages 1 - 6) and non-normal diagnostic sequences showing torque-out (Stages 7 - 10) for use in troubleshooting icemaker problems are shown.

Follett icemakers used on top of an ice storage bin have a slightly different circuitry. The operational and diagnostic stages for these icemakers will be otherwise the same as Stages 1 - 10 that follow.

Circuitry notes

When the icemaker is used with a dispenser it receives power from two sources – the main power supply and the bin control signal power from the dispenser. Disconnect both power sources before performing service. When performing electrical service, always use a meter to determine whether or not the components being serviced are energized.

High pressure cutout opens at 425 PSI and closes at 287 PSI (auto reset).

Compressor switch should read open in on position.

Compressor start relay is position sensitive. See label on start relay for proper orientation.

Bin signal may be 120V, 60Hz; 230V, 50Hz; or 24V, 60Hz. If bin signal is 24V, 60Hz, black bin signal wire must be moved from LINE VAC terminal to 24V terminal.

Flashing water LED at any time indicates that water signal to board had been lost for more than one second.

Ten-second delay: There is a 10 second delay in reaction to loss of water (WTR) or bin (B-E) signals. If signals are not lost for more than 10 seconds, no reaction will occur.

Normal operation – Stage 1

Power is supplied to L1 of the control board. The ice level control in the dispenser is closed and calling for ice, supplying signal voltage to the control board. The control board will now go through the start-up sequence. Less than 30 seconds will elapse as the water sensor located in the float reservoir checks for water in the reservoir. The Bin Empty LED (B-E) will be on.

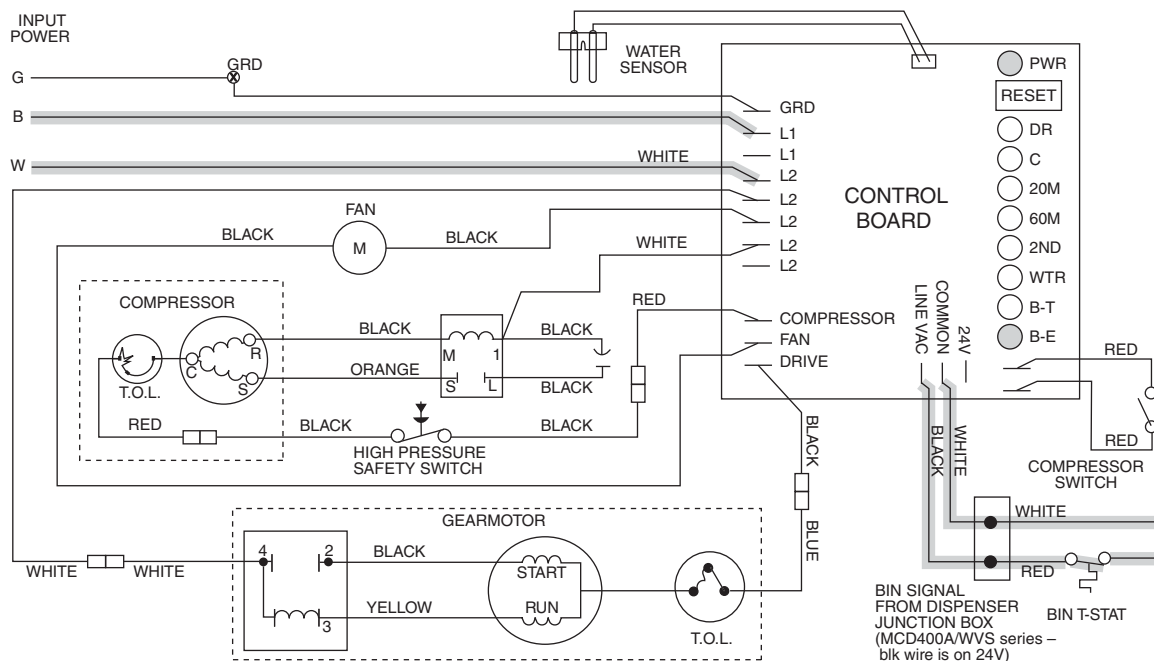

Normal operation – Stage 2

The water sensor verifies water in the float. The Water OK LED (WTR) comes on. At the same time, the gearmotor, compressor, and condenser fan motor come on, lighting the Drive LED (DR) and compressor LED (C). The compressor is started through a current style relay that is pulled in by the initial high current draw of the compressor. The gearmotor start windings are also energized through a current relay. The B-E and WTR LED remain on.

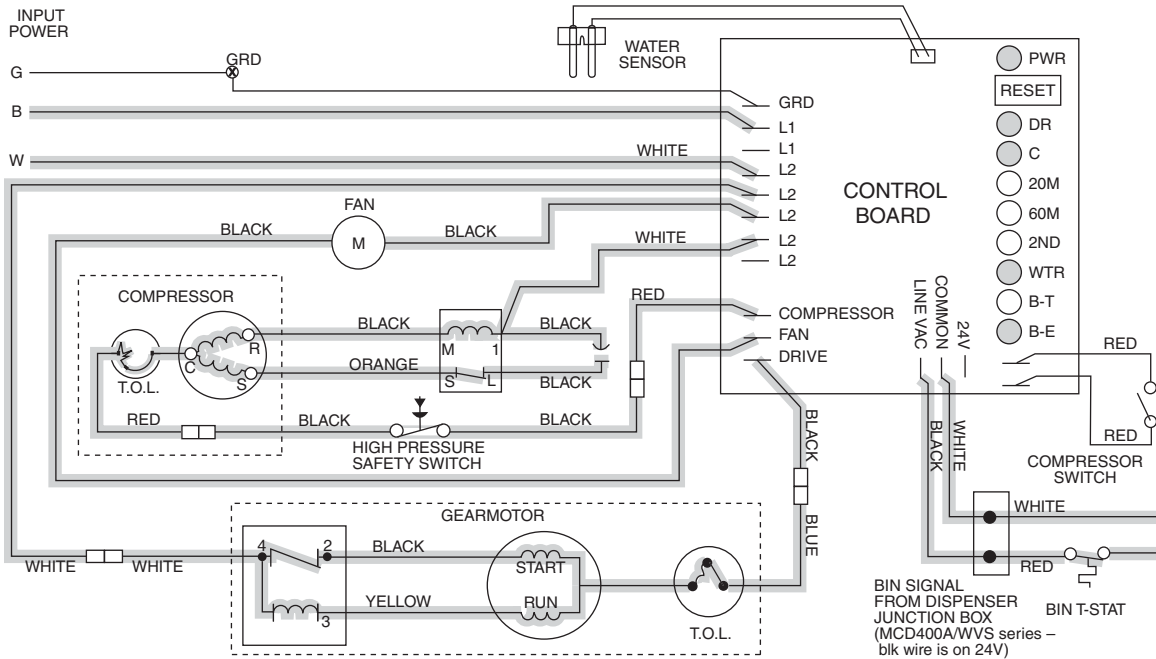

Normal operation – Stage 3

After the initial high current draw drops off, the gearmotor start relay contacts open dropping out the start winding. As the compressor comes up to normal running speed, the compressor start relay contacts open, dropping out the start winding of the compressor. The icemaker is now in a normal icemaking mode. The icemaker will produce ice until the bin level control in the ice dispenser is satisfied. The B-E, DR, C and WTR LEDs are all on.

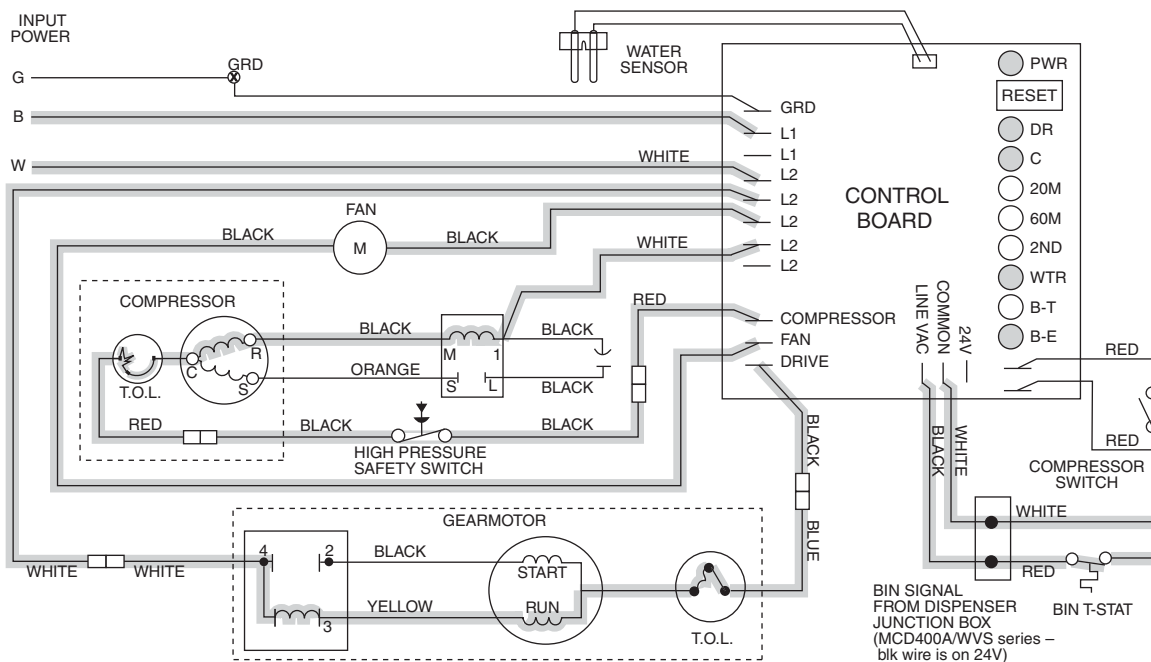

Normal operation – Stage 4

Once the ice level control opens, the B-E LED goes out. After a 10 second delay the LED (C), compressor, and fan motor go off and the B-T LED comes on. (Should the ice level control not remain open for 10 seconds, the icemaker will continue to run.) The gearmotor continues to run for 60 seconds. The purpose of this function is to drive the remaining ice out of the evaporator and to boil off any refrigerant remaining in the evaporator.

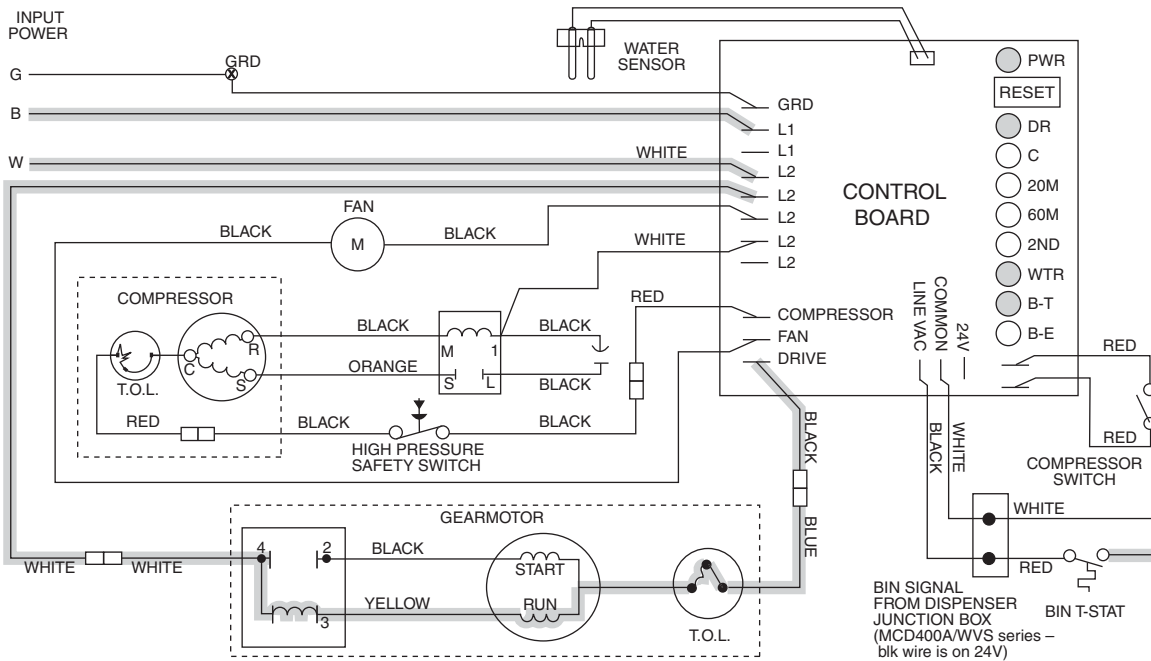

Normal operation – Stage 5

The B-T LED will remain on for 20 minutes. The icemaker will not start while the B-T LED is on. To restart the icemaker for troubleshooting purposes, depress the reset button to clear the control board.

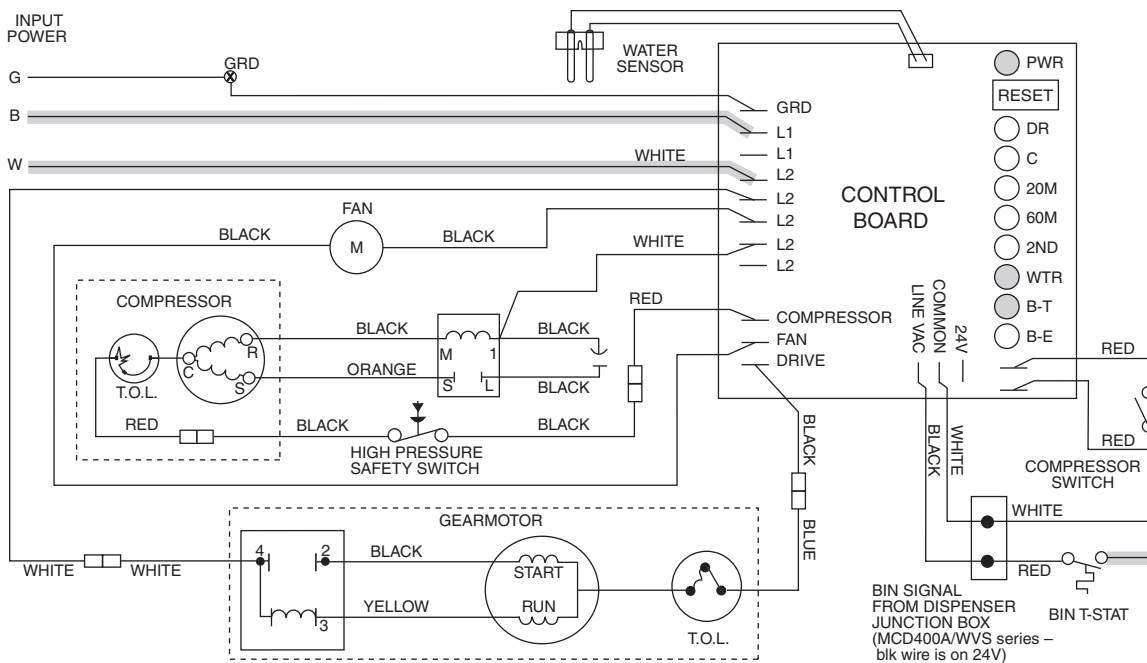

Normal operation – Stage 6

When the dwell time of 20 minutes has expired, the B-T LED goes off. The icemaker will go through the normal start-up sequence when the bin level control signals the control board for ice. The WTR LED will remain on as long as the water sensor in the float reservoir senses water.

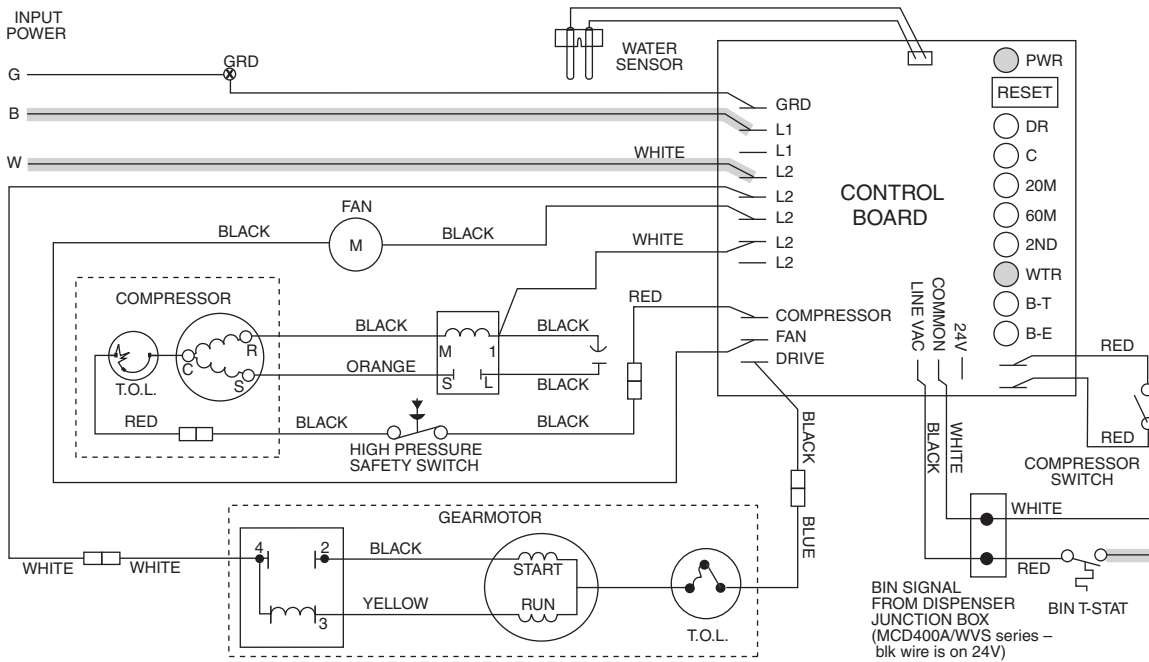

Diagnostic sequence – Stage 7

The 20 minute error LED (20M) is on indicating that the control board has sensed an over-torque condition (above 3 AMPS on the gearmotor) and shut the icemaker down. The 20M LED will remain on for 20 minutes after an over-torque condition has occurred. The icemaker will remain off as long as the 20M LED is on. When the 20M LED goes off, the control board will try to go through a normal start-up sequence. The WTR LED remains on as long as the water sensor in the float reservoir senses water.

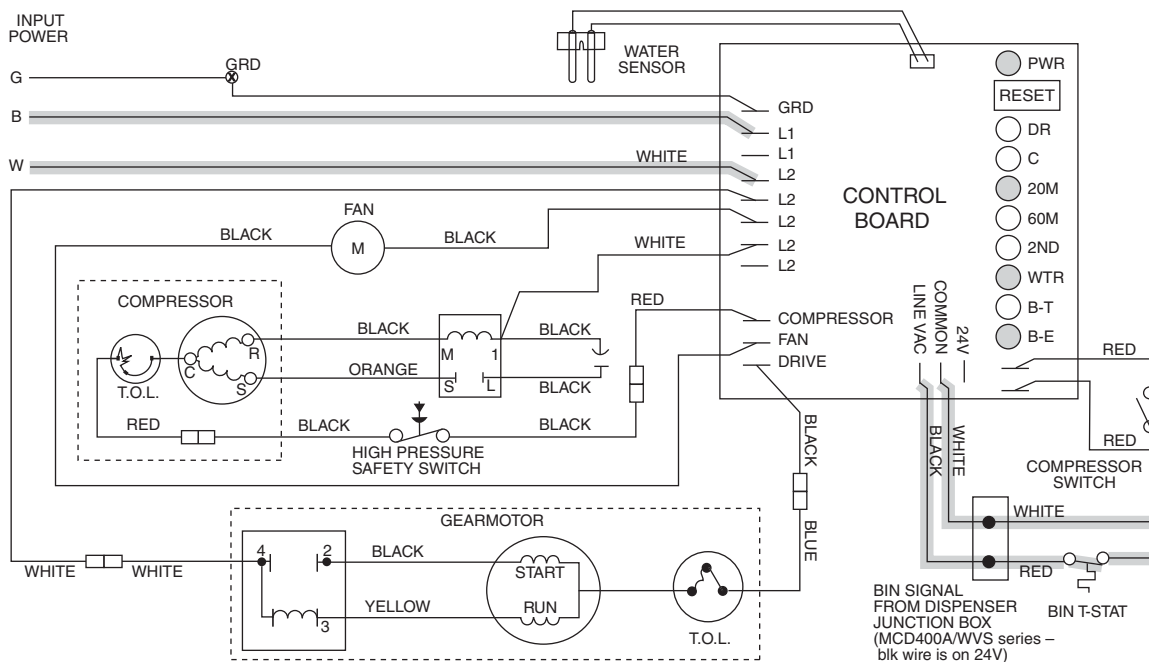

Diagnostic sequence – Stage 8

If the restart is successful the 20M LED goes off, the 60 minute timer LED (60M) comes on. The 60M LED will remain on for 60 minutes from restart. A lighted 60M LED tells the technician that the icemaker has experienced an over-torque condition. If the icemaker runs without problems for 60 minutes and no additional torque errors occur, the 60M LED will go off and the icemaker will continue normal operation.

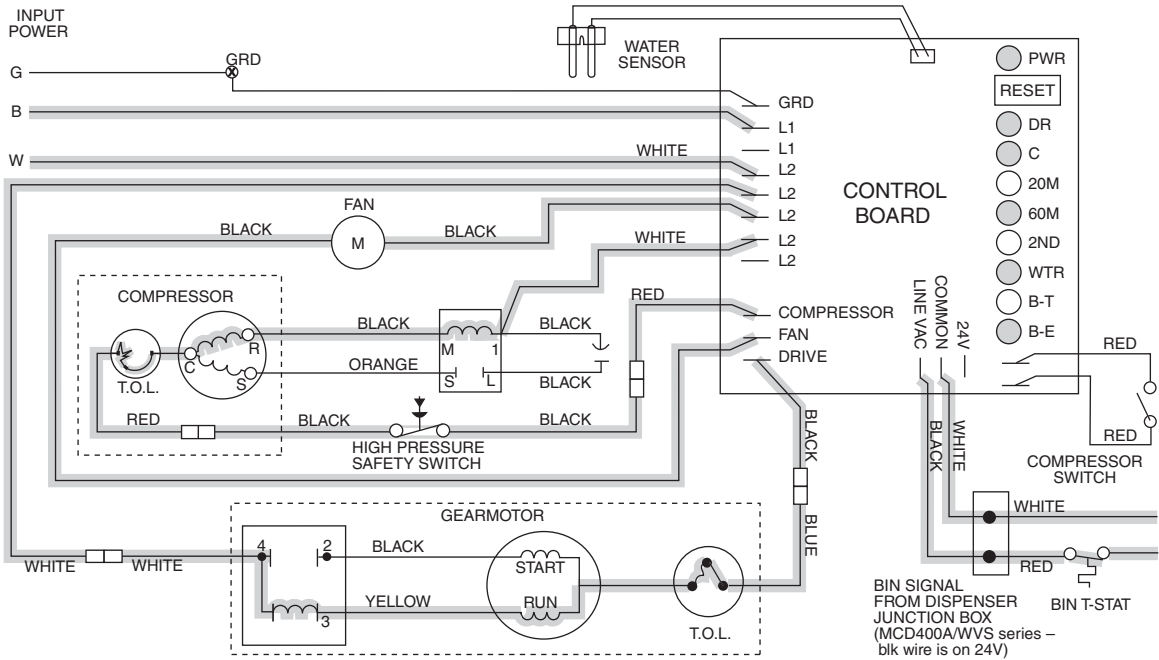

Diagnostic sequence – Stage 9

The second error (2ND) LED will come on if an over-torque condition occurs while the 60M LED is still lighted. The 2ND LED will indicate to the technician that two consecutive over-torque situations have occurred. The icemaker will shut down at this time and lock out. It will not restart unless the manual reset button is depressed.

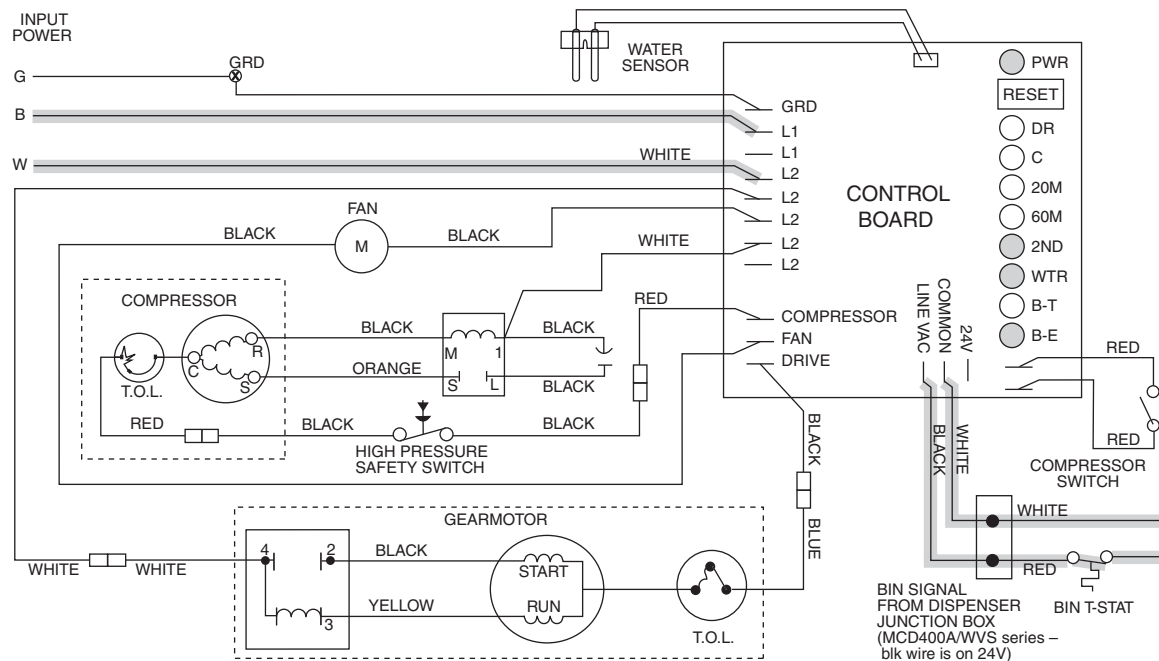

Diagnostic sequence – Stage 10

If the water level in the float reservoir drops to an unacceptable level, the WTR LED will go out, shutting the icemaker off. Also, the BT LED will come on, preventing the icemaker from restarting for twenty minutes. If water is restored, the WTR LED will come back on and flash to alert the technician that water to icemaker has been lost. The icemaker will then restart at the end of the 20 minute time delay. The flashing WTR LED can be cleared by pressing the reset button.

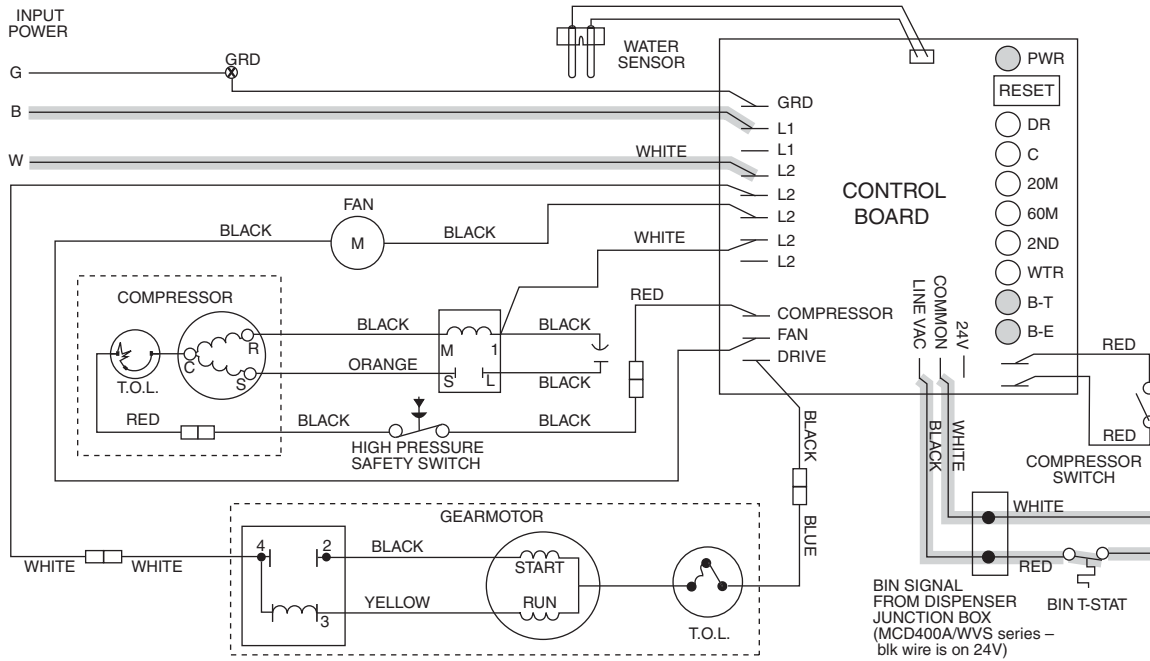

Refrigeration system (all models)

All service on refrigeration systems must be performed in accordance with all federal, state and local laws. It is the responsibility of the technician to ensure that these requirements are met. Recharging icemaker to other than factory specifications will void the warranty.

R404A icemaker charge specifications		
Model	Charge	Refrigerant type
T400A, MCD400A, MFD400A, R400A, D400A (air-cooled)	19oz (539g)	R404A
T400W, MCD400W, MFD400W, R400W , D400W (water-cooled)	9oz (255g)	R404A

Refrigerant replacement requirements

1. Non-contaminated refrigerant removed from any Follett refrigeration system can be recycled and returned to the same system after completing repairs. Recycled refrigerant must be stored in a clean, approved storage container. If additional refrigerant is required, virgin or reclaimed refrigerant that meets ARI standard 700-88 must be used.
2. In the event of system contamination (for example, a compressor burn out, refrigerant leak, presence of non-condensibles or moisture), the system must be repaired, evacuated and recharged using virgin or reclaimed refrigerant that meets ARI standard 700-88.
3. Follett Corporation does not approve of recovered refrigerants. Improper refrigeration servicing procedures will void the factory warranty.

Evacuation

Evacuate the system to a level of 500 microns. When the 500 micron level is reached, close valves and both manifold and shut down the vacuum pump. Allow the system to sit for approximately 20 minutes. During this period the system pressure should not rise. If the system pressure rises and stabilizes there is moisture in the system and further evacuation is needed. If the pressure continues to rise check the system for leaks.

Ambients	Minimum	Maximum
Air temperature ¹	50 F/10 C	100 F/37.8 C
Water temperature ²	40 F/4.4 C	90 F/32.2 C

¹Ambient air temperature is measured at the air-cooled condenser coil inlet.

²Ambient water temperature is measured in the icemaker float reservoir.

Ice capacity test

Icemaker production capacity can only be determined by weighing ice produced in a specific time period.

1. Replace all panels on icemaker.
2. Run icemaker for at least 15 minutes.
3. Weigh and record weight of container used to catch ice.
4. Catch ice for 15 or 20 minutes.
5. Weigh harvested ice and record total weight.
6. Subtract weight of container from total weight.
7. Convert fractions of pounds to decimal equivalents (ex. 6 lbs 8oz = 6.5 lbs).
8. Calculate production using following formula:

$\frac{1440 \text{ min.} \times \text{wt. of ice produced}}{\text{Total test time in minutes}} = \text{Production capacity/24 hr. period}$
--

9. Calculated amount per 24 hours should be checked against rated capacity for same ambient and water temperatures in Ice Production Tables.

Service procedures

Evaporator disassembly (Fig. 7)

1. Disconnect power to icemaker.
2. Shut off water to icemaker.
3. Drain evaporator and float tank.
4. Disconnect plastic tubing from evaporator water inlet, drain pan stub, compression nozzle tubing and reservoir overflow tubing from secured clip.
5. Disconnect ice transport tube from compression nozzle.
Note: No compression nozzle on MFD400 series flake icemakers.
6. Loosen nut and remove upper vee band coupling from top of evaporator.
7. Lift top bearing assembly straight up with a slight rotating motion and remove.
8. Remove ice compression loop located at top of auger.
9. Lift auger straight up and out of evaporator.
10. Remove nut and lower vee band coupling from bottom of evaporator.
11. Lift evaporator to clear bottom bearing assembly.
12. Loosen hex head bolt in side of mounting base with 5/16 wrench and lift lower bearing assembly.
13. Remove condensate shield.
14. Remove 4 Allen head machine screws holding mounting base to gearbox.
15. If replacing evaporator, remove compression nozzle from evaporator port.

Evaporator reassembly (Fig. 7)

1. Clean gearmotor boss, output shaft and shaft well.
2. Install drain pan and evaporator mounting base.
3. Fill gearmotor shaft well with food-grade grease (Fig. 8).
4. Install condensate shield and seat against gearmotor boss.
5. Install mounting base O ring in groove in evaporator mounting base.
6. Lower bottom bearing assembly into evaporator mounting base.
7. While maintaining a downward pressure on bottom bearing assembly, tighten hex head bolt with a 5/16 wrench.
8. Position evaporator over lower bearing assembly and align grooves with pins in bearing assembly.
9. Install vee band clamp and nut and tighten to 70 in/lb.
10. Place auger in center of evaporator and rotate to mate with drive pin.
11. Install ice compression loop, orienting loop as shown in Fig. 7.
Note: No compression nozzle on MFD400 series flake icemakers.
12. Install upper bearing and seal assembly, rotating bearing to slip pin into auger slot.
13. Install upper vee band clamp and nut and tighten to 70 in/lb.
14. If evaporator was replaced, reinstall compression nozzle.

Gearmotor replacement (Fig. 8)

1. Disassemble evaporator as described above.
2. Disconnect the wire connectors.
3. Remove 4 screws holding gearmotor mounting plate to base of icemaker and lift gearbox and motor clear of icemaker (Fig. 8.1).
4. Remove machine screws holding mounting plate to motor (Fig. 8.2).
5. Install new motor in reverse order.

Fig. 7

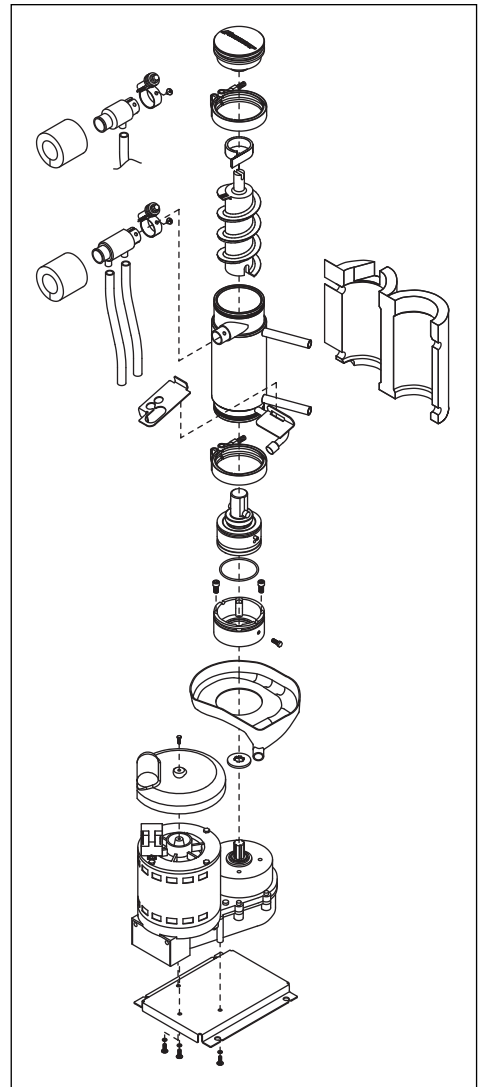
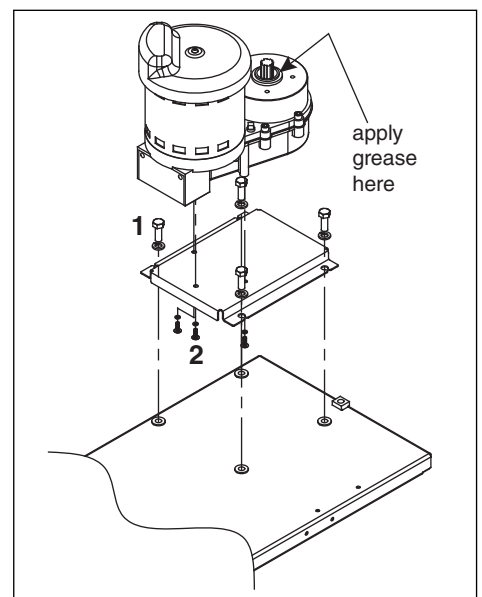

Fig. 8



Troubleshooting chart

Flashing water LED at any time indicates that water signal to board had been lost for more than one second.

Ten-second delay: There is a 10 second delay in reaction to loss of water (WTR) or bin (B-E) signals. If signals are not lost for more than 10 seconds, no reaction will occur.

Problem	Indicators/possible cause	Corrective action
<p>1. Icemaker will not run.</p> <p>System status: compressor, gearmotor, and fan motor inoperative.</p>	<ol style="list-style-type: none"> 1. No power to unit. 2. Open bin level control. 3. Water OK LED (WTR) not on. 4. 20M or 2ND LED is on indicating that first or second torque error has occurred. 5. Gearmotor locked up (immediate torque error indicated by LEDs when board is reset). 6. Open coil on gearmotor start relay causing an immediate torque error. 	<ol style="list-style-type: none"> 1. Check that unit is plugged in, circuit breakers are on. 2. Adjust or replace ice level control. 3. Check reservoir for water, restore water to unit. 4. See Problem #6. 5. Repair or replace gear motor. 6. Replace gearmotor start relay.
<p>2. Compressor will not run.</p> <p>System status: gearmotor and fan motor run.</p>	<ol style="list-style-type: none"> 1. Condenser coil plugged causing open overload or high pressure cut-out. 2. Defective starting capacitor. 3. Defective starting relay. 4. Open motor winding. 5. No power output from compressor output terminal on control board. 	<ol style="list-style-type: none"> 1. Clean condenser coil and replace overload if necessary. 2. Replace start capacitor. 3. Replace relay. 4. Check winding resistance and replace compressor if necessary. 5. Check terminal connection and replace control board if necessary.
<p>3. Unit cycles intermittently.</p> <p>System status: compressor, gear motor, and fan motor cycle.</p>	<ol style="list-style-type: none"> 1. Float reservoir running dry, sensing probe signalling for system to shut down. 	<ol style="list-style-type: none"> 1. Check water supply to float and float operation. PC board will have flashing WTR LED.
<p>4. Low ice production. Poor quality ice.</p>	<ol style="list-style-type: none"> 1. Dirty condenser coil. 2. Restricted air flow to condenser coil. 3. Mineral coated evaporator. 4. High ambient water supply and/or air temperature. 5. Improper exhaust air provisions. 6. Faulty expansion valve. 7. Low refrigerant charge. 8. Superheat incorrect. 9. Inefficient compressor. 	<ol style="list-style-type: none"> 1. Clean condenser. 2. Remove obstruction. 3. Clean evaporator. 4. Precool water and/or install air duct per Follett installation manual. 5. Provide proper exhaust air provisions per Follett installation manual. 6. Replace expansion valve. 7. Check for leaks; repair, evacuate, and weigh in correct charge. 8. Check that TEV sensing bulb is securely clamped in place and not damaged; check that insulated bulb cover is in place. Replace TEV if necessary. 9. Replace compressor.
<p>5. Water leaks from bottom of evaporator.</p>	<ol style="list-style-type: none"> 1. O ring seal broken. 	<ol style="list-style-type: none"> 1. Replace O ring.

Troubleshooting

Problem	Indicators/possible cause	Corrective action
<p>6. Icemaker runs for short period of time and shuts down on torque error.</p> <p>System status: 20M or 2nd LED are lit.</p>	<ol style="list-style-type: none"> 1. Kink in ice transport tube. 2. Bin level control remains in closed position. 3. Ice transport tube ruptured internally. 4. Worn evaporator bearings. 5. Faulty gearmotor start relay. Icemaker torques out within 5 seconds of start-up. 6. Torque-out occurs when storage bin fills to capacity. 	<ol style="list-style-type: none"> 1. Eliminate kink and check that tube routing complies with Follett icemaker installation manual. 2. Adjust or replace control. 3. Replace complete run of ice transport tube. 4. Inspect bearings for roughness or binding and replace if necessary. 5. Replace gearmotor start relay. 6. Ensure that ice contacts bin thermostat before backing ice up in transport tube. Reference dispenser manual for proper thermostat and ice tube mounting.
<p>7. Evaporator is iced up on the outside. No ice production.</p> <p>System status: compressor, gearmotor and fan motor running.</p>	<ol style="list-style-type: none"> 1. Gearmotor running but no output rotation. 2. Float reservoir empty. 3. Air bubble in water supply line. Water in reservoir but not in evaporator. 	<ol style="list-style-type: none"> 1. Check for broken gearmotor output shaft or damaged gearbox. 2. Check for defective water sensor (water OK (WTR) LED remains on even when float empty or probe removed from water). 3. Purge air from line.
<p>8. Compressor cycles intermittently.</p> <p>System status: gearmotor and fan motor run.</p>	<ol style="list-style-type: none"> 1. Compressor start relay in wrong position. 2. High pressure cutout open due to high head pressure. 3. Clogged or dirty condenser coil. 4. Improper ventilation. 5. Defective compressor. 	<ol style="list-style-type: none"> 1. Position relay with arrow or word "top" facing up. 2a. Check supply and temperature of water to w/c condenser. 2b. Check discharge pressure and adjust water regulator value. 3. Clean condenser coil. 4. Provide inlet and exhaust air provisions per Follett icemaker installation manual. 5. Replace compressor.
<p>9. Unit runs but not making ice.</p> <p>System status: compressor, gearmotor and fan motor running.</p>	<ol style="list-style-type: none"> 1. Clogged or dirty condenser coil. 2. Compressor not pumping. 3. Low refrigerant charge. 	<ol style="list-style-type: none"> 1. Clean condenser coil. 2. Replace compressor. 3. Check for leaks; repair, evacuate, and weigh in correct charge.
<p>10. Compressor and fan motor will not run. Gearmotor runs.</p>	<ol style="list-style-type: none"> 1. Compressor switch in OFF position. 2. No output on compressor and fan motor terminals on control board. 3. Failed fan motor causes high pressure cut-out to open. 	<ol style="list-style-type: none"> 1. Turn compressor switch on. 2. Replace control board. 3. Replace fan motor.
<p>11. Intermittent noises from evaporator.</p>	<ol style="list-style-type: none"> 1. Mineral build-up on evaporator surface. 	<ol style="list-style-type: none"> 1. Clean evaporator with liquid IM cleaner.

Replacement parts

Order parts online
www.follettice.com

Evaporator

Part #	Description	Reference #
502735	Coupling, vee band, includes nut	1
502736	Bearing assembly, top	2
502110	Loop, ice compression, beveled (all icemakers except MFD400 series –see flaker-specific components below)	3
502737	Auger (all icemakers except MFD400A/W – see flaker specific components below)	4
502725	Evaporator (includes insulation jacket, 502740)	5
500496	O ring, bearing housing	6
502738	Bearing assembly, bottom (includes O rings and condensate shield)	7
501063	O ring, mounting base	8
500744	Shield, condensate	9
501080	Screw, Allen 1/4 20 x 1/2 (set of 4)	10
502733	Mounting base, evap. (includes 501063)	11
502227	Bolt, mounting base	12
502730	Gearbox & motor assembly	13
502729	Mounting base, gearbox	Not shown
502220	Compression nozzle, with double drain (no nozzle in MFD400 series)	14
502221	Compression nozzle, with single drain (no nozzle in MFD400 series)	15
502727	Drain pan, evaporator	16
502226	Clamp, compression nozzle and screw	17
500680	Tubing, compression nozzle drain(s) (sold by foot)	18
501111	Grease, Chevron SRI-2, 14oz	Not shown
502739	Bracket, drain hose	19
502740	Insulation jacket, evaporator	20
502742	Relay, start, gearmotor	21
502744	Drip cover, gearmotor	22
502743	Evaporator & gearmotor assembly	Not shown
502775	Oil, gearmotor (1 pint)	Not shown

Flaker-specific components

Part #	Description	Reference #
00124123	Auger (with paddle)	3
00124115	Loop, compression, notched	4

Evaporator

Order parts online
www.follettice.com

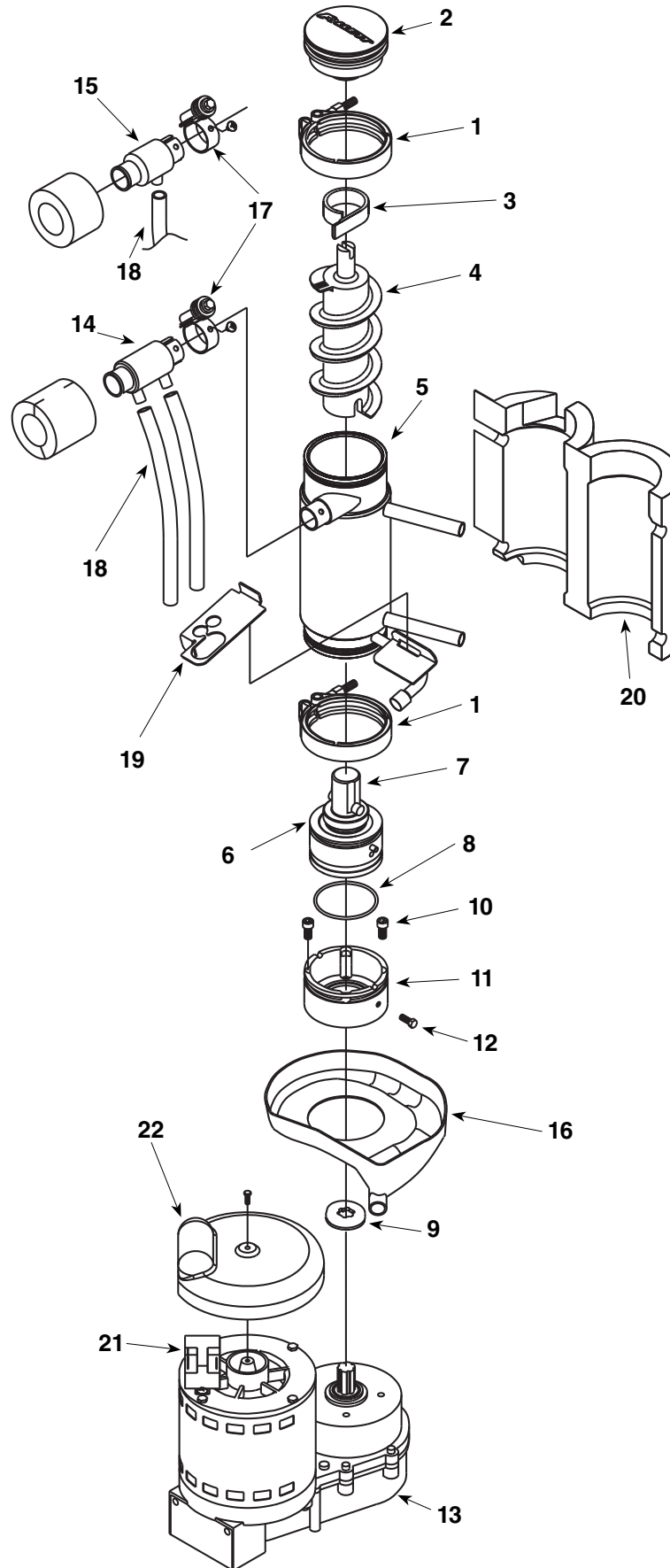

Air-cooled icemakers

Order parts online
www.follettice.com

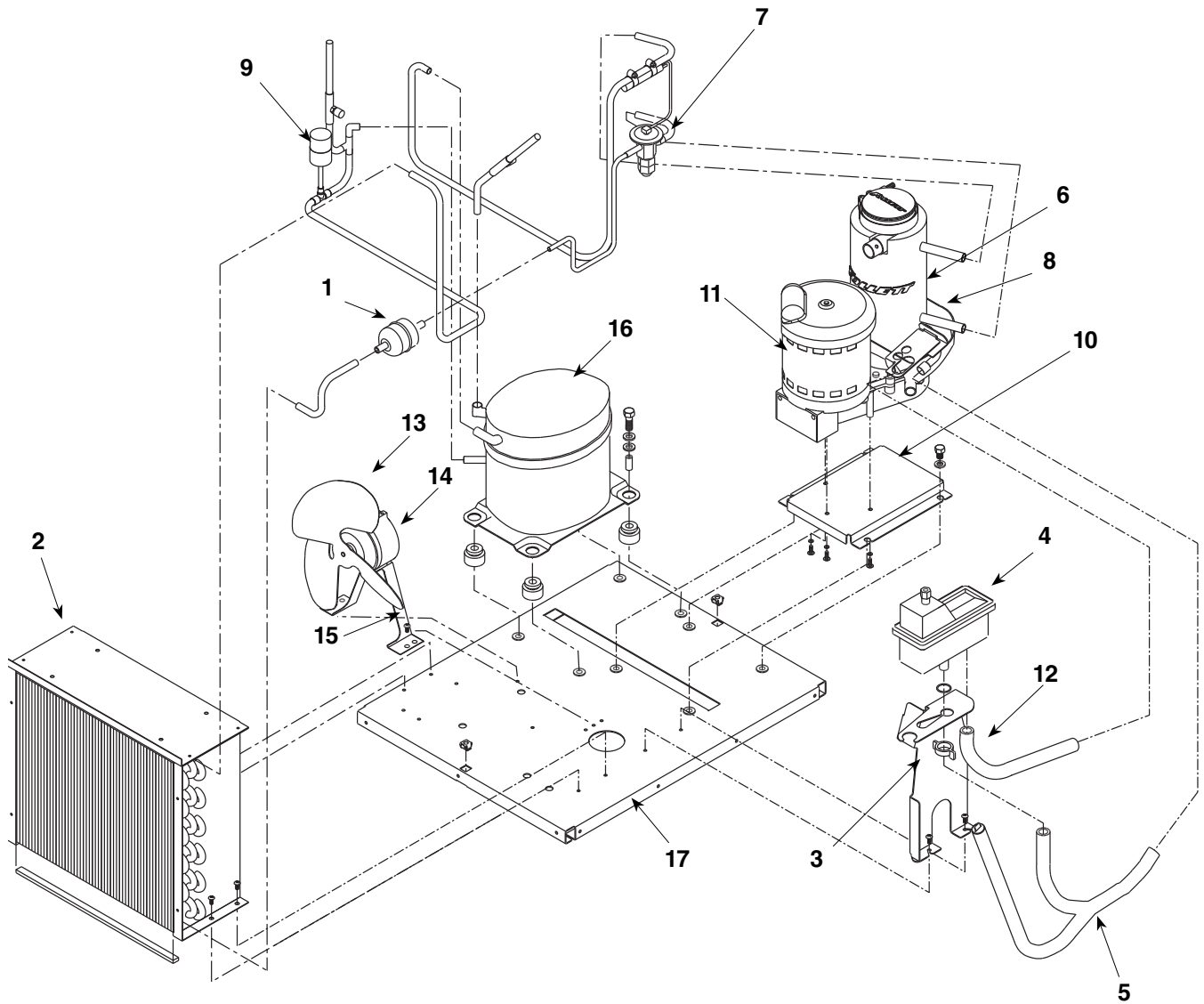

Air-cooled icemakers

Order parts online
www.follettice.com

Part #	Description	Reference #
502724	Drier	1
501187	Condenser coil, A/C	2
502116	Water sensor	Not shown
501986	Reservoir mounting bracket	3
500504	Float valve & reservoir	4
00141440	Drain kit, evaporator	5
	Evaporator (see page 32 and 33 for complete breakdown)	6
502079	Tubing, polypropylene, reservoir supply (sold by foot)	Not shown
502078	Fitting, plastic, float valve (includes sleeve & stem)	Not shown
502220	Compression nozzle, with double drain	Not shown
502221	Compression nozzle, with single drain	Not shown
502726	Valve, expansion, thermal	7
502727	Drain pan, evaporator	8
502732	High pressure cutout	9
501966	Tubing, evaporator drain, 3/4" (19mm) ID x 1" (26mm) OD (sold by the foot)	Not shown
502729	Mounting bracket, gearbox	10
502730	Gearbox & motor assembly, 115V, 60Hz	11
501191	Tubing, plastic, food grade, 1/2" (13mm) ID (sold by foot)	12
500474	Fan blade	13
500672	Motor, fan, 115V, 60Hz	14
501188	Bracket, fan motor	15
502782	Overload, compressor, 115V, 60Hz	Not shown
502731	Compressor, 115V, 60Hz	16
502728	Base – L400A	17
500376	Strainer, water, threaded connections	Not shown
502920	Strainer, push-in connections	Not shown
501820	Shroud, condenser coil	Not shown
502734	Water inlet & drain assembly, brass	Not shown
502924	Water inlet fitting, plastic	Not shown
502925	Water inlet elbow, plastic	Not shown
00109728	Drain fitting, plastic	Not shown
502830	Jacket, insulation, TXV	Not shown
502698	Bracket, ice tube entry	Not shown

Water-cooled icemakers before serial number C57245

Order parts online
www.follettice.com

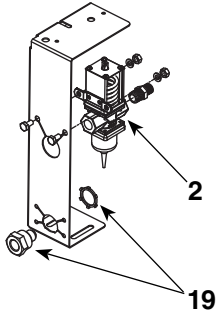
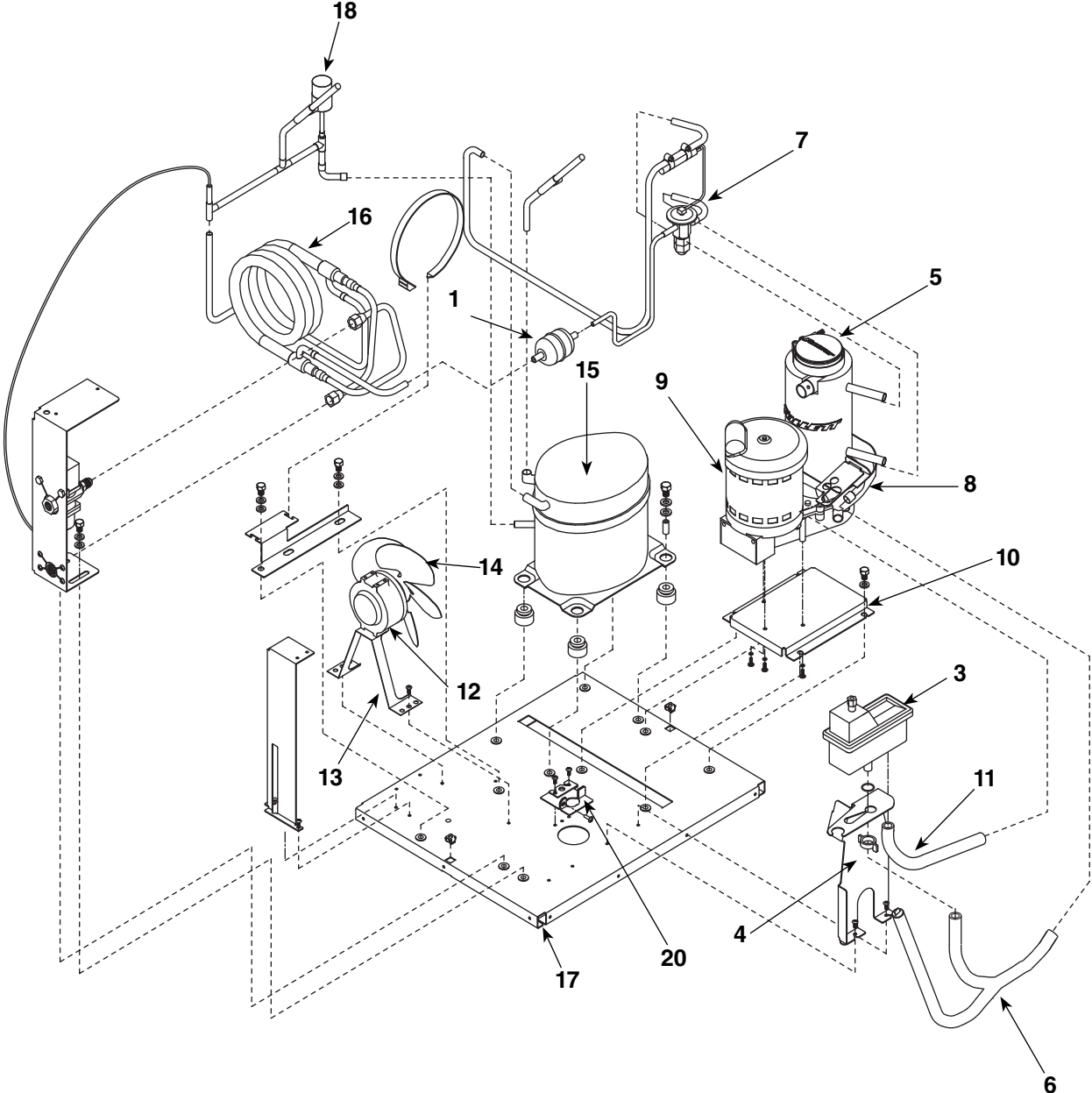

Water-cooled icemakers before serial number C57245**Order parts online
www.follettice.com**

Part #	Description	Reference #
502724	Drier	1
500537	Valve, water regulating (includes 501810)	2
501810	Iso-washer (for water regulating valve)	Not shown
502116	Water sensor	Not shown
500504	Float valve & reservoir	3
501986	Reservoir mounting bracket	4
502079	Tubing, polypropylene, reservoir supply (sold by foot)	Not shown
502078	Fitting, plastic, float valve (includes sleeve & stem)	Not shown
502220	Compression nozzle, with double drain	Not shown
502221	Compression nozzle, with single drain	Not shown
	Evaporator (see page 32 and 33 for complete breakdown)	5
00141440	Drain kit, evaporator	6
502954	Drain kit, evaporator, water-cooled freestanding units	6
502726	Valve, expansion, thermal	7
502727	Drain pan, evaporator	8
501966	Tubing, evaporator drain, 3/4" (19mm) ID x 1" (26mm) OD (sold by foot)	Not shown
502730	Gearbox & motor assembly, 115V, 60Hz	9
502729	Mounting bracket, gearbox	10
501191	Tubing, plastic, food grade, 1/2" (13mm) ID (sold by foot)	11
500672	Motor, fan, 115V, 60Hz	12
501188	Bracket, fan motor	13
500790	Fan blade	14
502782	Overload compressor, 115V, 60Hz	Not shown
502731	Compressor, 115V, 60Hz	15
00111898	Coil, condenser	16
502741	Base, L400W	17
500376	Strainer, water, threaded connections	Not shown
502920	Strainer, push-in connections	Not shown
502734	Water inlet and drain assembly, brass	Not shown
502924	Water inlet fitting, plastic	Not shown
502925	Water inlet elbow, plastic	Not shown
00109728	Drain fitting, plastic	Not shown
502348	Assembly, drain, single fitting	Not shown
502732	High pressure cutout	18
502830	Jacket, insulation, TXV	Not shown
00143941	Fitting, condenser drain	19
502698	Bracket, ice tube entry	20

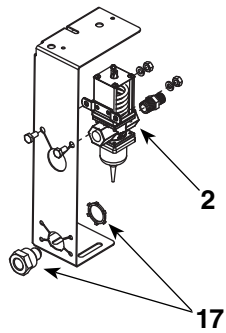
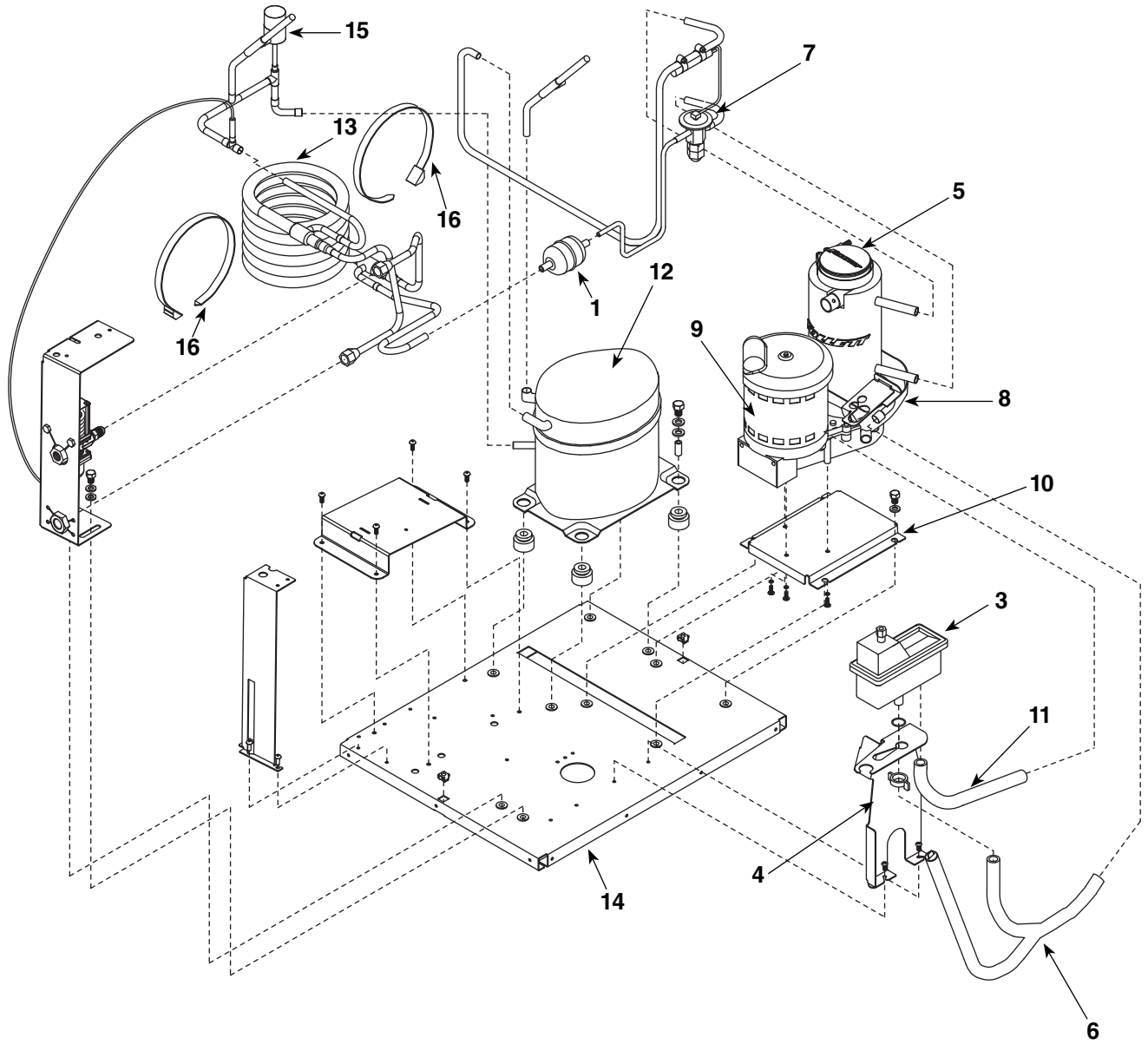

Water-cooled icemakers after serial number C57244**Order parts online**
www.follettice.com

Part #	Description	Reference #
502724	Drier	1
500537	Valve, water regulating (includes 501810)	2
501810	Iso-washer (for water regulating valve)	Not shown
502116	Water sensor	Not shown
500504	Float valve & reservoir	3
501986	Reservoir mounting bracket	4
502079	Tubing, polypropylene, reservoir supply (sold by foot)	Not shown
502078	Fitting, plastic, float valve (includes sleeve & stem)	Not shown
502220	Compression nozzle, with double drain	Not shown
502221	Compression nozzle, with single drain	Not shown
	Evaporator (see page 32 and 33 for complete breakdown)	5
00141440	Drain kit, evaporator	6
502954	Drain kit, evaporator, water-cooled freestanding units	6
502726	Valve, expansion, thermal	7
502727	Drain pan, evaporator	8
501966	Tubing, evaporator drain, 3/4" (19mm) ID x 1" (26mm) OD (sold by foot)	Not shown
502730	Gearbox & motor assembly, 115V, 60Hz	9
502729	Mounting bracket, gearbox	10
501191	Tubing, plastic, food grade, 1/2" (13mm) ID (sold by foot)	11
502782	Overload compressor, 115V, 60Hz	Not shown
502731	Compressor, 115V, 60Hz	12
00195933	Coil, condenser	13
502741	Base, L400W	14
500376	Strainer, water, threaded connections	Not shown
502920	Strainer, push-in connections	Not shown
502734	Water inlet and drain assembly, brass	Not shown
502924	Water inlet fitting, plastic	Not shown
502925	Water inlet elbow, plastic	Not shown
00109728	Drain fitting, plastic	Not shown
502348	Assembly, drain, single fitting	Not shown
502732	High pressure cutout	15
502830	Jacket, insulation, TXV	Not shown
204584	Ty-rap (2 required)	16
00143941	Fitting, condenser drain	17
502698	Bracket, ice tube entry	Not shown

Electrical components

Order parts online
www.follettice.com

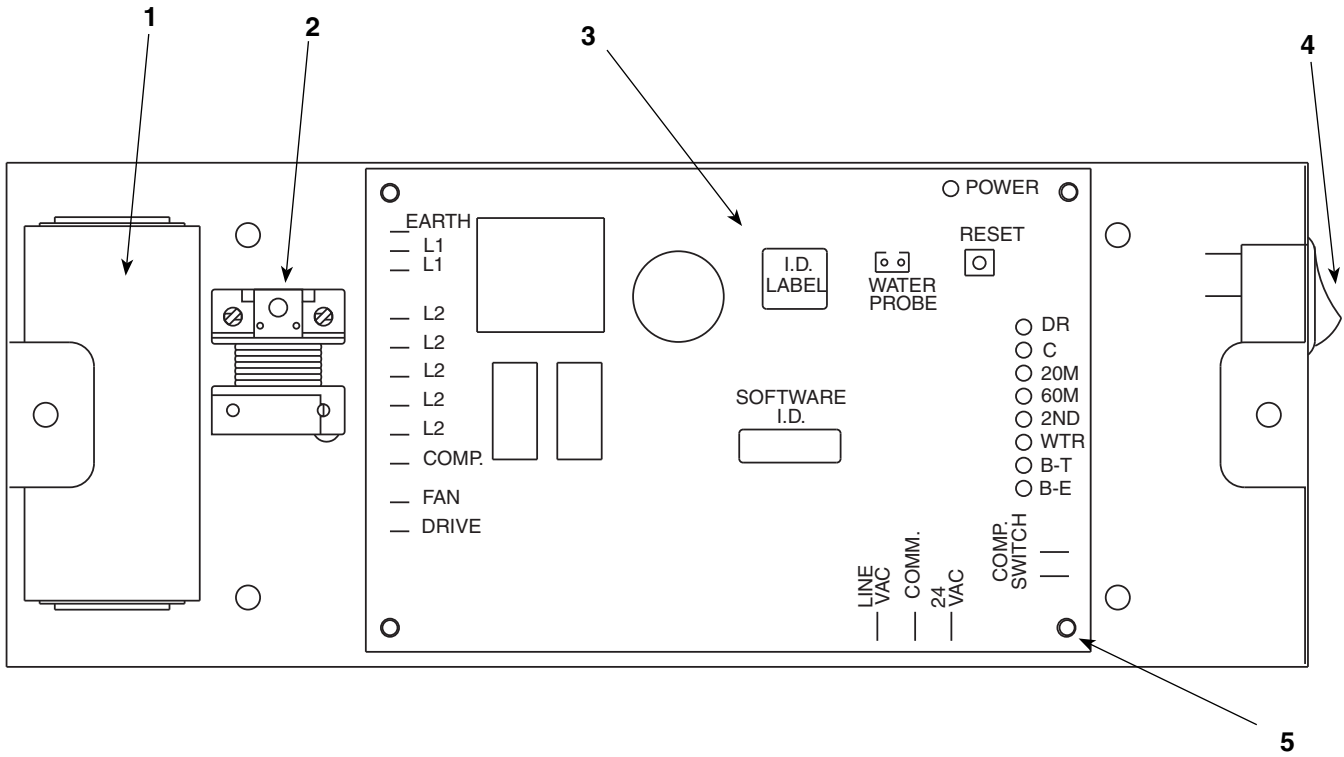

Part #	Description	Reference #
502780	Capacitor, start, compressor, 115V, 60Hz	1
501588	Relay start, compressor, 115V, 60Hz	2
502331	Board, control circuit, 115V, 60Hz	3
502116	Water sensor	Not shown
502392	Switch, on/off, compressor	4
500514	Bin thermostat (MCD400A/WBT, MCD400A/WHT, MFD400A/WBT and MFD400A/WHT only)	Not shown
501959	Board, stand off control (4 required)	5

Water filter kits and cartridges

00130229	Follett QC4-FL4S water filter system (includes FL4S primary cartridge and head, coarse pre-filter and head, pressure gauge, flushing valve; assembled and installed on mounting bracket)
00130245	Follett FL4S primary replacement cartridge
00130211	Everpure coarse pre-filter cartridge

Ice machine cleaner

00132001	SafeCLEAN environmentally-friendly cleaner, carton of 24 x 7 oz packets
----------	---

Miscellaneous

501860	Condensate pump
501781	Regulator, water pressure (25 psi)
502775	Oil, gearmotor, 1 pint
501111	Grease, Chevron, SRI-2, 14 oz tube
500377	Clamp, ice tube
501921	Grommet, ice tube
502783	Duct – 2" (51mm)
502781	Gasket, air duct
501425	Grille
501986	Bracket, float mounting
501759	Cord and plug (female), dispenser bin signal (F1105A/W)
501858	Cord and plug (female), dispenser power (all 25, 50, 110 series dispensers)
501786	Cord and plug (female), dispenser bin signal (all 25 and 50 series top mount and freestanding dispensers)
501702	Control board adapter (R404A to R12)
502051	Cord and twist-lock plug (male), icemaker bin signal
502052	Cord and twist-lock plug (male), icemaker power
502333	Plug, twist-lock, two lead, male
502334	Plug, twist-lock, two lead, female
502235	Plug, twist-lock, three lead, male
502336	Plug, twist-lock, three lead, female
502794	Panel, right hand, louvered, R400A, MCD400A/W
502795	Cover, top, R400A/W, MCD400A/W
502796	Panel, front utility, R400A, MCD400A
502797	Panel, top front, R400A, MCD400A
502798	Panel, left hand & rear, R400A/W, MCD400A/W
502799	Panel, front, R400W, MCD400W
502800	Filler, base, R400A/W, MCD400A/W
502801	Condenser, L400W
502802	Power cord, R400, MCD400
502803	Bin signal cord, R400, MCD400
502874	Grille, condenser, T400A and MCD400AHT
502875	Filter, air, T400A and MCD400AHT
00918045	Assembly, front cover

Replacement icemaker ordering matrix

Order parts online
www.follettice.com

Dispenser models	Replacement icemaker model
Dispensers with top mounted icemakers	
50CT400A & 50HT400A	D400A
50HT400W & 50HT400W	D400W
25CT 400A & 25HT400A	D400A
25CT400W & 25HT400W	D400W
110CT400A	D400A
110CT400W	D400W
Dispensers with remote icemakers	
25CR400A & 25HR400A	R400A
25CR400W & 25HR400W	R400W
50CR400A & 50HR400A	R400A
50CR400W & 50HR400W	R400W
110CR400A	R400A
110CR400W	R400W
All U150/VU155 series with air-cooled icemakers	MCD400A
All U150/VU155 series with water-cooled icemakers	MCD400W
All VU300 series with air-cooled icemakers	MCD400A
All VU300 series with water-cooled icemakers	MCD400W
Dispenser models	
Replacement icemaker model	
Freestanding dispensers with icemakers in the base	
25FB400A	D400A
25FB400W	D400W
50FB400A	D400A
50FB400W	D400W
110FB400A	D400A
110FB400W	D400W
Nugget icemaker on top of bin	
MCD400ABT	MCD400ABT
MCD400WBT	MCD400WBT
Flake icemaker on top of bin	
MFD400ABT	MFD400ABT
MFD400WBT	MFD400WBT

Harmony, SafeCLEAN, Satellite-fill, Symphony and Vision are trademarks of Follett Corporation.



801 Church Lane • Easton, PA 18040, USA
Toll free (877) 612-5086 • +1 (610) 252-7301
www.follettice.com



208600R17
01/11