

REF5-BB – For freestanding use or installation below standard 36" (915 mm) high counter. 4.2 cu ft (119 L) capacity, stores up to (50) 450 ml bags.

From the leader in medical-grade undercounter refrigerators, high performance, compact blood bank refrigerator with two stainless drawers. Temperature surveillance module includes audible/visual alarm, 7-day chart recorder and digital product temperature display. Perfect for smaller blood storage needs where space is limited.



*All-in-one temperature surveillance module
(standard with box of 60 7-day charts)*

Outstanding temperature performance meets demanding requirements for blood storage

- Meets AABB, ARC and FDA standards for blood storage at 4 C
- Powerful refrigeration system with heavy-duty 1/4 hp compressor, forced air cooling and microprocessor-based controller
- Adjustable set point is factory preset to +3.5 C,
- Maintains +/-1 C cabinet temperature
- Quick pull down and rapid recovery following frequent or extended door openings
- No defrost cycle needed

Superior drawer system delivers easy, trouble-free access

- Two full extension stainless drawers store up to (50) 450 ml bags
- Shielded stainless ball bearing rollers and stainless tracks eliminate binding and uneven wear of other systems
- Drawers and slides lift out without tools for easy cleaning
- Track/drawer interface minimizes risk of catching tubing in slides

All-in-one temperature surveillance module provides security for blood supplies

- Audible and/or visual alarm with user-selectable high and low setpoints
- Chart recorder with easy-to-read 6" (153 mm), 7-day chart
- Digital product temperature display
- Dry contacts to connect to remote alarm system
- LED power status indicator and operation buttons
- 15 foot probe lead with immersible stainless tip
- 6 foot power cord and AC adapter
- Battery backup for continuous monitoring during power failure
- Surface or wall mount ready

Quality construction and superior design details

- Completely front-breathing – requires no top, side or back clearance
- Durable, corrosion-resistant stainless interior and exterior
- Field-reversible door with full magnetic gasket
- Heavy-duty edgemount hinges and positive locking handle
- Front-mounted product simulation bottle
- Adjustable, leveling legs with easy-gliding nylon feet

Options and accessories

- Factory-installed keypad lock
- Replacement charts (item# 00162099)
- Replacement pens (item# 00162081)
- Stacking kit (item# 00926618)
- Pedestal stand (item# 00931154)
- Temperature surveillance module deduct

JOB: _____

ITEM: _____

Front View

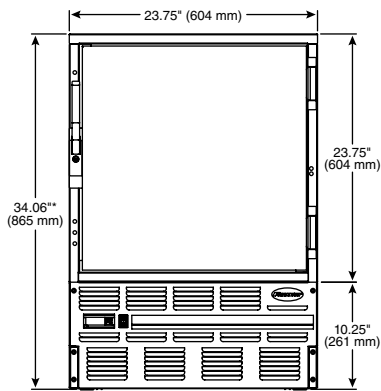

* Height includes leveling legs

Side View

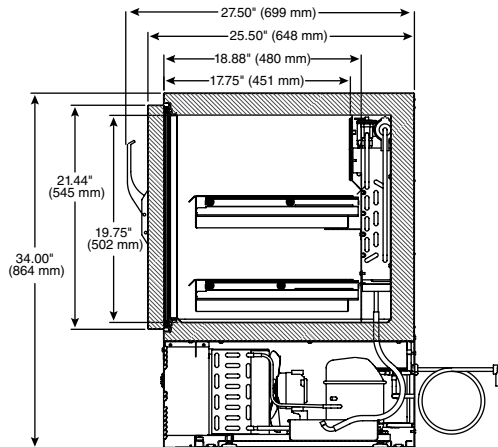

Back View

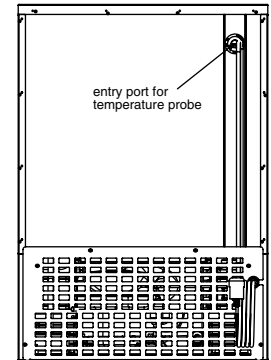

Top View

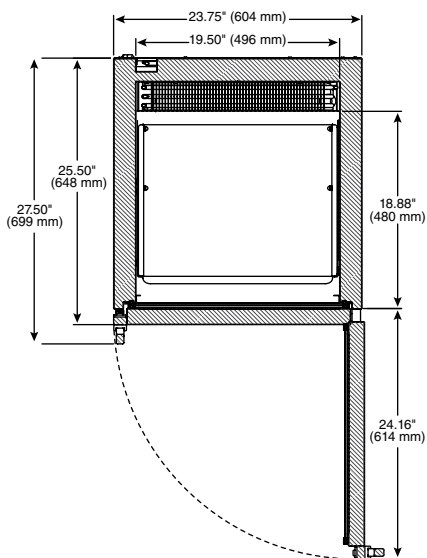

Handle Detail

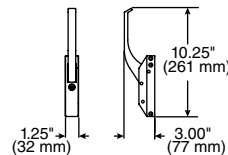
Plug Detail
NEMA 5-15

Refrigerant R404A, 10 oz

Max. heat rejection 720 BTU/hr

Electrical

115 V, 60 Hz, 1 ph, 8.0 FLA, maximum fuse – 15 amps. NEMA 5-15 hospital grade cord and plug.

Drawer dimensions

Inside dimensions 18" (457 mm) wide x 3" (76 mm) high x 14.5" (368 mm) deep

Temperature surveillance module

Overall dimensions 7.5" (191 mm) wide x 7.5" (191 mm) high x 3.55" (90 mm) deep

Approximate shipping weight 205 lbs (93 kg)

Specifications Follett® model REF5-BB, blood bank refrigerator for freestanding or undercounter use. 4.2 cu ft (119 L) capacity. Two full extension stainless drawers store up to (50) 450 ml bags. Environmentally friendly R404A refrigeration system to include heavy-duty 1/4 HP compressor, forced air cooling and microprocessor-based controller. Refrigerator to be equipped with separate temperature surveillance module, which includes audible/visual alarm, 7-day chart recorder and digital product temperature display. Refrigerator door to be field-reversible and equipped with replaceable gasket and chrome-plated handle with cylinder lock. Refrigerator interior and exterior to be stainless steel. High-density, non-CFC foam insulation. Hospital-grade cord and plug provided. Refrigerator to be UL and cUL listed.

Follett is a registered trademark of Follett Corporation, registered in the US.
Follett reserves the right to change specifications at any time without obligation. Certifications may vary depending on country of origin.