

Countertop with integral air-cooled icemaker

12CI400A-LI – 115 V, 60 Hz, lever dispensing

12CI400A-SI – 115 V, 60 Hz, SensorSAFE™ infrared dispensing



Symphony™

12CI400A-SI
(countertop with SensorSAFE™ "SI" option)

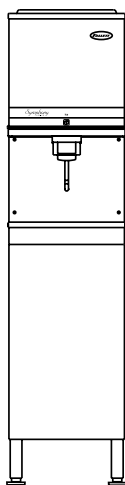

Countertop model shown
with base stand*

* See form# 2145 for specifications on base stand accessory.

Countertop ice dispensers with integral air-cooled icemaker. Produces approximately 400 lbs (181 kg) of Chewblet compressed nugget ice in a 24-hour period. Storage capacity of 12 lbs (5.4 kg). Stainless steel exterior standard.

Attractive, space-saving design

- Narrow 16" (407 mm) width and 22" (559 mm) depth fits on standard counters without overhang
- Base cabinet available for freestanding applications
- High-quality stainless exterior with plastic trim
- Attractive, modern styling

Improved sanitation and safety

- Integral icemaker with hands-free dispensing replaces icemakers with open bins
- Eliminates risk of cross-contamination from manual scooping

SensorSAFE dispensing option offers even more sanitation and convenience

- Infrared sensing eliminates container to dispenser contact, further reducing chance of cross-contamination
- Easy, one-hand filling of containers
- Bright graphics direct users to actuation zone
- Not recommended for use with clear containers or for applications in direct sunlight

Chewblet ice

- Soft, chewable compressed nugget ice
- Consumer-preferred over cubes

Easy installation

- All one unit, no assembly required
- Cord and hospital-grade plug provided

Environmentally friendly Maestro icemaker

- Stainless steel evaporator and auger
- 400 lb (181 kg) per day icemaker uses environmentally friendly CFC-free refrigerant
- Energy-efficient; no costly defrost cycles or high amounts of waste water
- Quiet production; no noisy harvest cycles
- Slide out electrical box with diagnostic circuit board

Accessories

- Water filter kit (item# 00130229)
- 4" (102 mm) leg kit (item# AF10LBLEGS)
- Base stand (item# AF12CABINET)
- SafeCLEAN™ environmentally friendly icemaker cleaner (item# 00132001)

JOB: _____

ITEM: _____

12 Series (ice-only)

Symphony™ countertop ice dispensers with Maestro™ Chewblet® ice icemaker

Front View

Side View

Rear View

Shown with lever dispensing (-LI); infrared SensorSAFE dispensing (-SI) available

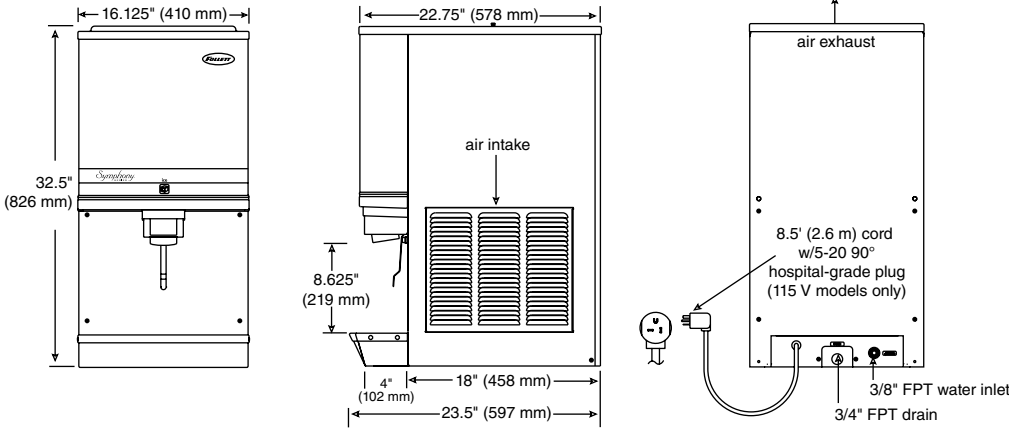

- Utilities connect through back or bottom. Back entry shown.
- See Dispenser Detail Sheet, form# 2075, for counter cut outs

Ice Production

Air-cooled icemaker capacity/24 hrs.

		Ambient Air Temperature °F/°C						
		F	60	70	80	90		100
Inlet Water Temperature °F/C	F	50	468	417	366	317	268	lbs.
	C	10	212	189	166	144	122	kg.
	F	60	450	402	354	298	243	lbs.
	C	16	204	182	161	135	110	kg.
	F	70	432	387	342	280	217	lbs.
	C	21	196	176	155	127	98	kg.
	F	80	410	369	328	271	214	lbs.
	C	27	186	175	149	123	97	kg.
	F	90	387	351	314	262	210	lbs.
	C	32	176	159	142	119	95	kg.

Energy Consumption

KWH per 100 lbs (46 kg) ice†	
Air-cooled	5.7

† Air temp. 90 F (32 C); water temp. 70 F (21 C)

Heat Rejection Data

Model	Heat rejected in BTU/hr	
	to air	to water
Air-cooled	5000	N/A

Water consumption

12.6 gal (48 L) of potable water usage per 100 lbs (46 kg) of ice.

Clearances

	Air-cooled
Required for ventilation	6" (153 mm) top and right side
Recommended for service	12" (305 mm) top

Standard Electrical – 115 V, 60 Hz, 1 phase, 13 amps, max. fuse 20 amps. 8.5 ft (2.6 m) cord and NEMA 5-20 hospital-grade plug provided with each dispenser. If local code requires hard-wiring, separate disconnects also required.

Approximate Shipping Weight 199 lbs (90 kg)

Specifications Ice dispenser to be Follett® automatic load, countertop configuration, with 12 lbs (5.4 kg) of storage. Dispenser cabinet to be of stainless steel. Environmentally friendly R404A air-cooled icemaker to have 24 hour production capacity of approximately 400 lbs (181 kg) of Chewblet compressed nugget ice at water temp. of 70 F (21 C); air temp. of 90 F (32 C). Icemaker to be equipped with printed circuit board and diagnostics to allow simplified servicing. Dispenser to have automatic bin level control to start and stop icemaker. Storage area to be insulated with non-CFC, high density, foamed-in-place polyurethane. 8.5 ft (2.6 m) cord and NEMA 5-20 hospital-grade plug provided. Dispenser to be NSF, UL and cUL listed.

Maestro, SafeCLEAN, SensorSAFE and Symphony are trademarks of Follett Corporation. Chewblet and Follett are registered trademarks of Follett Corporation, registered in the US. Follett reserves the right to change specifications at any time without obligation. Certifications may vary depending on country of origin.