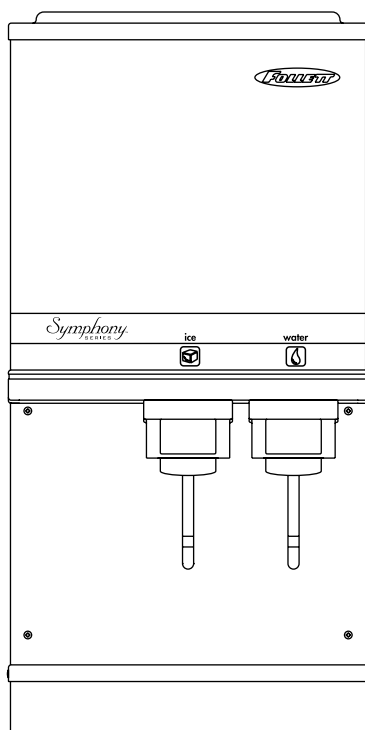


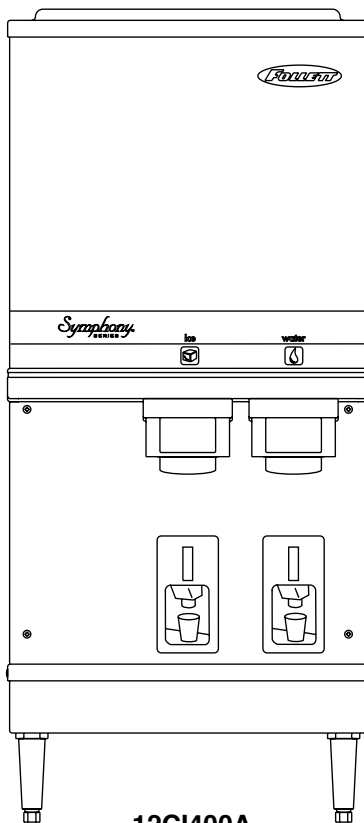
# *Symphony* 12 Series Ice and Water Dispensers

Order parts online  
[www.follettice.com](http://www.follettice.com)

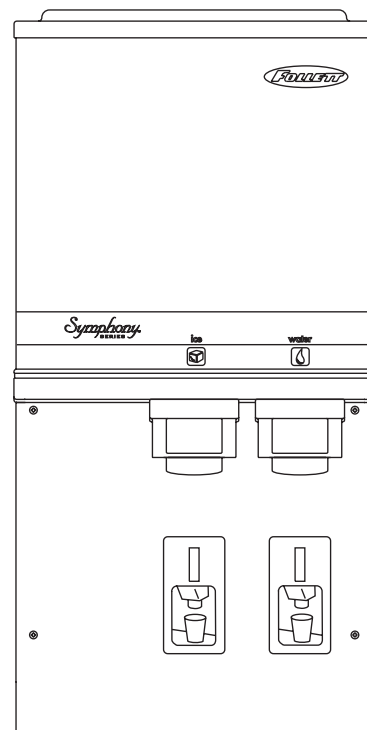
## Installation, Operation and Service Manual



**12CI400A**  
countertop dispenser



**12CI400A**  
countertop dispenser with  
SensorSAFE™ actuation  
(shown with legs accessory)



**12HI400A**  
wall mount dispenser (available  
with or without drain pan)

**Following installation, please forward this manual  
to the appropriate operations person.**

# Table of contents

<b>Welcome to Follett Corporation</b> .....	3
<b>Important cautions</b> .....	3
<b>Specifications</b> .....	4
<b>Installation</b> .....	5
Installing countertop dispensers without legs .....	5
Installing countertop dispenser with legs accessory .....	6
Installing wall mount dispensers .....	7
<b>User information</b> .....	10
Cleaning and sanitizing procedures .....	10
Dispenser cleaning .....	10
Icemaker cleaning and sanitizing .....	11
Start-up following cleaning .....	12
<b>Service information</b> .....	13
Wiring diagram – lever model .....	14
Wiring diagram – SensorSAFE™ model.....	15
Icemaker operational and diagnostic sequences .....	16
Refrigeration cycle diagram .....	21
Icemaker capacity chart .....	22
Icemaker data .....	22
Refrigeration system data and requirements .....	23
Dispenser troubleshooting – lever models .....	24
Dispenser troubleshooting – SensorSAFE models .....	25
Icemaker troubleshooting .....	26
Disassembly and replacement instructions .....	28
<b>Replacement parts</b> .....	32

**Follett Corporation  
Equipment Return Policy**

Follett equipment may be returned for credit under the following conditions:

1. The equipment is new and unused.
2. A return authorization number has been issued by customer service within 30 days after shipment.
3. Follett receives the equipment at the factory in Easton, PA within 30 days after issuance of the return authorization number.
4. The equipment must be returned in Follett packaging. If the packaging has been damaged or discarded, Follett will forward, at the customer's expense, new packaging.

**Note:** Return freight charges are the responsibility of the customer. If equipment is returned and is damaged because of improper packaging, Follett Corporation will not be held responsible.

Credit will be issued when:  
The equipment has been inspected by Follett and deemed suitable to be returned to stock.

**Note:** A 15% restocking charge will be deducted from the credit. If the cost to return the product to stock exceeds 15%, the actual cost will be deducted.

# Welcome to Follett

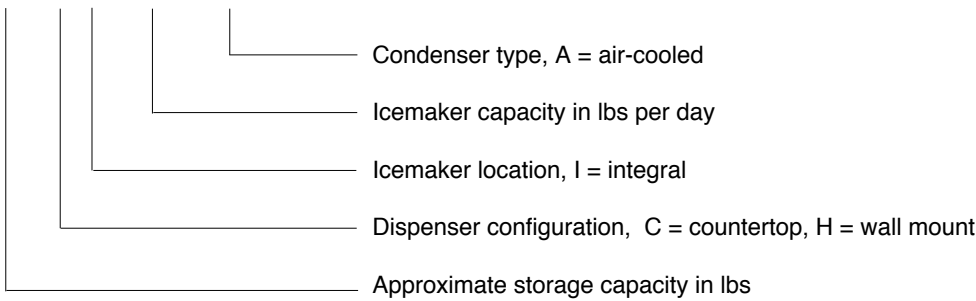
Follett equipment enjoys a well-deserved reputation for excellent performance, long-term reliability and outstanding after-the-sale support. To ensure that this equipment delivers that same degree of service, we ask that you take a moment to review the installation portion of this manual before beginning to install the unit. Our installation instructions are designed to help you achieve a trouble-free installation. Should you have any questions or require technical help at any point, please call our technical service group at (800) 523-9361 or (610) 252-7301.

## Before you begin

After uncrating and removing all packing material, inspect the equipment for concealed shipping damage. If damage is found, notify the shipper immediately and contact Follett Corporation so that we can help in the filing of a claim, if necessary.

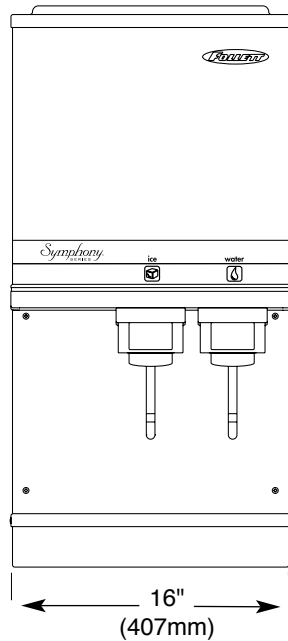
Check your paperwork to determine which model you have. Follett model numbers are designed to provide information about the type and capacity of Follett ice dispensing equipment. Following is an explanation of the different model numbers.

## 12CI400A

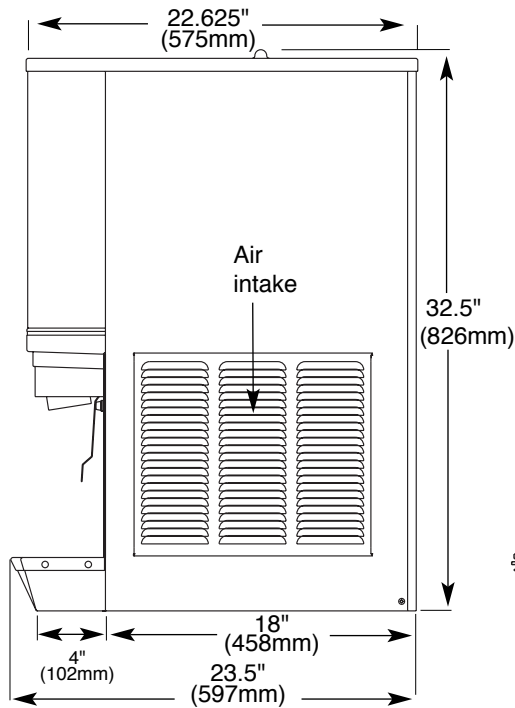


### Important cautions

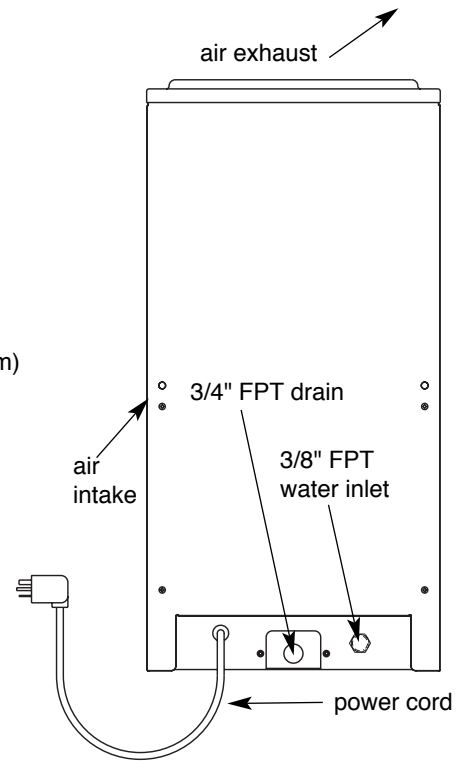
- Do not tilt any unit further than 30° off vertical during uncrating or installation
- Dispenser bin area contains mechanical, moving parts. Keep hands and arms clear of this area at all times. If access to this area is required, power to unit must be disconnected first.
- Follett recommends a Follett QC4-FL4S water filter system (item# 00130299) be installed in the icemaker inlet water line
- Prior to operation clean and sanitize the dispenser in accordance with instructions found in this manual
- Ice is slippery. Be sure counters and floors around dispenser are clean, dry and free of ice.
- Do not block right side air intake or top air exhaust



Dispenser front view



Dispenser side view



Dispenser rear view

## Specifications

### Electrical

115V, 60Hz, 1 phase, 13.0 amps. Connect to 20 amp circuit, fuse or breaker.

**Note:** It is preferred that circuit be protected by a GFCI.

Furnished with 6 ft (1.8m) power cord with a 90° hospital grade 5-20 plug

### Ambient

Air temp	100°F/38°C Max.	50°F/10°C Min. (Best performance below 80°F/27°C)
Water temp	90°F/32°C Max.	40°F/4°C Min. (Best performance below 70°F/21°C)
Water pressure	70 P.S.I. Max.	10 P.S.I. Min.

### Plumbing

	12CI400A	12HI400A
Dispenser drain	3/4" FPT	3/4" FPT
Water inlet	3/8" FPT	3/8" FPT

**Note:** Water shut-off recommended within 10 feet (3m) of dispenser. Drain to be hard-piped and insulated. Maintain at least 1/4" per foot (20mm per 1m run) of slope.

### Ventilation clearances

6" (153mm) on right side of dispenser, 6" (153mm) at top for ventilation and 12" (305mm) at top recommended for service.

**Note:** Do NOT block right side air intake or top air exhaust.

### Dry weight

175 lbs (79.4kg)

# Installation

## Before you begin

All dispensers must be installed level in both directions to ensure proper operation.

Service and ventilation clearances: 6" (153mm) on right side of dispenser, 6" (153mm) at top for ventilation and 12" (305mm) at top recommended for service.

Countertop units installed without legs provide the option of taking utilities out bottom or back of dispenser (on wall mount units and countertop units with legs, utilities exit from back). See counter cutout drawings for bottom exiting utilities on units with and without drain pans. For installations where utilities exit through back of dispenser, refer to back view drawings.

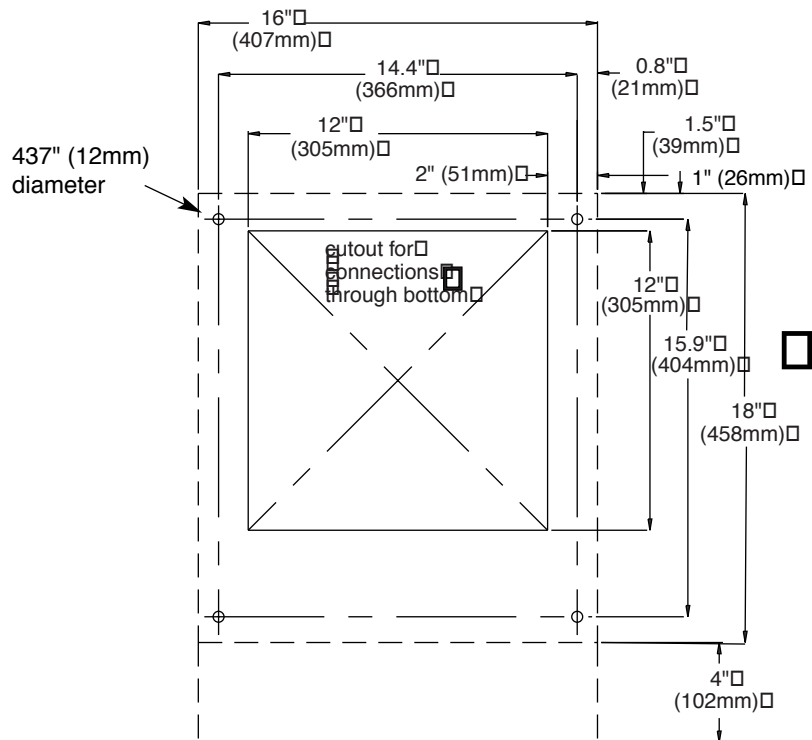
Wall mount models without drain pan are designed for use above sinks.

Counter depth must allow front of sink to be a minimum of 23.5 (597mm) from wall.

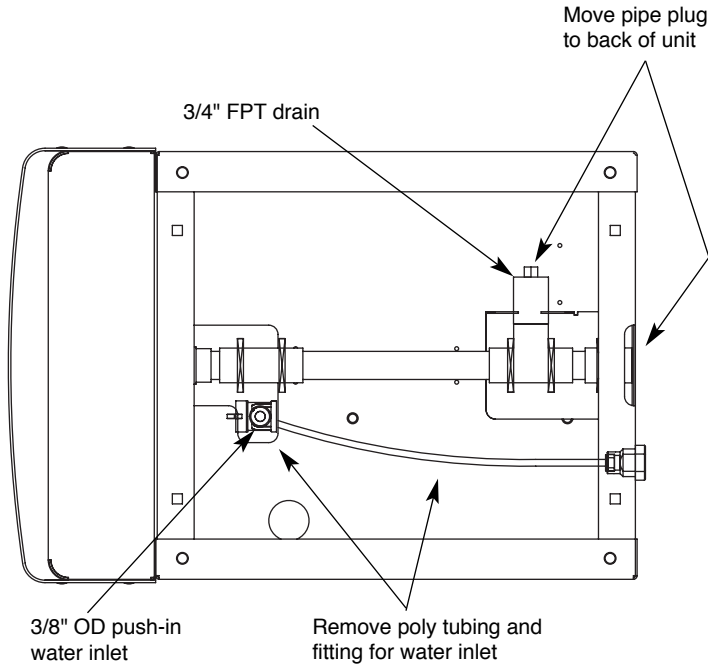
## Installing countertop dispensers without legs

1. Position dispenser in desired location, mark dispenser outline on counter and remove dispenser.
2. Regardless of whether utilities will exist through back or bottom of dispenser, drill four (4) 7/16" holes in counter to anchor dispenser to counter (Fig. 1).
3. **For utilities existing through bottom only:**
  - (a) Make cut out as shown in Fig. 1.
  - (b) Move plug from drain T to back of unit (Fig. 2).
4. **For all units:** Apply a thick bead approximately 1/4" (6mm) diameter of NSF listed silicone sealant (Dow Corning RTV-732 or equivalent) 1/4" (6mm) inside marked outline of dispenser.
5. Carefully lower dispenser on counter in proper position and secure to counter with four (4) 3/8"-16NC bolts.
6. Smooth excess sealant around outside of dispenser.

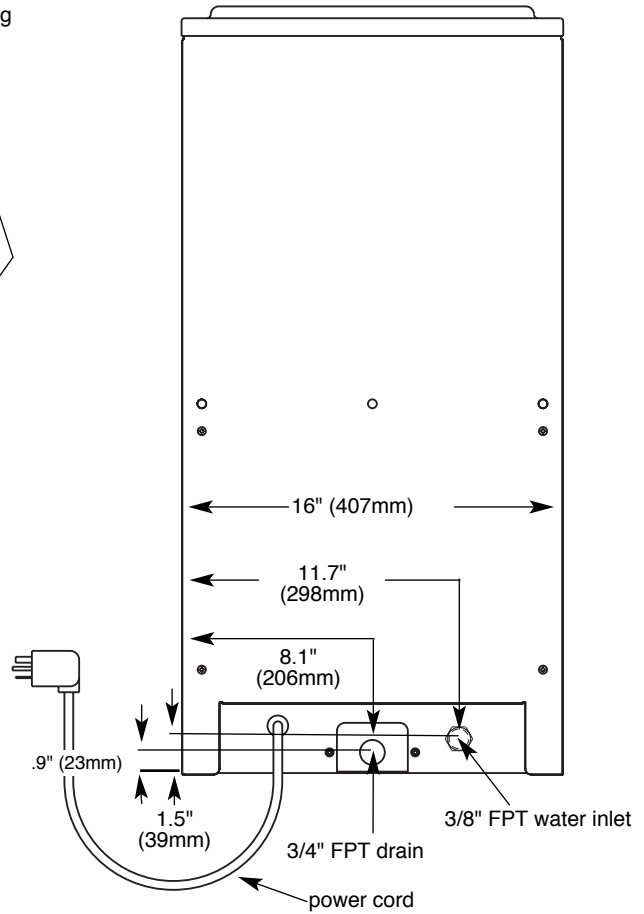
Fig. 1 – Counter information



**Fig. 2 – Bottom exiting utilities (countertop units)**



**Fig. 3 – Rear exiting utilities (countertop units)**



## Installing countertop dispensers with legs accessory

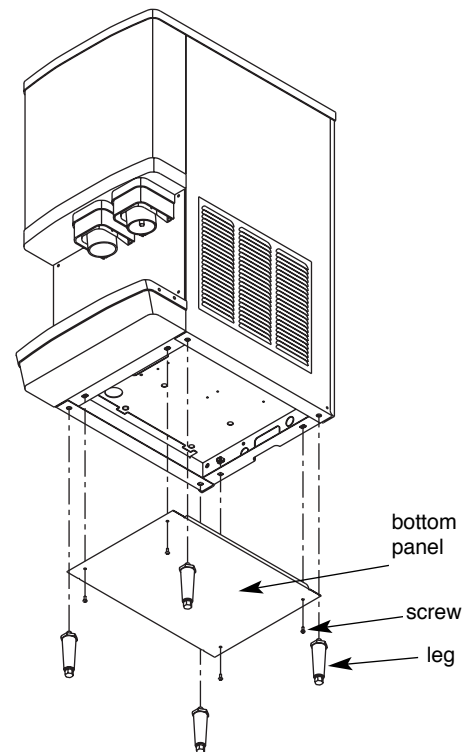


**Do NOT tilt unit farther than 30° off vertical plane.**

**Countertop dispensers that sit on legs (not bolted to counter) can be inadvertently moved. Care should be taken when operating and cleaning to avoid accidents.**

1. Carefully tip dispenser back to expose underside and block up in place.
2. Screw legs (shipped taped to drain pan of dispenser) into dispenser bottom, taking care to seat legs securely against underside of dispenser.
3. Attach bottom panel and hardware to bottom of dispenser with supplied screws (Fig. 4).
4. Position unit in desired location and adjust bullets on legs to level in both directions.
5. Make final connections.

**Fig. 4 – bottom panel assembly**



## Installing wall mount dispensers

### Notes:

No drain pan is provided since the dispenser is intended to be installed above a sink. (Contact Follett if a drain pan is desired.)

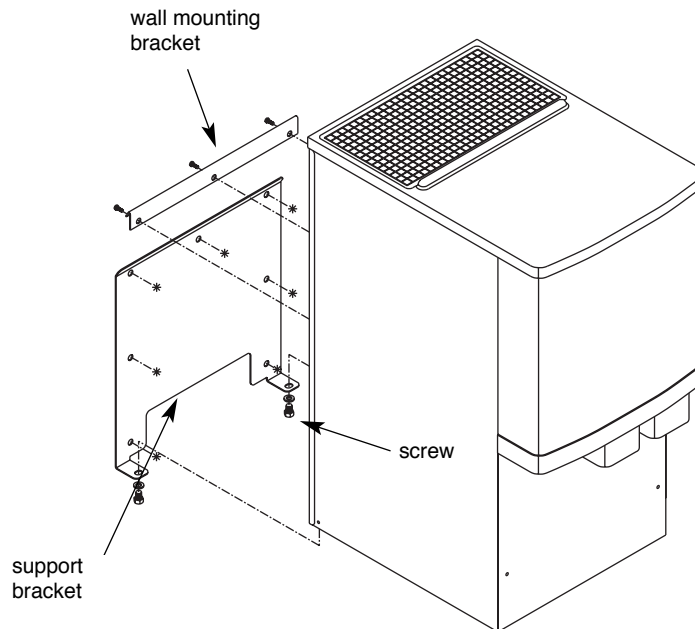
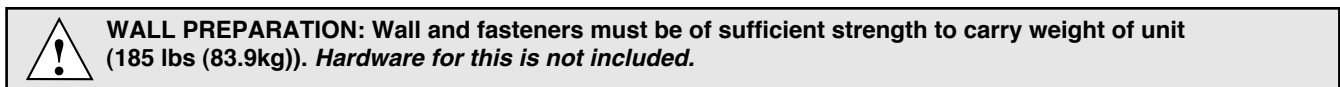
SensorSAFE actuation is standard. (Contact Follett if lever actuation is desired. A deeper cabinet will be needed.)

Recommended minimum counter depth and mounting height shown on Fig. 7 ensures that ice will drop into sink.

See Fig. 6 for model dimensions. The dimensions include the .5" (13mm) mounting bracket supplied with the unit.

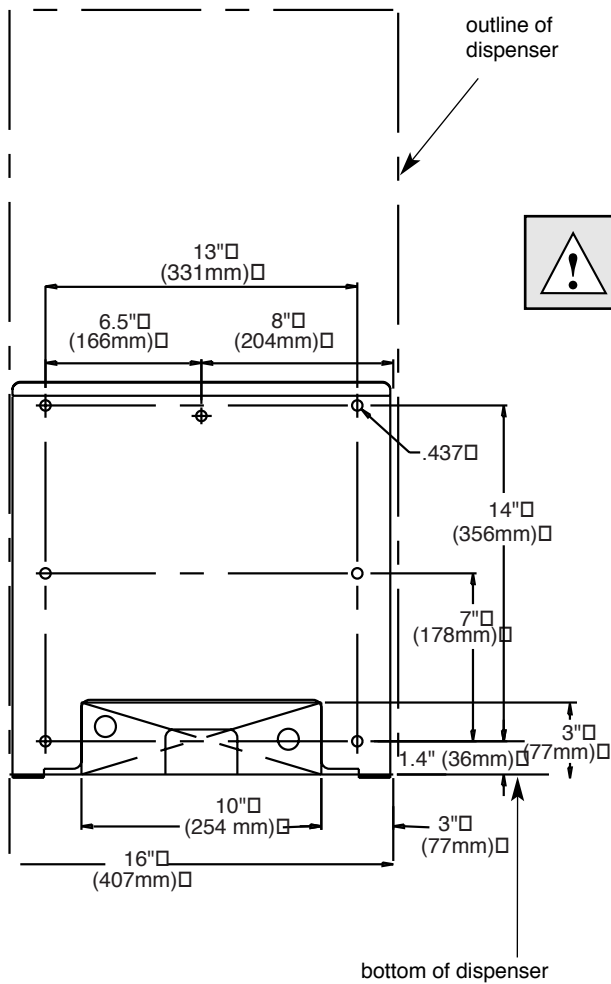
1. Cut utility hole in wall as shown (Fig. 10).
2. Mount support bracket to wall using fasteners of sufficient strength (fasteners not included, see Fig. 6).
3. Rough in water and drain lines (Fig. 10).
4. Lift dispenser onto support bracket, positioning unit so that hook on back of dispenser is captured by support bracket angle (Fig. 7).
5. Install two (2) supplied 3/8"-16NC screws through bottom of support bracket into bottom of dispenser (Fig. 5).
6. Make final connections.
7. Attach bottom panel and hardware to bottom of dispenser (Fig. 8).

**Fig. 5 – Wall mount bracket and fastener requirements**



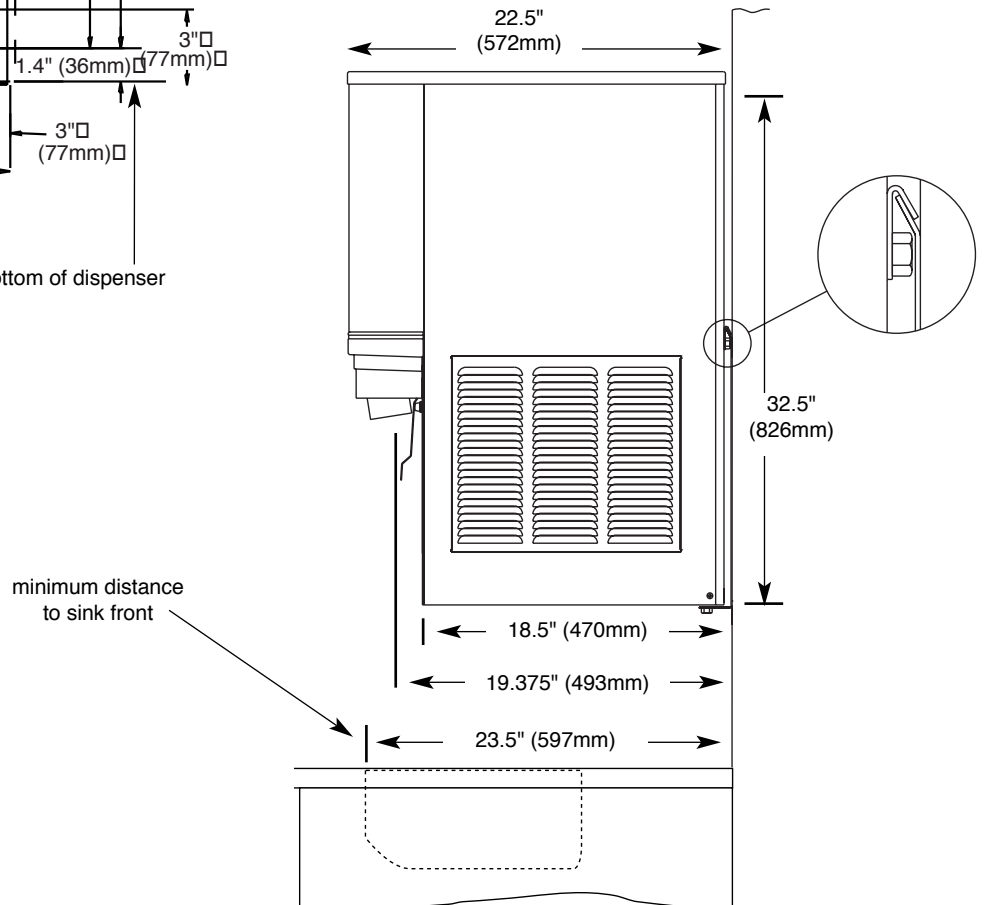
# Installing wall mount dispensers

Fig. 6 – Wall mounting dimensions



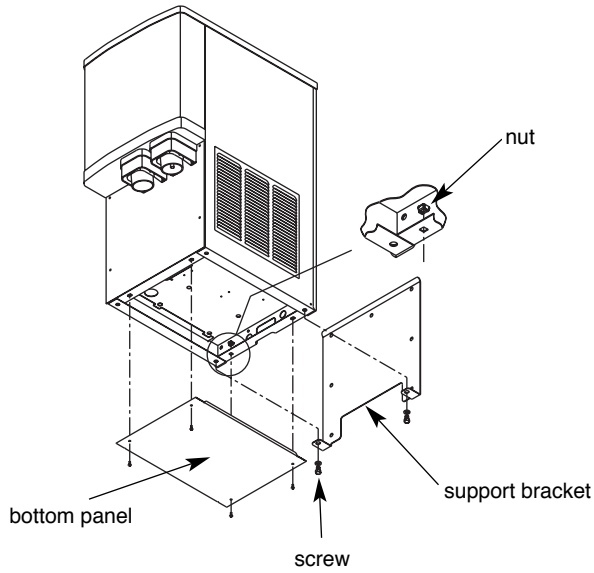
**Caution: Do NOT rest dispenser weight on bottom of support bracket.**

Fig. 7 – Wall mount side view

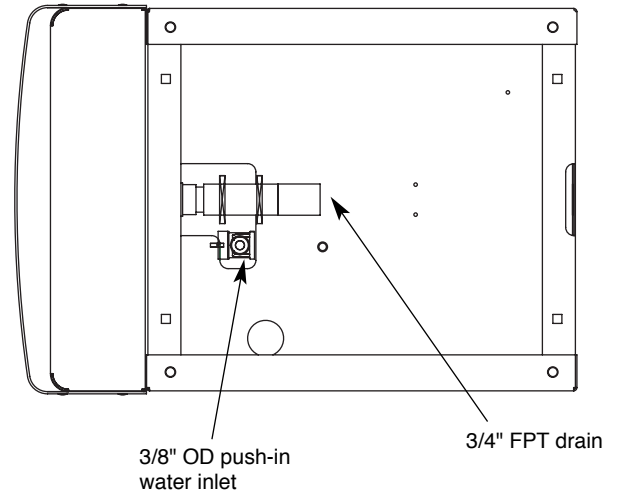




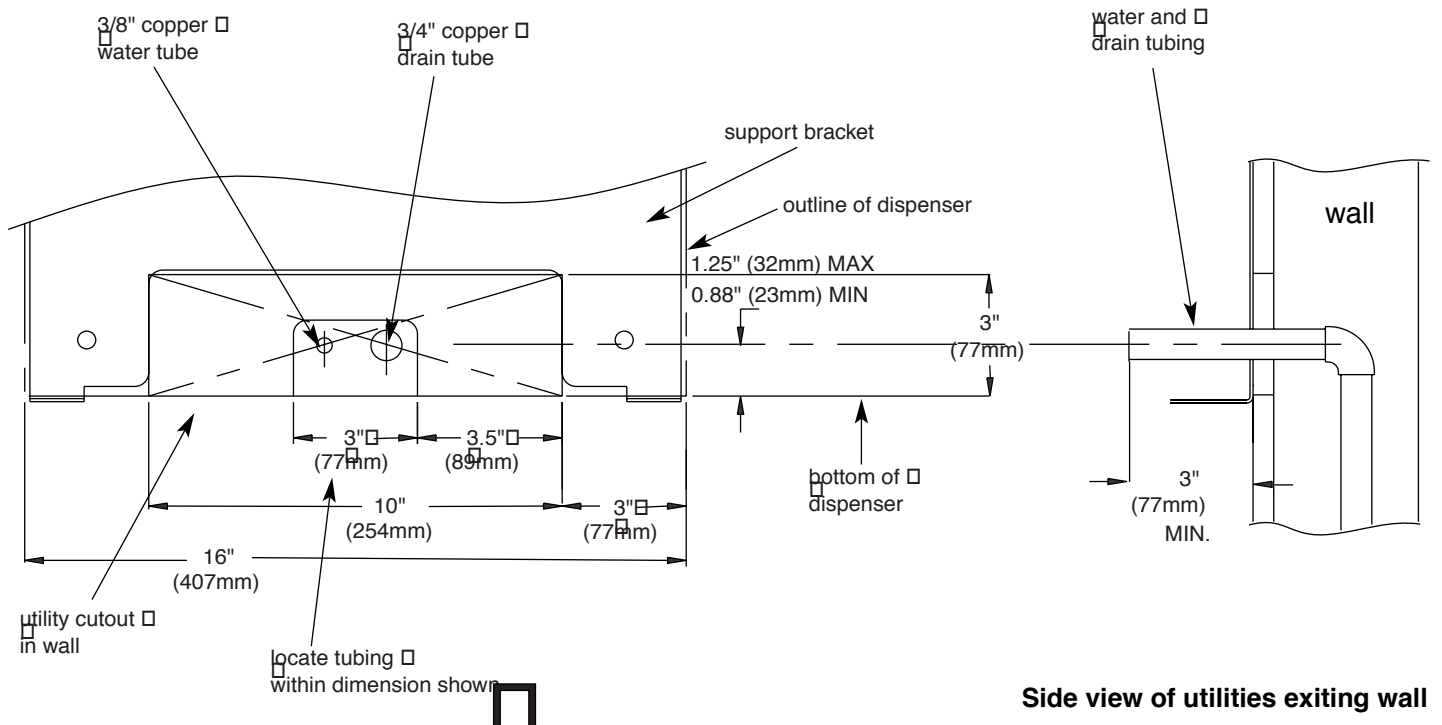
**Fig. 8 – Wall mount unit bottom panel assembly**



**Fig. 9 – Wall mount bottom view**



**Fig. 10 – Front view of wall mount bracket, utility location**



**Side view of utilities exiting wall**

# User information

## How the dispenser works

Follett's 12 series automatic-load ice and water dispensers are equipped with Follett's 400 lb (181kg)/day icemaker. In the continuous icemaking process, water freezes to the inside wall of the evaporator. A rotating stainless steel auger carries the ice to the top of the evaporator where it is compressed and extruded through an outlet port. The ice is then pushed through a tube to the storage hopper. When the hopper is full, a bin thermostat opens and shuts the icemaker off. When the dispense mechanism is activated, a dispense motor is turned on, causing the wheel to turn. This moves ice to the dispense chute where it drops by gravity into the container held below the chute.

## How the SensorSAFE accessory works

Follett's SensorSAFE accessory maximizes sanitation and minimizes the possibility of cross-contamination by eliminating physical contact between the cup or container and dispenser. Sensors in the panel use reflected infrared light to detect the presence of the container and send a signal to a control board which then activates the appropriate components for ice or water dispensing.

The SensorSAFE package includes a cleaning switch under the left side of the front cover which temporarily shuts off dispensing to allow cleaning of the panel and lenses. If the switch is not turned back on after cleaning, the dispenser automatically resets after two minutes for normal operation.

SensorSAFE also includes a time limit safety feature which automatically stops ice dispensing after one minute of continuous dispensing. Dispensing can be resumed by moving the container away from the dispenser and returning it to the activation zone.

## Cleaning and sanitizing procedures

**Solution A:** Prepare cleaning solution (200 ppm of available chlorine content) of Ecolab Mikro-chlor Cleaner or equal chlorinated detergent. Solution temperature must be 75°F – 125°F (24°C – 52°C).

**Solution B:** Prepare sanitizing solution (50 ppm of available chlorine content) of Ecolab Mikro-chlor Cleaner or equal chlorinated detergent. Solution temperature must be 75°F – 125°F (24°C – 52°C).

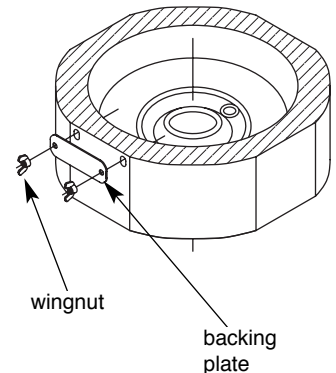
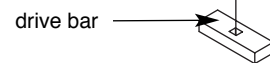
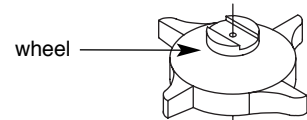
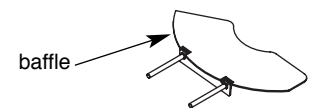
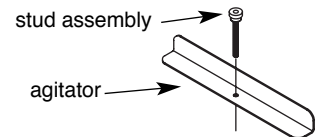
Follett recommends the periodic cleaning schedule below to ensure the quality of ice provided. Use only recommended cleaning solutions. Do not use solvents, abrasive cleaners, metal scrapers or sharp objects.



**Warning – Always disconnect power before cleaning.**

### Dispenser cleaning: start-up and quarterly intervals

1. Remove all ice from storage hopper.
2. Remove top and front cover (see page 30).
3. Remove center thumbscrew, locking plate, two wingnuts and backing plate from front of storage hopper.
4. Remove stud assembly, agitator, spacer, baffle, wheel and drive bar in this sequence.



5. Remove dispense chute.
6. Wipe lid, wheel, baffle, inside of storage area and dispense chute with damp cloth wrung out in Solution A.  
**Note:** To avoid possible damage to motor assembly, use a damp cloth only to clean storage hopper. Do not allow water to run through center hole in bottom of hopper.
7. Rinse all above items with damp cloth and wring out in clear water.
8. Sanitize all above items with damp cloth wrung out in Solution B. Do not rinse.
9. Pour 1 cup (284ml) household bleach into drain pan, followed by 1 gallon (3.8L) hot tap water to flush drains.
10. Reinstall all parts.

### **Dispenser grille and drain pan – weekly intervals**

1. Remove grille and wash with Solution A. Rinse thoroughly.
2. Pour 1 cup (282ml) household bleach into drain pan, followed by 1 gallon (3.8L) of hot tap water to flush drains.

### **Splash panel front, SensorSAFE dispensers**

1. Deactivate dispensing by pressing and releasing clean switch located on left side of unit under top front cover.
2. Clean lens using a soft cloth and mild, non-abrasive, non-chlorine based cleaner.
3. Reactivate dispensing by pressing and releasing clean switch again.

## **Icemaker cleaning & sanitizing**

Periodic cleaning of Follett's icemaker system is required to ensure peak performance and delivery of clean, sanitary ice. The recommended cleaning procedures which follow should be performed at least as frequently as recommended below and more often if environmental conditions dictate.

Cleaning of the condenser can usually be performed by facility personnel. Cleaning of the icemaker system in most cases should be performed by your facility's maintenance staff or a Follett authorized service agent. Regardless of who performs the cleaning, it is the operator's responsibility to see that this cleaning is performed according to the schedule below. Service problems resulting from lack of preventive maintenance will not be covered under the Follett warranty.

## **Cleaning procedures**

### **Recommended monthly cleaning of condenser (air-cooled icemaker only)**

1. Use a vacuum cleaner or stiff brush to carefully clean condenser coils of air-cooled icemakers to ensure optimal performance.
2. When reinstalling counter panels in front of remote icemakers, be sure that ventilation louvers line up with condenser air duct.

### **Recommended semi-annual cleaning of icemaking system**

Icemaking system can be cleaned in place without disassembling water system. Cleaning should be performed at least every 6 months, and more often if local water conditions dictate.

1. Disconnect power to icemaker.
2. Remove any icemaker panels required to gain access to water reservoir and electrical control box.
3. Turn compressor switch on electrical box of icemaker to OFF position.
4. Remove water reservoir cover and block up reservoir float or close water supply valve.
5. Drain water from reservoir by releasing evaporator drain line from float reservoir bracket and removing plug from drain line.

6. Following manufacturer's instructions, prepare one gallon (3.8L) of Follett SafeCLEAN Ice Machine Cleaner (one 7 oz packet) or equivalent. Solution temperature must be at least 120° F (48.9° C).  
**WARNING:** Most ice machine cleaners contain citric or phosphoric acid that can cause skin irritation. Read caution label on product and follow instructions carefully.
7. Plug drain hose, replace drain line in reservoir bracket and pour part of cleaning solution into reservoir, filling it almost to overflowing.
8. Remove stainless steel compression nozzle and drain lines. Submerge in a cup of cleaning solution while cleaning rest of system. (Flake icemakers have no compression nozzle and drain lines.)  
**CAUTION:** To avoid potential pitting, do not soak parts in SafeCLEAN for more than 45 minutes.
9. Restore power to icemaker (garmotor will run; compressor and fan will not).
10. After 15 minutes, turn power OFF; drain solution from reservoir and evaporator.
11. Fill reservoir almost to overflowing with clean, 120° F (48.9° C) water, and drain. Repeat three times.
12. Following manufacturer's instructions, prepare 1 gallon (3.8L) of 200ppm 5.25% Sodium Hypochlorite solution (mix 1 oz household bleach to 2 gallons water) or equivalent. Solution temperature must be at least 120° F (48.9° C).
13. Rinse compression nozzle in clean water and submerge in a cup of sanitizing solution while following steps 14-19.
14. Connect ice transport tube directly onto evaporator outlet port without compression nozzle.  
**NOTE:** If bin will not be cleaned at this time, place a large pan in bin storage area to catch ice or connect a separate ice transport tube to evaporator and divert ice into separate container.
15. Fill reservoir almost to overflowing with sanitizing solution.
16. Restore power to icemaker (garmotor will run; compressor and fan will not).
17. After 10 minutes, turn compressor switch to ON position.
18. As unit starts to make ice, continue to pour sanitizing solution into reservoir, maintaining level just below reservoir overflow.
19. Continue to make ice with sanitizing solution for 20 minutes.
20. Turn power to icemaker OFF.
21. Disconnect transport tube from evaporator outlet port. Rinse compression nozzle in clean water and reinstall on evaporator outlet. Reconnect transport tube to compression nozzle.
22. Drain any remaining sanitizing solution from evaporator.
23. Fill reservoir almost to overflowing with clean, 120° F (48.9° C) water, and drain. Repeat three times.
24. Unblock float (or open water supply valve) and replace reservoir cover; restore power to icemaker and ensure compressor switch is in ON position. Make ice for at least 15 minutes to flush any remaining solution from system (remote icemakers with long ice transport hoses may take longer to flush out). Discard this and all ice made during sanitizing.
25. Inspect evaporator drain pan and drain line and remove any accumulated scale build up.
26. Replace any panels removed prior to cleaning.

### **Start-up following cleaning**

1. Clean and sanitize ice storage area of dispenser in accordance with instructions above before making ice.
2. Turn icemaker on and begin to make ice (icemaker should start immediately with power and bin signal supplied).
3. After approximately 30 minutes, test dispenser for proper dispensing.

# Service

## Important preliminary information

Follett's icemaker consists of four distinct functional systems.

- Refrigeration system
- Water system
- Harvesting system
- Electrical control system

These four systems work together to accomplish the production and harvesting of ice. A problem in any one of these system areas will result in improper operation of the entire ice production cycle. When troubleshooting the icemaker, it is important to analyze the entire system operation to determine which system is not functioning properly, then pinpoint the component within that system that is malfunctioning. Determine what corrective action must be taken before making any adjustments or replacing any components.

**Note:** When performing electrical service, always use a meter to determine whether or not components being serviced are energized.

## The icemaking process

The Follett icemaker uses a stainless steel jacketed evaporator and operates on a continuous freezing cycle. Water is supplied to the evaporator from the water reservoir where the water level is controlled by a float valve. This valve also shuts off the water supply when the icemaker is not running.

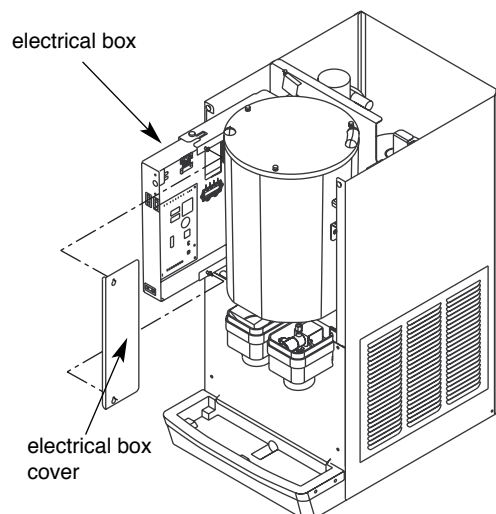
When the icemaker is running, a layer of ice forms on the interior surface of the evaporator. This ice is continuously removed by a slowly rotating (12 RPM) auger. The auger carries the ice upward into the cavity formed by the top bearing housing and the compression loop, where it is compressed to remove excess water. When the ice reaches the desired hardness it rotates within the cavity and is forced through a discharge port and compression nozzle and into the ice transport tube. The discharge tube and compression nozzle are slightly restricted to further compress the ice and produce the desired high quality. As the formation of ice continues, ice in the transport tube is pushed through the tube to the storage compartment in the ice dispenser or ice storage bin.

A solid state control board located in the electrical box of the icemaker controls the normal operation of the icemaker and monitors gearmotor torque on an ongoing basis. This control board will shut down the icemaker should an over-torque condition occur. It is very important that you familiarize yourself with the operational sequences detailed in this manual before attempting to service the icemaker.

### Access to electrical box and control board

The 12 series electrical box has been designed to slide out for easy access to the control board and more convenient troubleshooting.

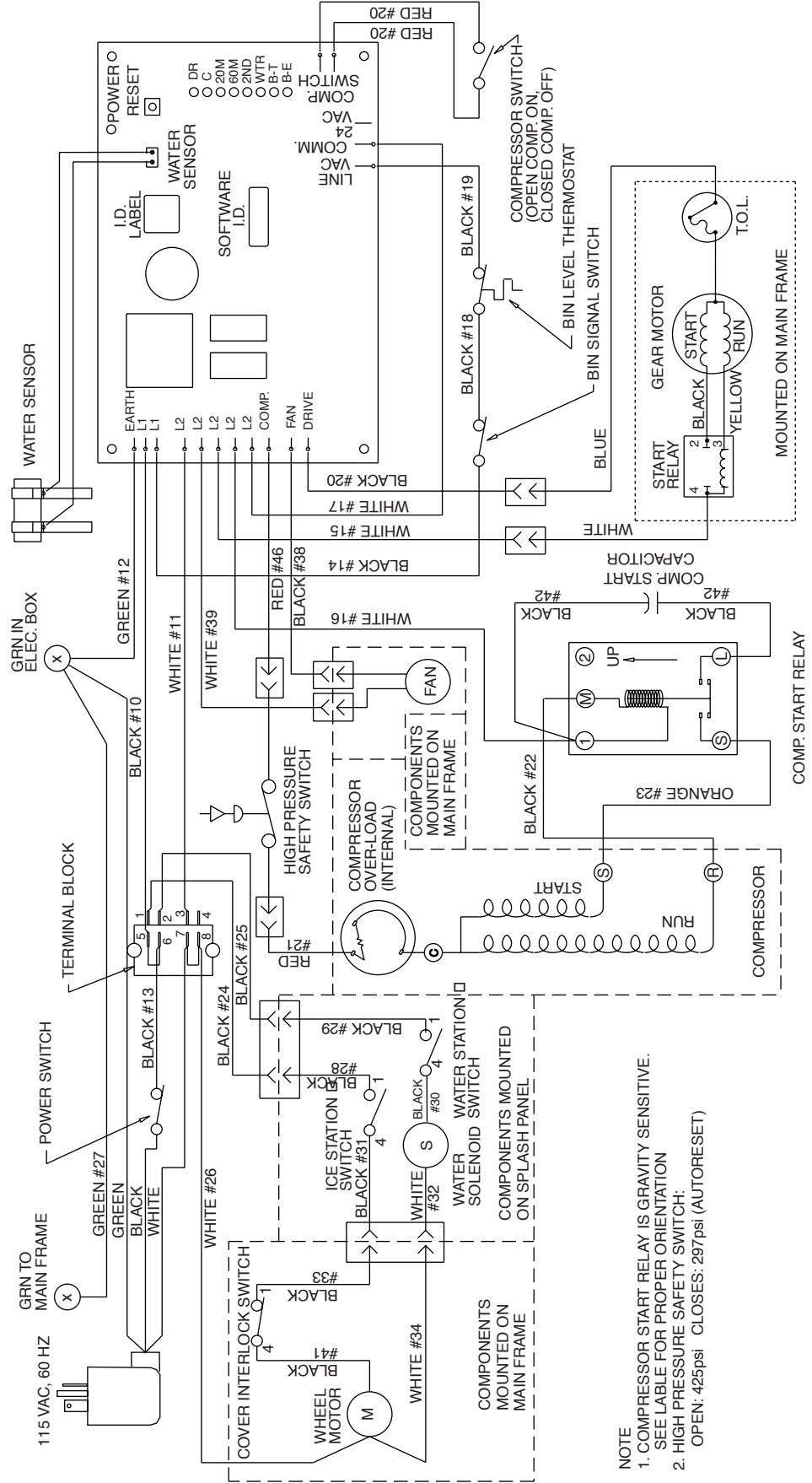
1. Remove top and front panels of dispenser (for panel removal instructions see pg. 30).
2. Remove electrical box cover.
3. Pull electrical box toward front of unit.



# Wiring diagram – lever model

## How the unit works – lever model

The dispense wheel motor is energized through the power, dispense and cover interlock switches. The bin signal circuit is completed through the normally closed contacts of the bin thermostat and the bin signal switch. When ice builds up around the bin thermostat, the contacts opens, cutting the bin signal circuit.



# Wiring diagram – SensorSAFE model

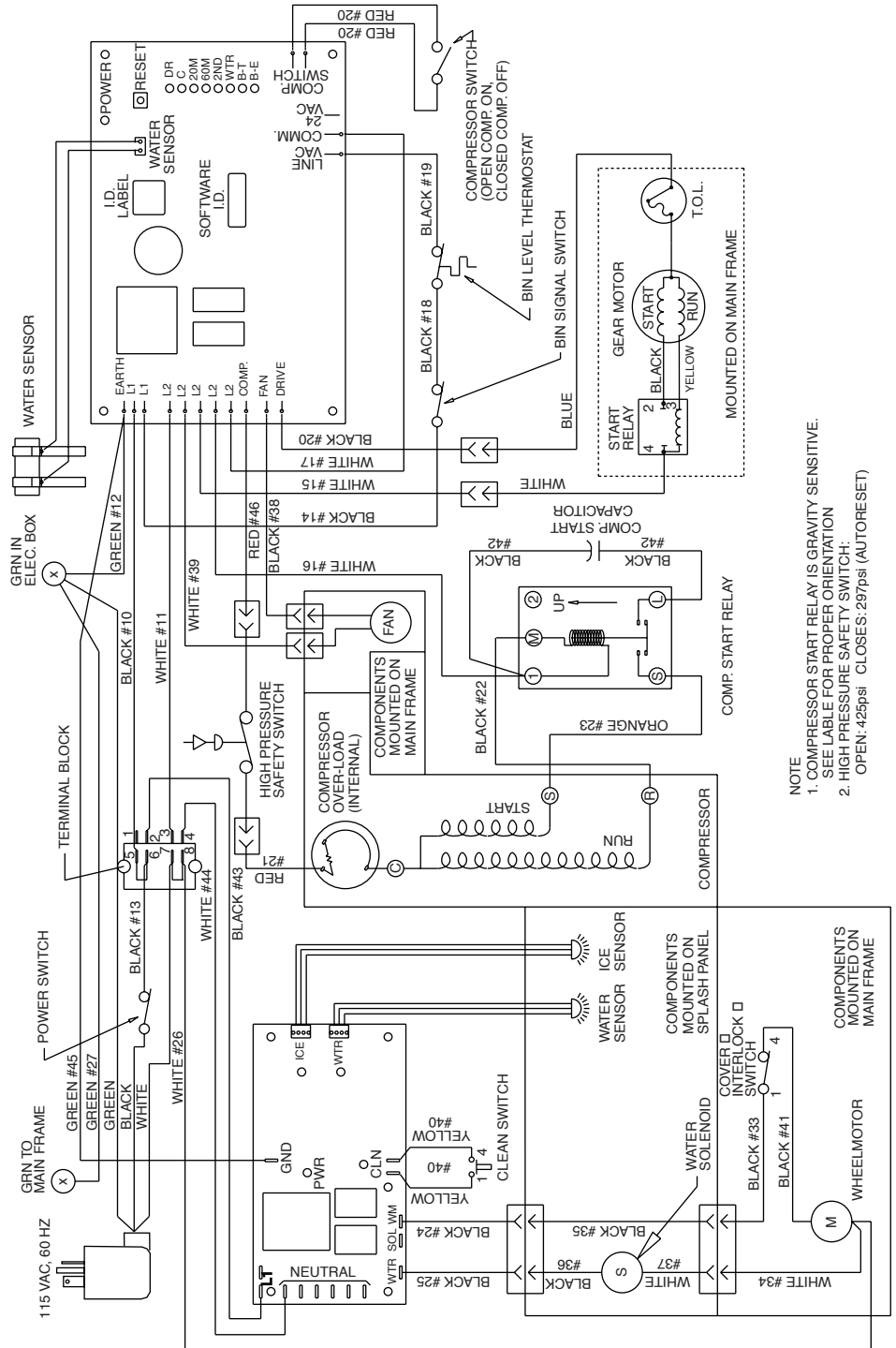
## How the unit works – SensorSAFE model

SensorSAFE models provide “touchless” ice and water dispensing. When a container is placed within the actuation zone below the ice or water chute, an invisible, randomly-generated infrared signal is emitted, reflected off the container and detected by the sensor. The sensor then sends a signal to the control board to activate the appropriate components to dispense ice or water. LEDs on the board indicate when the board is receiving a signal from the sensors.

A safety, shut-off feature automatically shuts off dispensing after one minute of continuous activation. Dispensing can be restarted by moving the container away and then returning it to the actuation zone.

Dispensing can be temporarily suspended by depressing and releasing the clean switch, located under the left side of the top front cover. Depressing and releasing the button a second time will return the dispenser to normal operating state. If the clean switch is not depressed a second time, the dispenser will automatically resume normal dispense operation (CLN LED goes out) after two minutes. An LED on the control board will light to indicate that the dispensing has been suspended by activation of the clean switch.

The bin signal circuit is completed through the normally closed contacts of the bin thermostat and the bin signal switch. When ice builds up around the bin thermostat, the contacts open, cutting the bin signal.



NOTE  
 1. COMPRESSOR START RELAY IS GRAVITY SENSITIVE. SEE LABEL FOR PROPER ORIENTATION  
 2. HIGH PRESSURE SAFETY SWITCH: OPEN: 425psf CLOSES: 297psf (AUTORESET)

# Icemaker operational and diagnostic sequences

The wiring diagrams that follow illustrate the circuitry of Follett icemakers used with 12 series ice dispensers. Both normal operation (stages 1 - 6) and non-normal diagnostic sequences showing torque-out (stages 7 - 10) for use in troubleshooting are shown.

## Circuitry notes

Compressor switch should read open in ON position.

Compressor start relay is position sensitive. See label on start relay for proper orientation.

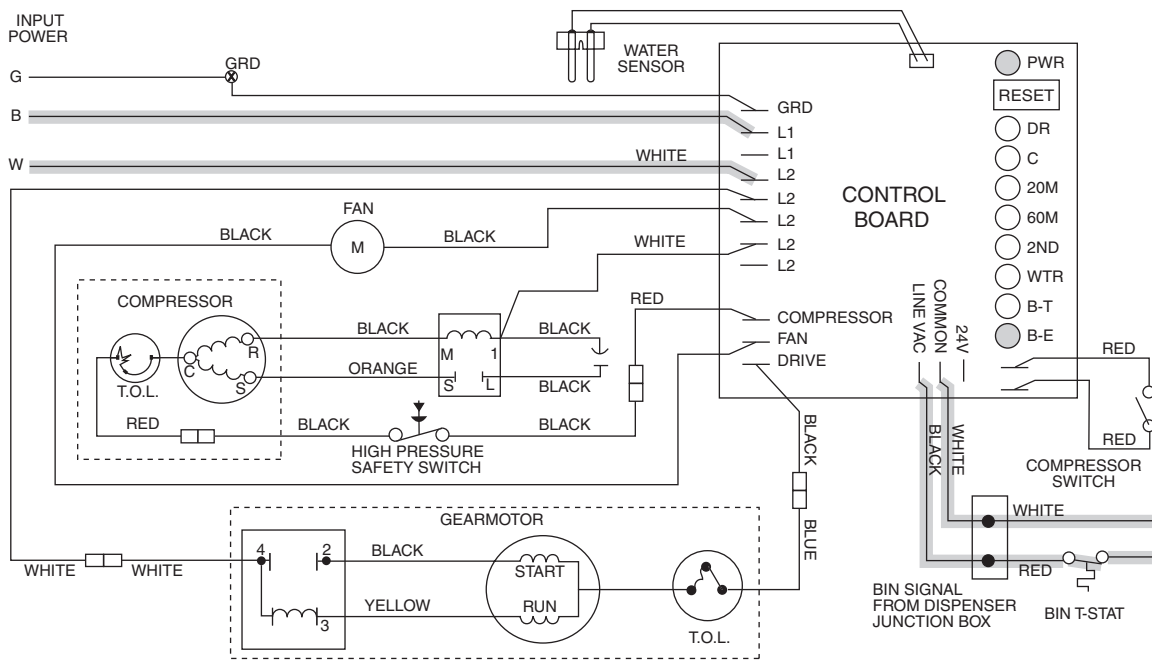
Bin signal is 115V, 60Hz.

Flashing water LED at any time indicates that water signal to board has been lost for more than one second.

Ten-second delay: There is a 10 second delay in reaction to loss of water (WTR) or bin (B-E) signals. If signals are not lost for more than 10 seconds, no reaction will occur.

## Normal operation – Stage 1

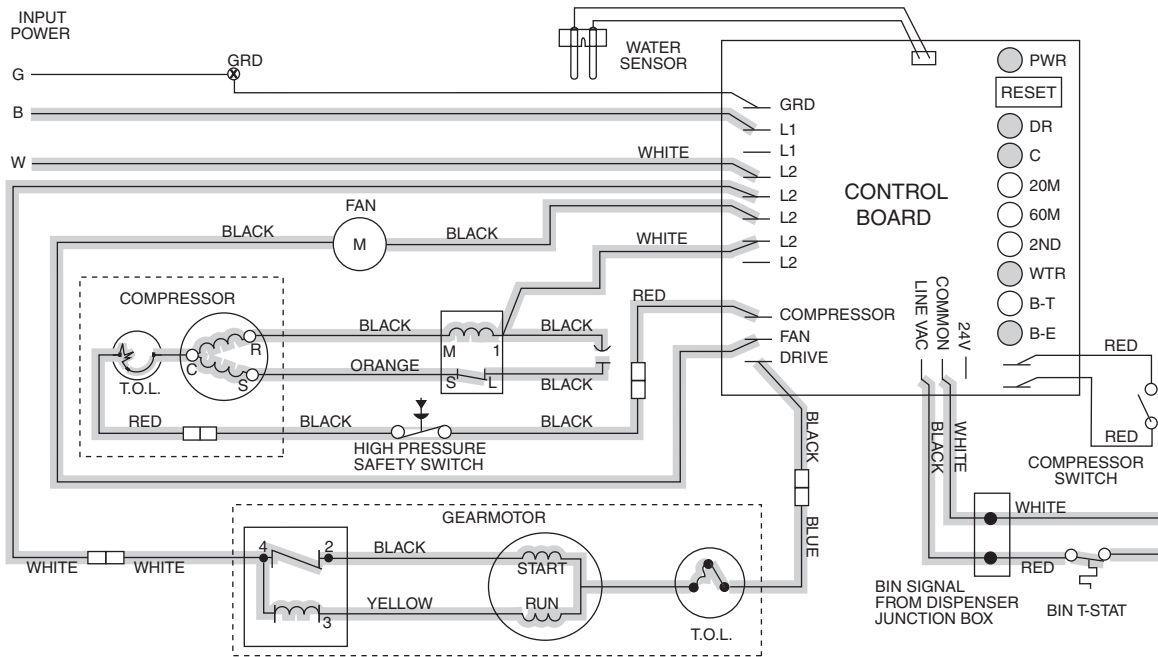
Power is supplied to L1 of the control board. The ice level control in the dispenser is closed and calling for ice, supplying signal voltage to the control board. The control board will now go through the start-up sequence. Less than 30 seconds will elapse as the water sensor located in the float reservoir checks for water in the reservoir. The bin empty LED (B-E) and power LED (PWR) will be on.





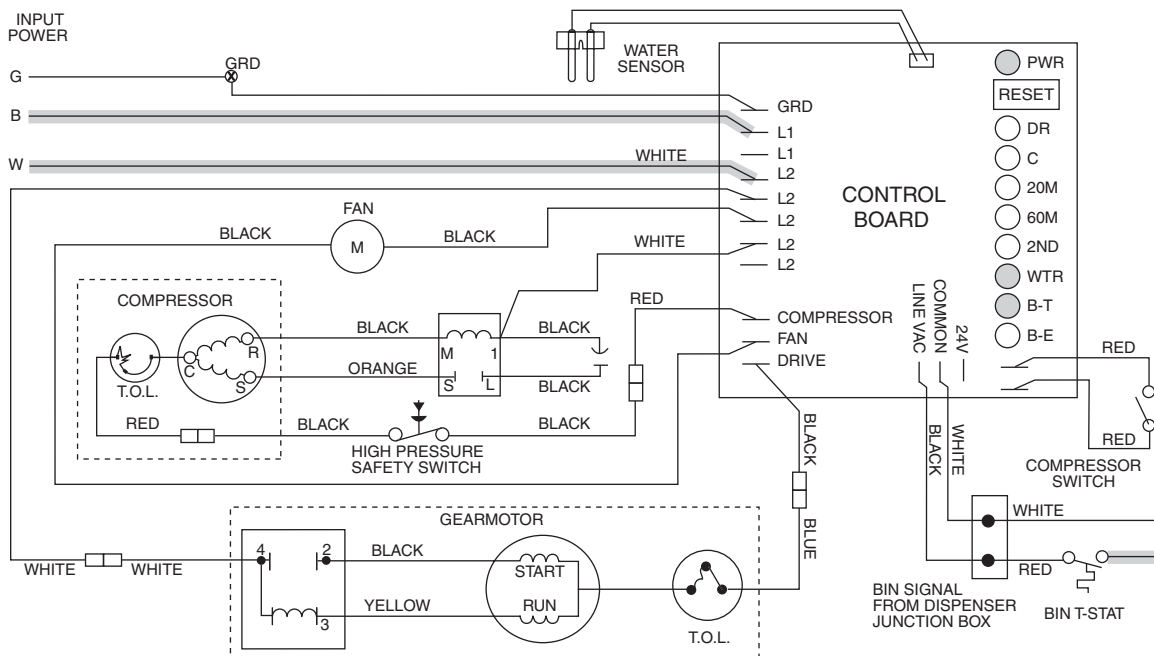
### Normal operation – Stage 2

The water sensor verifies water in the float reservoir. The water OK LED (WTR) comes on. At the same time, the gearmotor, compressor and condenser fan motor come on, lighting the drive LED (DR) and compressor LED (C). The high initial current draw of the compressor run winding closes the contacts of the current relay energizing the start winding through the run capacitor. The gearmotor is also started through a current style relay that is pulled in by the initial high current draw of the run winding. The PWR, B-E and WTR LED remain on.



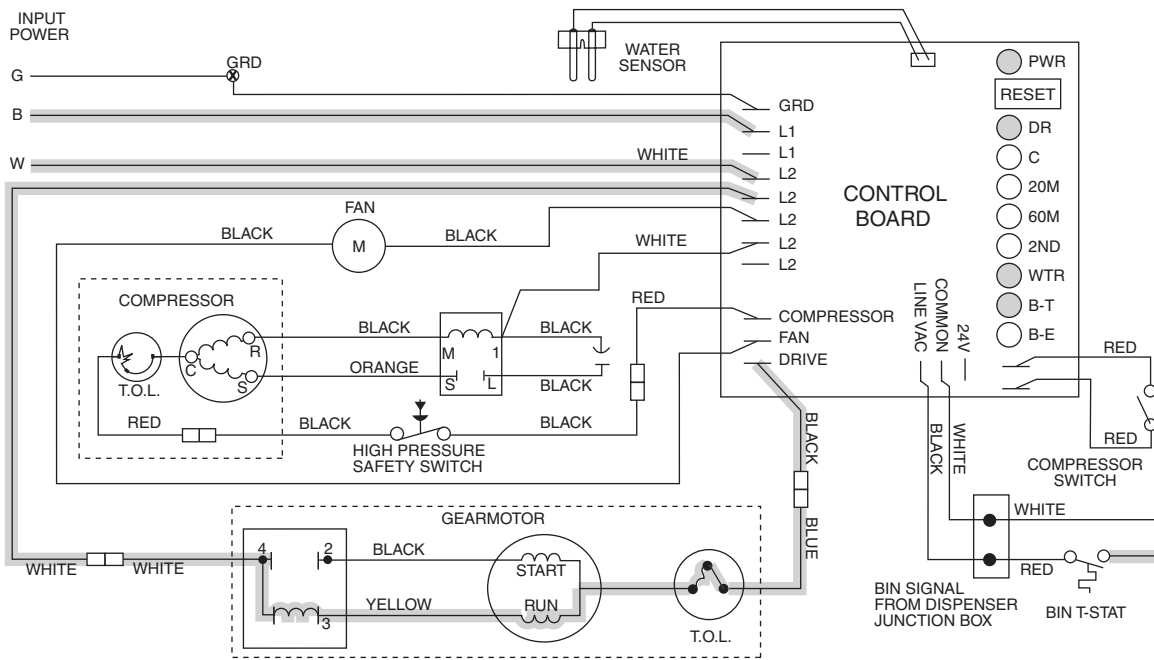
### Normal operation – Stage 3

After the initial high current draw drops off, the gearmotor start relay contacts open, dropping out the start winding. As the compressor comes up to normal running speed, the compressor start relay contacts also open, dropping out the start winding of the compressor. The icemaker is now in a normal icemaking mode. The icemaker will begin to produce ice and continue to produce ice until the bin level control in the ice dispenser is satisfied. The PWR, B-E, DR, C and WTR LEDs are all on.



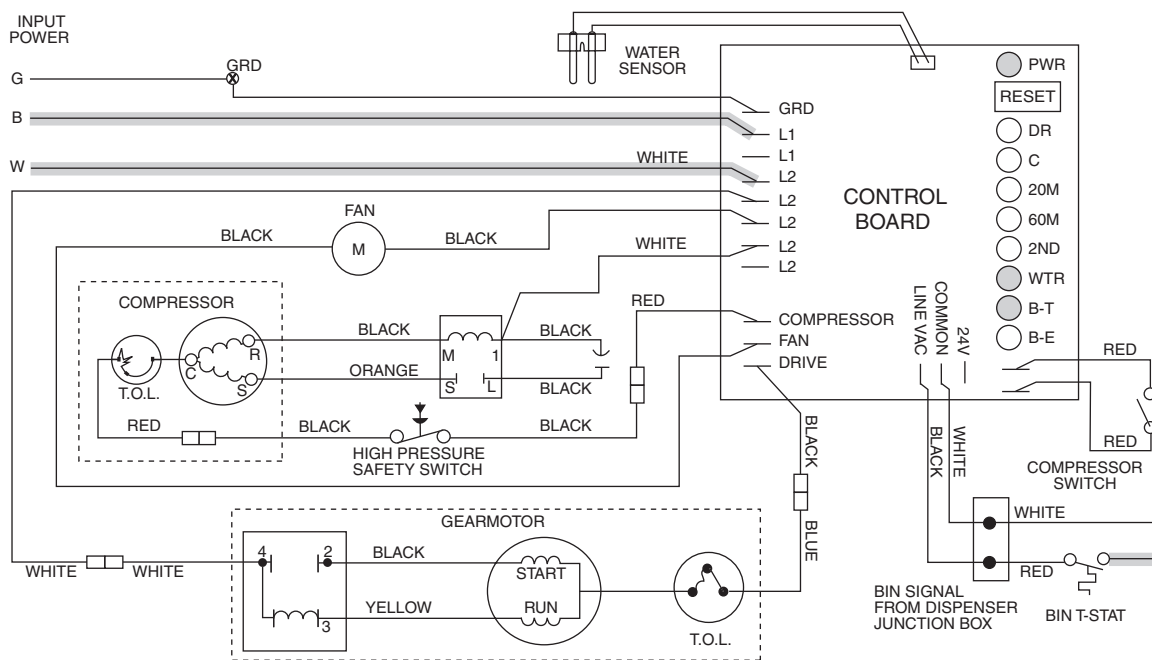
### Normal operation – Stage 4

Once the ice level control opens, the B-E LED goes out. After a 10 second delay the compressor LED (C), compressor and fan motor go off. (Should the ice level control not remain open for 10 seconds, the icemaker will continue to run.) The gearmotor continues to run and the DR LED remains lighted for 60 seconds. The purpose of this function is to drive the remaining ice out of the evaporator and to boil off any refrigerant remaining in the evaporator. The bin timer LED (BT) comes on, starting the twenty minute off cycle time delay.



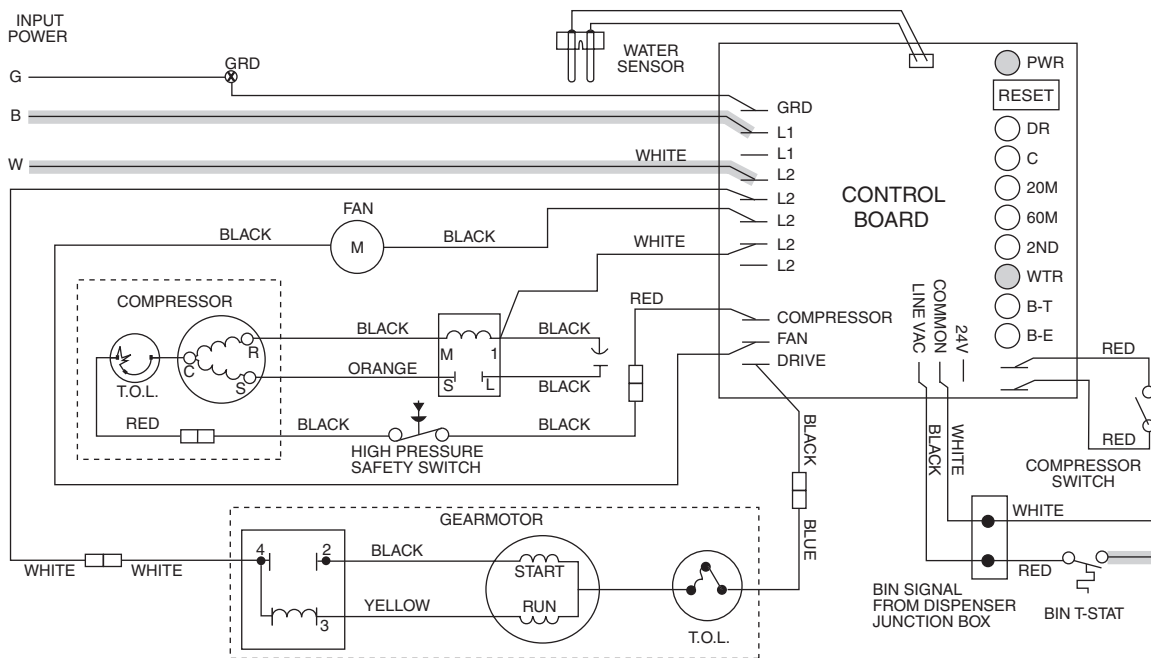
### Normal operation – Stage 5

The drive motor now shuts down and the DR LED is off. The B-T LED remains on for 20 minutes. The icemaker will not start while the B-T LED is on. To restart the icemaker for troubleshooting purposes, depress the reset button to clear the control board.



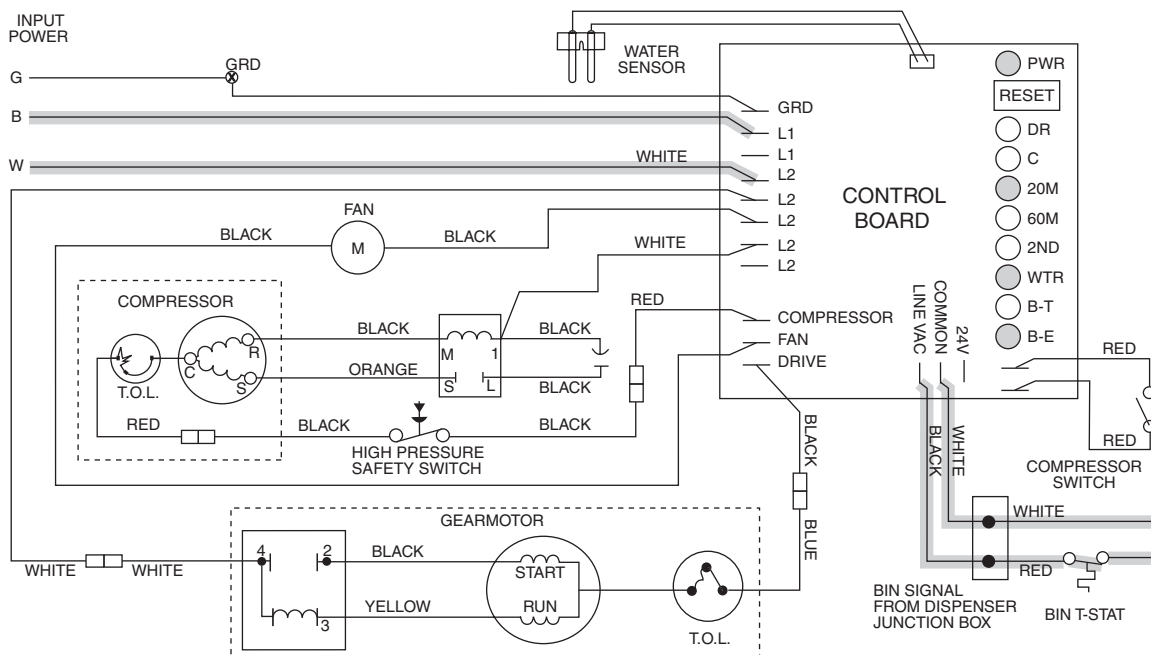
## Normal operation – Stage 6

When the dwell time of 20 minutes has expired, the B-T LED goes off. The icemaker goes through the normal start-up sequence when the bin level control signals the control board for ice. The WTR LED will remain on as long as the water sensor in the float reservoir senses water.



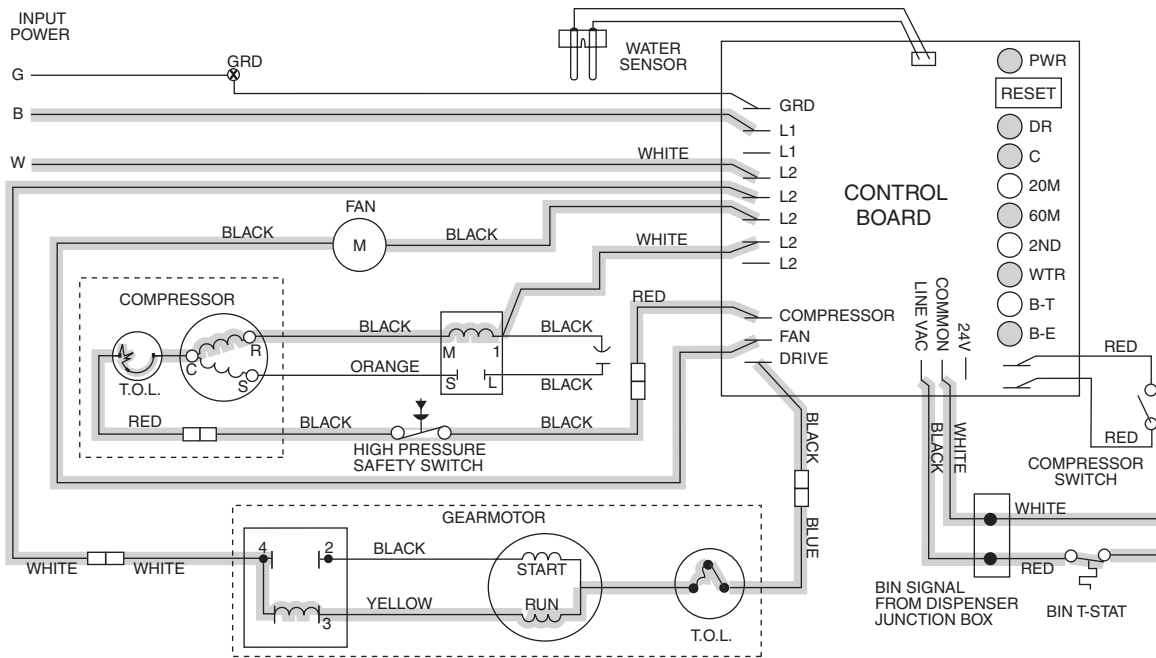
## Diagnostic sequence – Stage 7

The 20 minute error LED (20M) is on, indicating that the control board has sensed an over-torque condition (above 3 AMPS on the gearmotor). The 20M LED remains on for 20 minutes after an over-torque condition has occurred. The icemaker remains off as long as the 20M LED is on. When the 20M LED goes off, the control board will try to go through a normal start-up sequence. The WTR LED remains on as long as the water sensor in the float reservoir senses water.



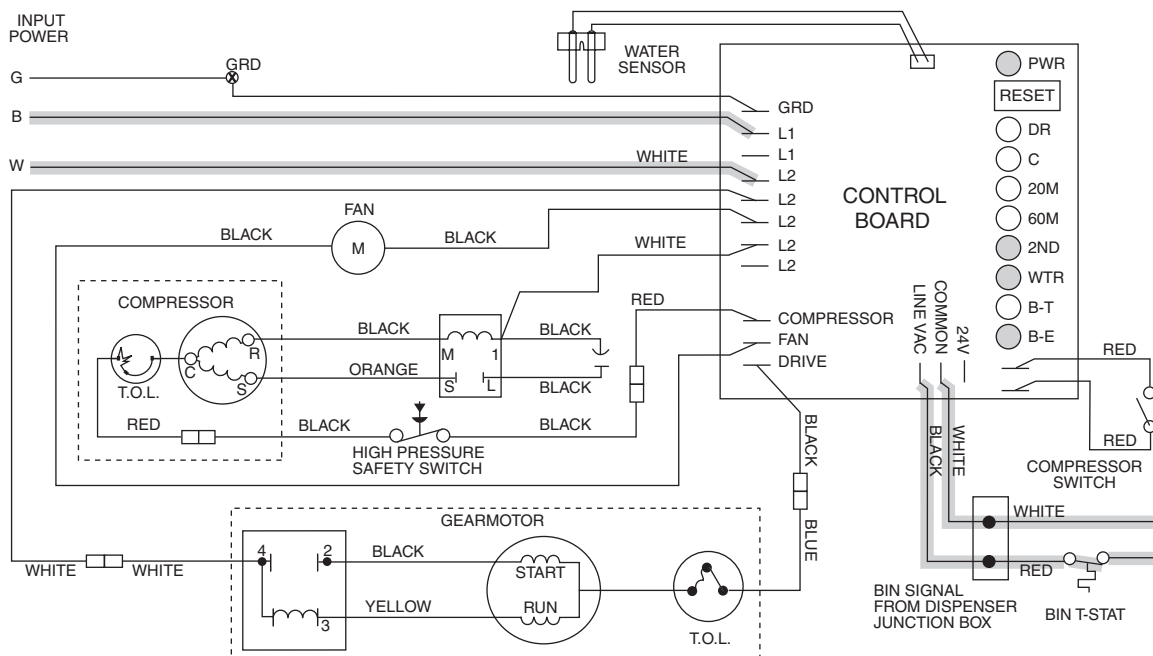
### Diagnostic sequence – Stage 8

If the restart is successful the 20M LED goes off, the 60 minute timer LED (60M) comes on. The 60M LED remains on for 60 minutes from restart. A lighted 60M LED indicates that the icemaker has experienced an over-torque condition. If the icemaker runs without problems for 60 minutes and no additional torque errors occur, the 60M LED goes off and the icemaker continues normal operation.



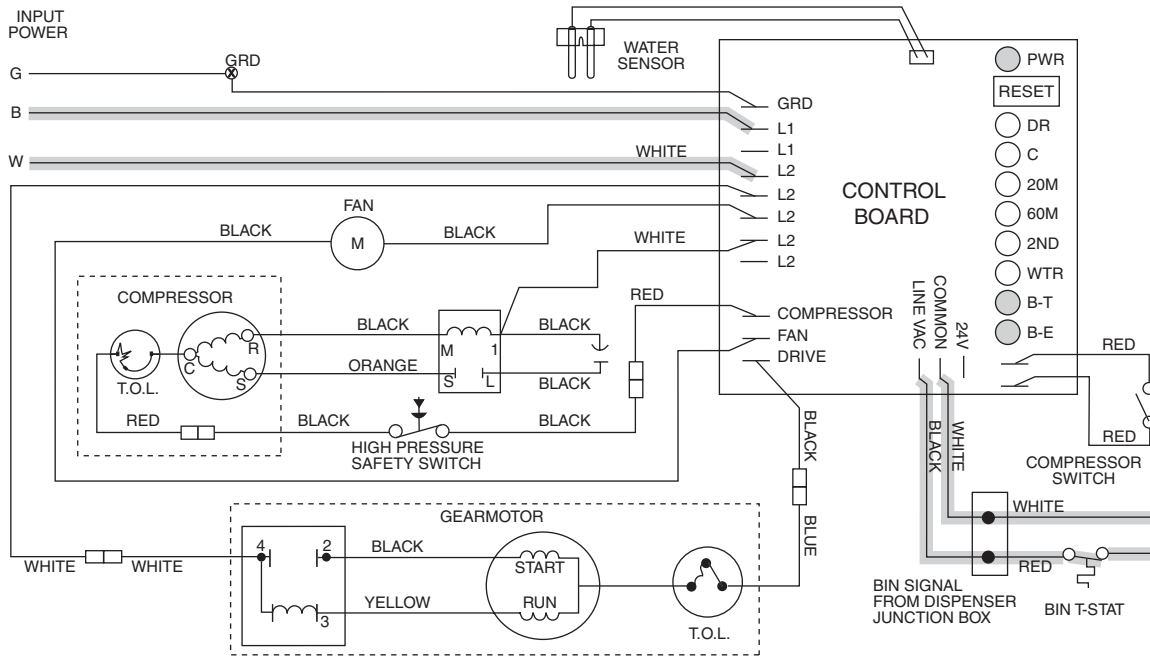
### Diagnostic sequence – Stage 9

The second error (2ND) LED comes on if an over-torque condition occurs while the 60M LED is still lighted. The 2ND LED indicates that two consecutive over-torque situations have occurred. The icemaker will be shut down at this time and will not restart unless the manual reset button is depressed.

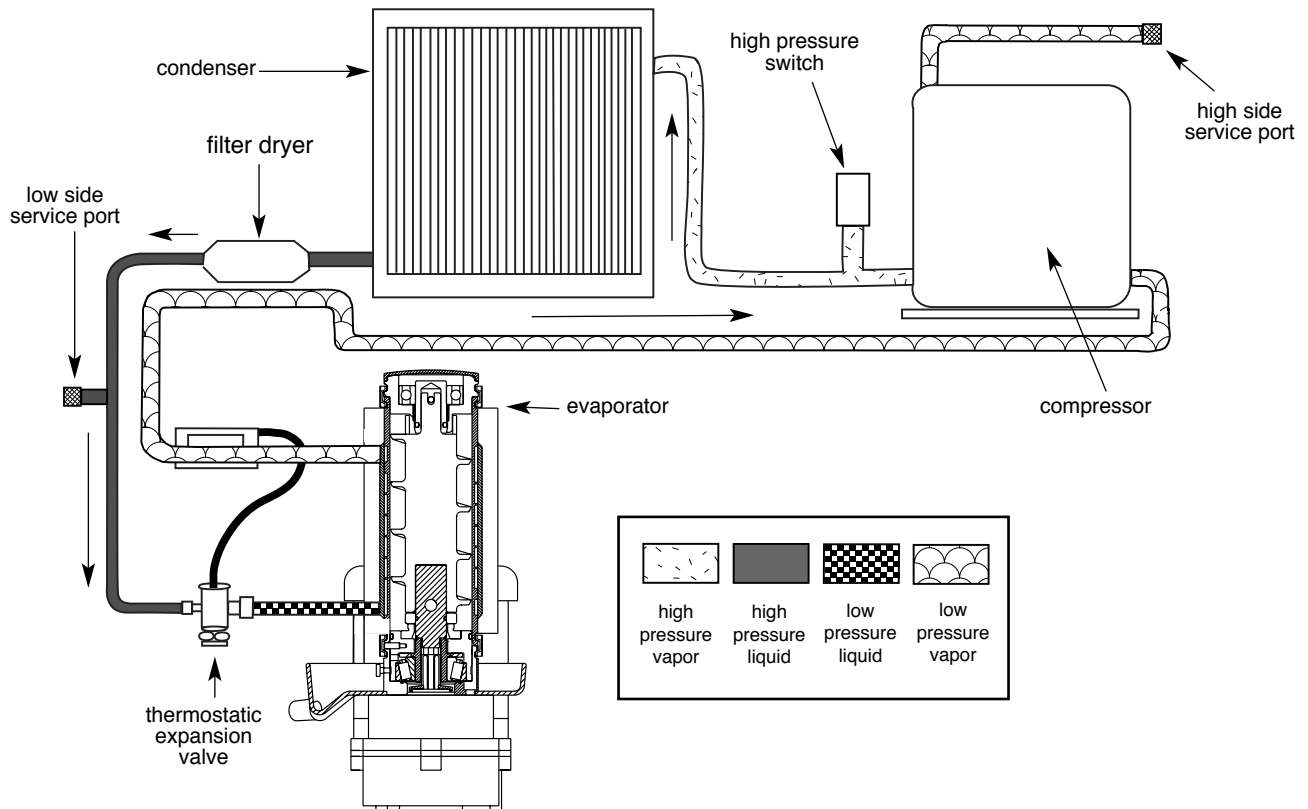


### Diagnostic sequence – Stage 10

If the water level in the float reservoir drops to an unacceptable level, the WTR LED goes out, shutting the icemaker off. Also, the BT LED comes on, preventing the icemaker from restarting for twenty minutes. If water is restored, the WTR LED comes back on and flashes to alert the technician that water to icemaker has been lost. The icemaker restarts at the end of the 20 minute time delay. The flashing WTR LED can be cleared by pressing the reset button.



### Refrigeration cycle



## Refrigeration pressure data

Air-cooled icemaker capacity/24 hrs.  
Ambient Air Temperature °F/°C

Inlet Water Temperature °F/°C	F	60	70	80	90	100	
	C	16	21	27	32	38	
50	468	417	366	317	268	219	lbs.
10	212	189	166	144	122	100	kg.
60	450	402	354	298	243	188	lbs.
16	204	182	161	135	110	90	kg.
70	432	387	342	280	217	166	lbs.
21	196	176	155	127	98	79	kg.
80	410	369	328	271	214	157	lbs.
27	186	175	149	123	97	77	kg.
90	387	351	314	262	210	158	lbs.
32	176	159	142	119	95	76	kg.

Air-cooled Icemaker  
Refrigeration Pressure  
Discharge Pressure/Suction Pressure

Ambient air temperature °F/°C	Ambient air temperature °F/°C			
	°F/°C	60/16	80/27	100/38
50/10	174/23	245/31	237/37	psi
70/21	174/23	244/30	326/38	psi
90/32	190/25	265/32	347/40	psi

<b>Table 2 – Compressor data</b>					
<b>Compressor current draw</b>					
<b>Air-cooled</b>					
Ambient air temp.	60°F/15.6°C	70°F/21.1°C	80°F/26.7°C	90°F/32.2°C	100°F/37.8°C
	6.3A	6.5A	6.7A	6.9A	7.1A
<b>Locked rotor amps</b>	58.8				

<b>Table 3 – Gearmotor data</b>	
Gearmotor current	2.25A (nominal)
Locked rotor amps	14 amps

## Refrigeration system

**Important:** All service on refrigeration system must be performed in accordance with all federal, state and local laws that pertain to the use of refrigerants. It is the responsibility of the technician to ensure that these requirements are met.

<b>R400 icemaker charge specifications</b>		
<b>Model</b>	<b>Charge</b>	<b>Refrigerant type</b>
12CI400A, 12HI400A (air-cooled)	19 oz	R404A



**Recharging of unit at other than factory specifications will void icemaker warranty.**

### Refrigerant replacement requirements

1. Non-contaminated refrigerant removed from any Follett refrigeration system can be recycled and returned to the same system after completing repairs. Recycled refrigerant must be stored in a clean, approved storage container. If additional refrigerant is required, virgin or reclaimed refrigerant that meets ARI standard 700-88 must be used.
2. In the event of system contamination (for example, a compressor burn out, refrigerant leak, presence of non-condensibles or moisture), the system must be repaired, evacuated and recharged using virgin or reclaimed refrigerant that meets ARI standard 700-88.
3. Follett Corporation does not approve of recovered refrigerants. Improper refrigeration servicing procedures will void the factory warranty.

### Evacuation

Evacuate the system to a level of 500 microns. When the 500 micron level is reached, close valves and both manifold and shut down the vacuum pump. Allow the system to sit for approximately 20 minutes. During this period the system pressure should not rise. If the system pressure rises and stabilizes there is moisture in the system and further evacuation is needed. If the pressure continues to rise check the system for leaks.

<b>Ambients</b>	<b>Minimum</b>	<b>Maximum</b>
Air temperature <sup>1</sup>	50°F/10°C	100°F/37.8°C
Water temperature <sup>2</sup>	40°F/4.4°C	90°F/32.2°C

<sup>1</sup>Ambient air temperature is measured at the air-cooled condenser coil inlet.

<sup>2</sup>Ambient water temperature is measured in the icemaker float reservoir.

## Ice capacity test

Icemaker production capacity can only be determined by weighing ice produced in a specific time period.

1. Remove top panel and hopper lid of unit.
2. Weigh and record weight of container used to catch ice.
3. Run icemaker for at least 15 minutes.
4. Catch ice for 15 or 20 minutes.
5. Weigh harvested ice and record total weight.
6. Subtract weight of container from total weight.
7. Convert fractions of pounds to decimal equivalents (Ex. 6 lbs 8 oz = 6.5 lbs).
8. Calculate production using following formula:

$\frac{1440 \text{ min.} \times \text{wt. of ice produced}}{\text{Total test time in minutes}} = \text{Production capacity/24 hr. period}$
--

9. Calculated amount per 24 hours should be checked against rated capacity for same ambient and water temperatures in Ice Production Table (see page 22).

## Dispenser troubleshooting



**Disconnect power to unit before putting hands or arms in storage area or attempting any repair or service to equipment.**

### Before calling for service

1. Check that no ice is in the dispenser bin area.
2. Check that congealed ice is not causing a jam
3. Check that all switches and circuit breakers are on
4. Check that all drains are clear.

## Troubleshooting the dispenser – lever models

Problem	Indicators	Corrective Action
Does not dispense ice.	<ol style="list-style-type: none"> <li>1. Power switch off or faulty.</li> <li>2. Faulty dispense switch.</li> <li>3. Wheel motor malfunction.</li> <li>4. Storage hopper cover (inside dispenser cabinet) off or ajar.</li> </ol>	<ol style="list-style-type: none"> <li>1. Check switch – turn on or replace if faulty.</li> <li>2. Replace switch.</li> <li>3. Check motor and capacitor and replace as required.</li> <li>4. Secure cover.</li> </ol>
Dispense wheel rotates continuously.	Dispense switch contacts burned shut.	Replace dispense switch.
Icemaker runs continuously.	Faulty or incorrectly positioned bin stat.	Check for proper positing – if stat does not open when ice is places on capillary tube, replace stat.
Does not dispense water.	<ol style="list-style-type: none"> <li>1. Faulty water solenoid valve.</li> <li>2. Faulty dispense switch.</li> <li>3. Power switch off or faulty.</li> </ol>	<ol style="list-style-type: none"> <li>1. Replace water solenoid valve.</li> <li>2. Replace dispense switch.</li> <li>3. Check switch – turn on or replace if faulty.</li> </ol>



## Troubleshooting the dispenser – SensorSAFE models

### Problem: Does not dispense ice and/or water

Action	LED status			Solution
	PWR	CLN	ICE/WTR	
Check LEDs on control board	OFF	OFF	OFF	Check circuit breakers and power switch. Restore power or replace defective switch.
	ON	ON	OFF	Press clean switch on lower left side of electrical enclosure to return board to normal operation.
Place cup under drop zone	ON	OFF	OFF	Troubleshoot appropriate lens/sensor and replace if required (see Lens/Sensor Troubleshooting).
	ON	OFF	ON	Verify power on appropriate output terminal (WTR or WM) on control board and replace board if required. If board tests okay, troubleshoot appropriate dispenser component.

### Problem: Dispenses ice and/or water continuously

Action	LED status			Solution
	PWR	CLN	ICE/WTR	
Check LEDs on control board	ON	OFF	ON	Troubleshoot appropriate lens/sensor and replace if required (see Lens/Sensor Troubleshooting).
	ON	OFF	OFF	If there is power on any output terminal (WTR or WM) on control board, replace board.

### Board guide

LEDs, when illuminated, indicate the following: PWR (board power), CLN (cleaning, no dispensing cycle), ICE (ice dispensing activated), WTR (water dispensing activated).

Terminals: L1 (incoming power, hot), L2 (neutral terminals), WTR (power terminal for water solenoid), WM (power terminal for wheelmotor), CLN (terminals for clean cycle switch).

**Note:** SOL terminal not used in 12 series dispensers.

### Lens/sensor troubleshooting

1. Turn dispenser power switch off and remove splash panel.
2. Disconnect wires from WTR and WM terminals on board.
3. Gently remove sensor/mounting block from splash panel.
4. Inspect lens and sensor, clean if necessary.
5. Restore dispenser power and test sensor by passing hand in front of sensor.
6. If LED on board turns on, sensor is operational. Re-assemble dispenser.
7. If LED does not come on switch sensor leads on board and retest.
8. If opposite Led comes on – replace defective board.
9. If opposite Led does not come on – replace defective sensor.

## Icemaker troubleshooting chart

Flashing water LED at any time indicates that water signal to board had been lost for more than one second.

Ten-second delay: There is a 10 second delay in reaction to loss of water (WTR) or bin (B-E) signals. If signals are not lost for more than 10 seconds, no reaction will occur.

Problem	Indicators/possible cause	Corrective action
1. Icemaker will not run. <b>System status:</b> compressor, gearmotor, and fan motor inoperative.	1. No power to unit. 2. Open bin level control. 3. Water OK LED (WTR) not on. 4. 20M or 2ND LED is on indicating that first or second torque error has occurred. 5. Gear motor locked up (immediate torque error indicated by LEDs when board is reset). 6. Open coil on gearmotor start relay causing an immediate torque error.	1. Check that unit is plugged in, circuit breakers are on. 2. Adjust or replace ice level control. 3. Check reservoir for water, restore water to unit. 4. See #6 below. 5. Repair or replace gearmotor. 6. Replace gearmotor start relay.
2. Compressor will not run. <b>System status:</b> gearmotor and fan motor run.	1. Condenser coil plugged causing open overload or high pressure cut-out. 2. Defective starting capacitor. 3. Defective starting relay. 4. Open motor winding. 5. No power output from compressor output terminal on control board.	1. Clean condenser coil and replace overload if necessary. 2. Replace start capacitor. 3. Replace relay. 4. Ohm out windings and replace compressor if necessary. 5. Check terminal connection and replace control board if necessary.
3. Unit cycles intermittently. <b>System status:</b> compressor, gearmotor, and fan motor cycle.	1. Float reservoir running dry, sensing probe signalling for system to shut down.	1. Check water supply to float and float operation. PC board will have flashing WTR LED.
4. Low ice production. Poor quality ice.	1. Dirty condenser coil. 2. Restricted air flow to condenser coil. 3. Mineral coated evaporator. 4. Improper exhaust air provisions. 5. Faulty expansion valve. 6. Low refrigerant charge. 7. Superheat incorrect. 8. Inefficient compressor.	1. Clean condenser. 2. Remove obstruction. 3. Clean evaporator. 4. Provide proper exhaust air provisions per Follett installation manual. 5. Replace expansion valve. 6. Check for leaks; repair, evacuate, and weigh in correct charge. 7. Check that TEV sensing bulb is securely clamped in place and not damaged; check that insulated bulb cover is in place. 8. Replace compressor.
5. Water leaks from bottom of evaporator.	1. O ring seal broken.	1. Replace O ring.

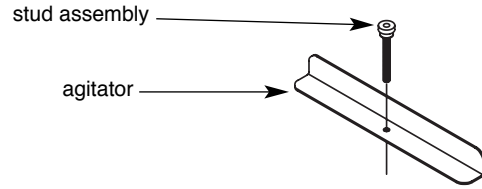
## Icemaker troubleshooting chart

Problem	Indicators/possible cause	Corrective action
<p>6. Icemaker runs for short period of time and shuts down on torque error. <b>System status:</b> 20M or 2nd LED are lit.</p>	<ol style="list-style-type: none"> <li>1. Kink in ice transport tube.</li> <li>2. Bin level control remains in closed position.</li> <li>3. Ice transport tube ruptured internally.</li> <li>4. Worn evaporator bearings.</li> <li>5. Faulty gearmotor start relay. Icemaker torques out within 5 seconds of start-up.</li> <li>6. Torque out occurs when storage bin fills to capacity.</li> </ol>	<ol style="list-style-type: none"> <li>1. Eliminate kink and check that tube routing complies with Follett icemaker installation manual.</li> <li>2. Adjust or replace control.</li> <li>3. Replace complete run of ice transport tube.</li> <li>4. Inspect bearings for roughness or binding and replace if necessary.</li> <li>5. Replace gearmotor start relay.</li> <li>6. Ensure that ice contacts bin thermostat before backing ice up in transport tube. Refer to dispenser manual for proper thermostat and ice tube mounting.</li> </ol>
<p>7. Evaporator is iced up on the outside. No ice production. <b>System status:</b> compressor, gearmotor and fan motor running.</p>	<ol style="list-style-type: none"> <li>1. Gearmotor running but no output rotation.</li> <li>2. Float reservoir empty.</li> <li>3. Air bubble in water supply line. Water in reservoir but not in evaporator.</li> </ol>	<ol style="list-style-type: none"> <li>1. Check for broken gearmotor output shaft or damaged gearbox.</li> <li>2. Check for defective water sensor (water OK (WTR) LED remains on even when float empty or probe removed from water).</li> <li>3. Purge air from line.</li> </ol>
<p>8. Compressor cycles intermittently. <b>System status:</b> gearmotor and fan motor run.</p>	<ol style="list-style-type: none"> <li>1. Compressor start relay in wrong position.</li> <li>2. High pressure cutout open due to high head pressure.</li> <li>3. Clogged or dirty condenser coil.</li> <li>4. Improper ventilation.</li> <li>5. Defective compressor.</li> </ol>	<ol style="list-style-type: none"> <li>1. Position relay with arrow or word "top".</li> <li>2. Check discharge pressure and adjust water regulator valve.</li> <li>3. Clean condenser coil.</li> <li>4. Provide inlet and exhaust air provisions per Follett icemaker installation manual.</li> <li>5. Replace compressor.</li> </ol>
<p>9. Unit runs but not making ice. <b>System status:</b> compressor, gearmotor &amp; fan motor running.</p>	<ol style="list-style-type: none"> <li>1. Clogged or dirty condenser coil.</li> <li>2. Compressor not pumping.</li> <li>3. Low refrigerant charge.</li> </ol>	<ol style="list-style-type: none"> <li>1. Clean condenser coil.</li> <li>2. Replace compressor.</li> <li>3. Check for leaks; repair, evacuate, and weigh in correct charge.</li> </ol>
<p>10. Compressor and fan motor will not run. Gearmotor runs.</p>	<ol style="list-style-type: none"> <li>1. Compressor switch in OFF position.</li> <li>2. No output on compressor and fan motor terminals on control board.</li> <li>3. Failed fan motor causes high pressure cut-out to open.</li> </ol>	<ol style="list-style-type: none"> <li>1. Turn compressor switch on.</li> <li>2. Replace control board.</li> <li>3. Replace fan motor.</li> </ol>
<p>11. Intermittent noises from evaporator.</p>	<ol style="list-style-type: none"> <li>1. Mineral build-up on evaporator surface.</li> </ol>	<ol style="list-style-type: none"> <li>1. Clean evaporator with liquid icemaker cleaner.</li> </ol>

# Disassembly and replacement instructions

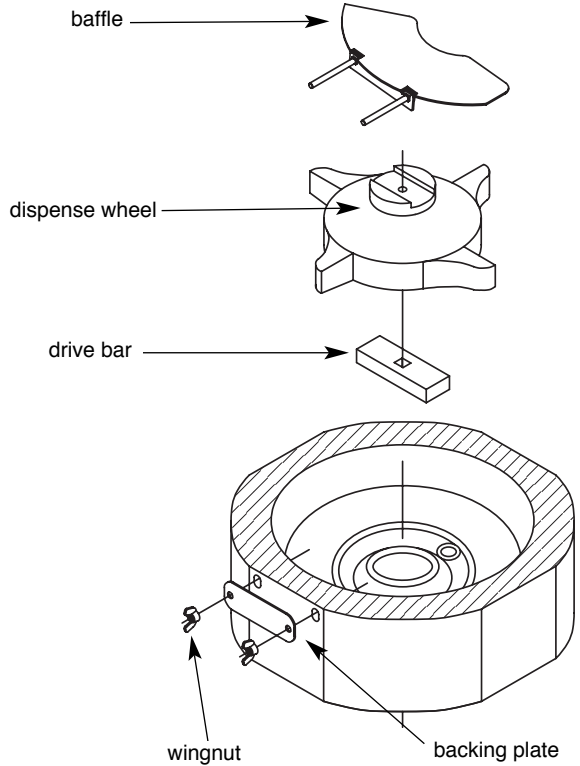
## Dispense chute removal

1. Remove top cover (see page 30).
2. Remove stainless front cover (see page 30).
3. Slide plastic dispense chute cover up and out to remove.
4. Remove four (4) push fasteners holding dispense tube in place and remove tube.



## Dispense wheel and drive bar removal

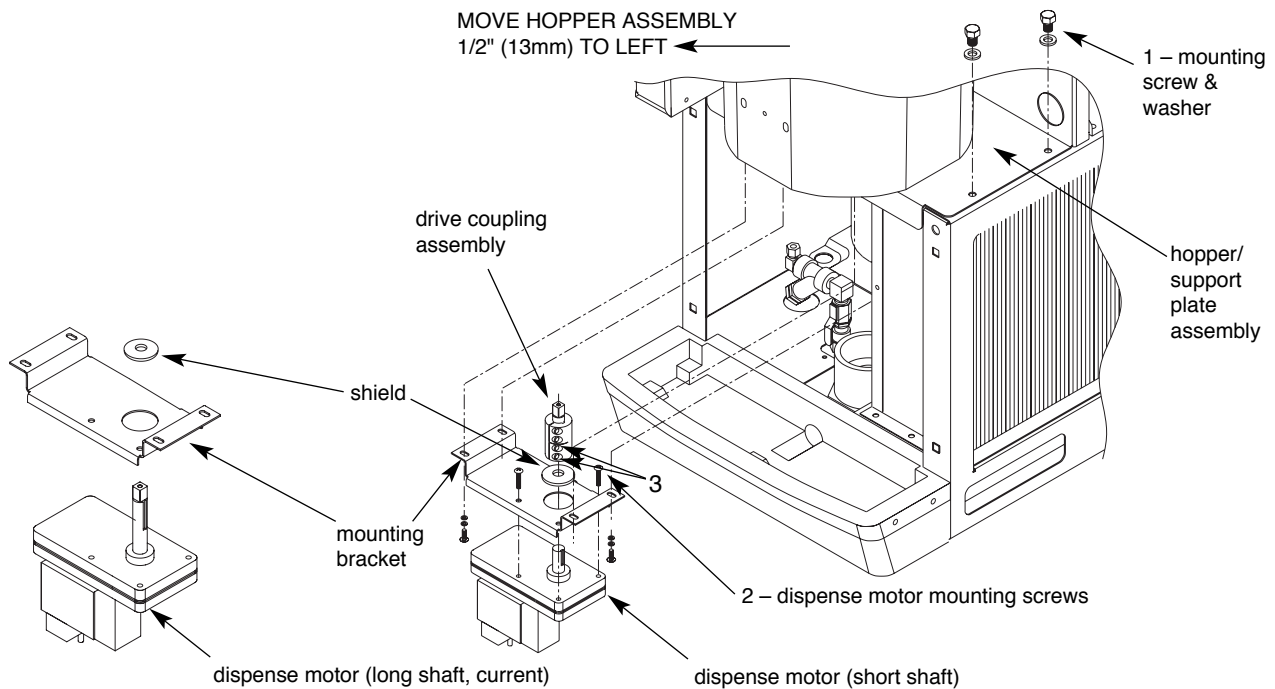
1. Remove all ice from storage area of dispenser.
2. Remove center thumbscrew, locking plate, two wingnuts and backing plate from front of storage hopper (see drawing at right).
3. Remove stud assembly, agitator, spacer, baffle, wheel and drive bar in this sequence.



## Wheelmotor removal

1. Remove dispense wheel and drive bar (see above).
2. Remove four (4) hopper/support plate mounting screws and washers (Fig. 11.1).
3. Move hopper assembly 1/2" (13mm) to left.
4. Remove four (4) dispenser motor bracket mounting screws and washers (Fig. 11.2).
5. **Short shaft motors only:** loosen **only** two (2) lower screws on drive coupling and remove from motor shaft (Fig. 11.3).
6. Remove four (4) screws holding motor to mounting bracket.

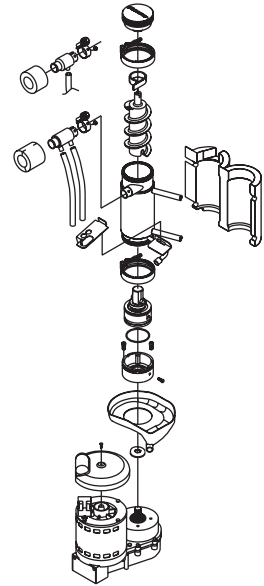
Fig. 11



## Evaporator disassembly

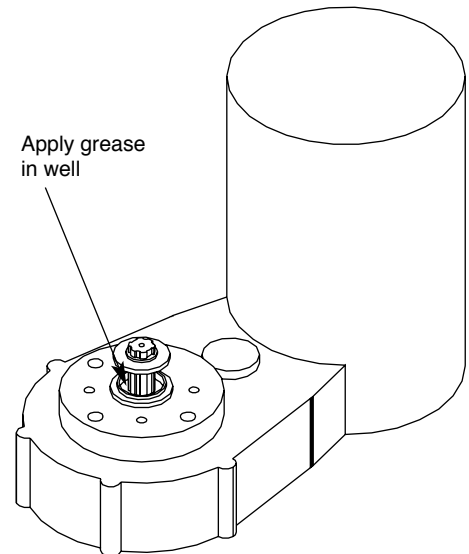
**Note:** The upper bearing, lower bearing and auger assemblies must be replaced as assemblies. The bottom and top bearing assemblies cannot be field assembled to factory specifications.

1. Disconnect power to icemaker.
2. Shut off water to icemaker.
3. Drain evaporator and float tank.
4. Disconnect plastic tubing from evaporator water inlet, drain pan stub, compression nozzle tubing and reservoir overflow tubing from secured clip.
5. Disconnect ice transport tube from compression nozzle.
6. Remove nut and upper vee band coupling from top of evaporator
7. Lift top bearing assembly straight up with a slight rotating motion and remove.
8. Remove ice compression loop located at top of auger.
9. Lift auger straight up and out of evaporator.
10. Remove nut and lower vee band coupling from bottom of evaporator.
11. Lift evaporator to clear bottom bearing assembly.
12. Loosen hex head bolt in side of mounting base with 5/16 wrench and lift lower bearing assembly.
13. Remove condensate shield.
14. Remove 4 Allen head machine screws holding mounting base to gearbox.
15. If replacing evaporator, remove compression nozzle from evaporator port.



## Evaporator reassembly

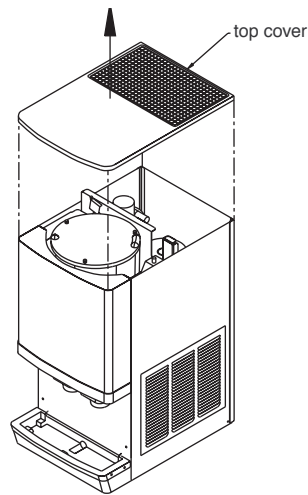
1. Clean gearmotor boss, output shaft and shaft well.
2. Install drain pan and evaporator mounting base.
3. Fill gear motor shaft well with food grade grease.
4. Install condensate shield and seat against gear motor boss.
5. Install bearing O ring in groove in evaporator mounting base.
6. Lower bottom bearing assembly into evaporator mounting base.
7. While maintaining a slight downward pressure on bottom bearing assembly, tighten hex head bolt with a 5/16 wrench.
8. Position evaporator over lower bearing assembly and align grooves with pins in bearing assembly.
9. **Install vee band clamp and nut to 70 in/lb.**
10. Place auger in center of evaporator and rotate to mate with drive pin.
11. Install ice compression loop, orienting loop.
12. Install upper bearing and seal assembly, rotating bearing to slip pin into auger slot.
13. **Install upper vee band clamp and nut to 70 in/lb.**
14. If evaporator was replaced, reinstall compression nozzle on new.



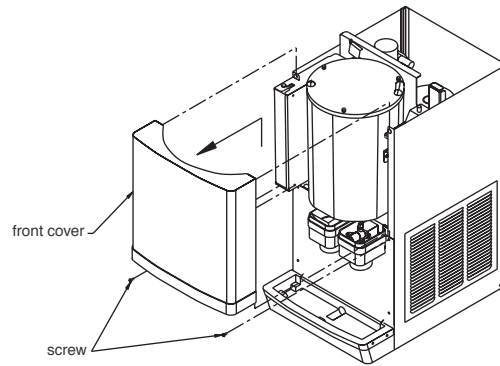
## Gearmotor replacement

1. Disassemble evaporator as described above.
2. Disconnect the wire connectors.
3. Remove 4 screws holding gear motor mounting plate to base of icemaker and lift gearbox and motor clear of icemaker.
4. Remove machine screws holding mounting plate to motor.
5. Install new motor in reverse order.

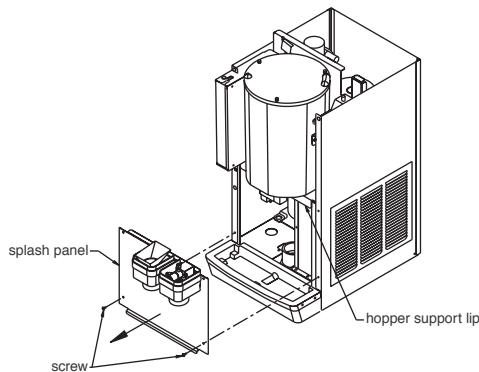
## Panel removal



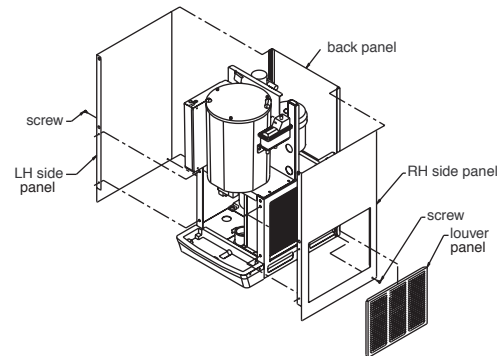
**Top cover:** Lift cover up and off Velcro strips.



**Front cover:** Remove 2 screws. Lift cover up and forward to unhook from keyhole slots and clear tabs on bottom of cover.

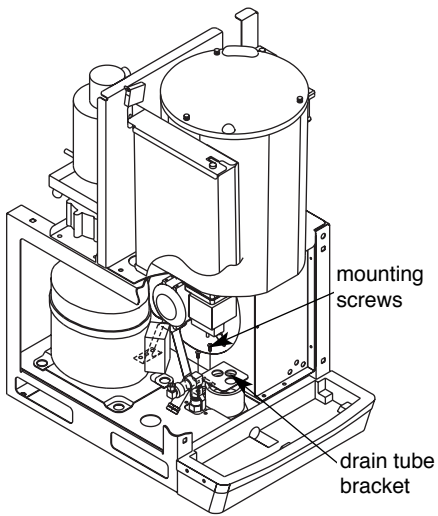


**Splash panel:** Remove 2 screws. Pull out bottom of panel to allow top to slide out from under hopper support lip.

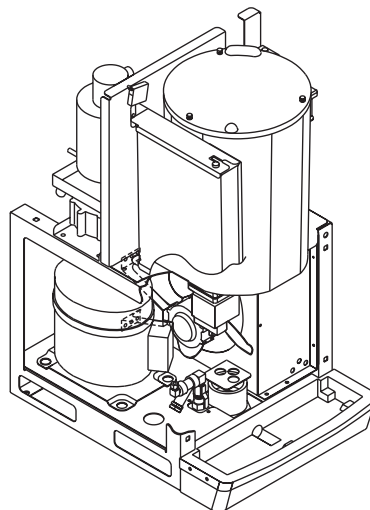


**Side panels:** Remove screw located on lower rear side. Pull side panel toward front of unit and out of back panel. Note: Before removing right hand side, remove side louver panel by lifting up and pulling forward on panel.

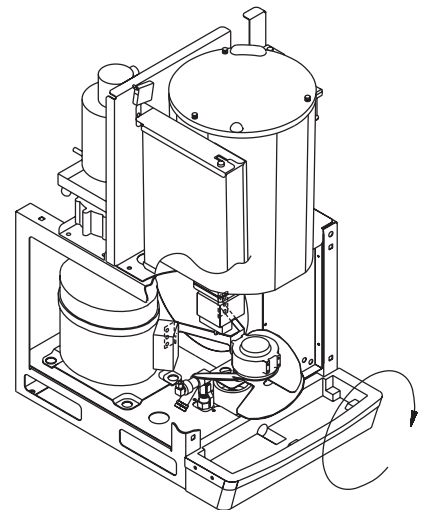
## Fan removal



(a) Remove 4 fan mounting screws and 3 drain tubes from bracket.

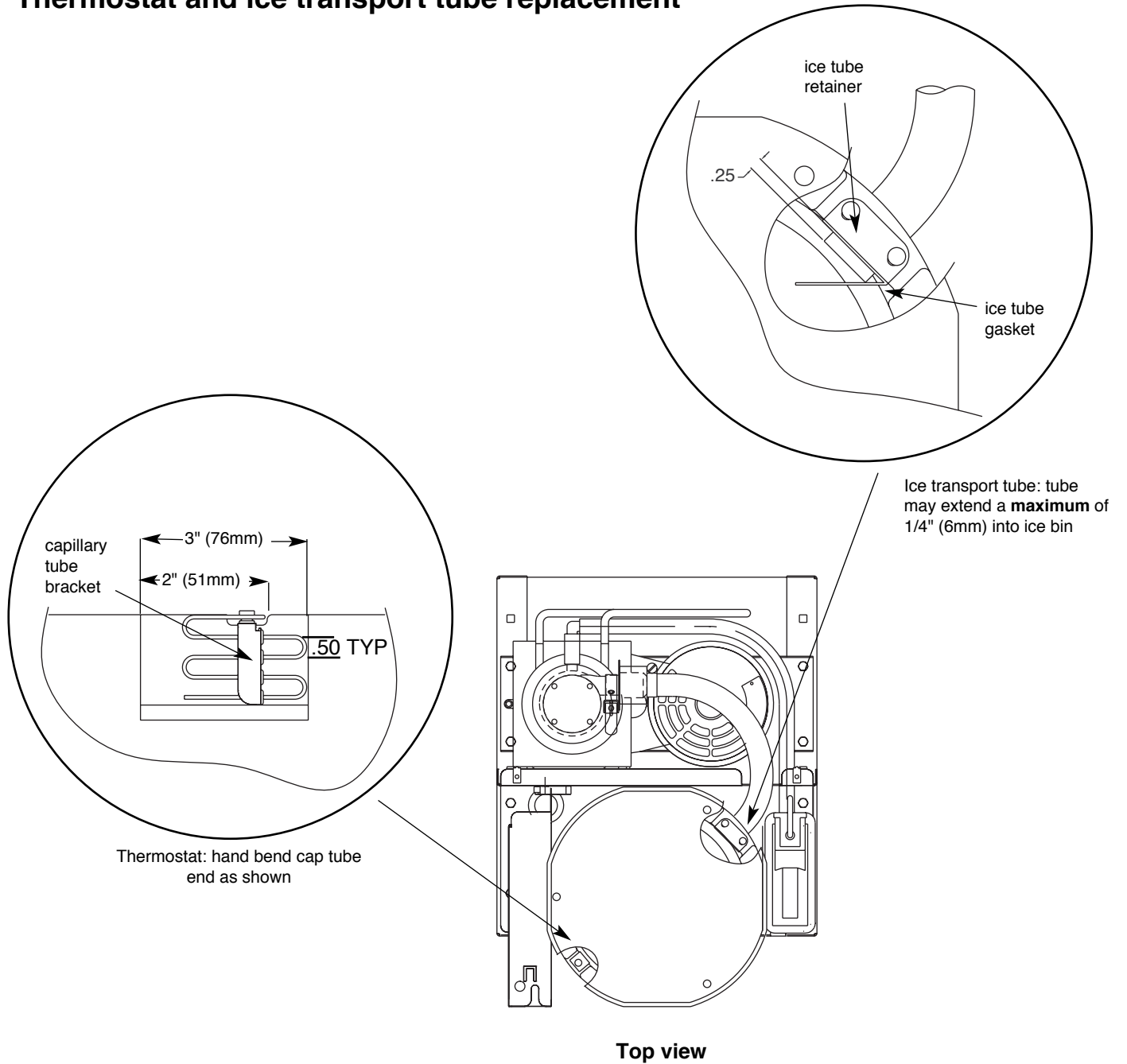


(b) Rotate fan mounting bracket toward back of unit and pull fan assembly toward front of unit.



(c) As fan assembly is being pulled toward front, rotate assembly clockwise as shown above.

# Thermostat and ice transport tube replacement

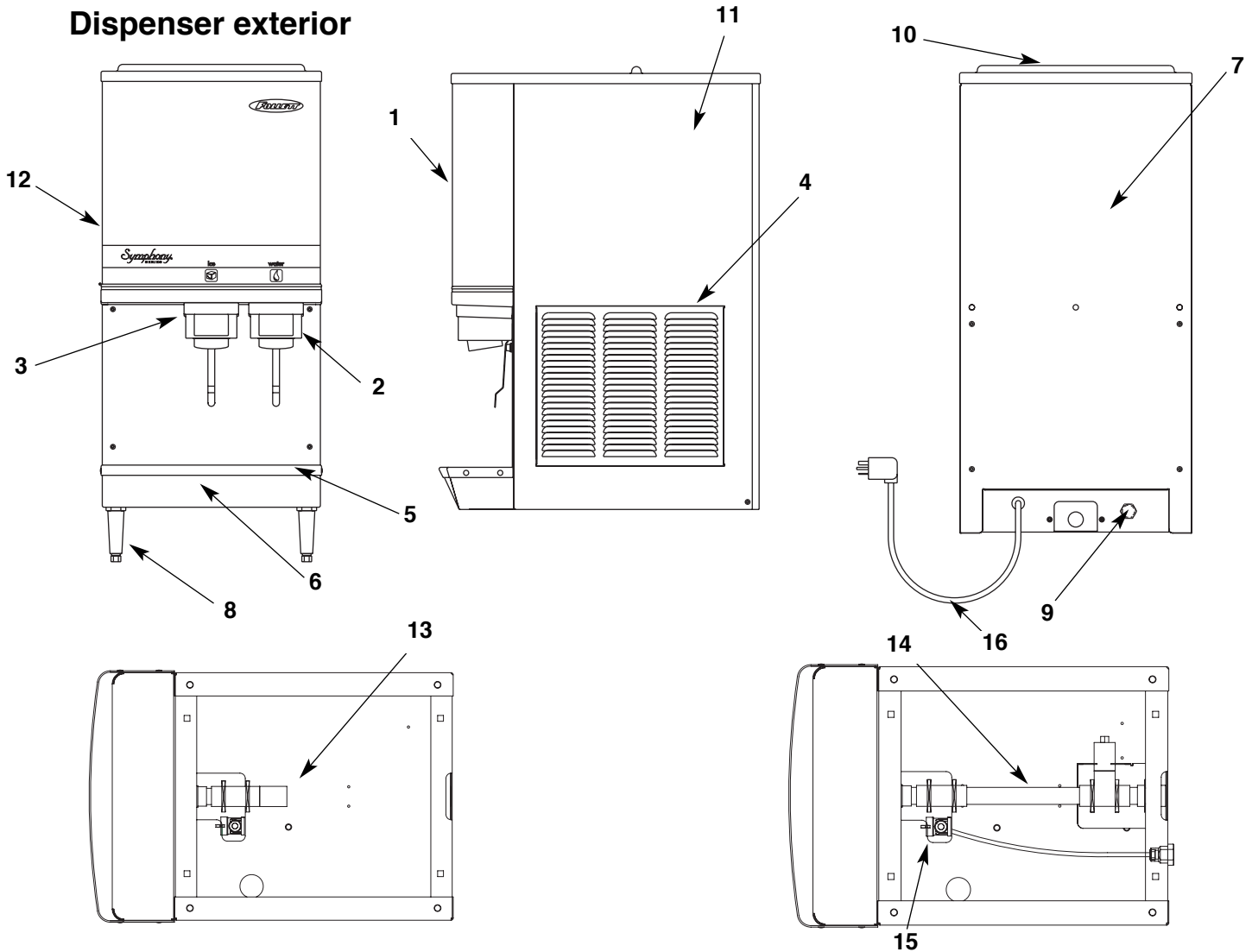


## Ice transport tube replacement

1. Push tube onto evaporator port.
2. Position clamp behind lip on evaporator port and tighten clamp.

# Replacement parts

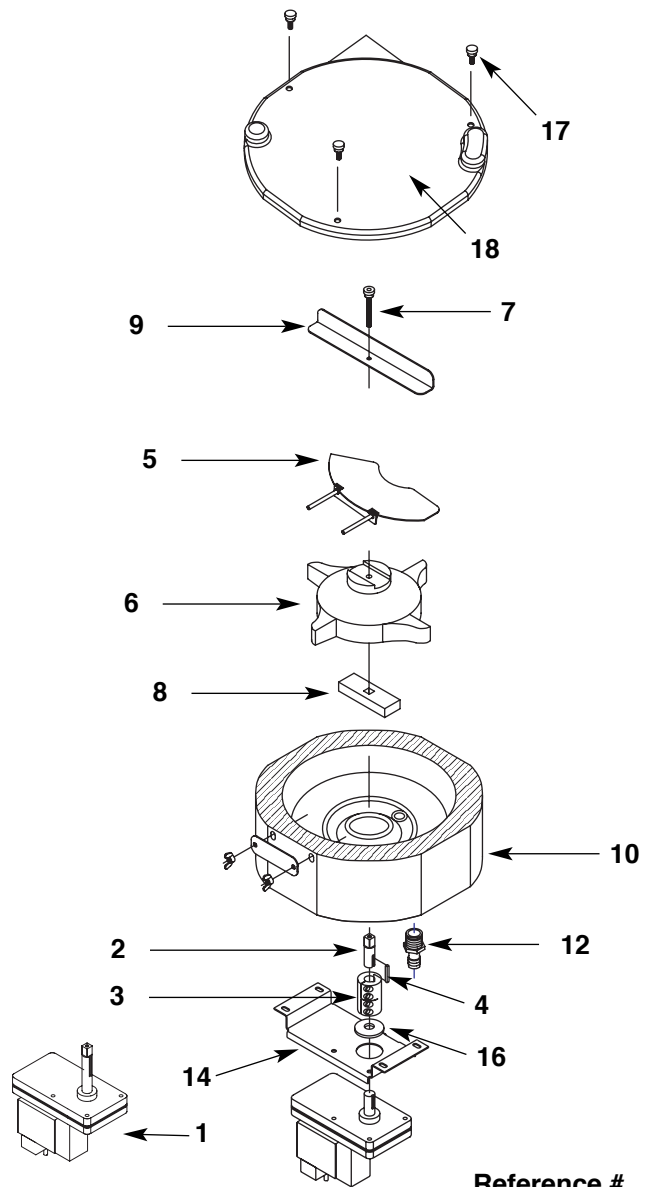
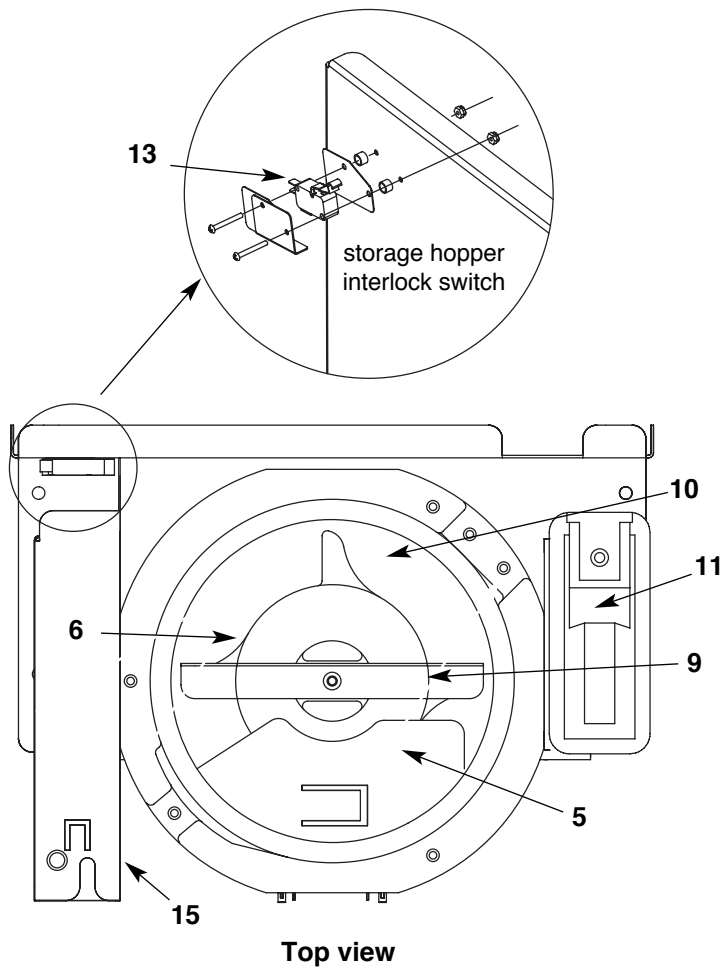
## Dispenser exterior



Part #	Description	Reference #
502818	Cover, front	1
502819	Cover, dispense assembly	2
502400	Cover, dispense assembly, ice	3
502402	Louver, intake	4
502412	Grille, drain pan	Not shown
502883	Drain pan, plastic	5
502410	Drain pan assembly (includes base, pan and grille)	6
502394	Panel, rear	7
502399	Leg kit, 4" (102mm), adjustable – set of 4	8
502415	Fitting, water inlet, brass	Not shown
502924	Fitting, water inlet, plastic	Not shown
00137315	Fitting, water inlet, brass 3/8" FPT	9
502884	Lid, top panel, plastic	10
502396	Panel, right side	11
502395	Panel, left side	12
502422	Drain tube assembly, wall mount w/drain pan	13
502391	Drain tube assembly, countertop	14
502925	Elbow, water, 3/8" (10mm)	15
502514	Drain tube assembly, wall mount w/o drain pan	Not shown
502873	Bracket, wall 16" (406mm)	Not shown
502776	Cord and plug, power	16

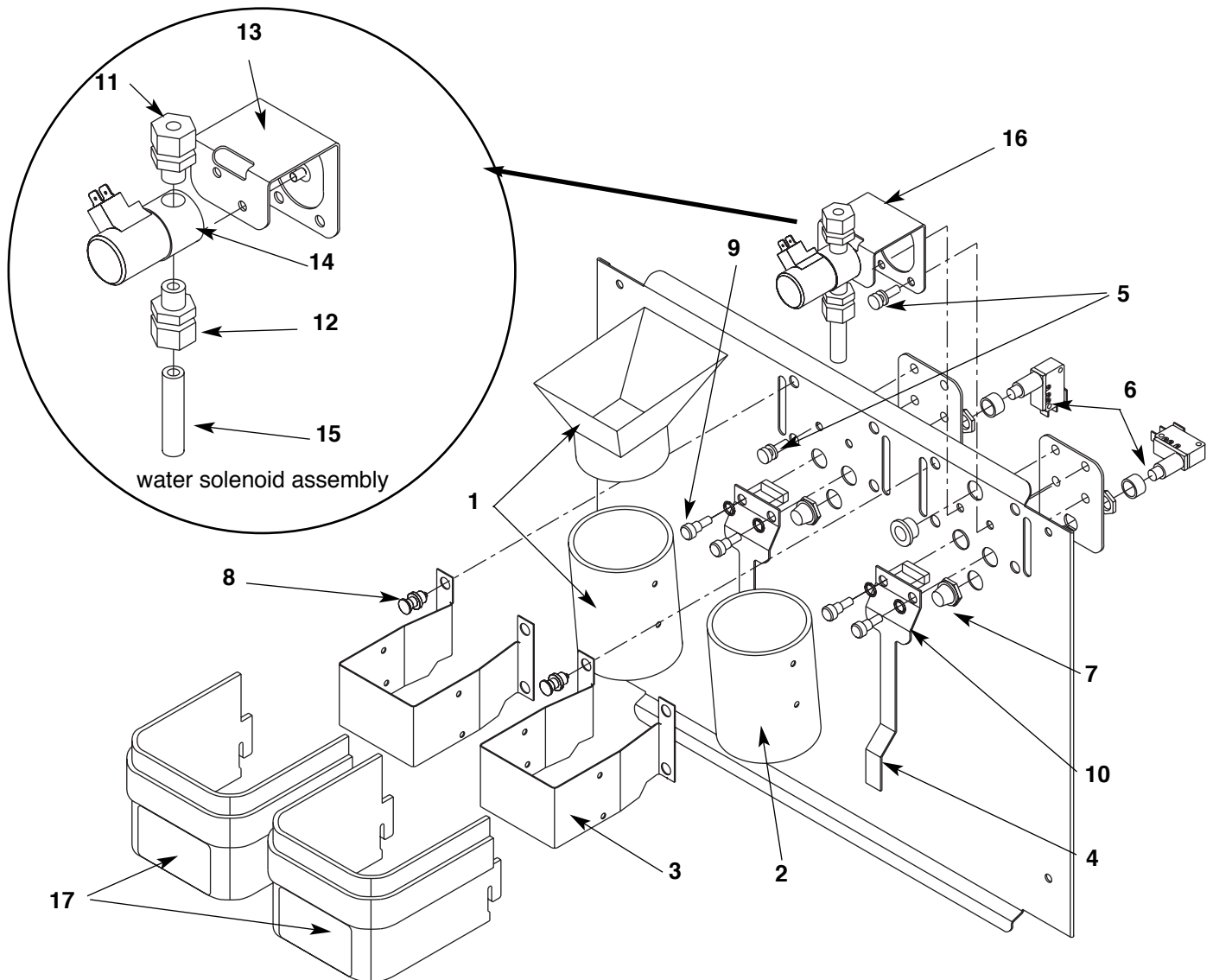


# Wheelmotor and drive system



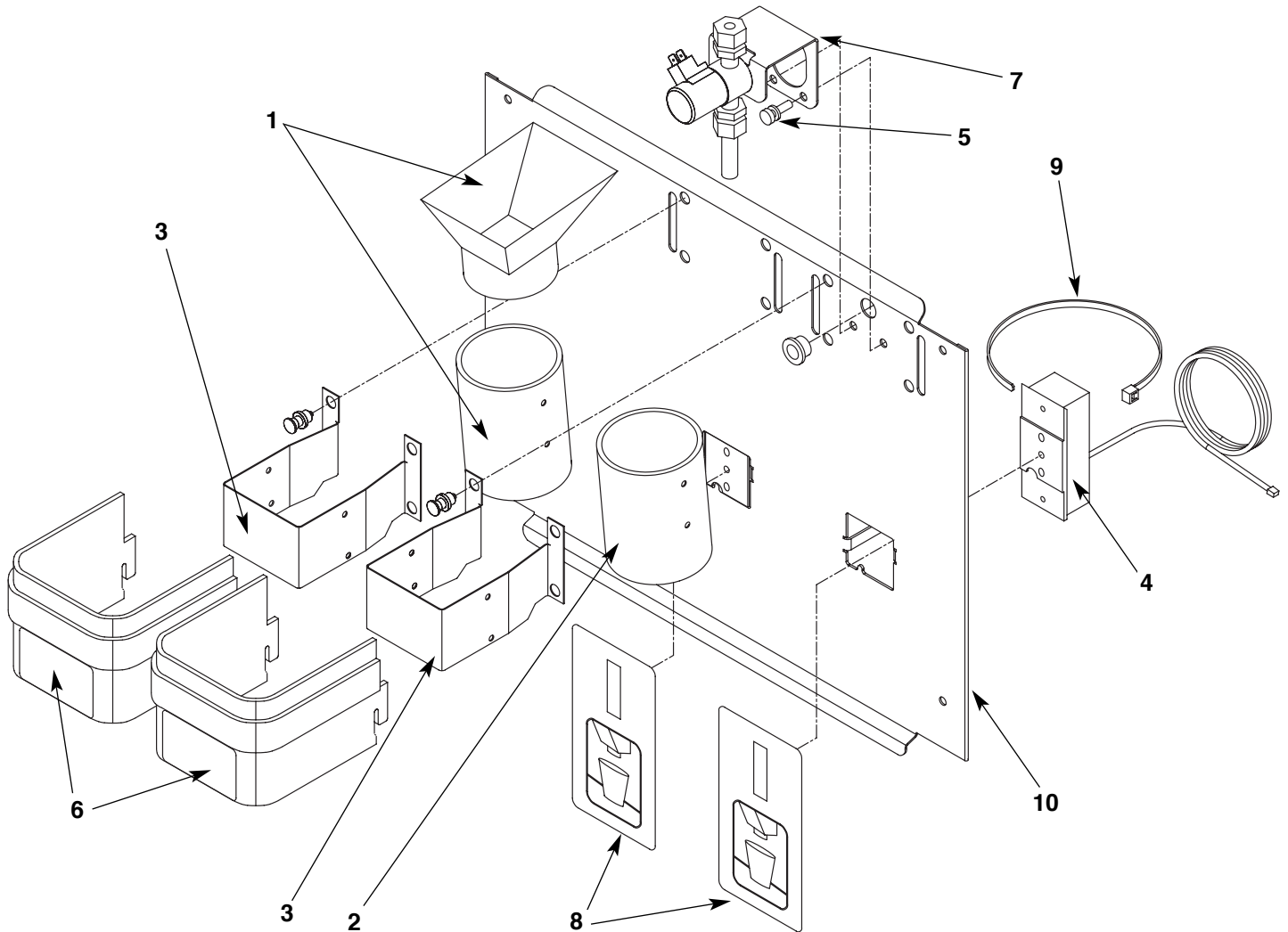
Part #	Description	Reference #
502580	Motor, wheel, long shaft (includes 502537)	1
502384	Drive shaft extension	2
502385	Coupling (includes key) (short shaft motor only)	3
501273	Key, 1/8" sq x 1-1/4 lg	4
502414	Baffle, ice (securing hardware included)	5
502387	Wheel, agitator	6
502390	Rod, threaded (includes knurled nut)	7
502388	Drive bar	8
502386	Agitator, rotating	9
502406	Bracket, capillary tube	See page 31
502404	Retainer, ice tube (2" high)	See page 31
00152017	Retainer, ice tube (2.25" high)	See page 31
502405	Gasket, ice tube	See page 31
502413	Assembly, hopper (includes drain fitting)	10
500504	Float valve and reservoir	11
502389	Bar, spacer	Not shown
502381	Fitting, hopper drain (includes nut), 5/8" barb fitting	Not shown
207095	Fitting, hopper drain, 3/4 MPT, 3/4" barb fitting	12
502416	Switch, interlock	13
502423	Support plate, motor	14
502408	Cover, electrical box	15
502537	Shield, gearmotor	16
207960	Screws, 10-32 x 1/4 (3 needed)	17
00135962	Hopper lid with hopper lid safety switch actuation	18
207809	Hopper lid, dispenser top cover, safety switch actuation (Before SN# B72959)	Not shown

## Dispense chute and splash panel – lever model



Part #	Description	Reference #
502513	Chute assembly, ice	1
502249	Chute, water	2
502247	Bracket, dispense chute (includes four (4) 502057 fasteners)	3
502417	Lever	4
501100	Thumbscrew	5
502409	Switch, dispense, water/ice (includes nut, boot and spacer)	6
502418	Boot, dispense switch button (mounts over the dispense button)	7
502057	Fastener, dispense chute assembly	8
501250	Screws, dispense lever	9
502427	O ring	10
502561	Fitting, 1/4" tube	11
502562	Fitting, 3/8" tube	12
502419	Support bracket, solenoid	13
502243	Valve, solenoid water	14
502420	Tube, water solenoid	15
502421	Solenoid, assembly (includes solenoid, fittings, tube & mounting bracket)	16
502819	Cover, dispense assembly	17
502400	Cover, dispense assembly, ice	18

## Dispense chute and splash panel – SensorSAFE model



Part #	Description	Reference #
502513	Chute assembly, ice	1
502249	Chute, water	2
502247	Bracket, dispense chute (includes four (4) 502057 fasteners)	3
00122978	Sensor (includes 502690 and 203611)	4
501100	Thumbscrew	5
502819	Cover, dispense chute	6
502421	Solenoid assembly (includes solenoid, fittings, tube & mounting bracket, see page 34 for exploded view)	7
502690	Lens, sensor	8
203611	Ty-rap, sensor mounting	9
502675	Splash panel (with drain pan – includes (2) 503611 and (2) 502690)	10
502676	Splash panel (without drain pan – includes (2) 503611 and (2) 502690)	Not shown

## Icemaker components

Part #	Description	Reference #
502724	Drier	1
501187	Coil, condenser	2
502116	Water sensor	3
500504	Float valve & reservoir	4
502078	Fitting, plastic, float valve (includes sleeve & stem)	Not shown
502221	Compression nozzle, single drain	5
	Evaporator (see page 39 for detailed drawing)	6
501820	Shroud, condenser coil	Not shown
502727	Drain pan, evaporator	7
502726	Valve, expansion, thermal	8
502222	Valve, shut-off, water, brass	Not shown
502921	Valve, shut-off, water, plastic	9
00142034	Gearbox & motor, 115V, 60Hz (includes 307192)	10
500376	Strainer, water, threaded connections	Not shown
502920	Strainer, water, push-in connections	11
500474	Fan blade	12
500672	Motor, fan, 115V, 60Hz	13
501188	Bracket, fan motor	14
502782	Overload, compressor, 115V60Hz	15
502731	Compressor, 115V, 60Hz	16
501191	Tubing, plastic, food grade, 1/2 ID (sold by the foot)	17
502079	Tubing, polypropylene, reservoir supply (sold by the foot)	19
502383	Bracket, float valve	20
502403	Tube, ice transport	21
501176	Insulation, ice tube, 12" (305mm) required	22
307192	Bracket, gearmotor mounting	23
502776	Cord and plug, power	24
502732	Hi-pressure cut-out	25
502922	Clip, water shut-off valve	26
502925	Elbow, water, 3/8"	Not shown
502923	Tee, water, 1/4"	27
502604	Tee, 3/4"	28
203534	Tubing, plastic 3/4 ID (sold by the foot)	29
500623	Tubing, plastic, 5/8 ID, bin drain tube before SN# B72959 (sold by the foot)	Not shown
00114199	Adapter, 3/4" x 5/8" (Before SN# B72959)	Not shown

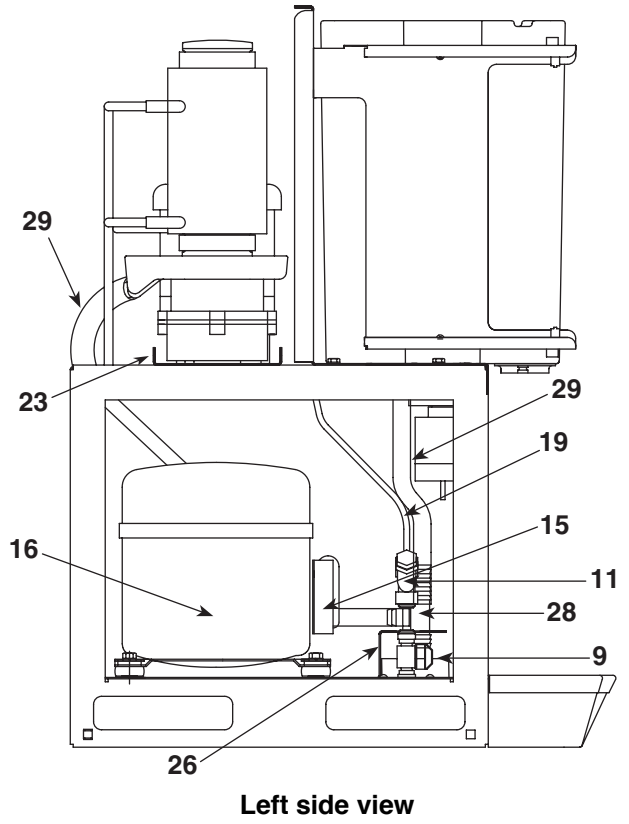
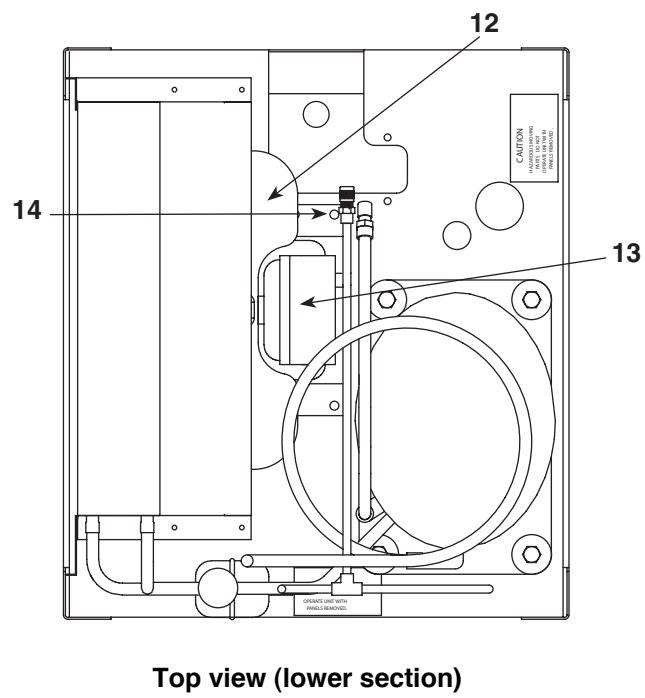
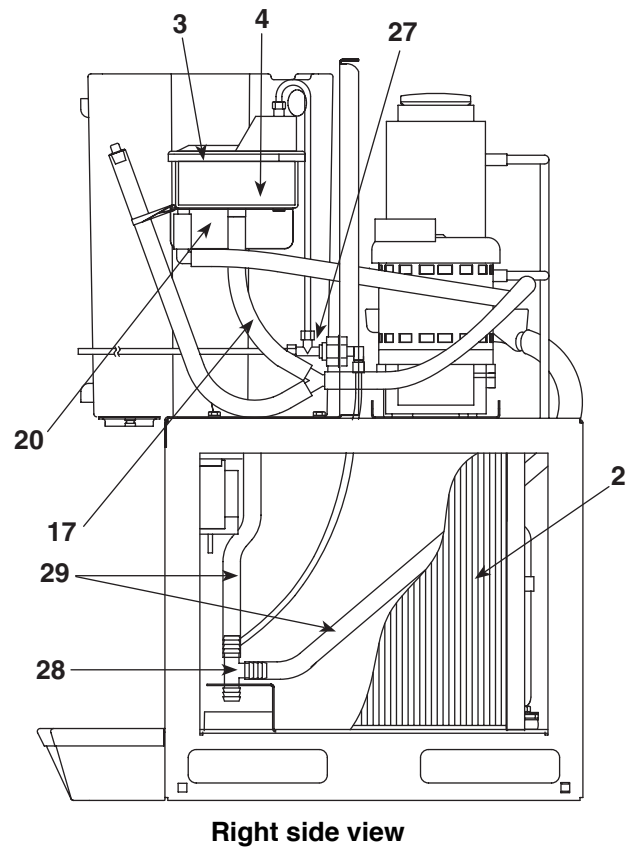
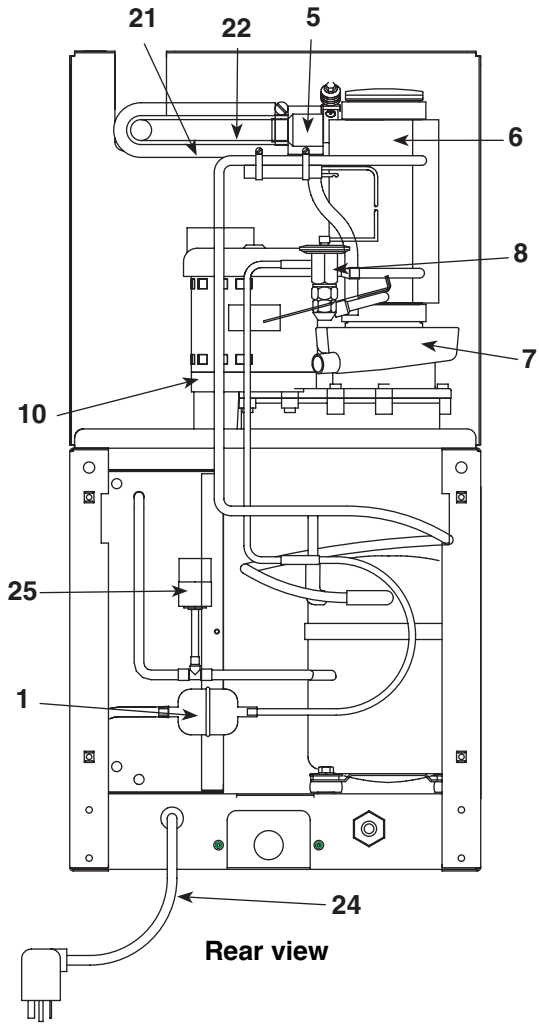
## Water filter kits and cartridges

Part#	Description
00130299	Follett QC4-FL4S water filter system (includes FL4S primary cartridge and head, coarse pre-filter and head, pressure gauge, flushing valve; assembled and installed on mounting bracket)
00130245	Follett FL4S primary replacement cartridge
00130211	Everpure coarse pre-filter cartridge

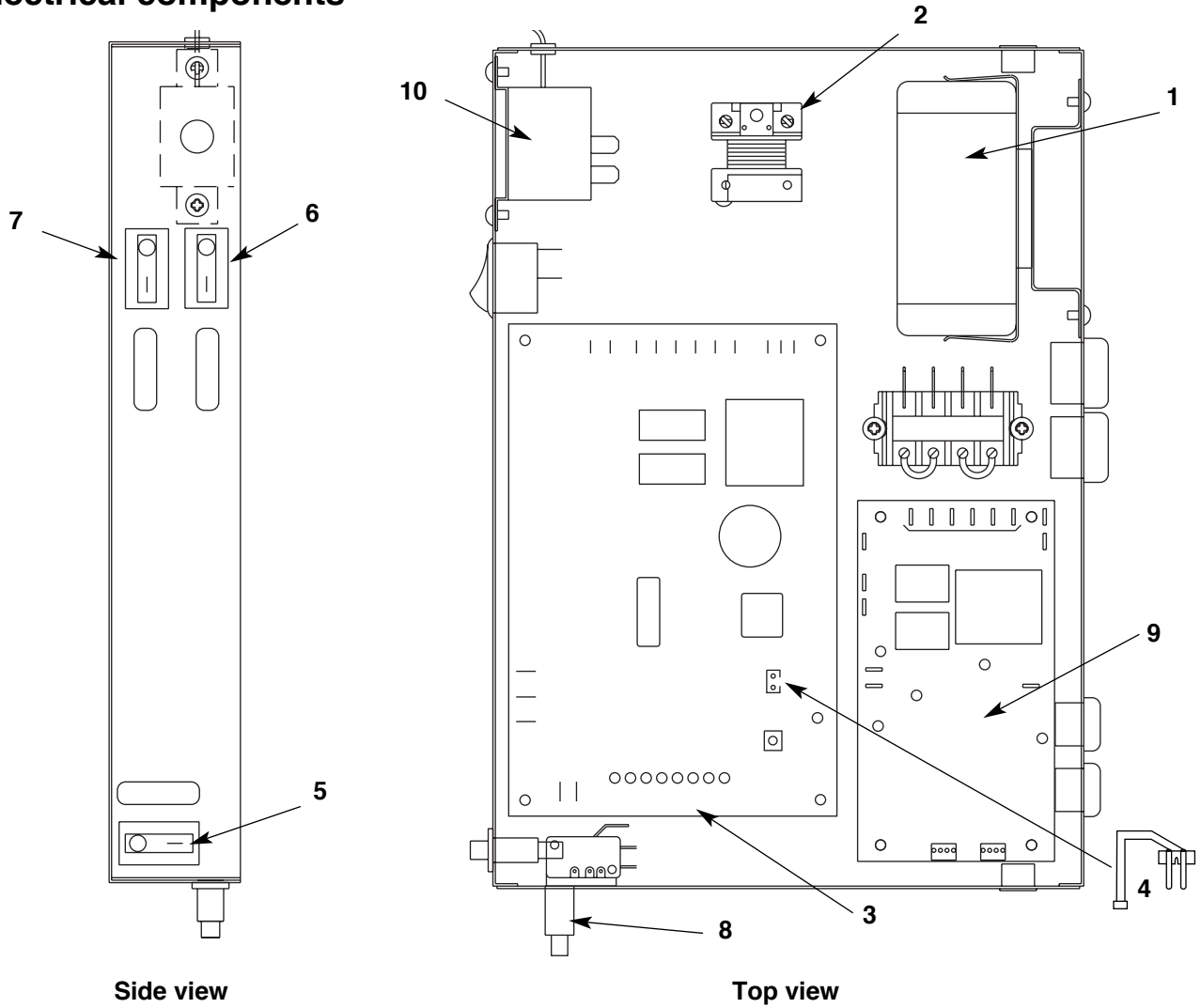
## Ice machine cleaner

Part#	Description
00132001	SafeCLEAN environmentally-friendly cleaner, carton of 24 x 7 oz packets

# Icemaker components



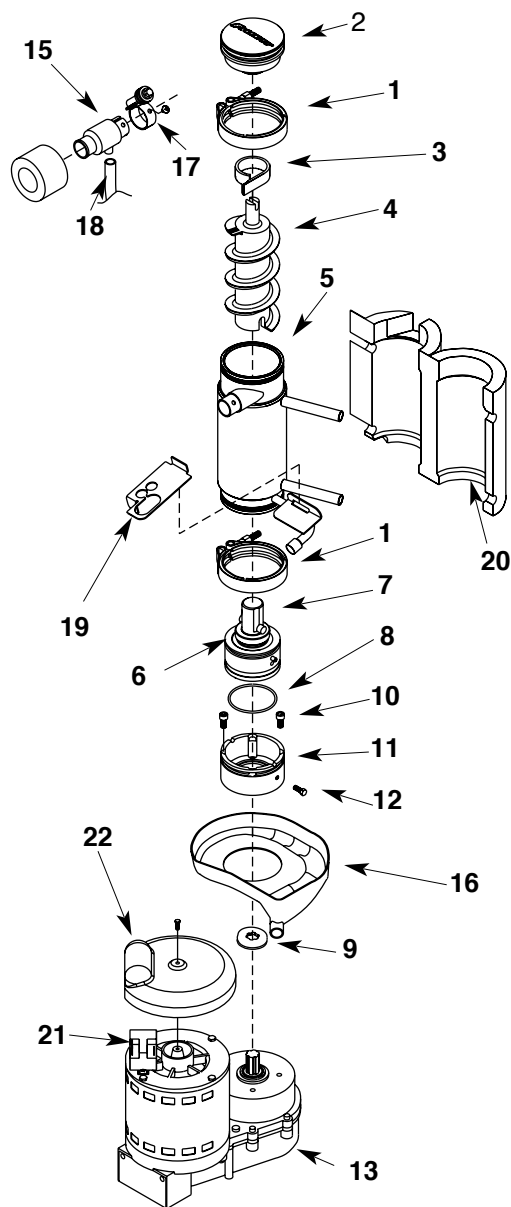
# Electrical components



Part #	Description	Reference #
502780	Capacitor, start, compressor, 115V, 60Hz	1
501588	Relay, start, compressor, 115V, 60Hz	2
502331	Board, control circuit, 115V, 60Hz	3
502116	Water sensor	4
502392	Switch, on/off, compressor	5
502209	Switch, rocker, power	6
502209	Switch, rocker, bin signal	7
502409	Switch, cleaning, SensorSAFE models	8
502242	Control board, SensorSAFE models	9
500514	Bin thermostat	10

# Evaporator replacement parts

Part #	Description	Reference #
502735	Coupling, vee band, includes nut	1
502736	Bearing assembly, top	2
502110	Loop, ice compression, beveled	3
502737	Auger	4
502725	Evaporator (includes insulation jacket, 502740)	5
500496	O ring, bearing housing	6
502738	Bearing assembly, bottom (includes O rings and condensate shield)	7
501063	O ring, mounting base	8
500744	Shield, condensate	9
501080	Screw, Allen 1/4 20 x 1/2 (set of 4)	10
502733	Mounting base, evap. (includes 501063)	11
502227	Bolt, mounting base	12
00142034	Gearbox & motor (includes 307192)	13
502729	Mounting base, gearbox	Not shown
502221	Compression nozzle, with single drain	15
502727	Drain pan, evaporator	16
502226	Clamp, compression nozzle and screw	17
500680	Tubing, compression nozzle drain(s) (sold by foot)	18
501111	Grease, Chevron SRI-2, 14 oz	Not shown
502739	Bracket, drain hose	19
502740	Insulation jacket, evaporator	20
00142042	Relay, gearmotor	21





801 Church Lane • PO Box D, Easton, PA 18044, USA  
Toll free (800) 523-9361 • (610) 252-7301  
Fax (610) 250-0696 • [www.follettice.com](http://www.follettice.com)



208595R09  
09/06