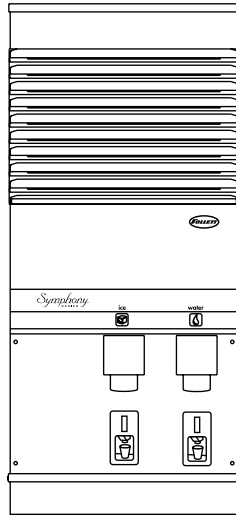


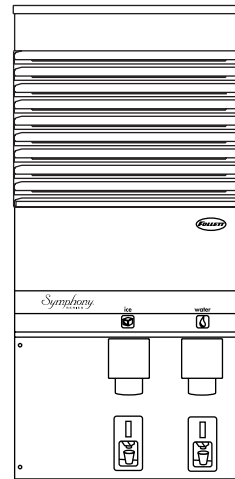
# Symphony™ 25 and 50 Series Ice and Water Dispensers

Order parts online  
www.follettice.com

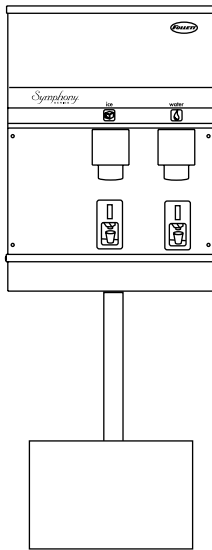
## Installation, Operation and Service Manual



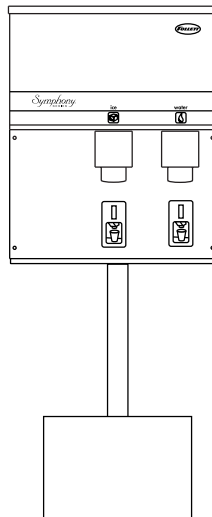
25CT400A/W 50CT400A/W



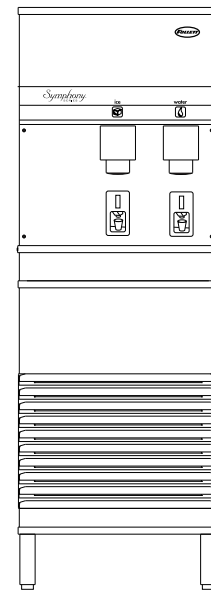
25HT400A/W 50HT400A/W



25CR400A/W 50CR400A/W



25HR400A/W 50HR400A/W



25FB400A/W 50FB400A/W

**Following installation, please forward this manual  
to the appropriate operations person.**

# Table of contents

<b>Before you begin</b> .....	3
<b>Specifications</b> .....	4
<b>Field wiring</b> .....	5
<b>Installation</b> .....	7
Installing freestanding dispensers .....	7
Installing countertop dispensers .....	9
Installing wall mount dispensers .....	11
Installing Satellite-fill™ icemakers .....	13
Installing top mount icemakers .....	14
<b>User information</b> .....	16
Cleaning and sanitizing procedures .....	16
<b>Service Information</b> .....	18
Wiring diagram – lever models .....	18
Wiring diagram – SensorSAFE™ models .....	19
Dispenser troubleshooting .....	20
Troubleshooting SensorSAFE board and sensors .....	21
Disassembly and replacement instructions .....	23
Thermostat locations .....	25
<b>Parts</b> .....	26
Dispenser exterior .....	26
Dispense chute and splash panel areas – lever models .....	27
Electrical box – lever models .....	27
Dispense chute and splash panel areas – SensorSAFE models .....	28
Electrical box – SensorSAFE models .....	29
Wheel motor and drive system .....	29
Hopper components .....	30
Chilled water components .....	31
Countertop dispenser plumbing connections .....	32

## **Follett Corporation Equipment Return Policy**

Follett equipment may be returned for credit under the following conditions:

1. The equipment is new and unused.
2. A return authorization number has been issued by customer service within 30 days after shipment.
3. Follett receives the equipment at the factory in Easton, PA within 30 days after issuance of the return authorization number.
4. The equipment must be returned in Follett packaging. If the packaging has been damaged or discarded, Follett will forward, at the customer's expense, new packaging.

**Note:** Return freight charges are the responsibility of the customer. If equipment is returned and is damaged because of improper packaging, Follett Corporation will not be held responsible.

Credit will be issued when:  
The equipment has been inspected by Follett and deemed suitable to be returned to stock.

**Note:** A 15% restocking charge will be deducted from the credit. If the cost to return the product to stock exceeds 15%, the actual cost will be deducted.

# Welcome to Follett

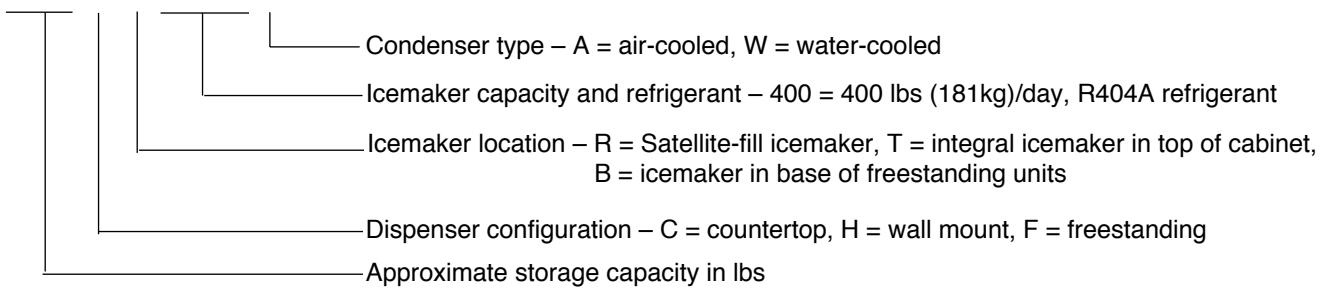
Follett equipment enjoys a well-deserved reputation for excellent performance, long-term reliability and outstanding after-the-sale support. To ensure that this equipment delivers that same degree of service, we ask that you review the installation portion of this manual before beginning to install the unit. Our installation instructions are designed to help you achieve a trouble-free installation. Should you have any questions or require technical help at any time, please call our technical service group toll free at (800) 523-9361 or (610) 252-7301.

## Before you begin

After uncrating and removing all packing material, inspect the equipment for concealed shipping damage. If damage is found, notify your shipper immediately and contact Follett Corporation for help in filing a claim, if necessary.

Check your paperwork to determine which model you have. Follett model numbers are designed to provide information about the type and capacity of Follett equipment. Following is an explanation of model numbers:

### 50CT400A



### Important cautions

- **Do not tilt any unit further than 30° off vertical during uncrating or installation**
- **Dispenser bin area contains mechanical, moving parts. Keep hands and arms clear of this area at all times. If access to this area is required, power to unit must be disconnected first.**
- **Follett recommends a Follett QC4-FL4S water filter system (item# 00130299) be installed in the icemaker inlet water line**
- **Prior to operation clean and sanitize the dispenser in accordance with instructions found in this manual**
- **Ice is slippery. Be sure counters and floors around dispenser are clean, dry and free of ice.**

# Specifications

## Electrical

- Models with Satellite-fill icemakers (25CR400A/W, 50CR400A/W, 25HR400A/W, 50HR400A/W)

	<b>Icemaker</b>	<b>Max. fuse</b>	<b>Dispenser</b>	<b>Max. fuse</b>
Basic electrical: 115V/60Hz/1 phase	11.0 amps	20 amps	4.0 amps	20 amps

- Freestanding models and models with integral icemakers (25FB400A/W, 50FB400A/W, 25CT400A/W, 50CT400A/W, 25HT400A/W, 50HT400A/W)

	<b>Total system</b>	<b>Max. fuse</b>
Basic electrical: 115V/60Hz/1 phase	14.0 amps	20 amps

- Dispensers and Satellite-fill icemakers are supplied with 7-foot power cord with NEMA 5-20 hospital grade plug. Connect to 20 amp circuit fuse or breaker.

**Note:** It is preferred that circuit be protected by a GFCI.

## Ambient

Air temp	100° F/38°C max.	50°F/10°C min. (best performance below 80°F/27°C)
Water temp	90°F/32°C max.	40°F/4°C min. (best performance below 70°F/21°C)
Water pressure	70 P.S.I. max.	10 P.S.I. min.

## Plumbing

	<b>25/50 CR with Satellite-fill icemaker</b>	<b>25/50 HR with Satellite-fill icemaker</b>	<b>25/50 CT with integral icemaker</b>	<b>25/50 HT with integral icemaker</b>	<b>25/50 FB icemaker in base</b>
Dispenser drain	3/4" FPT	3/4" ID tubing	3/4" FPT	3/4" ID tubing	3/4" FPT
Icemaker drain	3/4" MPT	3/4" MPT	—	—	3/4" MPT
Dispenser water inlet	3/8" FPT	3/8" FPT	3/8" FPT	3/8" FPT	3/8" FPT
Satellite-fill IM water inlet	3/8" OD push-in	3/8" OD push-in	—	—	—
Cond. inlet – w/c only	3/8" FPT	3/8" FPT	3/8" FPT	3/8" FPT	3/8" FPT
Cond. drain – w/c only	3/8" FPT	3/8" FPT	3/8" FPT	3/8" FPT	3/8" FPT

**Note:** Water shut-off recommended within 10 feet (3m) of dispenser. Drain to be hard piped and insulated, and maintain slope of at least 1/4" per foot (6mm per 30.4cm run) of slope. All plumbing connections must be made in accordance with local building codes.

## Ventilation clearances

Countertop and wall mount models with Satellite-fill icemaker (25CR400A/W, 50CR400A/W, 25HR400A/W, 50HR400A/W) — none. 12" (305mm) at top advised for service.

Countertop and wall mount models with integral icemaker (25CT400A/W, 50CT400A/W, 25HT400A/W, 50HT400A/W) — 6" (153mm) at top. 6" (153mm) each side advised for service.

Freestanding models (25FB400A/W, 50FB400A/W) — 4" (102mm) at rear. 12" (305mm) at top advised for service.

## Field wiring for countertop and wall mount dispensers with Satellite-fill icemakers



All field wiring must be installed in accordance with NEC and local electrical codes. Field wiring diagram is intended only to aid electrician or technician in understanding how equipment works.

Model	Electrical connection	Circuits required
25FB400A/W, 50FB400A/W	cord & plug provided	115/60/1, 20 amp max. fuse size
25CT400A/W, 50CT400A/W 25HT400A/W, 50HT400A/W	cord & plug provided	115/60/1, 20 amp max. fuse size
25CR400A/W, 50CR400A/W 25HR400A/W, 50 HR400A/W	cord & plug provided	115/60/1 dispenser: 20 amp max. fuse size ice maker: 20 amp max. fuse size



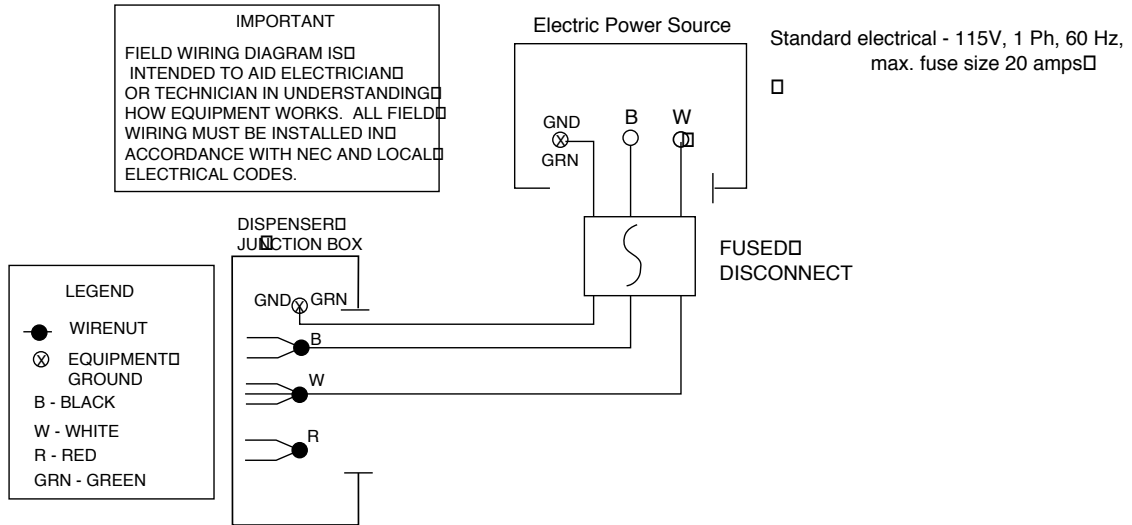
**Attention – Should local codes require a hard-wired connection and/or shielded wiring, eliminate the cord and plug(s) and follow the appropriate field wiring diagram on the following page.**

See Icemaker Installation and Operation manual for recommended junction box preparation of hard-wired Satellite-fill icemakers.

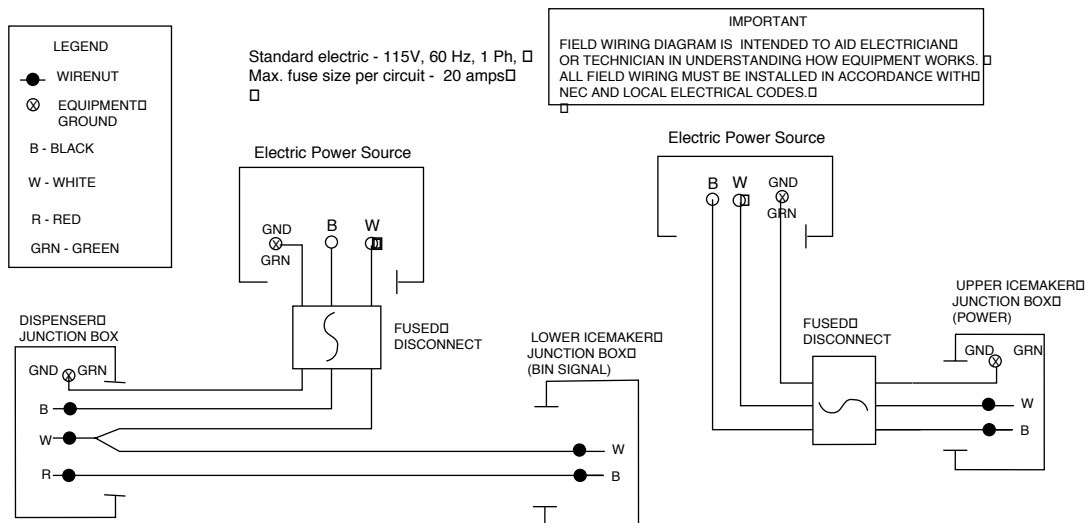
# Field Wiring diagrams

(For installations requiring hard-wiring equipment)

## Freestanding dispensers, countertop and wall mount dispensers with integral icemakers



## Countertop and wall mount dispensers with Satellite-fill icemakers



# Installation procedure

## Before you begin

- **All dispensers must be installed level in both directions to ensure proper operation**
- **Required ventilation and recommended service clearances:**
  - Countertop and wall mount models with Satellite-fill icemaker (25CR400A/W, 25HR400A/W, 50CR400A/W, 50HR400A/W) — none. 12" (305mm) at top recommended for service
  - Countertop and wall mount models with integral icemaker (25CT400A/W, 25HT400A/W, 50CT400A/W, 50HT400A/W) — 6" (153mm) at top. 6" (153mm) each side recommended for service
  - Freestanding models (25FB400A/W, 50FB400A/W) — 4" (102mm) at rear. 12" (305mm) at top recommended for service
- **All countertop dispensers provide the option of taking utilities out the bottom or back of the dispenser.**  
See counter cut-out on page 9 (Fig. 2) for bottom exiting utilities on units with and without drain pans. For installations where utilities will exit through back of dispenser, refer to back view drawings.
- **Wall mount models are designed for use above sinks or custom drain pans, and are not normally equipped with integral drain pans.** Front of sink should be a minimum of 23" (584mm) from back wall. Connection of utilities through the back for wall mount units is the same as shown in drawings for countertop models except that the drain pan is absent.
- **SensorSAFE dispensers are shipped with a plastic, protective film on sensor lenses. For proper operation, plastic film must be removed after installation.**

## Installing freestanding dispensers

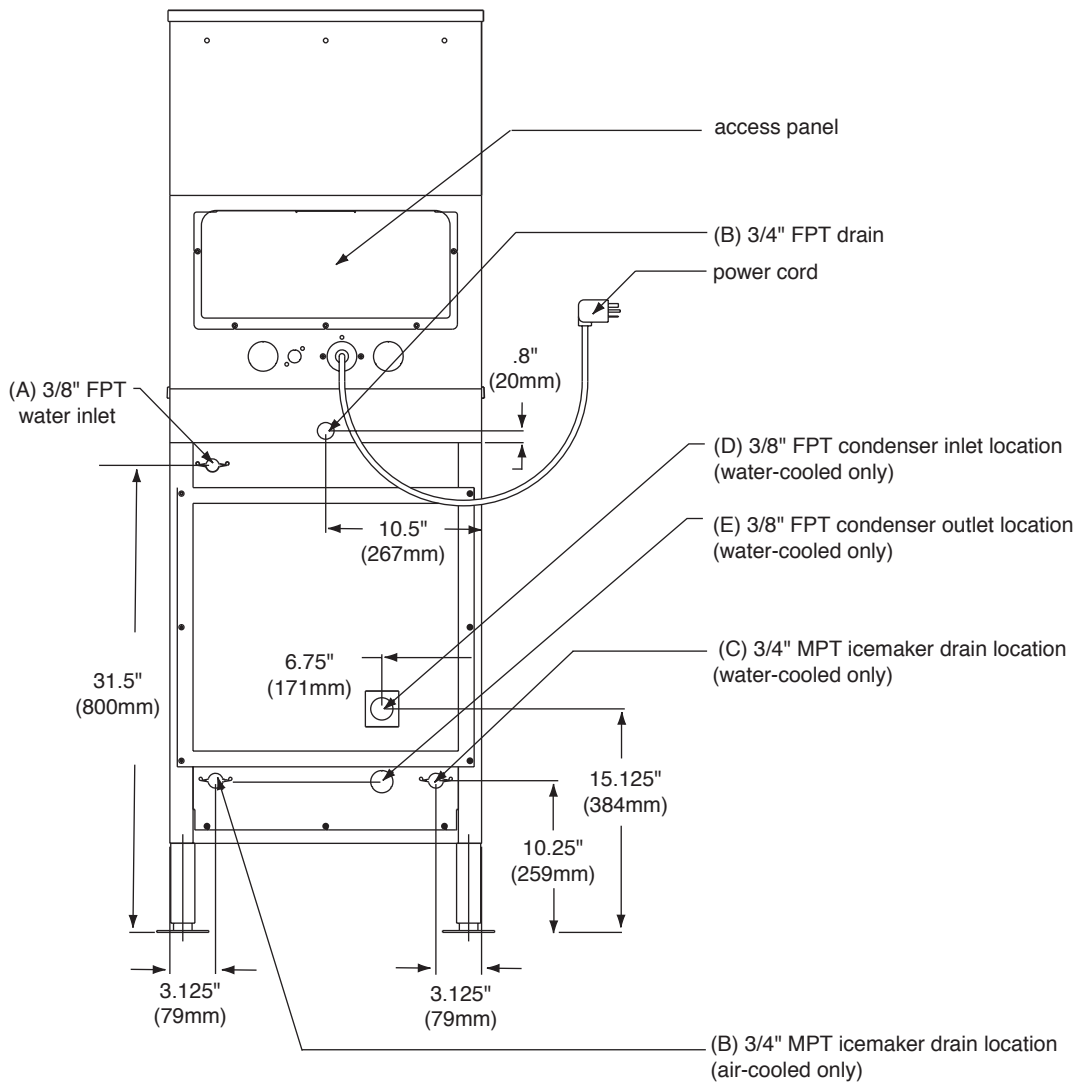
1. Carefully tip dispenser back to expose underside and block up in place.



**Do not tilt unit further than 30° off vertical.**

2. Remove legs from shipping box (taped to drain pan of dispenser) and screw into dispenser bottom, taking care to seat legs securely against underside of dispenser.
3. Position dispenser in desired location and adjust legs to level in both directions.
4. Connect water supply to 3/8" FPT fitting on back of dispenser (Fig. 1A).
5. Remove 3/4" dispenser drain line plug from back of unit and discard. Connect separate drain lines to 3/4" FPT dispenser drain fitting (Fig.1B), and 3/4" MPT icemaker drain fitting (Fig. 1C) on back of dispenser.
6. Run drain lines to wall or floor drain. Provide an air break between the drain lines and drain. If icemaker drain fitting is below an intended wall drain, a condensate pump must be used.
7. If icemaker is a water-cooled unit, connect water-cooled condenser supply line to 3/8" FPT condenser inlet fitting on back of dispenser (Fig.1D).  
**Note:** Do not run condenser supply water through icemaker water filter system.
8. Connect condenser drain line to 3/8" FPT condenser outlet fitting on back of dispenser (Fig.1E).  
**Important:** Do not connect condenser drain line to any other drain lines.
9. Plug dispenser into 20 amp rated NEMA 5-20 wall socket.
10. Remove front cover of base section by removing two screws at bottom corners of cover. Allow cover to drop approximately 3/8" (5mm) and pull forward.
11. Turn on water supply and check that water level in float reservoir (when full) is within 1/4" (6mm) of mark on side of reservoir, and that float moves freely. Check for leaks.

**Fig. 1 – Rear connections, freestanding models**



12. Verify that water sensor tabs are immersed in water in reservoir.
13. Remove top front cover by removing two screws at bottom corners of cover. Lift cover slightly and pull forward.
14. If dispenser is equipped with SensorSAFE remove protective plastic coating from dispense sensor labels.
15. Turn on dispenser power and bin signal rocker switches. Check dispenser and icemaker operation.
16. Sanitize icemaker according to instructions in icemaker manual. Discard ice made during sanitizing process.
17. Turn off icemaker bin signal switch.
18. Remove dispenser hopper lid; clean and sanitize dispenser according to instructions beginning on page 16.
19. Turn icemaker bin signal switch on and replace front covers, securing with screws.



# Installing countertop dispensers



**Dispensers with top mount icemakers cannot be mounted on legs. They must be bolted to counter. Use gloves when lifting icemaker to protect hands from sheet metal edges.**

1. Position dispenser in desired location, mark dispenser outline on counter and remove dispenser.
2. Drill four 3/8" (5mm) holes in counter (Fig. 2) to anchor dispenser to counter.

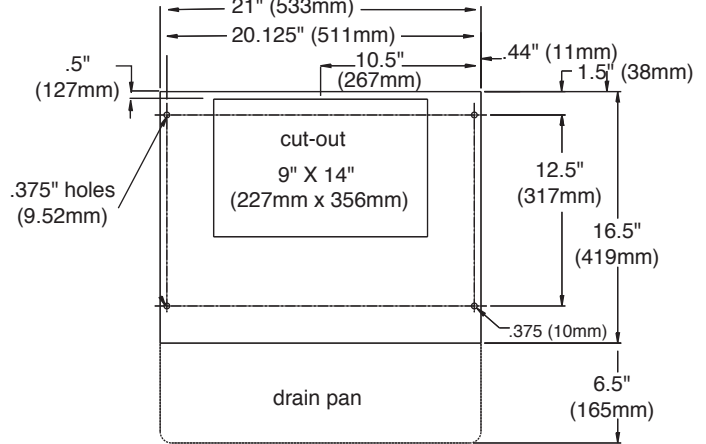
**Follett countertop dispensers can have any or all utilities run directly through counter or out rear of dispenser. For dispensers with any utilities exiting through counter, make counter cut-out (Fig. 2)**

3. If ice transport tube will exit out rear of dispenser, remove ice transport tube knock-out (Fig. 5G) from rear of dispenser.

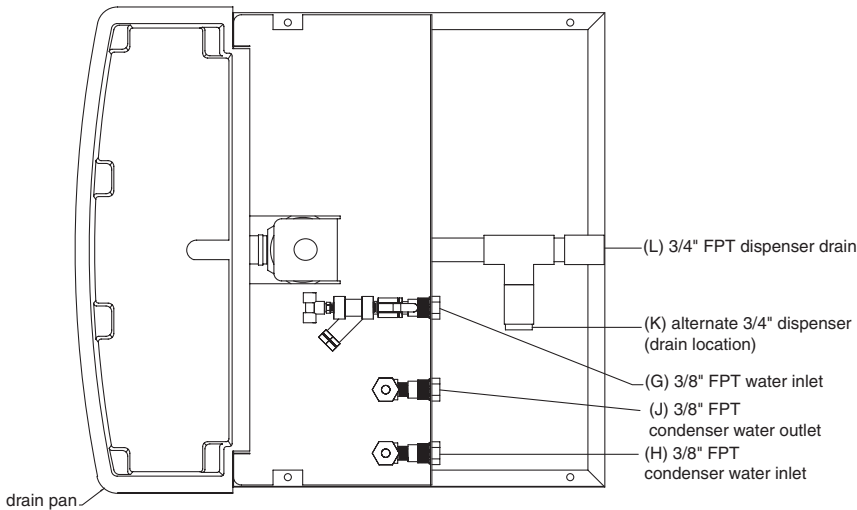
**Note:** Utility connections can be accessed through front of dispenser by removing stainless steel splash panel, or by removing access panel (Figs. 4, 5) on back of dispenser.

4. If any electric utilities or water line will be connected through rear of dispenser, remove utility knock-out (Figs. 4, 5F) from rear of dispenser and install supplied protective grommet.

**Fig. 2 – Counter cut-out, all models**

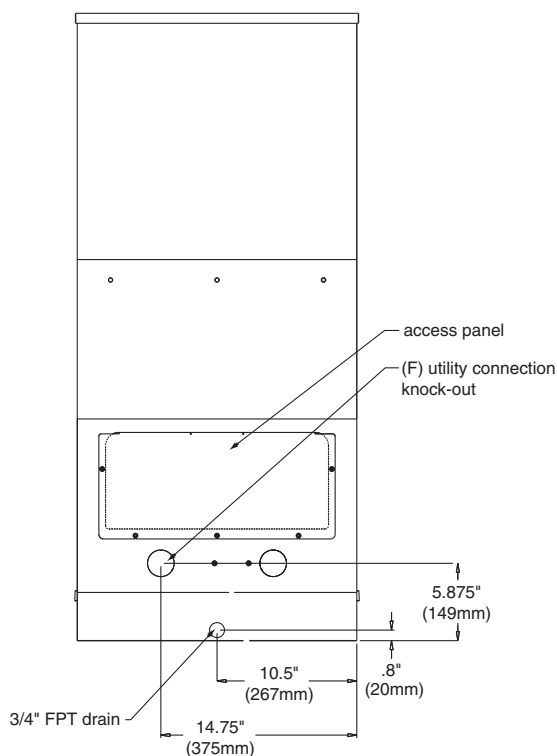


**Fig. 3 – Top view, dispenser plumbing connections countertop**

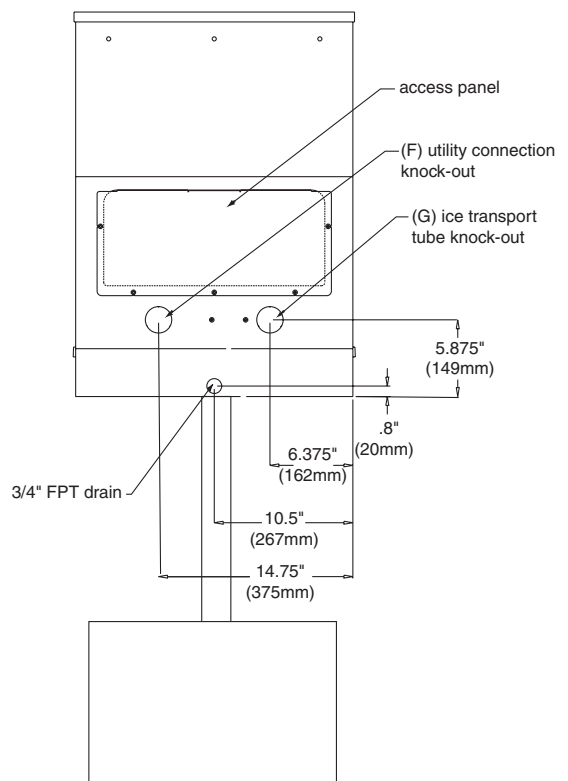


5. If power is to be supplied through counter cut-out, complete steps 6-9. If power is to be supplied through rear of dispenser, proceed to step 10.
6. Temporarily remove rear access panel (Figs. 4 and 5) from rear of dispenser.
7. Loosen junction box mounting screws. Lift junction box and power cord up until cord and mounting screws clear notches on rear panel of dispenser. Remove Phillips head screws from right side of junction box.
8. Rotate junction box 90 degrees so that screw holes on right side of junction box align with holes on rear dispenser panel. Resecure junction box to dispenser using Phillips head screws.
9. Place power cord inside dispenser and replace access panel (Figs. 4, 5) to rear of dispenser.  
**Note:** For dispensers to be installed with utilities connected through rear of dispenser, it may be easier to make preliminary connections before dispenser is set in place.
10. Apply a thick bead, approximately .1/4" (6mm) diameter, of NSF listed silicone sealant (Dow-Corning RTV-732 or equivalent) 1/4" (6mm) inside marked outline of dispenser.
11. Carefully position dispenser on counter.
12. Remove four screws securing splash panel to front of dispenser and gently lay splash panel on counter. (Water line to solenoid valve can be disconnected from water inlet valve by pushing on ring at end of inlet fitting while pulling on tubing.)
13. Secure dispenser to counter with four 3/8" bolts (supplied by others).
14. Smooth excess sealant around outside of dispenser.
15. Run water supply line from back of dispenser through utility knock-out (Figs. 4, 5F) or up through counter cut-out. Connect water supply line to 3/8" FPT fitting on (Fig. 3G) utility flange at bottom of dispenser.
16. Remove 3/4" drain connection plug from either fitting at rear of dispenser (Fig. 3L) or internal fitting (Fig. 3K), as appropriate. Connect and run a dedicated drain line to wall or floor drain. An air break should be provided.
17. Proceed with either Satellite-fill or top-mounted icemaker connection instructions, as appropriate.

**Fig. 4 – Rear connections, countertop models with integral icemakers**



**Fig. 5 – Rear connections, countertop models with Satellite-fill icemakers**



## Installing wall mount dispensers

1. Install supplied wall bracket with six 3/8" diameter fasteners as shown in Fig. 7.

**Note:** Three holes are available at each fastening site to allow capture of studs/support within wall.

**Steps 2 - 3 are required for models with integral icemaker only (25HT400A/W and 50HT400A/W).**

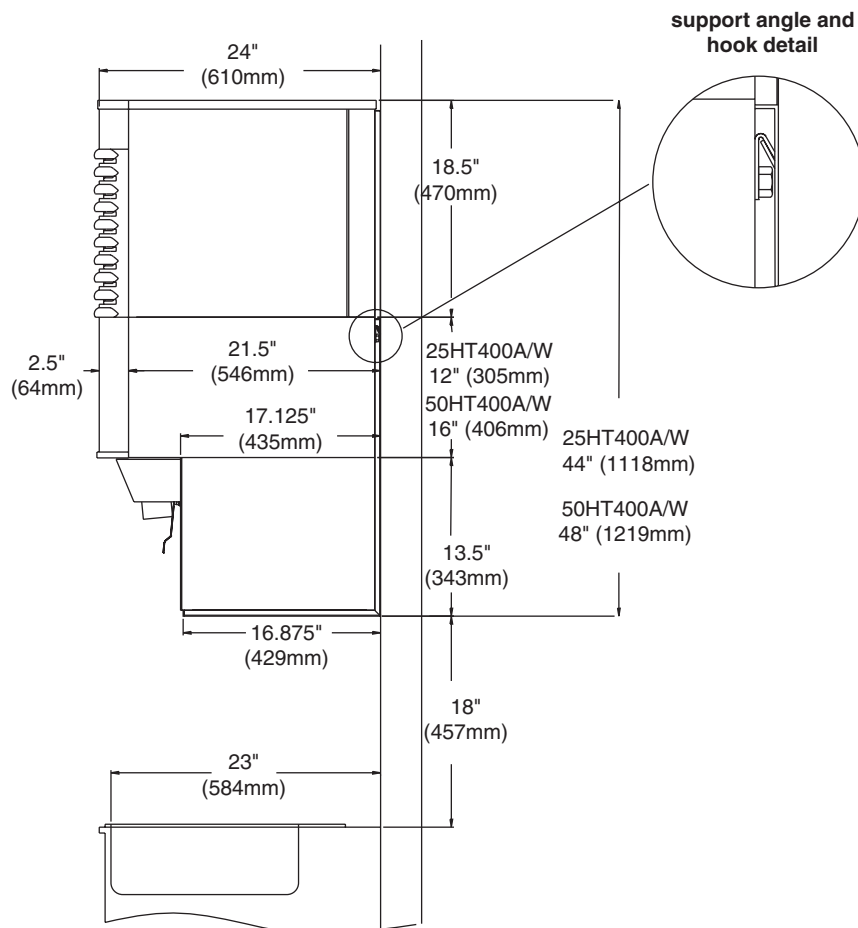
2. For models with integral icemaker, use straight edge to position filler strip flush with top edge of wall bracket.
3. Fasten filler strip to wall as shown in Fig. 8.
4. For all models, cut utility hole in wall (Figs. 7 and 8) using wall bracket as template.
5. Lift dispenser onto wall bracket, positioning unit so that hook on back of dispenser is captured by wall bracket support angle (Fig. 6, hook detail).



**Do not rest dispenser weight on bottom front edge of wall bracket.**

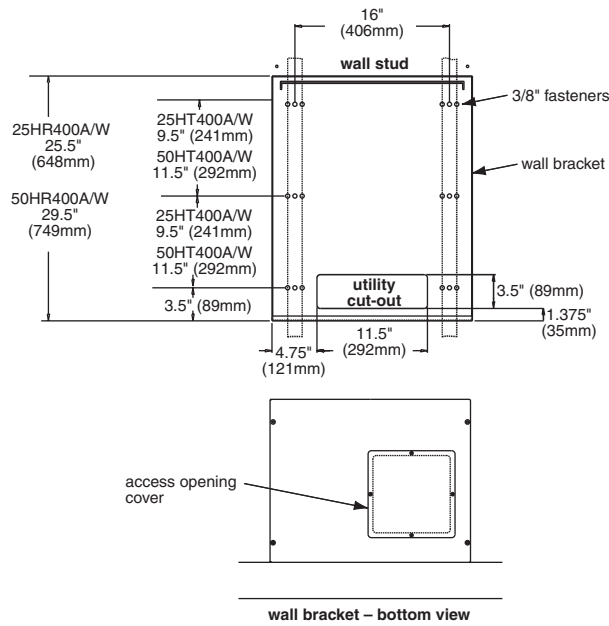
6. Install four 1/4-20 screws through bottom of wall bracket into bottom of dispenser to secure dispenser to bracket.
7. Remove splash panel. Water line to solenoid valve can be disconnected from water inlet valve by pushing on ring at end of inlet fitting while pulling on tubing.

**Fig. 6 – Side view and angle detail for wall mount units without drain pan with integral icemaker (in top of cabinet).** Wall mount units with Satellite-fill icemakers will not require installation of a filler strip.

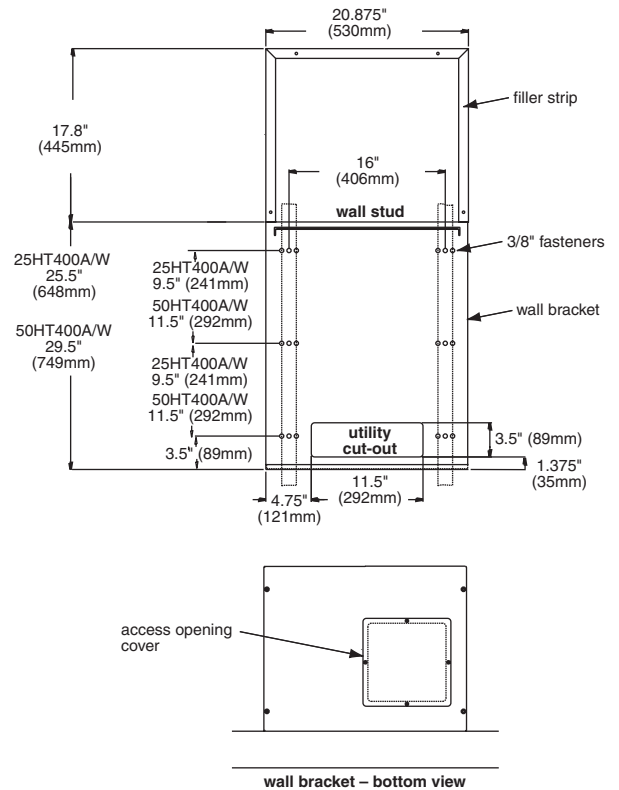


8. Remove utility knock-out (Fig.4, 5F) from rear of dispenser and install supplied protective grommet. For dispensers using remote icemakers, remove ice transport tube knock-out (Fig. 5G) from rear of dispenser.
9. Run water supply line from back through utility knock-out (Fig. 5F) and connect water supply line to 3/8" FPT fitting on utility flange at bottom of dispenser (Fig. 3G).
10. Connect and run a dedicated drain line from 3/4" drain tube to wall or floor drain. An air break should be provided.
11. Proceed with either remote or top-mounted icemaker connection instructions, as appropriate.

**Fig. 7 – Mounting dimensions for wall mount units without drain pan with Satellite-fill icemaker**



**Fig. 8 – Mounting dimensions with wall mount units without drain pan with integral icemaker**



## Installing Satellite-fill icemakers

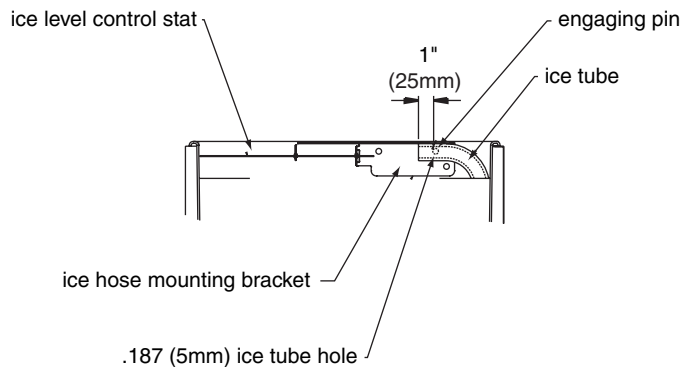
Models 25CR400A/W, 50CR400A/W, 25HR400A/W, 50HR400A/W



**See Icemaker Installation Manual (form #208600) for critical installation instructions for Satellite-fill icemakers. Failure to comply with these instructions will result in poor performance and void warranty.**

1. Install Satellite-fill icemaker following instructions in icemaker manual.
2. Run uninsulated ice transport tube from dispenser through ice transport tube knock-out (Fig. 5G) or through counter opening to icemaker.
3. Insulate ice transport tube by sliding insulation over tube.
4. Adjust insulation to cover all exposed ice transport tubing including tubing inside dispenser cabinet.
5. Check that insulated ice transport tube runs continuously uphill (with no dips) from icemaker to dispenser.
6. Run bin signal wire from dispenser through utility knockout (Fig. 5F) or counter cut-out to icemaker and connect bin signal wire (two-conductor twist lock) to bin signal plug on icemaker.
7. Plug dispenser power cord into 20 amp rated NEMA 5-20 wall socket.
8. Turn on dispenser water supply and check for leaks. Replace splash panel.
9. If dispenser is equipped with SensorSAFE remove protective plastic coating from dispenser lenses.
10. Remove top front cover by removing two screws at bottom corners of cover. Lift cover slightly and pull forward. Turn on power and bin signal rocker switches. Replace front cover and secure with screws. Test operation.
11. Clean and sanitize icemaker following instructions in icemaker manual. Discard ice made during sanitizing process.
12. Clean and sanitize dispenser hopper following instructions on page 16. Installation is complete.

**Fig. 9 – Ice transport tube and ice level control stat mounting for freestanding dispensers and countertop units with Satellite-fill icemaker**



## Installing top mount icemakers

Models 25CT400A/W, 50CT400A/W, 25HT400A/W, 50HT400A/W



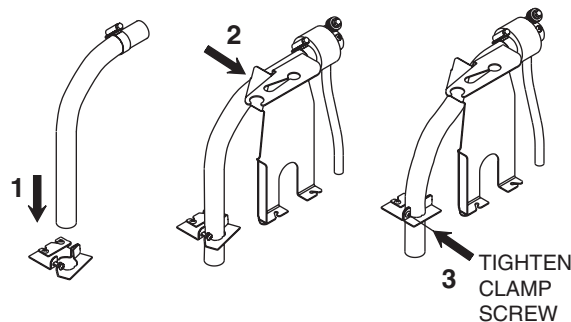
**Dispensers with top mount icemakers cannot be mounted on legs. They must be bolted to counter. Use gloves when lifting icemaker to protect hands from sheet metal edges.**

1. On dispensers equipped with top-mounted, water-cooled icemakers, feed condenser supply and drain lines from back through utility knock-out (Fig. 4F) or through counter, as appropriate. Connect condenser supply line to inlet fitting (Fig. 3H) on utility flange at bottom of dispenser. Connect condenser drain line to outlet fitting (Fig. 3J) on utility flange at bottom of dispenser.

**Note:** Do not run condenser supply water through icemaker water filter system. Do not connect condenser drain line to any other drain lines.

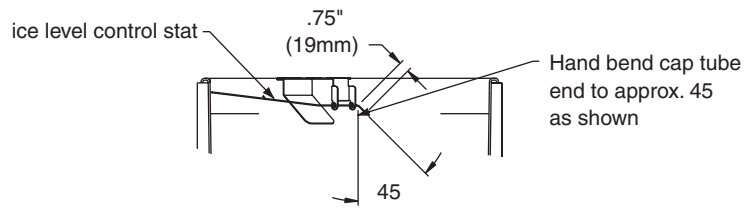
2. Remove dispenser top front cover by removing two screws at bottom corners of cover, lifting cover slightly and pulling forward.
3. Remove icemaker compartment top and side panels.
4. Remove icemaker hold-down bracket from front of icemaker compartment.
5. Lift icemaker onto dispenser top and slide icemaker completely into position, compressor end first. Front of icemaker base must be flush with front of dispenser.
6. Reinstall hold down bracket on front of icemaker with power cord and bin signal cords in notch. Do not cut or pinch cords.
7. Insert loose end of ice transport tube through bracket on icemaker base into hopper access hole. Be sure that transport tube is secured under retainer on float reservoir bracket (Step 2, Fig 10). Tighten transport tube clamp screw to secure ice transport tube.

**Fig. 10 – Ice transport tube**



8. Connect plastic water supply line to fitting at top of float reservoir.
9. Connect vinyl drain from dispenser securely to 120° elbow on icemaker drain line.
10. Connect icemaker two-lead bin signal twist lock plug, and three-lead power twist-lock plug, to dispenser twist-lock connectors.
11. On dispensers equipped with water-cooled icemakers, connect condenser water supply and drain lines to condenser fittings on icemaker.
12. Turn on water supply and check for leaks. Check that water level in float reservoir (when full) is within 1/4" (6mm) of mark on side of reservoir, and that float moves freely. Verify that water sensor tabs are immersed in water in reservoir. Replace splash panel.
13. Plug dispenser power cord into 20 amp rated NEMA 5-20 wall socket.
14. If dispenser is equipped with SensorSAFE remote protective plastic coating from dispense sensor labels.
15. Turn on power and bin signal rocker switches and test operation.
16. Clean and sanitize icemaker following instructions in icemaker manual.
17. Remove dispenser hopper access lid and clean and sanitize dispenser according to instructions on page 16.
18. Replace front cover and secure with screws. Installation is complete.

**Fig. 11 – Ice transport tube and ice level control stat mounting units with top-mounted icemakers**



# User information

## How the dispenser works

Follett's 25 and 50 automatic load ice and water dispensers receive ice from Follett's 400 lb (181kg)/day icemaker located in the dispenser base, in the cabinet top or in a remote location up to 20 ft (6m) away. Ice produced is stored in the bin section of the dispenser. When the dispense lever is pushed, the wheel motor is energized, causing the wheel to turn. This moves ice to the dispense chute where it drops by gravity into the container held below the chute.

In Follett's continuous icemaking process, water freezes to the inside walls of the stainless steel evaporator. A rotating stainless steel auger carries the ice to the top of the evaporator where it is compressed and extruded through a nozzle on the outlet port. The ice is then pushed through a tube to the dispenser bin. When the storage area is full, a bin stat opens and shuts the icemaker off to avoid over-filling of the bin. The icemaker will restart after 20 minutes if the bin is calling for ice.

## How the SensorSAFE accessory works

Follett's SensorSAFE accessory maximizes sanitation and minimizes the possibility of cross-contamination by eliminating physical contact between the cup or container and dispenser. Sensors in the panel use reflected infrared light to detect the presence of the container and send a signal to a control board which then activates the appropriate components for ice or water dispensing.

The SensorSAFE package includes a cleaning switch under the left side of the front cover which temporarily shuts off dispensing to allow cleaning of the panel and lenses. If the switch is not turned back on after cleaning, the dispenser automatically resets after two minutes for normal operation.

SensorSAFE also includes a time limit safety feature which automatically stops ice dispensing after one minute of continuous dispensing. Dispensing can be resumed by moving the container away from the dispenser and returning it to the activation zone.

## How the chilled water accessory works

Follett's chilled water accessory uses ice from the dispenser's storage hopper to chill incoming water supplied to the water station. The water chiller assembly is located in the dispenser cabinet under the storage hopper. As ice is dispensed it is automatically fed into the water chiller assembly to chill the water coil inside the assembly.

## Cleaning and sanitizing procedures



**Always disconnect power before cleaning.**

**Solution A:** Prepare cleaning solution (200 ppm of available chlorine content) of Ecolab Mikro-chlor Cleaner or equal chlorinated detergent. Solution temperature must be 75°F – 125°F (24°C – 52°C).

**Solution B:** Prepare sanitizing solution (50 ppm of available chlorine content) of Ecolab Mikro-chlor Cleaner or equal chlorinated detergent. Solution temperature must be 75°F – 125°F (24°C – 52°C).

Follett recommends the periodic cleaning schedule on page 17 to ensure the quality of ice provided. Use only recommended cleaning solutions. Do not use solvents, abrasive cleaners, metal scrapers or sharp objects.

### Recommended daily cleaning of drain pan

1. Remove all debris from drain pan.
2. Slowly pour 1 gallon (4L) hot water into drain pan to keep drain lines clear.

### Recommended weekly cleaning

1. Wash drain pan and grille with Solution A. Rinse thoroughly.
2. Slowly pour solution of one cup (8oz/237ml) household bleach mixed with one gallon (3.8L) hot water into drain pan to help prevent algae growth in drain lines.



### If dispenser is a SensorSAFE unit:

3. Deactivate dispenser by depressing and releasing clean switch located on left side of unit under top front cover.
4. Clean lens using soft cloth and mild, non-abrasive cleaner.
5. Reactivate dispenser by depressing and releasing clean switch a second time (dispenser automatically reactivates after two minutes).

### Recommended quarterly cleaning of dispenser hopper

**Note:** If icemaker and dispenser are cleaned and sanitized at the same time, icemaker should be cleaned and sanitized first.

1. Remove ice from dispenser.
2. Working inside storage area, remove center thumbscrew from dispense wheel, tilt wheel up toward back to clear baffle and disengage wheel from motor shaft.
3. Remove front cover, chute cover and clear plastic chute.
4. Wipe lid, wheel, baffle and clear plastic chute with damp cloth wrung out in Solution A.
5. Rinse all above items with damp cloth rinsed and wrung out in clear water.
6. Wipe all bin surfaces (including the area under dispense wheel) with a damp cloth wrung out in Solution A .
7. Rinse all bin surfaces thoroughly with damp cloth rinsed and wrung out in clear water.

**Note:** Do not rinse by pouring water into the storage bin, damage to the dispense motor can result.

8. Wipe lid, wheel, baffle, clear plastic chute and all bin surfaces with damp cloth wrung out in Solution B to sanitize. Do not rinse.
9. Reinstall dispense wheel and other components.



**To avoid possible damage to motor assembly, use a damp cloth only. Do not allow water to run through center hole in bottom of bin area.**

### If dispenser is equipped with chilled water accessory:

1. Remove four screws securing splash panel.
2. Disconnect 3/4" drain line from bottom of chilled water canister.
3. Loosen (do not remove) screw securing front bracket of chilled water canister to bottom of dispenser hopper.
4. Rotate canister clockwise to release front bracket, then pull canister forward to disengage rear bracket.
5. Remove chilled water coil from canister and clean with cloth wrung out in Solution A.
6. Wipe inside of chilled water canister with cloth wrung out in Solution A.
7. Rinse all above items with damp cloth wrung out in clear water.
8. Sanitize all above items with damp cloth wrung out in Solution B. Do not rinse.
9. Reinstall chilled water coil into canister (rubber alignment grommet on coil tubing must be located outside chilled water canister to hold coil securely against canister wall).
10. Reinstall chilled water assembly on dispenser and tighten screw securing front bracket.
11. Reconnect 3/4" drain line to chilled water canister.
12. Reinstall splash panel and top front cover.
13. Restore power and test operation.

### Quarterly cleaning of icemaker system

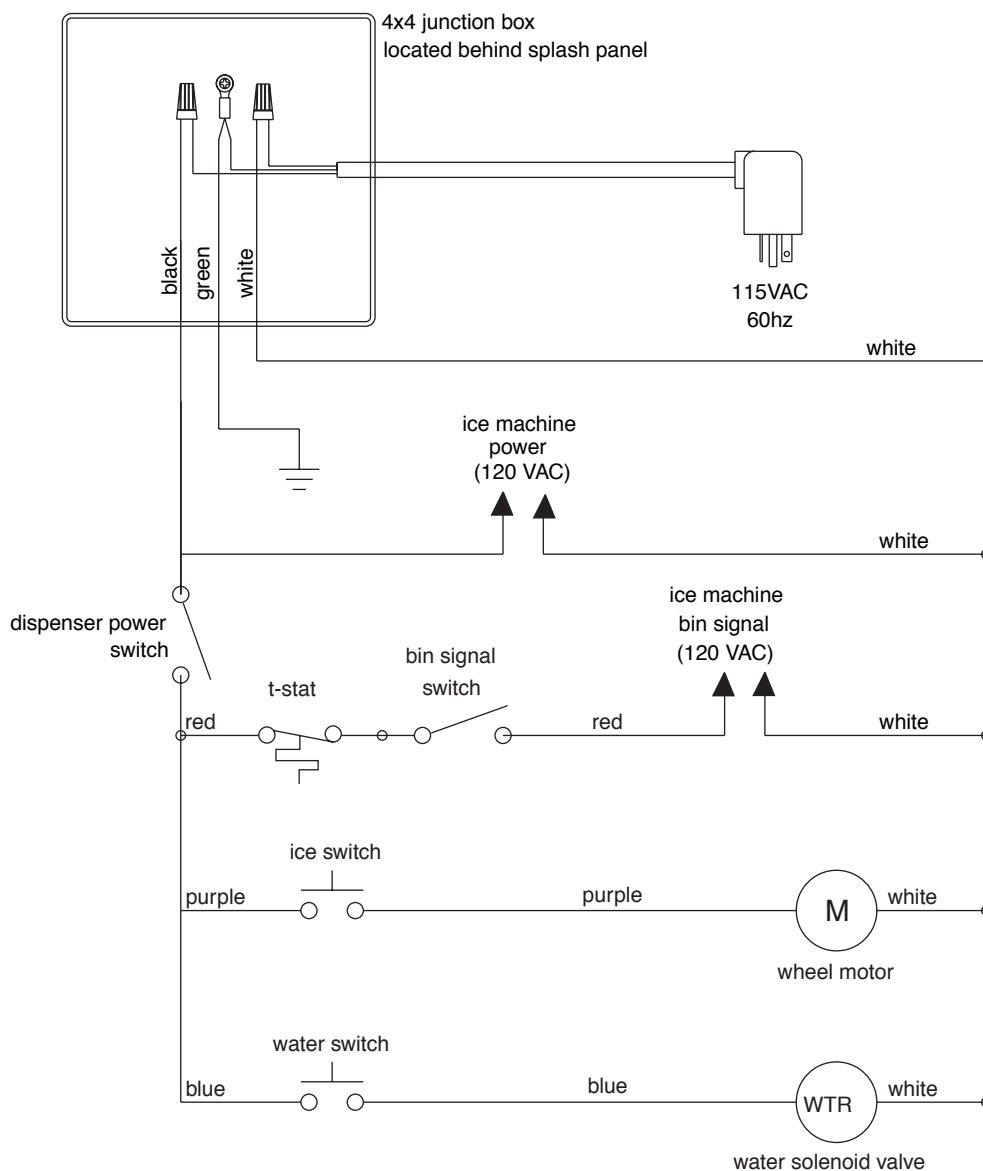
**Units with icemakers require icemaker cleaning at least every 3 months, and more often if local water conditions dictate. Failure to clean icemaker will result in decreased performance and potential damage to icemaker. Refer to Icemaker Operation and Service Manual for specific cleaning instructions.**

# Service information

## Wiring diagrams

### How unit works — lever models

The dispense wheel motor is energized through the power and ice dispense switches. The water solenoid valve is energized through the power and water dispense switches. The icemaker receives the bin signal through the power switch, the normally closed bin thermostat and the icemaker switch. When the bin level thermostat is calling for ice, a 115v bin signal is applied to the bin signal terminals on the icemaker circuit board. When ice builds up around the bin thermostat, the contacts open, cutting the bin signal to the icemaker.

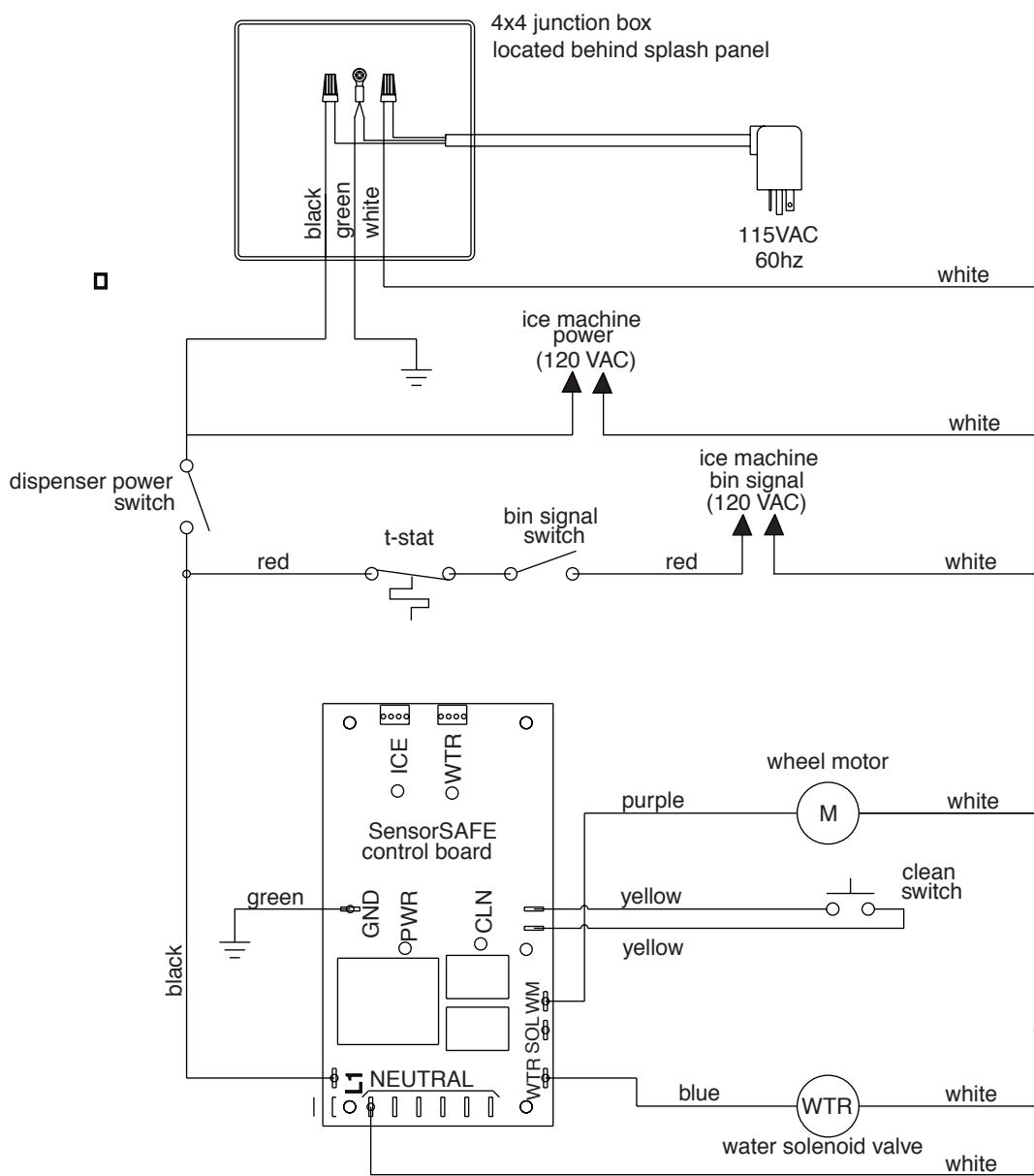


## How unit works — SensorSAFE models

SensorSAFE models provide “touchless” ice and water dispensing. When a container is placed within the actuation zone below the ice or water chute on SensorSAFE dispenser models, an infrared signal reflects off the container and is detected by the sensor. The sensor then sends a signal to the control board to activate the appropriate components to dispense ice or water. LEDs on the board indicate when the board is receiving a signal from the sensors.

A safety, shut-off feature automatically shuts off dispensing after one minute of continuous activation. Dispensing can be restarted by moving the container away and then returning it to the actuation zone.

Dispensing can be temporarily suspended for cleaning by depressing and releasing the clean switch, located under the left side of the top front cover. Depressing and releasing the button a second time will return the dispenser to normal operating state. If the clean switch is not depressed a second time, the dispenser will automatically resume normal dispense operation (CLN LED goes out) after two minutes. An LED on the control board will light to indicate that the dispensing has been suspended by activation of the clean switch.



# Dispenser troubleshooting



**Disconnect power to dispenser and icemaker before putting hands or arms in storage area, or attempting any repair or service to equipment.**

## Before calling for service:

- Check that there is ice in dispenser bin area
- Check that congealed cubes are not causing a jam
- Check that all switches and circuit breakers are on
- Check that all drains are clear

Symptom	Possible cause	Solution
1. Does not dispense ice	<ul style="list-style-type: none"> <li>a. Power switch off or faulty</li> <li>b. Faulty dispense switch</li> <li>c. Wheel motor malfunction</li> <li>d. Drive chain off</li> <li>e. Sprocket key missing</li> </ul>	<ul style="list-style-type: none"> <li>a. Check switch; turn on or replace if faulty</li> <li>b. Replace switch</li> <li>c. Check motor and replace as required</li> <li>d. Reinstall chain</li> <li>e. Install key and tighten sprocket</li> </ul>
2. Does not dispense water	<ul style="list-style-type: none"> <li>a. Dispense switch faulty</li> <li>b. Faulty water solenoid</li> <li>c. Solenoid plugged by debris</li> </ul>	<ul style="list-style-type: none"> <li>a. Check switch and replace if faulty</li> <li>b. Check solenoid and replace if faulty</li> <li>c. Remove and clean valve</li> </ul>
3. Water runs continuously	<ul style="list-style-type: none"> <li>a. Dispense switch contacts burned shut</li> <li>b. Debris preventing valve from closing</li> </ul>	<ul style="list-style-type: none"> <li>a. Check switch and replace if faulty</li> <li>b. Remove and clean valve</li> </ul>
4. Dispense wheel rotates continuously	<ul style="list-style-type: none"> <li>a. Dispense switch contacts burned shut</li> </ul>	<ul style="list-style-type: none"> <li>a. Replace dispense switch</li> </ul>
5. Icemaker runs continuously	<ul style="list-style-type: none"> <li>a. Faulty or incorrectly positioned bin thermostat</li> <li>b. Incorrect field wiring</li> </ul>	<ul style="list-style-type: none"> <li>a. Check for proper positioning (middle of adjustment range); if thermostat does not open when ice is placed on capillary tube, replace thermostat</li> <li>b. Check that icemaker receives bin signal from dispenser</li> </ul>
6. Ice dispenses by itself	<ul style="list-style-type: none"> <li>a. Baffle not adjusted properly</li> <li>b. Faulty dispense switch</li> </ul>	<ul style="list-style-type: none"> <li>a. See page 22 for adjustment instructions</li> <li>b. Replace dispense switch</li> </ul>

# Troubleshooting SensorSAFE board and sensors

## Board guide

LEDs, when illuminated, indicate the following:

- PWR (board power)
- CLN (cleaning, no dispensing cycle)
- ICE (ice dispensing activated)
- WTR (water dispensing activated)

Terminals:

- L1 (incoming power, hot)
- L2 (neutral terminals)
- WTR (power terminal for water solenoid)
- SOL (power terminal for dispense gate solenoid) not used
- WM (power terminal for wheel motor)
- CLN (terminals for clean cycle switch)

### Problem: Does not dispense ice or water

Action	LED Status			Solution
	PWR	CLN	ICE/WTR	
Check LEDs on control board	OFF	OFF	OFF	Check circuit breakers and power switch; restore power or replace defective switch
	ON	ON	OFF	Depress clean switch located under left side of front cover to return board to normal operation
Place cup under drop zone	ON	OFF	OFF	Troubleshoot appropriate lens/sensor and replace if required (see Lens/Sensor Troubleshooting below)
	ON	OFF	ON	Verify power on appropriate output terminal (WTR or WM) on control board and replace board if required; if board tests okay, troubleshoot appropriate dispenser component

### Problem: Dispenses ice or water continuously

Action	LED Status			Solution
	PWR	CLN	ICE/WTR	
Check LEDs on control board	ON	OFF	ON	Troubleshoot appropriate lens/sensor and replace if required (see Lens/sensor troubleshooting below)
	ON	OFF	OFF	If there is power on any output terminal (WTR or WM) on control board, replace board  Remove lens protective cover; adjust funnel so water doesn't drip down lens or behind splash panel

## Lens/sensor troubleshooting

1. Turn dispenser power switch off.
2. Remove splash panel.
3. Disconnect wires from output terminal(s) (WTR, WM) on board.
4. Gently remove appropriate sensor/mounting block assembly from panel by moving block sideways until edge of block clears retaining tab of panel.
5. Inspect lens and sensor assembly for foreign material and remove using non-abrasive cleaner.
6. Turn dispenser power on and test sensor by moving hands through activation area (no closer than 3/16"/5mm in front of sensor).
7. If LED on board turns on and off, sensor is working properly and dispenser may be reassembled. If LED does not come on, switch sensor leads on board and retest. If the opposite LED comes on, board is defective and must be replaced. If LED does not come on, sensor is defective and must be replaced.

# Disassembly and replacement instructions

## Dispense chute removal

1. Remove dispenser front cover.
2. Slide plastic dispense chute cover up and out to remove.
3. Pull out four white plastic fasteners and remove dispense chute.

## Dispense wheel removal and installation

**Note:** Models with top mount icemakers require removal of icemaker before removing wheel.

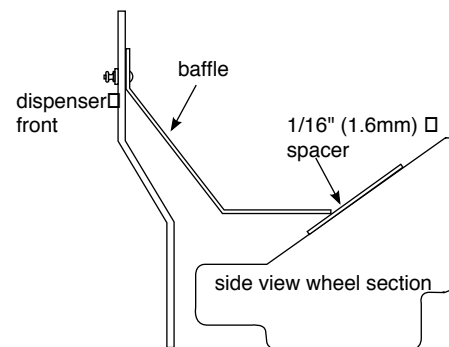
1. Remove all ice from storage area of dispenser.
2. Remove center thumbnut from dispense wheel.
3. Remove thumbnuts holding baffle inside bin and remove baffle.
4. Tilt rear of wheel up and lift off motor drive shaft.
5. After reinstalling wheel, secure baffle loosely with thumbnuts, but do not tighten.
6. Place a 1/16" (2mm) spacer against wheel and allow baffle to drop until it touches spacer.
7. Tighten thumbnuts and remove spacer.

## Drive bar removal

1. Remove dispense wheel from dispenser (see above).
2. Pull drive bar out of its channel in bottom of wheel.

## Wheel motor assembly removal

1. Shut water off. Remove front cover.
2. Remove dispense wheel and dispense chute covers (see above).
3. Remove splash panel. Water line to solenoid valve can be disconnected from water inlet valve by pulling on ring at end of inlet fitting.
4. Disconnect wiring to panel and set panel aside.
5. Disconnect wires on motor.
6. Remove four bolts (7/16" socket) holding motor assembly to bottom of dispenser.
7. Remove motor assembly.

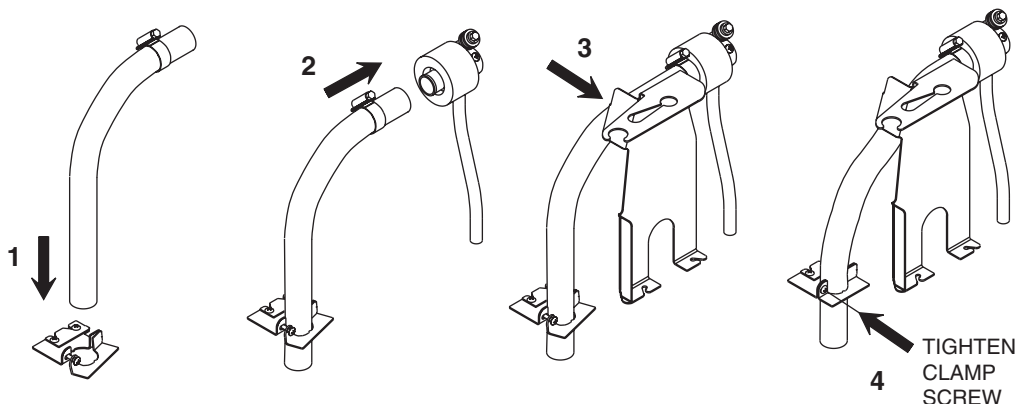


## Ice transport tube replacement

Models 25CT400A/W, 25HT400A/W, 50CT400A/W, 50HT400A/W



Only use tubing supplied by Follett Corporation.



## Ice transport tube replacement

Models 25FB400A/W, 50FB400A/W, 25CR400A/W, 50CR400A/W



**Correct installation of ice transport tube is critical to Satellite-fill icemaker performance. Replacement ice transport tubes for Satellite-fill icemakers must be insulated and run continuously from icemaker to dispenser with no dips or bends with a radius of less than 6" (153mm).**

1. Remove top and rear access panel from dispenser (lower front panel in freestanding unit).
2. Disconnect existing ice tube from engaging pin on transport tube bracket in ice storage bin and pull down through dispenser chase.
3. Disconnect opposite end of tube from icemaker.
4. Run end of new ice transport tube with 3/16" (5mm) hole through ice transport tube knockout (Fig. 5G) in back of dispenser or through counter into bottom of dispenser, being careful to avoid any bends with less than 6" (153mm) radius.
5. Insert tube in internal chase in rear inside corner of dispenser (left side as you face dispenser) and push up into storage area.
6. Push the 3/16" (5mm) hole near end of tube into pin on ice tube bracket (see drawing below).

### **Steps 7-8 for units with Satellite-fill icemakers only**

7. Install supplied insulation to run of transport tube required for your site, leaving approximately 2" (51mm) of tube exposed at free end.
8. Check that insulated tube runs continuously from icemaker to dispenser with no dips.

### **All units**

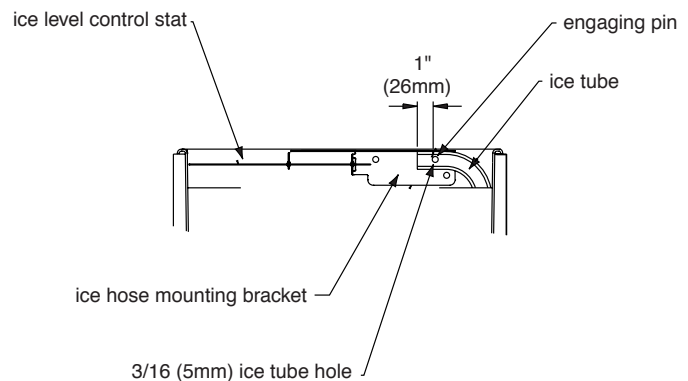
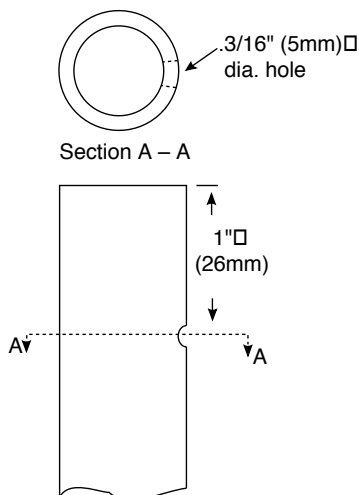
9. Slip supplied hose clamp onto tube and push tube onto exit port of evaporator.



**Only use tubing supplied by Follett Corporation.**

**Do not twist hose when securing to evaporator.**

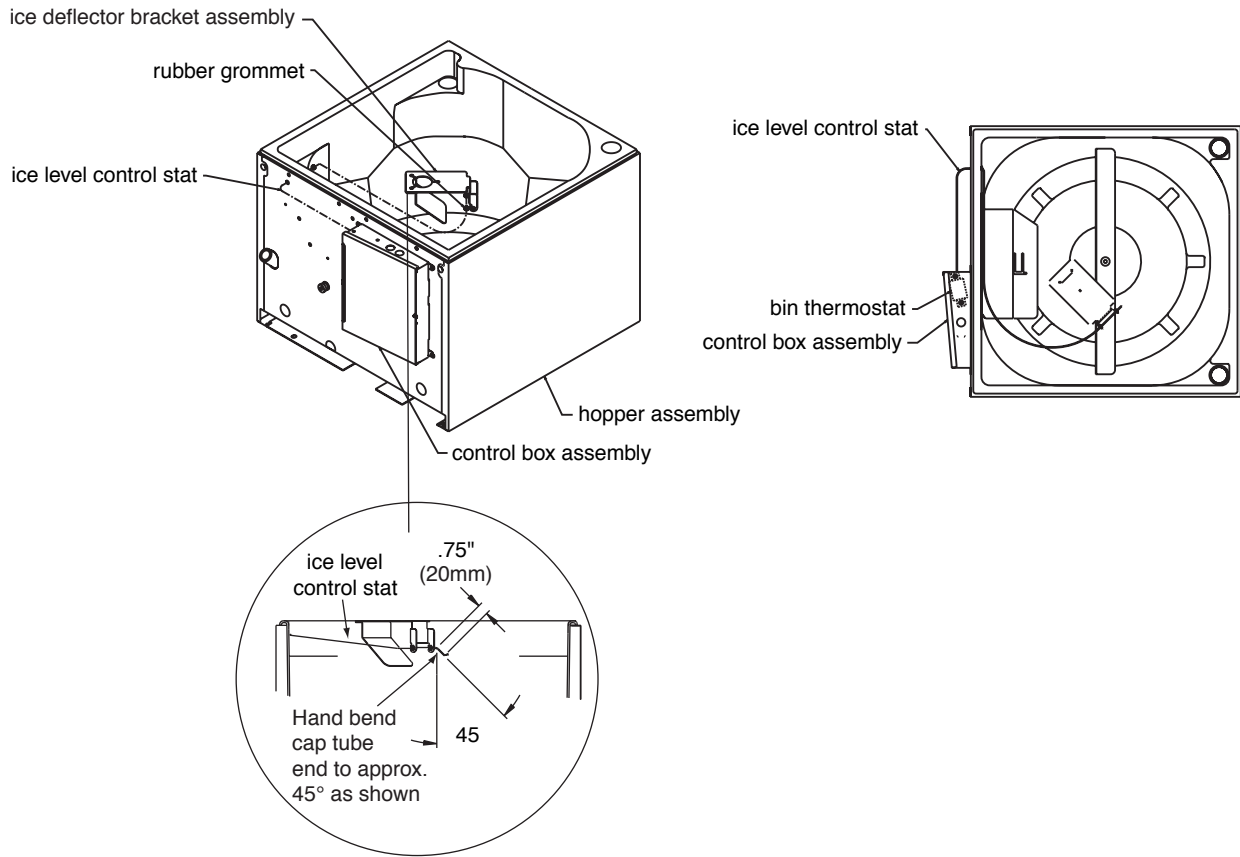
10. Fasten tube on port with hose clamp, being sure that clamp is positioned on evaporator side of nozzle flange.
11. Tighten clamp.



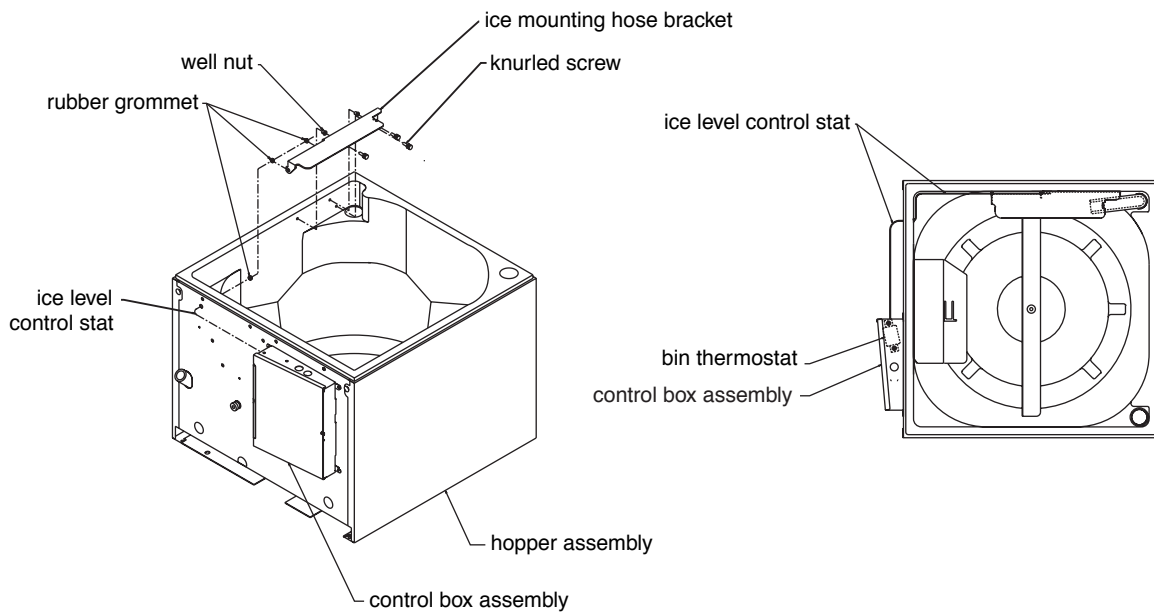


# Thermostat locations

## Thermostat locations – 25CT400A/W, 25HT400A/W, 50CT400A/W, 50HT400A/W

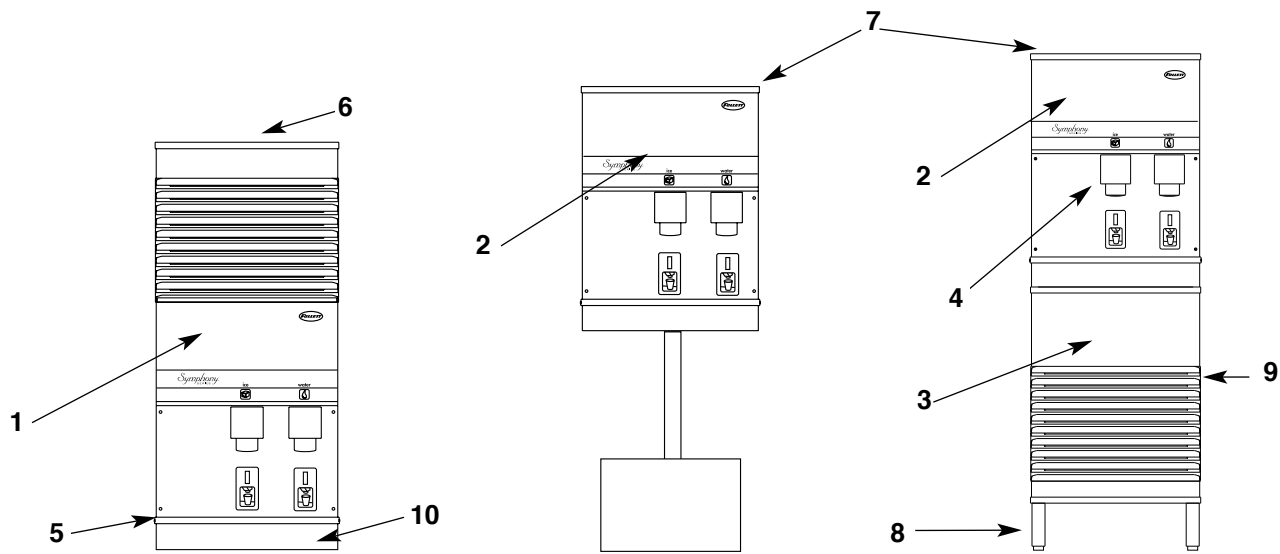


## Thermostat locations – 25CR400A/W, 50CR400A/W, 25HR400A/W, 25FB400A/W, 50HR400A/W, 50FB400A/W



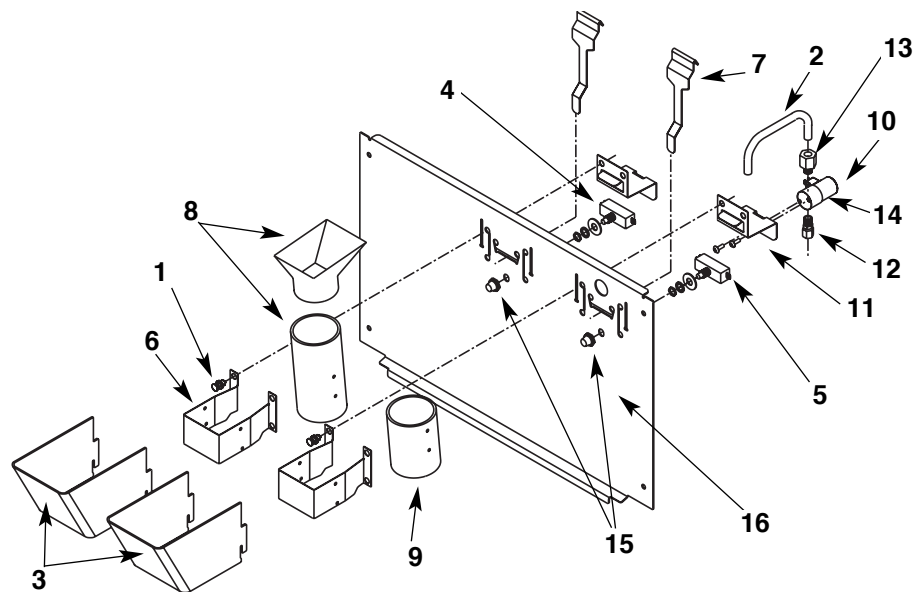
# Parts

## Dispenser exterior



Part #	Description	Reference
502679	Cover, top front, 25 countertop (CT) & wall mount (HT) units	1
502680	Cover, top front, 50 countertop (CT) & wall mount (HT) units	1
502677	Cover, top front, 25 countertop units with Satellite-fill icemaker (CR), wall mount (HR) units & freestanding (FB)	2
502678	Cover, top front, 50 countertop units with Satellite-fill icemaker (CR), wall mount (HR) units & freestanding (FB)	2
502694	Cover, lower section, stainless, 25/50 freestanding (FB) units	3
502681	Cover, dispense chute	4
501100	Knurled screws, front cover	Not shown
502682	Drain pan	5
502683	Grille, drain pan	Not shown
502688	Lid, icemaker, 25/50, countertop (CT) and wall mount (HT) units	6
502684	Lid, 25/50, countertop (CR), wall mount units with Satellite-fill icemakers (HR) & freestanding (FB) units	7
502699	Rear panel, base stand, perforated	Not shown
502088	Leg kit, 6" (153mm), adjustable, for freestanding units – set of 4	Not shown
502298	Single leg, for freestanding units	8
00112854	Adapter, drain line	Not shown
502700	Base stand assembly, countertop dispenser	9
502778	Drain pan and base assembly (includes 502682 and 502683)	10
502701	Drain fitting, brass, icemaker, freestanding units	Not shown
00109728	Drain fitting, plastic, icemaker, freestanding units (includes screws)	Not shown
502776	Cord, power, dispenser	Not shown
502777	Cord and plug, female, bin signal, Satellite-fill IM	Not shown
502359	Clean switch, SensorSAFE	Not shown
502816	Cord and plug, female, bin signal, top mount	Not shown
502817	Cord and plug, female, bin signal, freestanding dispensers	Not shown
502788	Cord & plug, female, icemaker power, top mount	Not shown
502786	Cord & plug, female, icemaker power, freestanding	Not shown
502805	Caster	Not shown

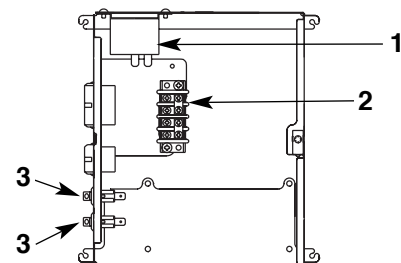
## Dispense chute and splash panel areas — lever models



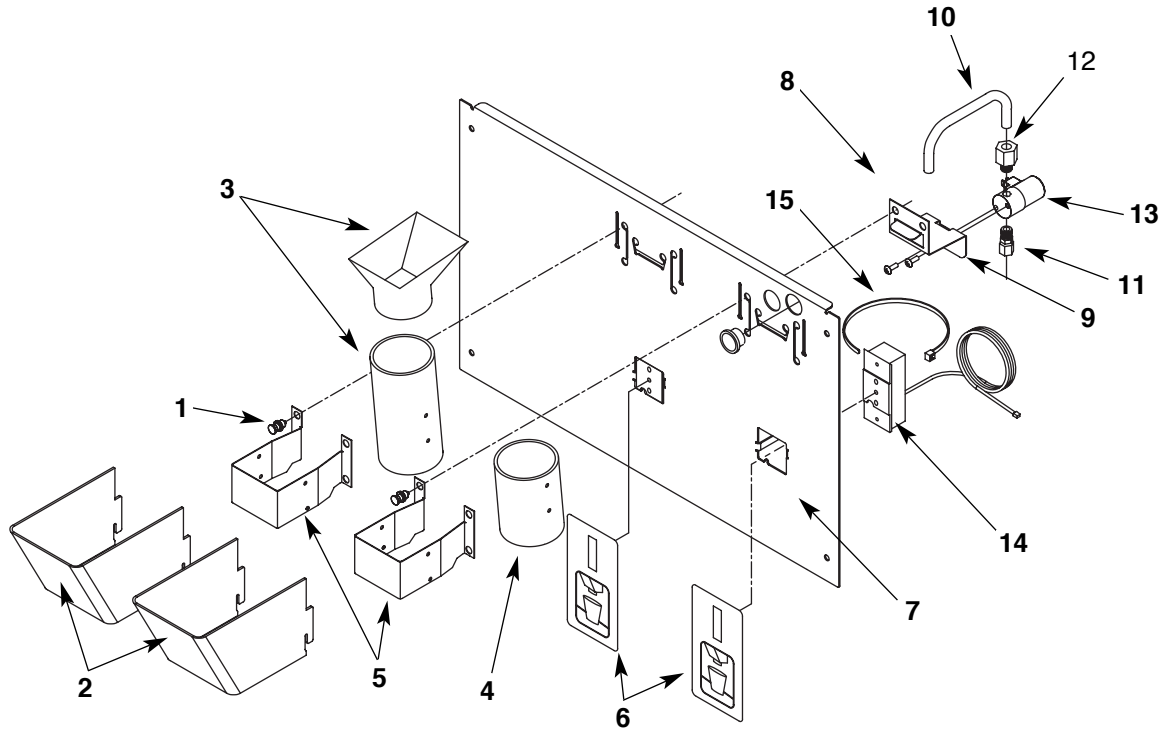
Part #	Description	Reference
502057	Fastener, dispense chute bracket	1
502356	Tube, water station	2
502681	Cover, dispense chute	3
502359	Switch, dispense, ice, lever actuated (includes 501841)	4
502359	Switch, dispense, water, lever actuated (includes 501841)	5
502247	Bracket, chute (includes fasteners 502057)	6
502358	Lever, dispense	7
502689	Chute and funnel, ice	8
502249	Chute, water	9
502357	Solenoid assembly, water (includes 502243, 502356, 502246, 502355 and 502262) 120V, 60Hz	10
502355	Bracket, water solenoid and lever	11
502246	Fitting, inlet, 1/8" MPT x 1/4" comp	12
502262	Fitting, outlet, 1/8" MPT x 3/8" comp	13
502243	Solenoid valve, water, 120 V, 60Hz	14
501841	Boot, dispense switch button (mounts on 501829 switch)	15
502079	Tubing, water station, thermoplastic, 1/4" OD (sold by the foot)	Not shown
502787	Splash panel, lever dispense	16

## Electrical box (front view) — lever models

Part #	Description	Reference
500514	Thermostat	1
501604	Terminal block	2
502209	Switch, dispenser power	3
502209	Switch, icemaker bin signal	3



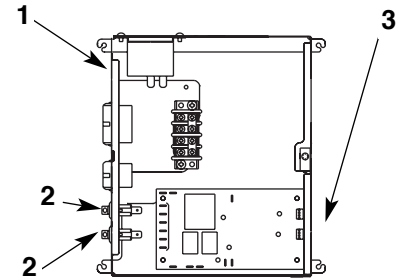
## Dispense chute and splash panel areas — SensorSAFE models



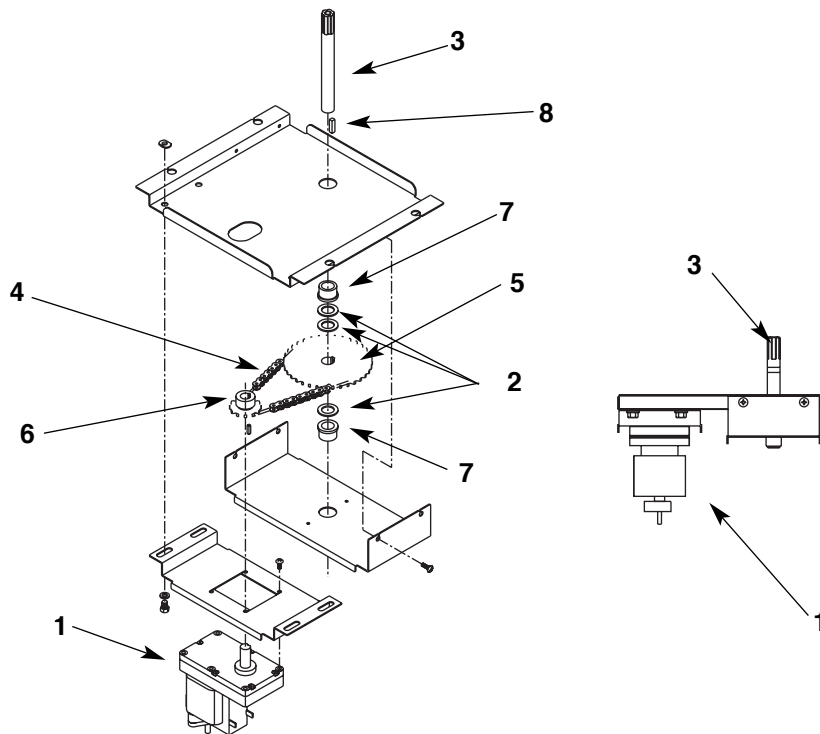
Part #	Description	Reference
502057	Fastener, dispense chute bracket	1
502681	Cover, dispense chute (includes labels)	2
502689	Chute and funnel, ice	3
502249	Chute, water	4
00129908	Chute and funnel, ice, wall mount, no drain pan	Not shown
00129155	Chute, water, wall hung, no drain pan	Not shown
502247	Bracket, chute (includes fasteners 502057)	5
502690	Lens, sensor	6
502695	Splash panel, units with drain pan (includes 2 of 502690)	7
502715	Splash panel, wall mount units w/o drain pan	Not shown
502357	Solenoid assembly, water, 120V, 60Hz (includes. 502243, 502356, 502246, 502355, 502262)	8
502355	Bracket, water solenoid and lever	9
502356	Tube, water station	10
502246	Fitting, inlet, 1/8" MPT x 1/4" comp	11
502262	Fitting, outlet, 1/8" MPT x 3/8" comp	12
502243	Solenoid valve, water, 120V, 60Hz	13
00122978	Sensor (includes 502690 and 203611)	14
203611	Ty-rap, sensor mounting	15

## Electrical box (front view) – SensorSAFE models

Part #	Description	Reference
500514	Thermostat, bin level	1
502209	Switch, dispenser power	2
502209	Switch, icemaker bin signal	2
502242	Control board, SensorSAFE	3
502359	Clean switch, SensorSAFE	Not shown
501841	Boot, clean switch	Not shown



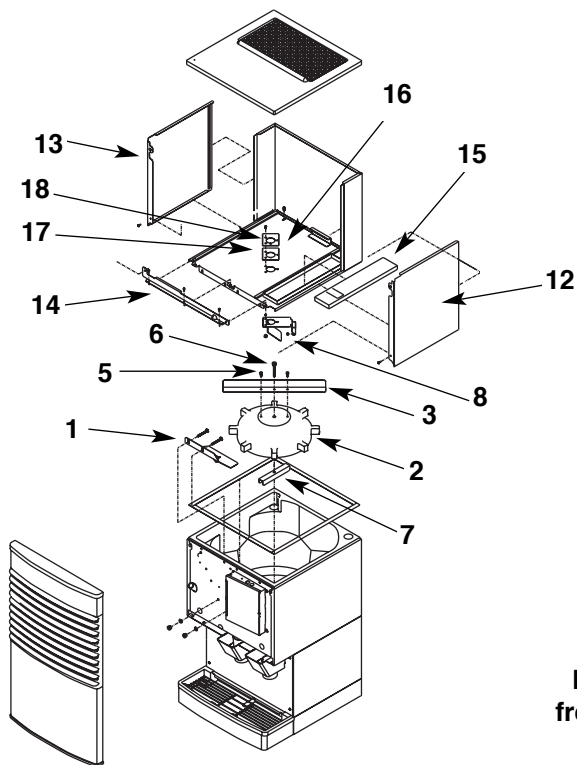
## Wheel motor and drive system



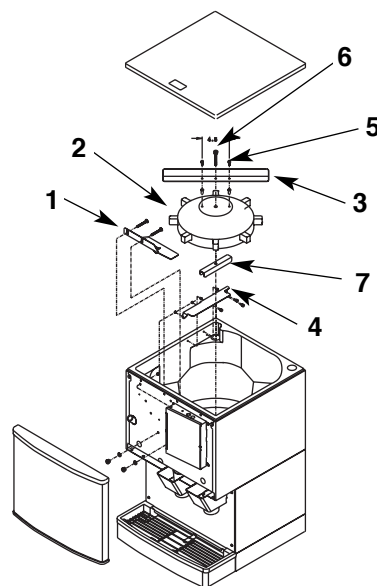
Part #	Description	Reference
501861	Wheel motor, 120V, 60Hz	1
501026	Washer, thrust	2
501607	Fan blade, wheel motor	Not shown
501619	Drive shaft (includes threaded rod and nut)	3
502691	Chain, pitch 54, link	4
502692	Sprocket, drive shaft, 35T	5
501019	Sprocket, wheel motor, 10T	6
501024	Bearing, drive shaft	7
500799	Connecting link, chain	Not shown
500637	Key, drive shaft	8
502020	Dispenser drive assembly	Parts 1-8 above

# Hopper components

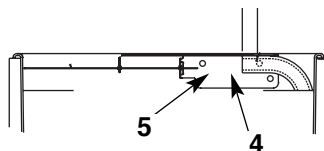
Top view – all top mounted units



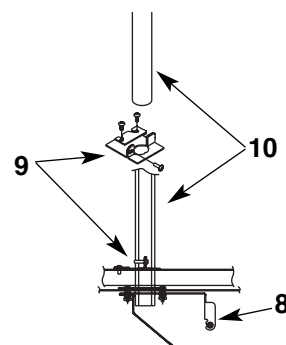
Top view – freestanding and Satellite-fill units



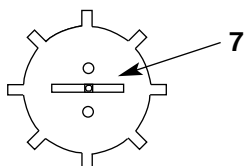
Ice tube bracket – side view – freestanding & Satellite-fill units



Ice tube bracket – side view – all top mounted units



Dispense wheel – bottom view all units

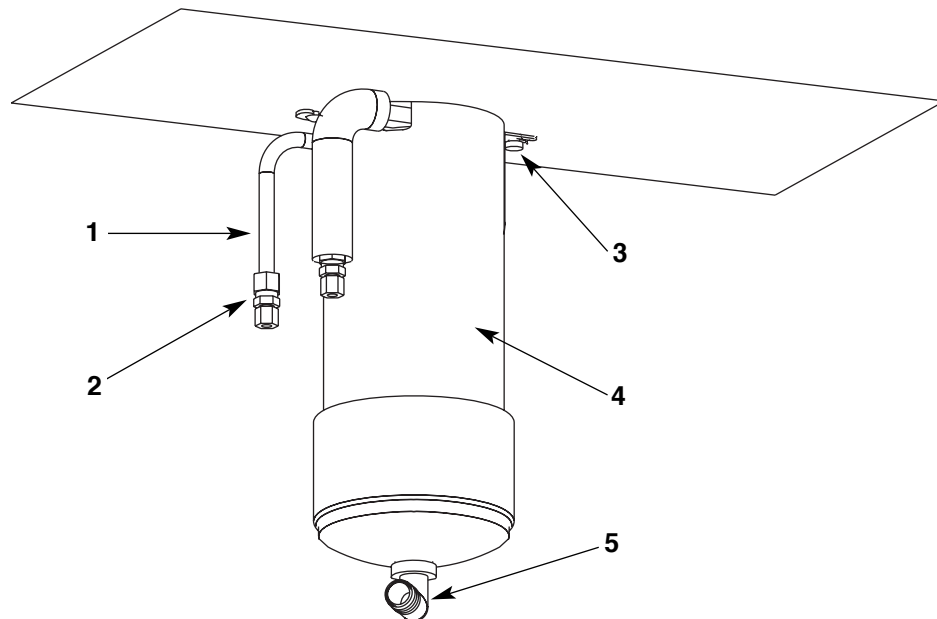


Part #	Description	Reference
501608	Baffle, ice	1
501614	Wheel, dispense (includes drive bar, rotating agitator, threaded bar & rod)	2
502821	Wheel, dispense (wheel only)	2
501609	Agitator, rotating	3
502712	Bracket, ice tube	4
501100	Screw	5
501612	Rod, threaded (includes knurled nut)	6
501617	Drive bar assembly (includes threaded rod and nut)	7
501616	Ice deflector/cap tube bracket (units with top mounted icemaker)	8
502698	Bracket, ice tube entry (units with top mounted icemaker)	9
502697	Ice transport tube assembly (units with top mounted icemakers)	10
501613	Screws, knurled	11
502721	Side panel, RH	12
502720	Side panel, LH	13
502713	Bracket, icemaker hold-down	14
501917	Cover, hopper access	15
502693	Cover, hopper	16
502824	Gasket, ice entry	17
00120279	Kit, ice tube entry, top mount (includes 502824)	18

## Ice transport tubing

Part #	Description	Reference
502522	Ice transport tube (Satellite-fill units) - 10 ft	Not shown
502523	Ice transport tube (Satellite-fill units) - 20 ft	Not shown
501176	Ice transport tube insulation (Satellite-fill units only) - sold by the foot	Not shown
502328	Ice transport tube assembly (50 freestanding (FB) units)	Not shown
502329	Ice transport tube assembly (25 freestanding (FB) units)	Not shown
502697	Ice transport tube assembly (top mount units)	Not shown

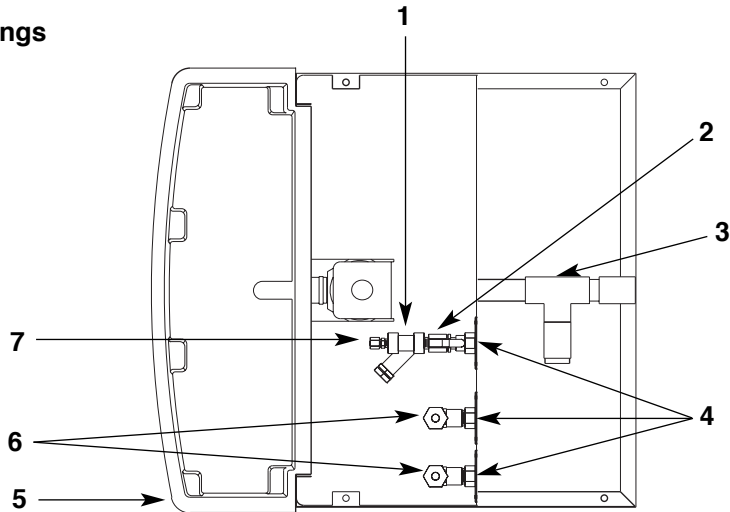
## Chilled water components



Part #	Description	Reference
502598	Coil, chilled water (includes two 502599)	1
502599	Fitting, water coil	2
502600	Brackets, chilled water canister, pair (includes screws)	3
502601	Canister, chilled water (includes 502600 and 502605)	4
502605	Elbow, drain	5
502602	Assembly, chilled water	Parts 1-5 above
502604	Tee, drain line	Not shown

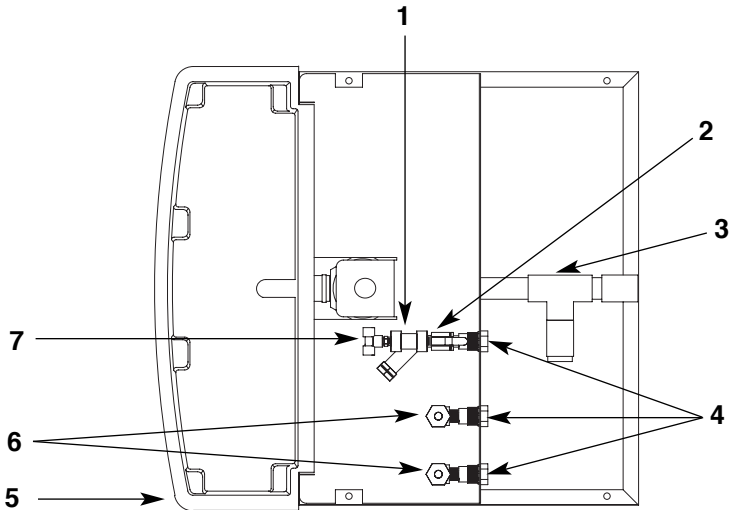
# Countertop dispenser plumbing connections

## Mounting plate fittings



Part #	Description	Reference
00136663	Strainer	1
502222	Valve, water shut-off	2
502685	Drain tube assembly	3
502100	Fitting, water inlet with mounting plate	4
502682	Drain pan	5
502718	Elbow	6
502433	Tee, water inlet	7

## Bulkhead fittings



Part #	Description	Reference
00136663	Strainer	1
502222	Valve, water shut-off	2
502685	Drain tube assembly	3
00151134	Fitting, water inlet	4
502682	Drain pan	5
00149674	Elbow	6
502433	Tee, water inlet	7